



**MULTI-INNO TECHNOLOGY CO., LTD.**

## **OLED MODULE SPECIFICATION**

**Model : MI12864RO-Y**

Revision	1.0
Engineering	
Date	
Our Reference	

Address : Room 10J,Xin HaoFang Building, No.188 Shennan Road,  
Nanshan Drstrict, ShenZhen,China.

Tel : (86-755)2643 9937

Fax : (86-755)8613 4241

Email : [sales@multi-inno.com](mailto:sales@multi-inno.com)

Web : <http://www.multi-inno.com>



# **PRODUCT CONTENTS**

- n PHYSICAL DATA**
- n ABSOLUTE MAXIMUM RATINGS**
- n EXTERNAL DIMENSIONS**
- n ELECTRICAL CHARACTERISTICS**
- n TIMING OF POWER SUPPLY**
- n ELECTRO-OPTICAL CHARACTERISTICS**
- n INTERFACE PIN CONNECTIONS**
- n COMMAND TABLE**
- n INITIALIZATION CODE**
- n SCHEMATIC EXAMPLE**
- n RELIABILITY TESTS**
- n OUTGOING QUALITY CONTROL SPECIFICATION**
- n CAUTIONS IN USING OLED MODULE**



## n PHYSICAL DATA

No.	Items:	Specification:	Unit
1	Diagonal Size	1.02	Inch
2	Resolution	128(H) x 64(V)	Dots
3	Active Area	23.02(W) x 11.82(H)	mm
4	Outline Dimension (Panel)	30.00(W) x 20.16(H)	mm
5	Pixel Pitch	0.180(W) x 0.225(H)	mm
6	Pixel Size	0.150(W) x 0.195(H)	mm
7	Driver IC	SSD1308Z	-
8	Display Color	Yellow	-
9	Gray Scale	1	Bit
10	Interface	SPI/Parallel/ IIC	-
11	IC package type	COG	-
12	Thickness	1.5±0.1	mm
13	Weight	TBD	g
14	Duty	1/64	-

## n ABSOLUTE MAXIMUM RATINGS

Unless otherwise specified,  $V_{SS} = 0V$

(  $T_a = 25^{\circ}C$  )

Items		Symbol	Min	Typ.	Max	Unit
Supply Voltage	Logic	$V_{DD}$	-0.3	-	4	V
	Driving	$V_{pp}$	0	-	16.0	V
Operating Temperature		$T_{op}$	-20	-	70	$^{\circ}C$
Storage Temperature		$T_{st}$	-30	-	80	$^{\circ}C$
Humidity		-	-	-	90	%RH

### NOTE:

Permanent device damage may occur if **ABSOLUTE MAXIMUM RATINGS** are exceeded. **Functional operation should be restricted to the conditions as detailed in the operational sections of this data sheet. Exposure to absolute maximum rating conditions for extended periods may affect reliability.**



**n ELECTRICAL CHARACTERISTICS****◆DC Characteristics**Unless otherwise specified,  $V_{SS} = 0V$ ,  $V_{DD} = 1.65V$  to  $3.3V$  (  $T_a = 25^\circ C$  )

Items		Symbol	Min	Typ.	Max	Unit
Supply Voltage	Logic	$V_{DD}$	1.65	3.0	3.3	V
	Operating	$V_{PP}$	7.0	12.0	15.0	V
Input Voltage	High Voltage	$V_{IH}$	$0.8 \times V_{DD}$	-	-	V
	Low Voltage	$V_{IL}$	-	-	$0.2 \times V_{DD}$	V
Output Voltage	High Voltage	$V_{OH}$	$0.9 \times V_{DD}$	-	-	V
	Low Voltage	$V_{OL}$	-	-	$0.1 \times V_{DD}$	V

## ◆ AC Characteristics

### 4-wire SPI Serial Interface Timing Characteristics

(VDD - VSS = 1.65V to 3.3V, TA = 25°C)

Symbol	Parameter	Min	Typ	Max	Unit
$t_{\text{cycle}}$	Clock Cycle Time	100	-	-	ns
$t_{\text{AS}}$	Address Setup Time	15	-	-	ns
$t_{\text{AH}}$	Address Hold Time	15	-	-	ns
$t_{\text{CSS}}$	Chip Select Setup Time	20	-	-	ns
$t_{\text{CSH}}$	Chip Select Hold Time	10	-	-	ns
$t_{\text{DSW}}$	Write Data Setup Time	15	-	-	ns
$t_{\text{DHW}}$	Write Data Hold Time	15	-	-	ns
$t_{\text{CLKL}}$	Clock Low Time	20	-	-	ns
$t_{\text{CLKH}}$	Clock High Time	20	-	-	ns
$t_{\text{R}}$	Rise Time	-	-	40	ns
$t_{\text{F}}$	Fall Time	-	-	40	ns

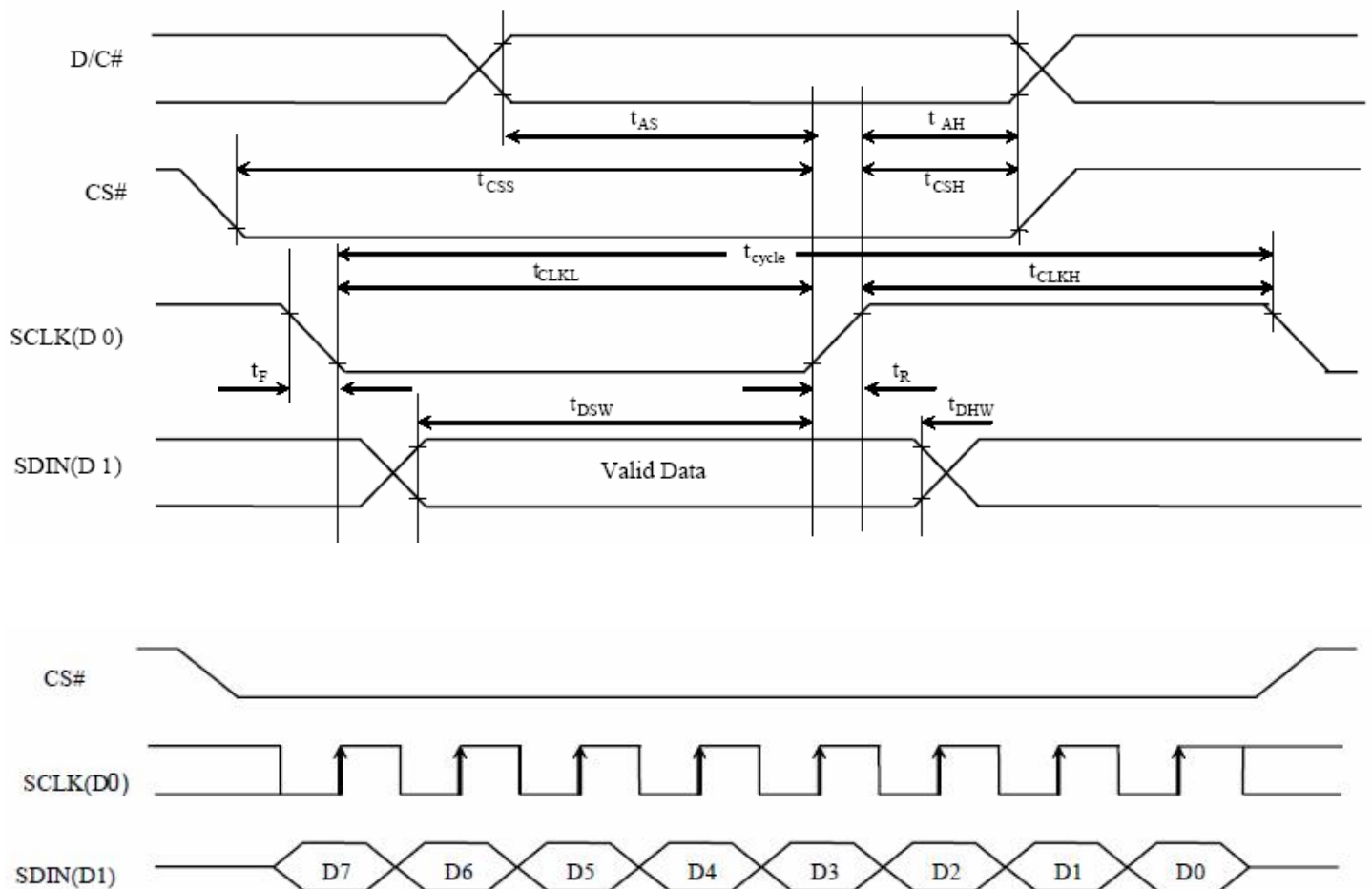

**8080-Series MCU Parallele Interface Timing Characteristics**

VDD - VSS = 1.65V to 3.3V, TA = 25°C)

Symbol	Parameter	Min	Typ	Max	Unit
$t_{\text{cycle}}$	Clock Cycle Time	300	-	-	ns
$t_{\text{AS}}$	Address Setup Time	10	-	-	ns
$t_{\text{AH}}$	Address Hold Time	0	-	-	ns
$t_{\text{DSW}}$	Write Data Setup Time	40	-	-	ns
$t_{\text{DHW}}$	Write Data Hold Time	7	-	-	ns
$t_{\text{DHR}}$	Read Data Hold Time	20	-	-	ns
$t_{\text{OH}}$	Output Disable Time	-	-	70	ns
$t_{\text{ACC}}$	Access Time	-	-	140	ns
$t_{\text{PWLR}}$	Read Low Time	120	-	-	ns
$t_{\text{PWLW}}$	Write Low Time	60	-	-	ns
$t_{\text{PWHR}}$	Read High Time	60	-	-	ns
$t_{\text{PWHW}}$	Write High Time	60	-	-	ns
$t_{\text{R}}$	Rise Time	-	-	40	ns
$t_{\text{F}}$	Fall Time	-	-	40	ns
$t_{\text{CS}}$	Chip select setup time	0	-	-	ns
$t_{\text{CSH}}$	Chip select hold time to read signal	0	-	-	ns
$t_{\text{CSF}}$	Chip select hold time	20	-	-	ns

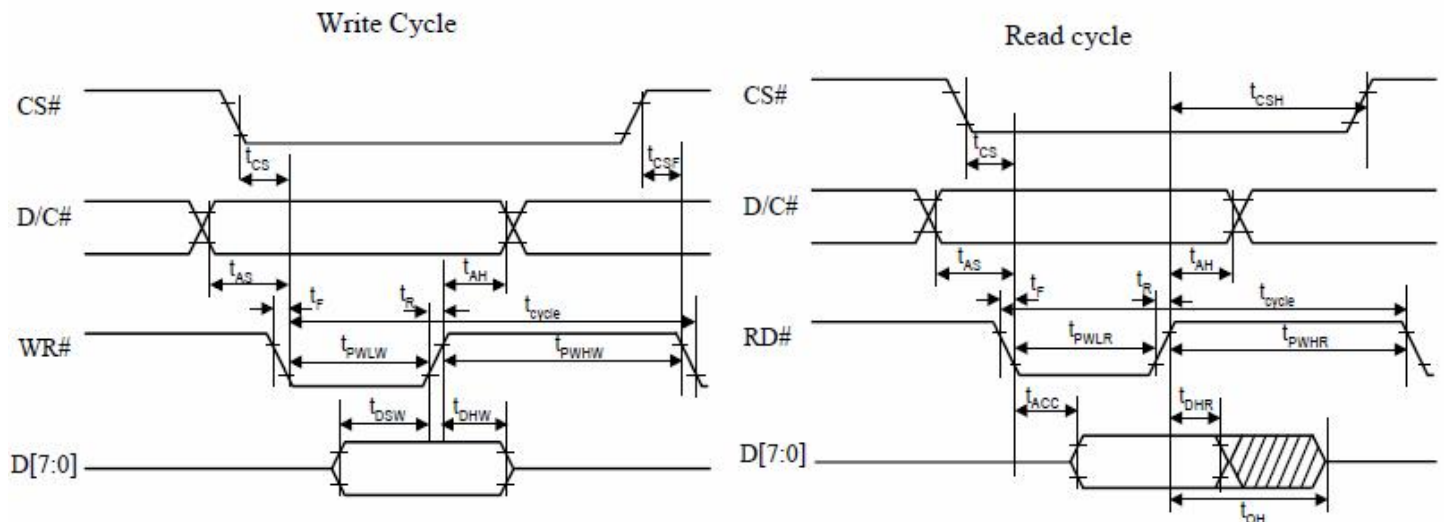

## I2C Interface Timing Characteristics

(VDD - VSS = 1.65V to 3.3V, TA = 25°C)

Symbol	Parameter	Min	Typ	Max	Unit
$t_{\text{cycle}}$	Clock Cycle Time	2.5	-	-	us
$t_{\text{HSTART}}$	Address Setup Time	0.6	-	-	us
$t_{\text{HD}}$	Data Hold Time (for “SDAOUT” pin)	0	-	-	ns
	Data Hold Time (for “SDAIN” pin)	300	-	-	ns
$t_{\text{SD}}$	Data Setup Time	100	-	-	ns
$t_{\text{SSTART}}$	Start condition Setup Time (Only relevant for a repeated Start condition)	0.6	-	-	us
$t_{\text{SSTOP}}$	Stop condition Setup Time	0.6	-	-	us
$t_{\text{R}}$	Rise Time for data and clock pin	-	-	300	ns
$t_{\text{F}}$	Fall Time for data and clock pin	-	-	300	ns
$t_{\text{IDLE}}$	Idle Time before a new transmission can start	1.3			us

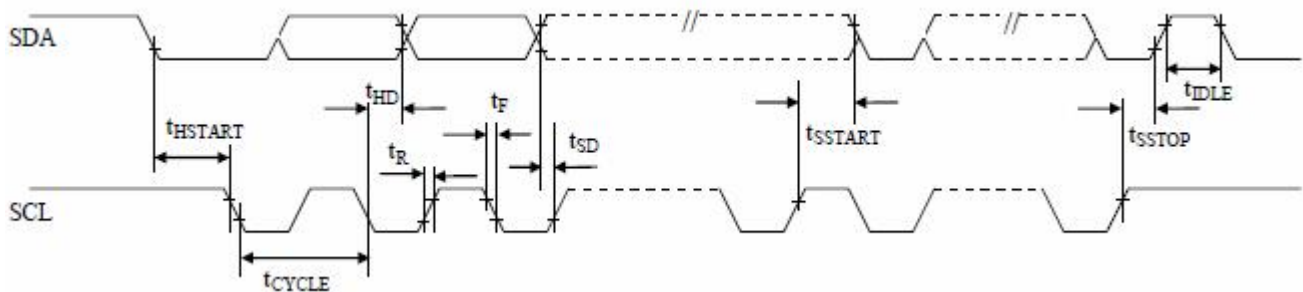

## n TIMING OF POWER SUPPLY

### ◆ Power ON sequence:

1. Power ON VDD
2. After VDD become stable, set RES pin LOW (logic low) for at least 3us ( $t_1$ )<sup>(4)</sup> and then HIGH (logic high).
3. After set RES pin LOW (logic low), wait for at least 3us ( $t_2$ ). Then Power ON V<sub>PP</sub>.<sup>(1)</sup>
4. After V<sub>PP</sub> become stable, send command AFh for display ON. SEG/COM will be ON after 100ms( $t_{AF}$ ).

#### Power on sequence

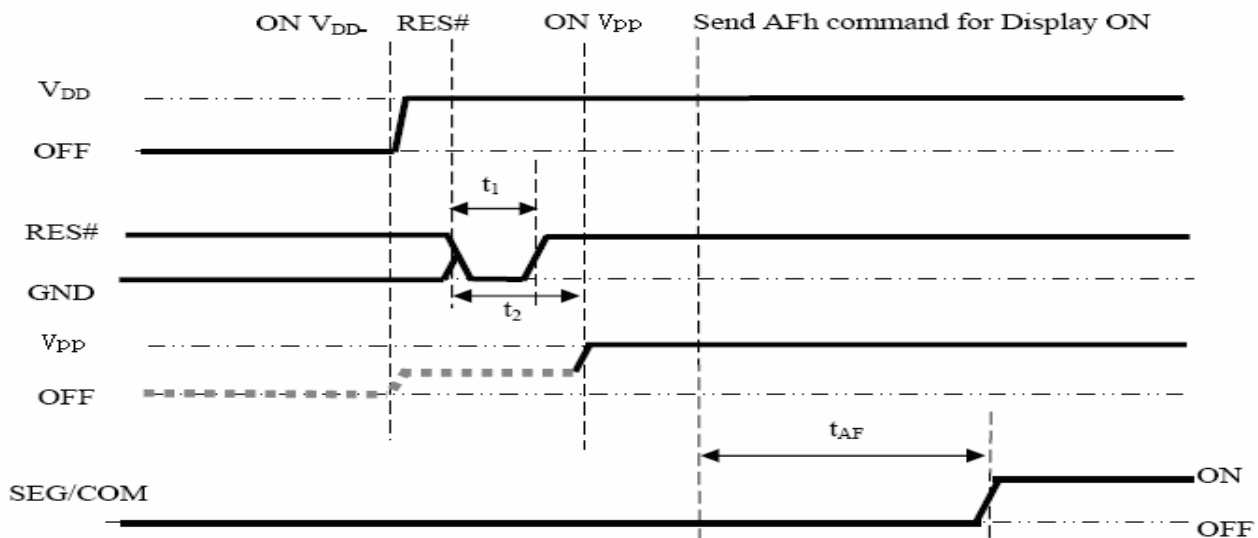

### ◆ Power OFF sequence:

1. Send command AEh for display OFF.
2. Power OFF V<sub>PP</sub>.<sup>(1), (2), (3)</sup>
3. Power OFF VDD after  $t_{OFF}$ .<sup>(5)</sup> (Typical  $t_{OFF}$ =100ms)

#### Power off sequence

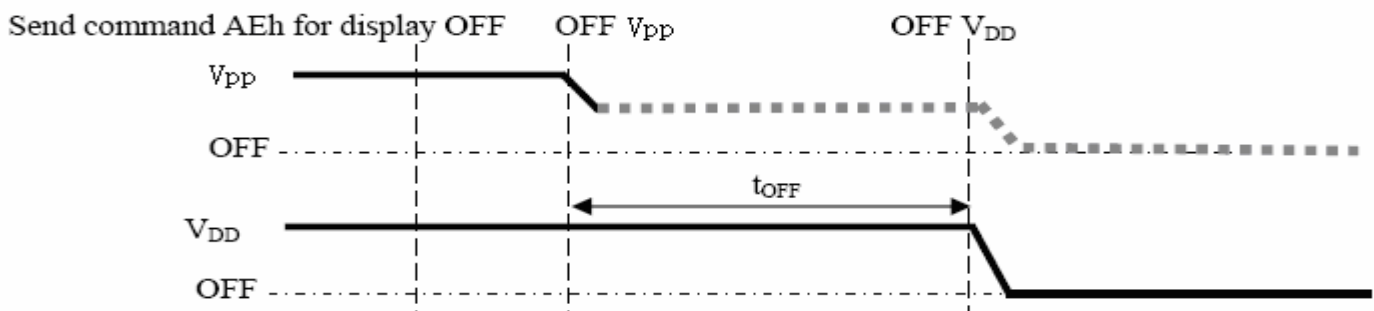

### Note:

- (1) Since an ESD protection circuit is connected between V<sub>DD</sub> and V<sub>PP</sub>, V<sub>PP</sub> becomes lower than V<sub>DD</sub> whenever V<sub>DD</sub> is ON and V<sub>PP</sub> is OFF as shown in the dotted line of V<sub>PP</sub> in Figures above.
- (2) V<sub>PP</sub> should be kept float (i.e. disable) when it is OFF.
- (3) Power Pins (V<sub>DD</sub>, V<sub>PP</sub>) can never be pulled to ground under any circumstance.
- (4) The register values are reset after  $t_1$ .
- (5) V<sub>DD</sub> should not be Power OFF before V<sub>PP</sub> Power OFF.

**n ELECTRO-OPTICAL CHARACTERISTICS (Ta=25°C)**

Items		Symbol	Min.	Typ.	Max.	Unit	Remark
Operating Luminance		L	70	85	-	cd /m <sup>2</sup>	Yellow
Power Consumption		P	-	35	45	mW	30% pixels ON L=85cd/m <sup>2</sup>
Frame Frequency		Fr	-	100	-	Hz	
Color Coordinate	Yellow	CIE x	0.45	0.48	0.51	CIE1931	Darkroom
		CIE y	0.47	0.50	0.53		
Response Time	Rise	Tr	-	-	0.02	ms	-
	Decay	Td	-	-	0.02	ms	-
Contrast Ratio		Cr	10000:1	-	-		Darkroom
Viewing Angle Uniformity		$\Delta \theta$	160	-	-	Degree	-
Operating Life Time		Top	50,000	-	-	Hours	L=85cd/m <sup>2</sup>

**Note:**

1. 85cd/m<sup>2</sup> is based on V<sub>DD</sub>=3.0V, V<sub>PP</sub>=12.0V, contrast command setting 0xBF;

2. Contrast ratio is defined as follows:

$$\text{Contrast ratio} = \frac{\text{Photo - detector output with OLED being "white"}}{\text{Photo - detector output with OLED being "black"}}$$

3. **Life Time** is defined when the Luminance has decayed to less than 50% of the initial Luminance specification. (Odd and even chess board alternately displayed) ,(The initial value should be closed to the typical value after adjusting.).

## n INTERFACE PIN CONNECTIONS

NO.	Symbol	Description
1	VPP	Power supply for panel driving voltage, this is also the most positive power supply pin.
2	VCOMH	COM signal deselect voltage level. A capacitor should be connected between this pin and $V_{SS}$ .
3	IREF	This is segment output current reference pin. When external $I_{REF}$ is used, a resistor should be connected between this pin and $V_{SS}$ to maintain the $I_{REF}$ current at 19 $\mu$ A.
4	D7	Bi-directional data bus to be connected to the MCU 's data bus. When serial interface is selected, this pin should be pulled LOW (i.e. connect to $V_{SS}$ ).
5	D6	Bi-directional data bus to be connected to the MCU 's data bus. When serial interface is selected, this pin should be pulled LOW (i.e. connect to $V_{SS}$ ).
6	D5	Bi-directional data bus to be connected to the MCU 's data bus. When serial interface is selected, this pin should be pulled LOW (i.e. connect to $V_{SS}$ ).
7	D4	Bi-directional data bus to be connected to the MCU 's data bus. When serial interface is selected, this pin should be pulled LOW (i.e. connect to $V_{SS}$ ).
8	D3	Bi-directional data bus to be connected to the MCU 's data bus. When serial interface is selected, this pin should be pulled LOW (i.e. connect to $V_{SS}$ ).
9	D2	Bi-directional data bus to be connected to the MCU 's data bus. When serial interface is selected, this pin should be left open.
10	D1	Bi-directional data bus to be connected to the MCU 's data bus. When serial interface is selected, this pin will be the serial data input.
11	D0	Bi-directional data bus to be connected to the MCU 's data bus. When serial interface is selected, this pin will be the serial clock input.
12	RDB	This is Read /Write control pin connected to MCU interface. When serial interface is selected, this pin must be pulled LOW (i.e. connect to $V_{SS}$ ).
13	WRB	This is Read /Write control pin connected to MCU interface. When serial interface is selected, this pin must be pulled LOW (i.e. connect to $V_{SS}$ ).
14	A0	Data/Command control pin. When this pin is pulled HIGH (i.e. connect to $V_{DD}$ ), the data at D 7:0 is treated as data. When it is pulled low, the data at D 7:0 will be transferred to the command register.
15	RESB	Reset signal input. When this pin is pulled low, initialization of the chip is executed. Keep this pin HIGH (i.e. connect to $V_{DD}$ ) during normal operation.
16	CSB	Chip selection input (Active low).
17	P/S	MCU bus interface selection pin. In order to select 4-wire SPI interface, this pin should be pulled LOW (i.e. connect to $V_{SS}$ ).
18	C86	MCU bus interface selection pin. In order to select 4-wire SPI interface, this pin should be pulled LOW (i.e. connect to $V_{SS}$ ).
19	VDD	Power supply for core logic operation.
20	NC	No connection.
21	NC	No connection.



22	NC	No connection.
23	NC	No connection.
24	VSS	Ground pin.

**MCU Bus Interface Pin Selection**

Pin Name	I <sup>2</sup> C Interface	6800-parallel interface (8 bit)	8080-parallel interface (8 bit)	4-wire Serial interface
C86	1	0	1	0
P/S	0	1	1	0

**Note**

<sup>(1)</sup> 0 is connected to V<sub>SS</sub>

<sup>(2)</sup> 1 is connected to V<sub>DD</sub>

## n COMMAND TABLE

I. Fundamental Command Table											
D/C#	Hex	D7	D6	D5	D4	D3	D2	D1	D0	Command	Description
0	00~0F	0	0	0	0	X <sub>3</sub>	X <sub>2</sub>	X <sub>1</sub>	X <sub>0</sub>	Set Lower Column Start Address for Page Addressing Mode	Set the lower nibble of the column start address register for Page Addressing Mode using X[3:0] as data bits. The initial display line register is reset to 0000b after RESET.  <b>Note</b> (1) This command is only for page addressing mode
0	10~1F	0	0	0	1	X <sub>3</sub>	X <sub>2</sub>	X <sub>1</sub>	X <sub>0</sub>	Set Higher Column Start Address for Page Addressing Mode	Set the higher nibble of the column start address register for Page Addressing Mode using X[3:0] as data bits. The initial display line register is reset to 0000b after RESET.  <b>Note</b> (1) This command is only for page addressing mode
0 0	20 A[1:0]	0 *	0 *	1 *	0 *	0 *	0 *	0 A <sub>1</sub>	0 A <sub>0</sub>	Set Memory Addressing Mode	A[1:0] = 00b, Horizontal Addressing Mode A[1:0] = 01b, Vertical Addressing Mode A[1:0] = 10b, Page Addressing Mode (RESET) A[1:0] = 11b, Invalid
0 0 0	21 A[6:0] B[6:0]	0 * *	0 A <sub>6</sub> B <sub>6</sub>	1 A <sub>5</sub> B <sub>5</sub>	0 A <sub>4</sub> B <sub>4</sub>	0 A <sub>3</sub> B <sub>3</sub>	0 A <sub>2</sub> B <sub>2</sub>	0 A <sub>1</sub> B <sub>1</sub>	1 A <sub>0</sub> B <sub>0</sub>	Set Column Address	Setup column start and end address A[6:0] : Column start address, range : 0-127d, (RESET=0d)  B[6:0] : Column end address, range : 0-127d, (RESET =127d)  <b>Note</b> (1) This command is only for horizontal or vertical addressing mode.
0 0 0	22 A[2:0] B[2:0]	0 * *	0 * *	1 * *	0 * *	0 * *	0 A <sub>2</sub> B <sub>2</sub>	1 A <sub>1</sub> B <sub>1</sub>	0 A <sub>0</sub> B <sub>0</sub>	Set Page Address	Setup page start and end address A[2:0] : Page start Address, range : 0-7d, (RESET = 0d) B[2:0] : Page end Address, range : 0-7d, (RESET = 7d)  <b>Note</b> (1) This command is only for horizontal or vertical addressing mode.
0	40~7F	0	1	X <sub>5</sub>	X <sub>4</sub>	X <sub>3</sub>	X <sub>2</sub>	X <sub>1</sub>	X <sub>0</sub>	Set Display Start Line	Set display RAM display start line register from 0-63 using X <sub>5</sub> X <sub>3</sub> X <sub>2</sub> X <sub>1</sub> X <sub>0</sub> . Display start line register is reset to 000000b during RESET.
0 0	81 A[7:0]	1 A <sub>7</sub>	0 A <sub>6</sub>	0 A <sub>5</sub>	0 A <sub>4</sub>	0 A <sub>3</sub>	0 A <sub>2</sub>	0 A <sub>1</sub>	1 A <sub>0</sub>	Set Contrast Control	Double byte command to select 1 out of 256 contrast steps. Contrast increases as the value increases. (RESET = 7Fh )



I. Fundamental Command Table											
D/C#	Hex	D7	D6	D5	D4	D3	D2	D1	D0	Command	Description
0	A0/A1	1	0	1	0	0	0	0	X <sub>0</sub>	Set Segment Re-map	A0h, X[0]=0b: column address 0 is mapped to SEG0 (RESET) A1h, X[0]=1b: column address 127 is mapped to SEG0
0	A4/A5	1	0	1	0	0	1	0	X <sub>0</sub>	Entire Display ON	A4h, X <sub>0</sub> =0b: Resume to RAM content display (RESET) Output follows RAM content A5h, X <sub>0</sub> =1b: Entire display ON Output ignores RAM content
0	A6/A7	1	0	1	0	0	1	1	X <sub>0</sub>	Set Normal/Inverse Display	A6h, X[0]=0b: Normal display (RESET) 0 in RAM: OFF in display panel 1 in RAM: ON in display panel A7h, X[0]=1b: Inverse display 0 in RAM: OFF in display panel 1 in RAM: OFF in display panel
0 0	A8 A[5:0]	1 *	0 *	1 A <sub>5</sub>	0 A <sub>4</sub>	1 A <sub>3</sub>	0 A <sub>2</sub>	0 A <sub>1</sub>	0 A <sub>0</sub>	Set Multiplex Ratio	Set MUX ratio to N+1 MUX N=A[5:0] : from 16MUX to 64MUX, RESET=111111b (i.e. 63d, 64MUX) A[5:0] from 0 to 14 are invalid entry.
0 0	AD A[4]	1 0	0 0	1 0	0 A <sub>4</sub>	1 0	1 0	0 0	1 0	External or internal I <sub>REF</sub> Selection	Select external or internal I <sub>REF</sub> : A[4] = '0' Select external I <sub>REF</sub> (RESET) A[4] = '1' Enable internal I <sub>REF</sub> during display ON  <b>Note</b> ( <sup>1</sup> ) Refer to section 8.8 for details.
0	AE AF	1	0	1	0	1	1	1	X <sub>0</sub>	Set Display ON/OFF	AEh, X[0]=0b: Display OFF (sleep mode) (RESET) AFh X[0]=1b: Display ON in normal mode
0	B0~B7	1	0	1	1	0	X <sub>2</sub>	X <sub>1</sub>	X <sub>0</sub>	Set Page Start Address for Page Addressing Mode	Set GDDRAM Page Start Address (PAGE0~PAGE7) for Page Addressing Mode using X[2:0].  <b>Note</b> ( <sup>1</sup> ) This command is only for page addressing mode
0	C0/C8	1	1	0	0	X <sub>3</sub>	0	0	0	Set COM Output Scan Direction	C0h, X[3]=0b: normal mode (RESET) Scan from COM0 to COM[N-1] C8h, X[3]=1b: remapped mode. Scan from COM[N-1] to COM0 Where N is the Multiplex ratio.
0 0	D3 A[5:0]	1 *	1 *	0 A <sub>5</sub>	1 A <sub>4</sub>	0 A <sub>3</sub>	0 A <sub>2</sub>	1 A <sub>1</sub>	1 A <sub>0</sub>	Set Display Offset	Set vertical shift by COM from 0d~63d The value is reset to 00h after RESET.
0 0	D5 A[7:0]	1 A <sub>7</sub>	1 A <sub>6</sub>	0 A <sub>5</sub>	1 A <sub>4</sub>	0 A <sub>3</sub>	1 A <sub>2</sub>	0 A <sub>1</sub>	1 A <sub>0</sub>	Set Display Clock Divide Ratio/Oscillator Frequency	A[3:0] : Define the divide ratio (D) of the display clocks (DCLK): Divide ratio= A[3:0] + 1, RESET is 0000b (divide ratio = 1)  A[7:4] : Set the Oscillator Frequency, F <sub>OSC</sub> . Oscillator Frequency increases with the value of A[7:4] and vice versa. RESET is 1000b Range:0000b~1111b Frequency increases as setting value increases.

**1. Fundamental Command Table**

D/C#	Hex	D7	D6	D5	D4	D3	D2	D1	D0	Command	Description												
00	D9 A[7:0]	1 A <sub>7</sub>	1 A <sub>6</sub>	0 A <sub>5</sub>	1 A <sub>4</sub>	1 A <sub>3</sub>	0 A <sub>2</sub>	0 A <sub>1</sub>	1 A <sub>0</sub>	Set Pre-charge Period	A[3:0] : Phase 1 period of up to 15 DCLK clocks 0 is invalid entry (RESET=2h)  A[7:4] : Phase 2 period of up to 15 DCLK clocks 0 is invalid entry (RESET=2h)												
00	DA A[5:4]	1 0	1 0	0 A <sub>5</sub>	1 A <sub>4</sub>	1 0	0 0	1 1	0 0	Set COM Pins Hardware Configuration	A[4]=0b, Sequential COM pin configuration A[4]=1b(RESET), Alternative COM pin configuration  A[5]=0b(RESET), Disable COM Left/Right remap A[5]=1b, Enable COM Left/Right remap												
00	DB A[6:4]	1 0	1 A <sub>6</sub>	0 A <sub>5</sub>	1 A <sub>4</sub>	1 0	0 0	1 0	1 0	Set V <sub>COMH</sub> Deselect Level	<table border="1"> <thead> <tr> <th>A[6:4]</th> <th>Hex code</th> <th>V<sub>COMH</sub> deselect level</th> </tr> </thead> <tbody> <tr> <td>000b</td> <td>00h</td> <td>~ 0.65 x V<sub>CC</sub></td> </tr> <tr> <td>010b</td> <td>20h</td> <td>~ 0.77 x V<sub>CC</sub> (RESET)</td> </tr> <tr> <td>011b</td> <td>30h</td> <td>~ 0.83 x V<sub>CC</sub></td> </tr> </tbody> </table>	A[6:4]	Hex code	V <sub>COMH</sub> deselect level	000b	00h	~ 0.65 x V <sub>CC</sub>	010b	20h	~ 0.77 x V <sub>CC</sub> (RESET)	011b	30h	~ 0.83 x V <sub>CC</sub>
A[6:4]	Hex code	V <sub>COMH</sub> deselect level																					
000b	00h	~ 0.65 x V <sub>CC</sub>																					
010b	20h	~ 0.77 x V <sub>CC</sub> (RESET)																					
011b	30h	~ 0.83 x V <sub>CC</sub>																					
00	E3	1	1	1	0	0	0	1	1	NOP	Command for no operation												

**2. Scrolling Command Table**

D/C#	Hex	D7	D6	D5	D4	D3	D2	D1	D0	Command	Description									
00	26/27	0	0	1	0	0	1	1	X <sub>0</sub>	Continuous Horizontal	26h, X[0]=0, Right Horizontal Scroll 27h, X[0]=1, Left Horizontal Scroll									
00	A[7:0]	0	0	0	0	0	0	0	0	Scroll Setup	(Horizontal scroll by 1 column)									
00	B[2:0]	*	*	*	*	*	B <sub>2</sub>	B <sub>1</sub>	B <sub>0</sub>		A[7:0] : Dummy byte (Set as 00h)									
00	C[2:0]	*	*	*	*	*	C <sub>2</sub>	C <sub>1</sub>	C <sub>0</sub>		B[2:0] : Define start page address									
00	D[2:0]	*	*	*	*	*	D <sub>2</sub>	D <sub>1</sub>	D <sub>0</sub>											
00	E[7:0]	0	0	0	0	0	0	0	0											
00	F[7:0]	1	1	1	1	1	1	1	1											
											<table border="1"> <tbody> <tr> <td>000b – PAGE0</td> <td>011b – PAGE3</td> <td>110b – PAGE6</td> </tr> <tr> <td>001b – PAGE1</td> <td>100b – PAGE4</td> <td>111b – PAGE7</td> </tr> <tr> <td>010b – PAGE2</td> <td>101b – PAGE5</td> <td></td> </tr> </tbody> </table>	000b – PAGE0	011b – PAGE3	110b – PAGE6	001b – PAGE1	100b – PAGE4	111b – PAGE7	010b – PAGE2	101b – PAGE5	
000b – PAGE0	011b – PAGE3	110b – PAGE6																		
001b – PAGE1	100b – PAGE4	111b – PAGE7																		
010b – PAGE2	101b – PAGE5																			
											C[2:0] : Set time interval between each scroll step in terms of frame frequency  <table border="1"> <tbody> <tr> <td>000b – 5 frames</td> <td>100b – 3 frames</td> </tr> <tr> <td>001b – 64 frames</td> <td>101b – 4 frames</td> </tr> <tr> <td>010b – 128 frames</td> <td>110b – 25 frame</td> </tr> <tr> <td>011b – 256 frames</td> <td>111b – 2 frame</td> </tr> </tbody> </table>	000b – 5 frames	100b – 3 frames	001b – 64 frames	101b – 4 frames	010b – 128 frames	110b – 25 frame	011b – 256 frames	111b – 2 frame	
000b – 5 frames	100b – 3 frames																			
001b – 64 frames	101b – 4 frames																			
010b – 128 frames	110b – 25 frame																			
011b – 256 frames	111b – 2 frame																			
											D[2:0] : Define end page address  <table border="1"> <tbody> <tr> <td>000b – PAGE0</td> <td>011b – PAGE3</td> <td>110b – PAGE6</td> </tr> <tr> <td>001b – PAGE1</td> <td>100b – PAGE4</td> <td>111b – PAGE7</td> </tr> <tr> <td>010b – PAGE2</td> <td>101b – PAGE5</td> <td></td> </tr> </tbody> </table> The value of D[2:0] must be larger or equal to B[2:0]	000b – PAGE0	011b – PAGE3	110b – PAGE6	001b – PAGE1	100b – PAGE4	111b – PAGE7	010b – PAGE2	101b – PAGE5	
000b – PAGE0	011b – PAGE3	110b – PAGE6																		
001b – PAGE1	100b – PAGE4	111b – PAGE7																		
010b – PAGE2	101b – PAGE5																			
											E[7:0] : Dummy byte (Set as 00h)									
											F[7:0] : Dummy byte (Set as FFh)									

2. Scrolling Command Table																			
D/C#	Hex	D7	D6	D5	D4	D3	D2	D1	D0	Command	Description								
0	29/2A	0	0	1	0	1	0	X <sub>1</sub>	X <sub>0</sub>	Continuous	29h, X <sub>1</sub> X <sub>0</sub> =01b : Vertical and Right Horizontal Scroll								
0	A[2:0]	0	0	0	0	0	0	0	0	Vertical and	2Ah, X <sub>1</sub> X <sub>0</sub> =10b : Vertical and Left Horizontal Scroll								
0	B[2:0]	*	*	*	*	*	B <sub>2</sub>	B <sub>1</sub>	B <sub>0</sub>	Horizontal	(Horizontal scroll by 1 column)								
0	C[2:0]	*	*	*	*	*	C <sub>2</sub>	C <sub>1</sub>	C <sub>0</sub>	Scroll Setup	A[7:0] : Dummy byte								
0	D[2:0]	*	*	*	*	*	D <sub>2</sub>	D <sub>1</sub>	D <sub>0</sub>										
0	E[5:0]	*	*	E <sub>5</sub>	E <sub>4</sub>	E <sub>3</sub>	E <sub>2</sub>	E <sub>1</sub>	E <sub>0</sub>										
B[2:0] : Define start page address <table border="1" style="margin-left: 20px;"> <tr> <td>000b – PAGE0</td> <td>011b – PAGE3</td> <td>110b – PAGE6</td> </tr> <tr> <td>001b – PAGE1</td> <td>100b – PAGE4</td> <td>111b – PAGE7</td> </tr> <tr> <td>010b – PAGE2</td> <td>101b – PAGE5</td> <td></td> </tr> </table>											000b – PAGE0	011b – PAGE3	110b – PAGE6	001b – PAGE1	100b – PAGE4	111b – PAGE7	010b – PAGE2	101b – PAGE5	
000b – PAGE0	011b – PAGE3	110b – PAGE6																	
001b – PAGE1	100b – PAGE4	111b – PAGE7																	
010b – PAGE2	101b – PAGE5																		
C[2:0] : Set time interval between each scroll step in terms of frame frequency <table border="1" style="margin-left: 20px;"> <tr> <td>000b – 5 frames</td> <td>100b – 3 frames</td> </tr> <tr> <td>001b – 64 frames</td> <td>101b – 4 frames</td> </tr> <tr> <td>010b – 128 frames</td> <td>110b – 25 frame</td> </tr> <tr> <td>011b – 256 frames</td> <td>111b – 2 frame</td> </tr> </table>											000b – 5 frames	100b – 3 frames	001b – 64 frames	101b – 4 frames	010b – 128 frames	110b – 25 frame	011b – 256 frames	111b – 2 frame	
000b – 5 frames	100b – 3 frames																		
001b – 64 frames	101b – 4 frames																		
010b – 128 frames	110b – 25 frame																		
011b – 256 frames	111b – 2 frame																		
D[2:0] : Define end page address <table border="1" style="margin-left: 20px;"> <tr> <td>000b – PAGE0</td> <td>011b – PAGE3</td> <td>110b – PAGE6</td> </tr> <tr> <td>001b – PAGE1</td> <td>100b – PAGE4</td> <td>111b – PAGE7</td> </tr> <tr> <td>010b – PAGE2</td> <td>101b – PAGE5</td> <td></td> </tr> </table> The value of D[2:0] must be larger or equal to B[2:0]											000b – PAGE0	011b – PAGE3	110b – PAGE6	001b – PAGE1	100b – PAGE4	111b – PAGE7	010b – PAGE2	101b – PAGE5	
000b – PAGE0	011b – PAGE3	110b – PAGE6																	
001b – PAGE1	100b – PAGE4	111b – PAGE7																	
010b – PAGE2	101b – PAGE5																		
E[5:0] : Vertical scrolling offset e.g. E[5:0]= 01h refer to offset =1 row E[5:0] =3Fh refer to offset =63 rows																			
<b>Note</b> (1) No continuous vertical scrolling is available.																			
0	2E	0	0	1	0	1	1	1	0	Deactivate scroll	Stop scrolling that is configured by command 26h/27h/29h/2Ah.  <b>Note</b> (1) After sending 2Eh command to deactivate the scrolling action, the ram data needs to be rewritten.								
0	2F	0	0	1	0	1	1	1	1	Activate scroll	Start scrolling that is configured by the scrolling setup commands :26h/27h/29h/2Ah with the following valid sequences:  Valid command sequence 1: 26h ;2Fh. Valid command sequence 2: 27h ;2Fh. Valid command sequence 3: 29h ;2Fh. Valid command sequence 4: 2Ah ;2Fh.  For example, if “26h; 2Ah; 2Fh.” commands are issued, the setting in the last scrolling setup command, i.e. 2Ah in this case, will be executed. In other words, setting in the last scrolling setup command overwrites the setting in the previous scrolling setup commands.								

2. Scrolling Command Table											
D/C#	Hex	D7	D6	D5	D4	D3	D2	D1	D0	Command	Description
0	A3	1	0	1	0	0	0	1	1	Set Vertical Scroll Area	A[5:0] : Set No. of rows in top fixed area. The No. of rows in top fixed area is referenced to the top of the GDDRAM (i.e. row 0).[RESET = 0]  B[6:0] : Set No. of rows in scroll area. This is the number of rows to be used for vertical scrolling. The scroll area starts in the first row below the top fixed area. [RESET = 64]  <b>Note</b> (1) A[5:0]+B[6:0] <= MUX ratio (2) B[6:0] <= MUX ratio (3a) Vertical scrolling offset (E[5:0] in 29h/2Ah) < B[6:0] (3b) Set Display Start Line (X <sub>5</sub> X <sub>4</sub> X <sub>3</sub> X <sub>2</sub> X <sub>1</sub> X <sub>0</sub> of 40h~7Fh) < B[6:0] (4) The last row of the scroll area shifts to the first row of the scroll area. (5) For 64d MUX display A[5:0] = 0, B[6:0]=64 : whole area scrolls A[5:0]= 0, B[6:0] < 64 : top area scrolls A[5:0] + B[6:0] < 64 : central area scrolls A[5:0] + B[6:0] = 64 : bottom area scrolls
0	A[5:0]	*	*	A <sub>5</sub>	A <sub>4</sub>	A <sub>3</sub>	A <sub>2</sub>	A <sub>1</sub>	A <sub>0</sub>		
0	B[6:0]	*	B <sub>6</sub>	B <sub>5</sub>	B <sub>4</sub>	B <sub>3</sub>	B <sub>2</sub>	B <sub>1</sub>	B <sub>0</sub>		

3. Advance Graphic Command Table																							
D/C#	Hex	D7	D6	D5	D4	D3	D2	D1	D0	Command	Description												
0	23	0	0	1	0	0	0	1	1	Set Fade Out and Blinking	A[5:4] = 00b Disable Fade Out / Blinking Mode[RESET]  A[5:4] = 10b Enable Fade Out mode. Once Fade Mode is enabled, contrast decrease gradually to all pixels OFF. Output follows RAM content when Fade mode is disabled.  A[5:4] = 11b Enable Blinking mode. Once Blinking Mode is enabled, contrast decrease gradually to all pixels OFF and then contrast increase gradually to normal display. This process loop continuously until the Blinking mode is disabled.  A[3:0] : Set time interval for each fade step  <table border="1" style="margin-left: 20px;"> <tr> <th>A[3:0]</th> <th>Time interval for each fade step</th> </tr> <tr> <td>0000b</td> <td>8 Frames</td> </tr> <tr> <td>0001b</td> <td>16 Frames</td> </tr> <tr> <td>0010b</td> <td>24 Frames</td> </tr> <tr> <td style="text-align: center;">:</td> <td></td> </tr> <tr> <td>1111b</td> <td>128 Frames</td> </tr> </table>	A[3:0]	Time interval for each fade step	0000b	8 Frames	0001b	16 Frames	0010b	24 Frames	:		1111b	128 Frames
A[3:0]	Time interval for each fade step																						
0000b	8 Frames																						
0001b	16 Frames																						
0010b	24 Frames																						
:																							
1111b	128 Frames																						
0	A[6:0]	*	*	A <sub>5</sub>	A <sub>4</sub>	A <sub>3</sub>	A <sub>2</sub>	A <sub>1</sub>	A <sub>0</sub>														

Note  
 (1) Refer to section 10.3.1 for details.



3. Advance Graphic Command Table											
D/C#	Hex	D7	D6	D5	D4	D3	D2	D1	D0	Command	Description
0	D6	1	1	0	1	0	1	1	0	Set Zoom In	A[0] = 0b Disable Zoom in Mode[RESET]
0	A[0]	0	0	0	0	0	0	0	A0		A[0] = 1b Enable Zoom in Mode
Note											
<sup>(1)</sup> The panel must be in alternative COM pin configuration (command DAh A[4] =1)											
<sup>(2)</sup> Refer to section 10.3.2 for details.											

**Note**

(1) “\*” stands for “Don’t care”.

**n INITIALIZATION CODE**

```
void InitOLED MASTER SSD1308(void)
```

```
MainOLED WCom(0xAE) //DOT MARTIX DISPLAY OFF

MainOLED WCom(0x00) //SET COLUMN ADDRESS
MainOLED WCom(0x10)

MainOLED WCom(0x40) //SET DISPLAY START LINE(40H-7FH)

MainOLED WCom(0xA1) //SET SEGMENT RE-MAP(0A0H-0A1H)
MainOLED WCom(0xA4) //ENTIRE DISPLAY OFF(0A4H-0A5H)
MainOLED WCom(0xA6) //SET NORMAL DISPLAY(0A6H-0A7H)

MainOLED WCom(0xA8) //SET MULTIPLEX RATIO 64
MainOLED WCom(0x3F)

MainOLED WCom(0xC8) //COM SCAN COM1-COM64(0C8H,0C0H)

MainOLED WCom(0xD3) //SET DISPLAY OFFSET(OOH-3FH)
MainOLED WCom(0x00)

MainOLED WCom(0x81) //CONTARST CONTROL(00H-0FFH)
MainOLED WCom(Contrast)

MainOLED WCom(0xD5) //SET FRAME FREQUENCY
MainOLED WCom(0x70)
MainOLED WCom(0xD9) //SET PRE CHARGE PERIOD
MainOLED WCom(0x21)

MainOLED WCom(0xDA) //COM PIN CONFIGURATION(02H,12H)
MainOLED WCom(0x12)

MainOLED WCom(0xDB) //SET VCOM DESELECT LEVEL(035H)
MainOLED WCom(0x35)

MainOLED WCom(0xAD) //External or internal IREF Selection
MainOLED WCom(0x00)

Delaysms(10)
MainOLED WCom(0xAF) //DSPLAY ON
```

## n SCHEMATIC EXAMPLE

### ◆4-wire Serial Interface Application Circuit(External $V_{PP}=12.0V$ ):

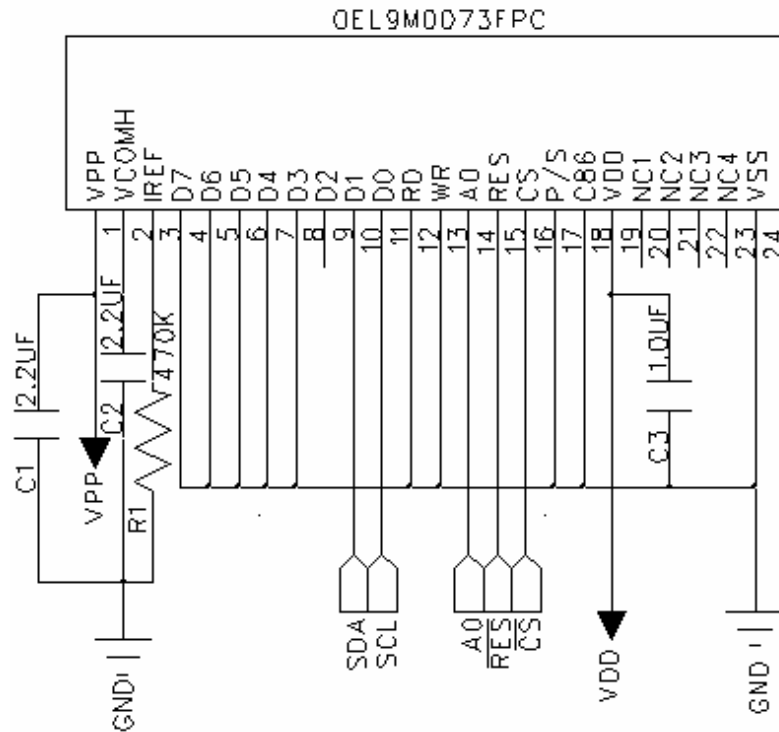

### ◆8080 Series Interface Application Circuit(External $V_{PP}=12.0V$ ):

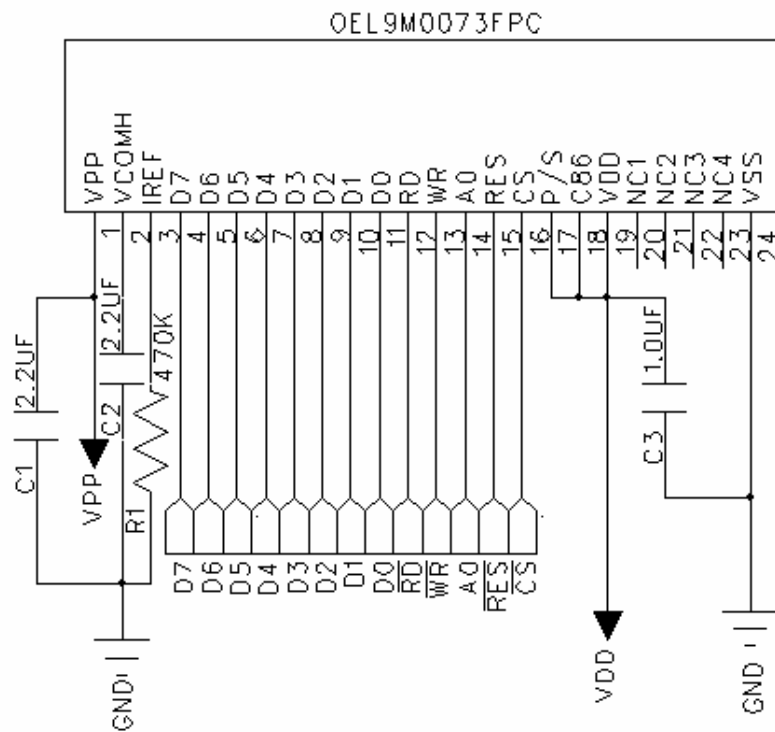

### ◆ IIC Interface Application Circuit(External $V_{PP}=12.0V$ ):

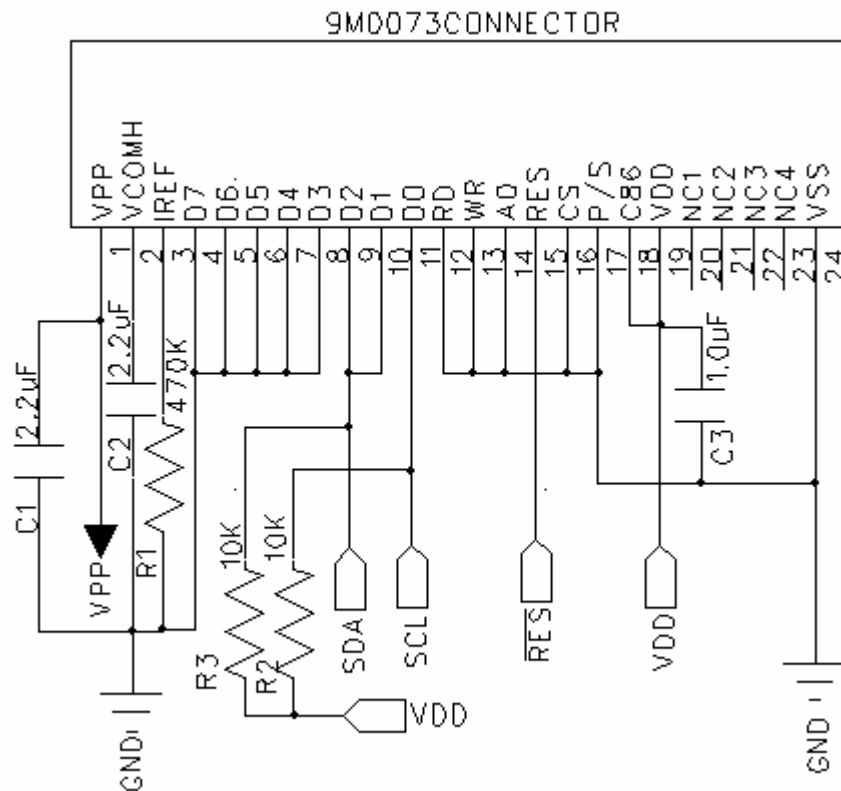

#### NOTE:

1. The  $V_{PP}$  should connect an external voltage;
2. When external IREF is used, a resistor should be connected between this pin and VSS to maintain the IREF current at 19uA, Voltage at IREF pin =  $V_{pp}-3V$ ;  
For  $V_{pp} = 12V$ ,  $R1 = (Voltage\ at\ IREF - VSS) / IREF = (12 - 3.1) / 19\ \mu A \approx 470K\Omega$ ;
3. In SPI mode ,the read function is not possible;
4. The capacitors and resistors' value is recommended value. Select appropriate value against module application.

## n RELIABILITY TESTS

Item		Condition	Criterion
High Temperature Storage (HTS)		80±2°C, 200 hours	1. After testing, the function test is ok. 2. After testing, no addition to the defect. 3. After testing, the change of luminance should be within +/- 50% of initial value. 4. After testing, the change for the mono and area color must be within (+/-0.02, +/-0.02) and for the full color it must be within (+/-0.04, +/-0.04) of initial value based on 1931 CIE coordinates. 5. After testing, the change of total current consumption should be within +/- 50% of initial value.
High Temperature Operating (HTO)		70±2°C, 96 hours	
Low Temperature Storage (LTS)		-30±2°C, 200 hours	
Low Temperature Operating (LTO)		-20±2°C, 96 hours	
High Temperature / High Humidity Storage (HTHHS)		50±3°C, 90%±3%RH, 120 hours	
Thermal Shock (Non-operation) (TS)		-20±2°C ~ 25°C ~ 70±2°C (30min) (5min) (30min) 10cycles	
Vibration (Packing)	10~55~10Hz, amplitude 1.5mm, 1 hour for each direction x, y, z	1. One box for each test. 2. No addition to the cosmetic and the electrical defects.	
Drop (Packing)	Height : 1 m, each time for 6 sides, 3 edges, 1 angle		
ESD (finished product housing)	±4kV (R: 330Ω C: 150pF, 10times, air discharge)	1. After testing, cosmetic and electrical defects should not happen. 2. In case of malfunction or defect caused by ESD damage, it would be judged as a good part if it would be recovered to normal state after resetting.	

Note: 1) For each reliability test, the sample quantity is 3, and only for one test item.

2) The HTHHS test is requested the Pure Water(Resistance > 10MΩ).

3) The test should be done after 2 hours of recovery time in normal environment.

## OUTGOING QUALITY CONTROL SPECIFICATION

### ◆Standard

According to GB/T2828.1-2003/ISO 2859-1: 1999 and ANSI/ASQC Z1.4-1993, General Inspection Level II.

### ◆Definition

- 1 Major defect : The defect that greatly affect the usability of product.
- 2 Minor defect : The other defects, such as cosmetic defects, etc.
- 3 Definition of inspection zone:

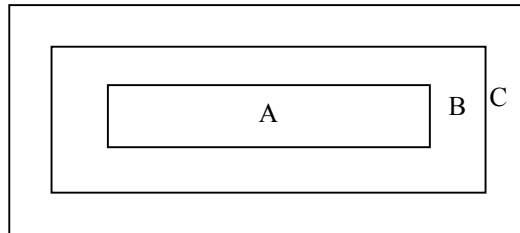

Zone A: Active Area

Zone B: Viewing Area except Zone A

Zone C: Outside Viewing Area

Note: As a general rule, visual defects in Zone C are permissible, when it is no trouble of quality and assembly to customer s product.

### ◆Inspection Methods

- 1 The general inspection : under 20W x 2 or 40W fluorescent light, about 30cm viewing distance, within 45° viewing angle, under 25±5 °C.

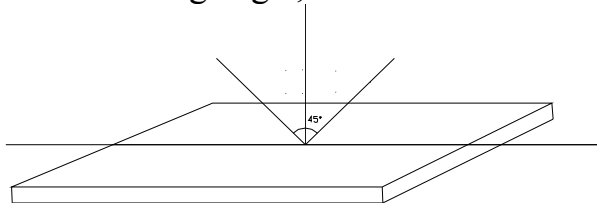

- 2 The luminance and color coordinate inspection : By PR705 or BM-7 or the equal equipments, in the dark room, under 25±5 °C.

### ◆Inspection Criteria

- 1 Major defect : AQL= 0.65

Item	Criterion
Function Defect	1. No display or abnormal display is not accepted
	2. Open or short is not accepted.
	3. Power consumption exceeding the spec is not accepted.
Outline Dimension	Outline dimension exceeding the spec is not accepted.
Glass Crack	Glass crack tends to enlarge is not accepted.

## 2 Minor Defect : AQL= 1.5

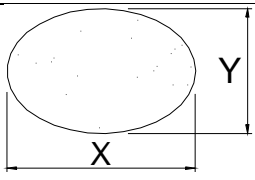
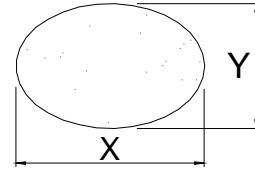
Item	Criterion			
Spot Defect (dimming and lighting spot)	Size (mm)		Accepted Qty	
			Area A + Area B	Area C
		$\Phi \leq 0.07$	Ignored	
		$0.07 < \Phi \leq 0.10$	3	Ignored
		$0.10 < \Phi \leq 0.15$	1	
$0.15 < \Phi$		0		
Note : $\Phi = (x + y) / 2$				
Line Defect (dimming and lighting line)	L ( Length ) : mm	W ( Width ) : mm	Area A + Area B	Area C
	/	$W \leq 0.02$	Ignored	
	$L \leq 3.0$	$0.02 < W \leq 0.03$	2	Ignored
	$L \leq 2.0$	$0.03 < W \leq 0.05$	1	
	/	$0.05 < W$	As spot defect	
Remarks: The total of spot defect and line defect shall not exceed 4 pcs. The distance between two lines defects must exceed 1 mm				
Polarizer Stain	Stain which can be wiped off lightly with a soft cloth or similar cleaning is accepted, otherwise, according to the Spot Defect and the Line Defect.			
Polarizer Scratch	1. If scratch can be seen during operation, according to the criterions of the Spot Defect and the Line Defect.			
	2. If scratch can be seen only under non-operation or some special angle, the criterion is as below :			
	L ( Length ) : mm	W ( Width ) : mm	Area A + Area B	Area C
	/	$W \leq 0.02$	Ignore	
	$3.0 < L \leq 5.0$	$0.02 < W \leq 0.04$	2	Ignore
	$L \leq 3.0$	$0.04 < W \leq 0.06$	1	
/	$0.06 < W$	0		
Polarizer Air Bubble	Size		Area A + Area B	Area C
		$\Phi \leq 0.20$	Ignored	
		$0.20 < \Phi \leq 0.30$	2	Ignored
		$0.30 < \Phi \leq 0.50$	1	
		$0.50 < \Phi$	0	

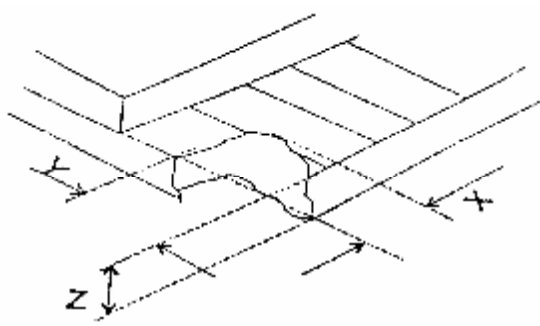
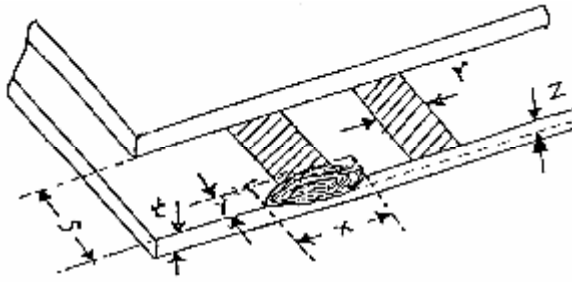
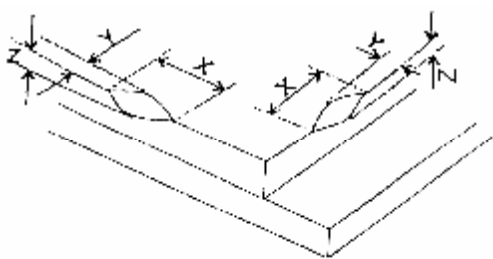
Glass Defect (Glass Chipped )	1. On the corner  <table border="1" style="margin-left: auto;"> <thead> <tr> <th colspan="2">(mm)</th> </tr> </thead> <tbody> <tr> <td>x</td> <td><math>\leq 1.5</math></td> </tr> <tr> <td>y</td> <td><math>\leq 1.5</math></td> </tr> <tr> <td>z</td> <td><math>\leq t</math></td> </tr> </tbody> </table>	(mm)		x	$\leq 1.5$	y	$\leq 1.5$	z	$\leq t$
	(mm)								
	x	$\leq 1.5$							
	y	$\leq 1.5$							
z	$\leq t$								
2. On the bonding edge  <table border="1" style="margin-left: auto;"> <thead> <tr> <th colspan="2">(mm)</th> </tr> </thead> <tbody> <tr> <td>x</td> <td><math>\leq a / 4</math></td> </tr> <tr> <td>y</td> <td><math>\leq s / 3 \ \&amp;\leq 0.7</math></td> </tr> <tr> <td>z</td> <td><math>\leq t</math></td> </tr> </tbody> </table>	(mm)		x	$\leq a / 4$	y	$\leq s / 3 \ \&\leq 0.7$	z	$\leq t$	
(mm)									
x	$\leq a / 4$								
y	$\leq s / 3 \ \&\leq 0.7$								
z	$\leq t$								
3. On the other edges  <table border="1" style="margin-left: auto;"> <thead> <tr> <th colspan="2">(mm)</th> </tr> </thead> <tbody> <tr> <td>x</td> <td><math>\leq a / 8</math></td> </tr> <tr> <td>y</td> <td><math>\leq 0.7</math></td> </tr> <tr> <td>z</td> <td><math>\leq t</math></td> </tr> </tbody> </table>	(mm)		x	$\leq a / 8$	y	$\leq 0.7$	z	$\leq t$	
(mm)									
x	$\leq a / 8$								
y	$\leq 0.7$								
z	$\leq t$								
Note: t: glass thickness    s: pad width    a: the length of the edge									
TCP Defect	Crack, deep fold and deep pressure mark on the TCP are not accepted								
Pixel Size	The tolerance of display pixel dimension should be within $\pm 20\%$ of the spec								
Luminance	Refer to the spec or the reference sample								
Color	Refer to the spec or the reference sample								

## CAUTIONS IN USING OLED MODULE

### ◆ Precautions For Handling OLED Module:

1. OLED module consists of glass and polarizer. Pay attention to the following items when handling:
  - i. Avoid drop from high, avoid excessive impact and pressure.
  - ii. Do not touch, push or rub the exposed polarizers with anything harder than an HB pencil lead.
  - iii. If the surface becomes dirty, breathe on the surface and gently wipe it off with a soft dry cloth. If it is terrible dirty, moisten the soft cloth with Isopropyl alcohol or Ethyl alcohol. Other solvents may damage the polarizer. Especially water, Ketone and Aromatic solvents.
  - iv. Wipe off saliva or water drops immediately, contact the polarizer with water over a long period of time may cause deformation.
  - v. Please keep the temperature within specified range for use and storage. Polarization degradation, bubble generation or polarizer peeling-off may occur with high temperature and high humidity.
  - vi. Condensation on the surface and the terminals due to cold or anything will damage, stain or dirty the polarizer, so make it clean as the way of iii.
2. Do not attempt to disassemble or process the OLED Module.
3. Make sure the TCP or the FPC of the Module is free of twisting, warping and distortion, do not pull or bend them forcefully, especially the soldering pins. On the other side, the SLIT part of the TCP is made to bend in the necessary case.
4. When assembling the module into other equipment, give the glass enough space to avoid excessive pressure on the glass, especially the glass cover which is much more fragile.
5. Be sure to keep the air pressure under 120 kPa, otherwise the glass cover is to be cracked.
6. Be careful to prevent damage by static electricity:
  - i. Be sure to ground the body when handling the OLED Modules.
  - ii. All machines and tools required for assembling, such as soldering irons, must be properly grounded.
  - iii. Do not assemble and do no other work under dry conditions to reduce the amount of static electricity generated. A relative humidity of 50%-60% is recommended.
  - iv. Peel off the protective film slowly to avoid the amount of static electricity generated.
  - v. Avoid to touch the circuit, the soldering pins and the IC on the Module by the body.
  - vi. Be sure to use anti-static package.
7. Contamination on terminals can cause an electrochemical reaction and corrode the terminal circuit, so make it clean anytime.
8. All terminals should be open, do not attach any conductor or semiconductor on the terminals.
9. When the logic circuit power is off, do not apply the input signals.
10. Power on sequence:  $V_{DD} \rightarrow V_{CC}$ , and power off sequence:  $V_{CC} \rightarrow V_{DD}$ .
11. Be sure to keep temperature, humidity and voltage within the ranges of the spec, otherwise shorten Module's life time, even make it damaged.
12. Be sure to drive the OLED Module following the Specification and datasheet of IC controller, otherwise something wrong may be seen.

13. When displaying images, keep them rolling, and avoid one fixed image displaying more than 30 seconds, otherwise the residue image is to be seen. This is the speciality of OLED.

#### ◆ **Precautions For Soldering OLED Module:**

1. Soldering temperature :  $260^{\circ}\text{C} \pm 10^{\circ}\text{C}$ .
2. Soldering time : 3-4 sec.
3. Repeating time : no more than 3 times.
4. If soldering flux is used, be sure to remove any remaining flux after finishing soldering operation. (This does not apply in the case of a non-halogen type of flux.) It is recommended to protect the surface with a cover during soldering to prevent any damage due to flux spatters.

#### ◆ **Precautions For Storing OLED Module:**

1. Be sure to store the OLED Module in the vacuum bag with dessicant.
2. If the Module can not be used up in 1 month after the bag being opened, make sure to seal the Module in the vacuum bag with dessicant again.
3. Store the Module in a dark place, do not expose to sunlight or fluorescent light.
4. The polarizer surface should not touch any other objects. It is recommended to store the Module in the shipping container.
5. It is recommended to keep the temperature between  $0^{\circ}\text{C}$  and  $30^{\circ}\text{C}$  , the relative humidity not over 60%.

#### ◆ **Limited Warranty**

Unless relevant quality agreements signed with customer and law enforcement, for a period of 12 months from date of production, all products (except automotive products) Multi-Inno will replace or repair any of its OLED modules which are found to be functional defect when inspected in accordance with Multi-Inno OLED acceptance standards (copies available upon request). Cosmetic/visual defects must be returned to Multi-Inno within 90 days of shipment. Confirmation of such date should be based on freight documents. The warranty liability of Multi-Inno is limited to repair and/or replacement on the terms above. Multi-Inno will not be responsible for any subsequent or consequential events.

#### ◆ **Return OLED Module Under Warranty:**

1. No warranty in the case that the precautions are disregarded.
2. Module repairs will be invoiced to the customer upon mutual agreement. Modules must be returned with sufficient description of the failures or defects.

#### ◆ **PRIOR CONSULT MATTER**

1. For Multi-Inno standard products , we keep the right to change material ,process ... for improving the product property without any notice on our customer.
2. If you have special requirement about reliability condition, please let us know before you start the test on our samples.