



MULTI-INNO TECHNOLOGY CO., LTD.

www.multi-inno.com

TOUCH PANEL SPECIFICATION

Model : MI0970CBP-C

This module uses ROHS material

For Customer's Acceptance:

| | |
|----------|--|
| Customer | |
| Approved | |
| Comment | |

This specification may change without prior notice in order to improve performance or quality. Please contact Multi-Inno for updated specification and product status before design for this product or release of this order.

| | |
|---------------|------------|
| Revision | 1.0 |
| Engineering | |
| Date | 2013-10-12 |
| Our Reference | |

**REVISION RECORD**

| REV NO. | REV DATE | CONTENTS | REMARKS |
|---------|------------|---------------|---------|
| 1.0 | 2013-10-12 | First Release | |
| | | | |
| | | | |
| | | | |
| | | | |
| | | | |
| | | | |
| | | | |
| | | | |
| | | | |
| | | | |
| | | | |
| | | | |
| | | | |
| | | | |
| | | | |
| | | | |
| | | | |
| | | | |
| | | | |
| | | | |
| | | | |

**CONTENT:目录**

- 1. General Specification**
产品规格
- 2. Basic features**
基本特性
- 3. Standard condition**
标准条件
- 4. Electrical and optical characteristic**
电气光学特性
- 5. Reliability Test Conditions**
可靠性测试条件
 - 5-1 Environment test**
环境测试
 - 5-2 Mechanical Test**
机械性能测试
- 6. Interface description**
接口定义
- 7. Drawing**
图纸
- 8. Cosmetic standard**
检查标准
- 9. Package**
包装
- 10. Application notes**
使用注意事项
- 11. Storage condition and expiring time**
存储条件和保质期

**1. General Specification 产品规格**

| Item 项目 | Specification 规格 | Remarks 备注 |
|--------------------------|----------------------------------|------------|
| 1-1 Product name 产品名称 | Capacitive Touch Panel 电容式触摸屏 | / |
| 1-2 Product No. 产品编号 | MI0970CBP-C | / |
| 1-3 Drawing No. 图纸编号 | - | / |
| 1-4 Sample No. 样品编号 | - | / |

2 .Basic features 基本特性

| Item 项目 | Specification 规格 | Remarks 备注 |
|---------------------------------|-----------------------------------|-------------------------|
| 2-1. Dimension 尺寸 | / | / |
| 2-1-1 Outline Dimension 外形尺寸 | 236.70*183.6 | Unit 单位: mm |
| 2-1-2 Viewing Area 可视区 | 197.61*148.46 | Unit 单位: mm |
| 2-1-3 Active Area 动作区 | / | Unit 单位: mm |
| 2-2. Construction 结构 | Materials used 所用材料 | Thickness: mm 厚度: mm |
| 2-2-1 First Layer 第一层 | <u>ITO Glass</u> <u>ITO 玻璃</u> | <u>1.1</u> |
| 2-2-2 Second Layer 第二层 | / | / |
| 2-2-3 Third Layer 第三层 | / | / |
| 2-2-4 Forth Layer 第四层 | / | / |
| 2-2-5 Fifth Layer 第五层 | / | / |
| 2-3 IC part number IC 型号 | FT5606 | / |
| 2-4 Surface Hardness 表面硬度 | <u>6H</u> | Pressure 500 gf, 45 deg |



| | | |
|-----------------------------|--|--|
| 2-5 Scope 应用方式 | This specification applies for finger input capacitive touch panels. (Those mentioned in the individual specification shall be given priority.) 此规格适用在手指输入型电容式触摸屏（此处以提到的有特殊要求应优先考虑） | Make sure that there no any water on TP during using. Keep the power off when any water on TP until the water is wiped up. 触摸屏使用时必须保证没有水在表面。有水的情况请关掉电源直到水被完全擦拭干净。 |
| 2-6 Application 应用范围 | The product is touch panels used as the input devices for general electric appliances and OA equipment. 此产品是电容式触摸屏，常作为常用的电子器件和 OA 设备的输入装置 | / |
| 2-7 Operating range 工作范围 | Temperature: $-10^{\circ}\text{C} \sim 60^{\circ}\text{C}$ | Humidity: $\leq 40^{\circ}\text{C}$: 90%RH or less $40 \sim 60^{\circ}\text{C}$: 60%RH or less $> 60^{\circ}\text{C}$: 50%RH or less |
| 2-8 Storage range 存储范围 | Temperature: $-20^{\circ}\text{C} \sim 70^{\circ}\text{C}$ | |

3. Standard condition 标准条件

Do the examination and measurement under the following standard condition environment except there is especially specification in each item.

各项目内有指定的测试环境/条件除外，测试环境按以下标准条件

| | |
|--------------------|----------------------------|
| 3-1 Temperature 温度 | $25 \pm 5^{\circ}\text{C}$ |
| 3-2 Humidity 湿度 | $65 \pm 10\% \text{RH}$ |
| 3-3 Atmospheric 气压 | $96 \pm 10 \text{KPa}$ |

4. Electronical and optical characteristic 电气光学特性

| Item 项目 | Specification 规格 | | | | | Remarks 备注 |
|------------------------------------|------------------|-----|------|-----|------|---|
| 4-1 Response time 反应时间 | <200 ms | | | | | / |
| 4-2 Report rate 报点频率 | > 80 Hz | | | | | / |
| 4-3 Supply voltage for logic 电压 | Symbol | min | type | max | unit | After reliability test the, change of current is less than 50% of its initial value. 可靠性测试后，电流的变化不能超过初始值的 50% |
| | vdd | 2.8 | 3.3 | 3.6 | V | |
| 4-4 Supply current for logic 电流 | Active mode (mA) | | 15 | | | |
| | Sleep mode (uA) | | 70 | | | |
| 4-5 Resolution 分辨率 | 1024*768 | | | | | / |
| 4-6 Support points 触摸点数 | 10 | | | | | / |
| 4-7 interface 接口 | IIC | | | | | / |
| 4-8 Transmissivity 透过率 | > 85% | | | | | Total light test 白光测试 |

5. Reliability Test Conditions 可靠性测试条件

5-1 Environment test 环境测试



| Item 项目 | Specification 规格 | Remarks 备注 |
|--|--|--|
| 5-1-1 Storage Humidity Resistance 高温高湿存储 | 60°C x 90%RH x 240Hours | After reliability test the, change of current is less than 50% of its initial value. 可靠性测试后, 电流的变化不能超过初始值的 50% |
| t5-1-2 Storage Heat Resistance 高温存储 | 70°C x 240Hours | |
| 5-1-3 Storage Cold resistance 低温存储 | -20°C x 240Hours | |
| 5-1-4 Storage Thermal shock 冷热冲击 | -20°C (0.5hour) ~ 70°C (0.5hour) x 50 cycles | |

5-2 Mechanical Test 机械性能测试

| Item 项目 | Specification 规格 | Remarks 备注 |
|-------------------------------|--|--|
| 5-2-1 Steel ball test 钢球跌落 | Test High高度: 20cm Ball Weigh钢球重量: 100g Support Nothing in the middle of product 测试过程中产品中间没有支持物 | After test, product no broken and function OK is passed 测试之后产品没有破裂, 且功能 OK |
| 5-2-2 Package drop 包装跌落测试 | No damage to the product.(drop from 1 meter height) 包装从 1 米高处跌落无损伤 | |
| 5-2-3 FPC test FPC 测试 | Bending test 弯折测试 | |
| | Plug in and out Test 插拔测试 | Fifteen times插拔次数: 10 times |

6-1. Interface Description 接口定义

| PIN No. | PIN Name | Description |
|---------|----------|---|
| 1 | VDD | Power supply for touch panel |
| 2 | GND | Connect to ground |
| 3 | SCL | IC Clock, add a pull-up resistor (reference resistor: 4.7k) |
| 4 | SDA | IC Data, add a pull-up resistor (reference resistor: 4.7k). |
| 5 | INT | Interrupt signal (Low level is active), add a pull-up resistor (reference resistor: 4.7k) |
| 6 | RESET | Restart TP by a GPIO of host CPU (Low level is active) |

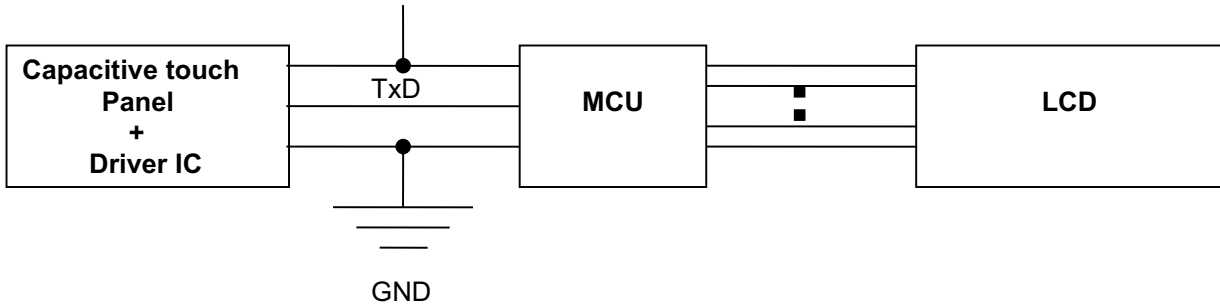
6-2 Block diagram 原理框图

Provided by MIT

Customer side

NOTES:

- ① IIC clock frequency: Max. 400 kHz;
- ② IIC 7bit addresses: 0x70;

7. Drawing 图纸

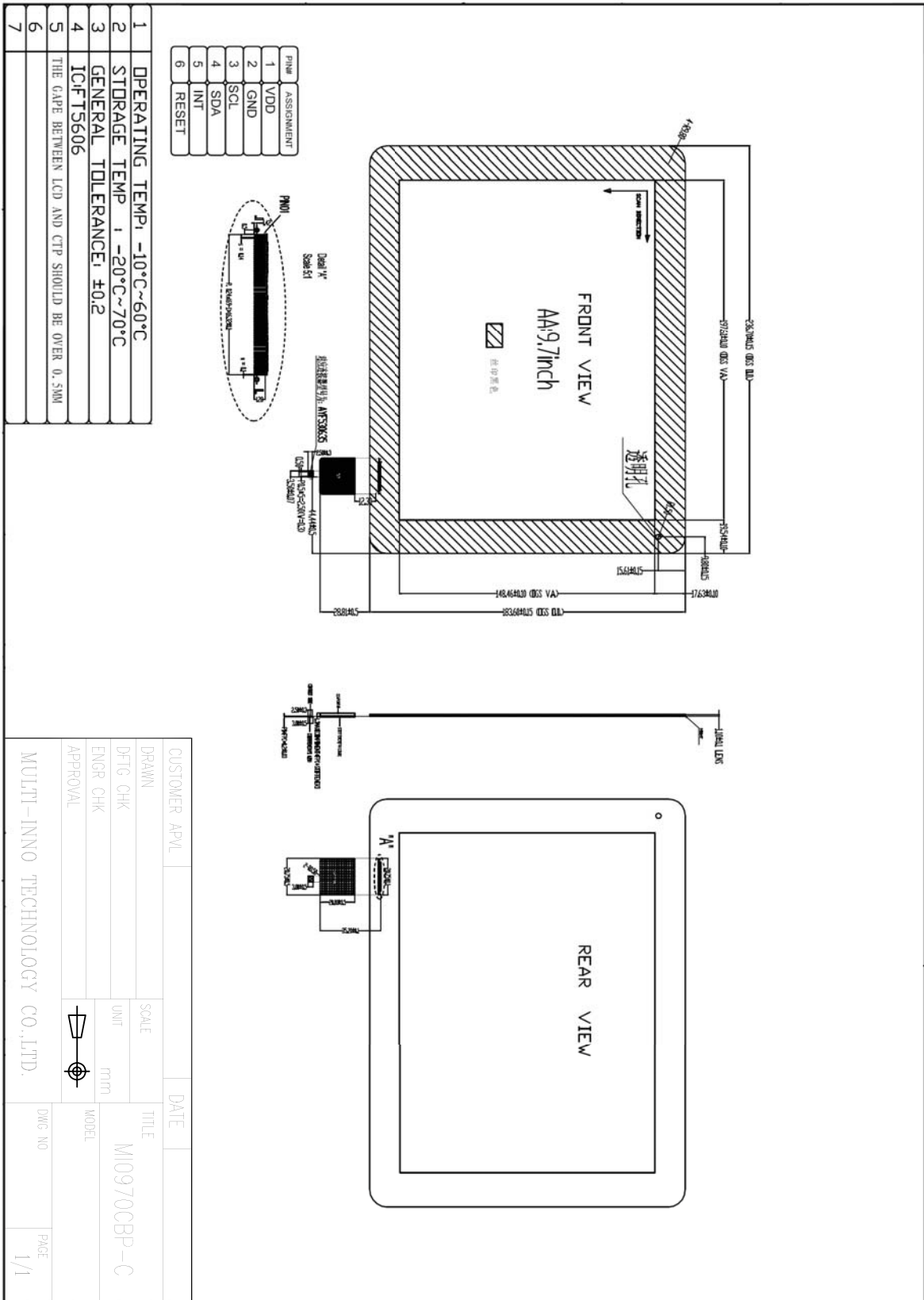

| | | | | | | | |
|--------------------------------|------|-------------|-------|------|-------|--------|------|
| CUSTOMER APVL | DATE | TITLE | SCALE | UNIT | MODEL | DWG NO | PAGE |
| DRAWN | | MI0970CBP-C | | MM | | | 1/1 |
| DTC CHK | | | | | | | |
| ENGR CHK | | | | | | | |
| APPROVAL | | | | | | | |
| MULTI-INNO TECHNOLOGY CO.,LTD. | | | | | | | |

8. Cosmetic standard 检查标准

1. 目的 Purpose

此标准是用于定义接受或拒绝触摸屏的标准

The specification is made to be used as the standard acceptance/rejection criteria for Touch Panel

2. 适用范围:

适用于信利光电生产的 6.5in 以上 CTP 产品

3. 定义 Definition

3.1 检查条件 Inspection condition:

检查距离: 30±5cm inspection distance: 30±5cm

3.2 照度要求: 500~700lux, Light illumination: 500~700lux

3.3 检查背景 backgrounds: 黑色背景 backgrounds: Black(Dark) backgrounds.

3.4 检查角度: -30~30 度; angle of visual: -30°~30°

3.5 检查顺序: 棱边—正面—反面 inspection order: side--front--rear

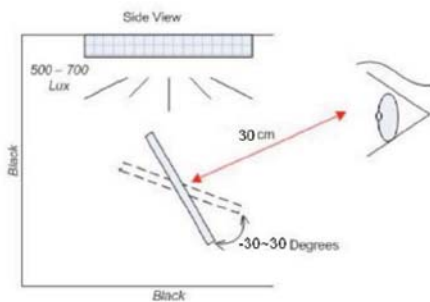

3.6 抽样方案: Sampling Plan

根据 GB/T2828.1-2003/ISO 2859-1: 1999 and ANSI/ASQC Z1.4-1993, 水平 II :

AQL: 重缺陷: 1.0 轻缺陷: 1.5

Sampling plan according to GB/T2828.1-2003/ISO 2859-1: 1999 and ANSI/ASQC Z1.4-1993, normal level 2 and based on:

Major defect: AQL 1.0 Minor defect: AQL 1.5

3.7 缺陷定义: Defect Definition

3.7.1 点状缺陷 Circular Defects:

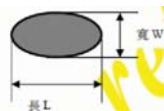

直径 D (diameter) = 1/2(L+W)

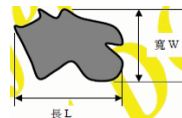

直径 D (diameter) = 1/2(L+W)

3.7.2 线状缺陷 Linear Defects:

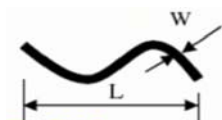

3.7.3 针孔 (透光) Pin hole

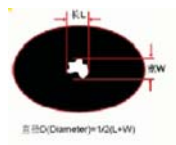

3.7.4 锯齿 Zigzag

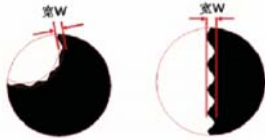

3.8 区域定义 Area Definition

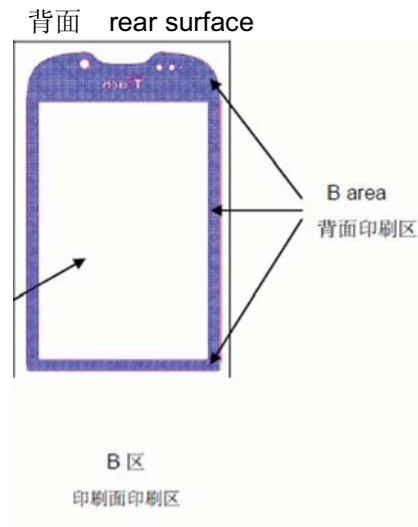
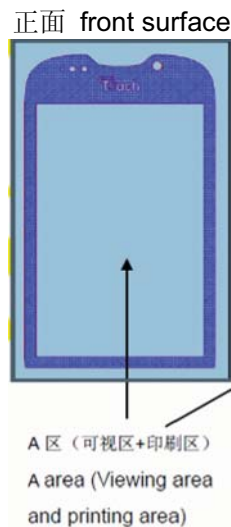

4. 备注 Remark

主要缺陷 Major Defect

主要缺陷包含开路，短路，触摸无反应，拖尾，漏笔和外部尺寸超出图纸设计。

All functional defects such as open, short, contrast differential, excess power consumption, smearing. Leakage, etc. And overall outline dimension beyond the drawing. Are classified as major defects.

缺陷计算方式、数量及间隔 Defects count、method、number and distance between defects.

1. 可擦拭的缺陷不计； The removable dirt is ignored
2. 线状缺陷以长度/宽度计算，点状缺陷以直径计算； Linear defects scaled by the length / width, dot defects scaled by diameter
3. 不良缺陷总允许个数为 10 个 Total quantity of defects is limited to 10 defects.
4. 可参照各客户提供的限度样本 Refer to the limit sample confirmed by Customer.



5 内容 content

| 项目 Item | 检查标准 Inspection Standard | |
|---|--------------------------|---|
| A面 A area 包括正面视窗区、印刷区和背面视窗区 Including view area/ BM area of front surface and view area of rear | 刮伤 scratch | 允许: 1. $W \leq 0.03\text{mm}$ 不计但不能聚集 2. $0.03\text{mm} \leq W \leq 0.05\text{mm}$; $L \leq 10\text{mm}$, $N \leq 5$, 间距大于 5mm 3. $0.05\text{mm} \leq W \leq 0.1\text{mm}$; $L \leq 5\text{mm}$, $N \leq 2$, 间距大于 3mm Accept: 1. $W \leq 0.03\text{mm}$ Ignored unless clustered |



| | | |
|--|--|---|
| area | | <p>2. $0.03\text{mm} \leq W \leq 0.05\text{mm}$; $L \leq 10\text{mm}$, $N \leq 5$, min 5mm(1") apart</p> <p>3. $0.05\text{mm} \leq W \leq 0.1\text{mm}$; $L \leq 5\text{mm}$, $N \leq 2$, 间距大于 3mm</p> <p>拒收: 超出以上规格</p> <p>Reject: Out of above spec</p> |
| | <p>黑/白点 Black/White spots 脏污 stain 异物 inclusion 锯齿 saw edge 针孔 pin holes</p> | <p>允许:</p> <p>1. $D \leq 0.15\text{mm}$ 不计,两个间距$\geq 2\text{mm}$</p> <p>2. $0.15\text{mm} \leq D \leq 0.25\text{mm}$; $N \leq 6$, 间距大于 5mm</p> <p>3. $0.2\text{mm} \leq D \leq 0.5\text{mm}$; $N \leq 4$</p> <p>Accept:</p> <p>1. $D \leq 0.15\text{mm}$ Ignore, min 2mm(1") apart</p> <p>2. $0.15\text{mm} \leq D \leq 0.25\text{mm}$; $N \leq 6$, min 5mm(1") apart</p> <p>3. $0.2\text{mm} \leq D \leq 0.5\text{mm}$; $N \leq 4$</p> <p>拒收: 超出以上规格</p> <p>Reject: Out of above spec</p> |
| | <p>气泡 Bubble</p> | <p>允许:</p> <p>1. $D \leq 0.1\text{mm}$ 不计,两个间距$\geq 2\text{mm}$</p> <p>2. $0.1\text{mm} \leq D \leq 0.25\text{mm}$; $N \leq 2$, 间距大于 5mm</p> <p>Accept:</p> <p>1. $D \leq 0.1\text{mm}$ Ignore, min 2mm(1") apart</p> <p>2. $0.1\text{mm} \leq D \leq 0.25\text{mm}$; $N \leq 2$, min 5mm(1") apart</p> <p>拒收: 超出以上规格</p> <p>Reject: Out of above spec</p> |
| | <p>毛屑/白边 Linear/foreign fiber</p> | <p>允许:</p> <p>1. $W \leq 0.03\text{mm}$ 不计但不能聚集</p> <p>2. $0.03\text{mm} \leq W \leq 0.05\text{mm}$; $L \leq 5\text{mm}$, $N \leq 3$,间距大于 5mm</p> <p>3. $0.05\text{mm} \leq W \leq 0.07\text{mm}$; $L \leq 2\text{mm}$, $N \leq 1$,</p> <p>Accept:</p> <p>1. $W \leq 0.03\text{mm}$ Ignored unless clustered</p> <p>2. $0.03\text{mm} \leq W \leq 0.05\text{mm}$; $L \leq 5\text{mm}$, $N \leq 3$, min 5mm(1") apart</p> <p>3. $0.05\text{mm} \leq W \leq 0.07\text{mm}$; $L \leq 2\text{mm}$, $N \leq 1$,</p> <p>拒收: 超出以上规格</p> <p>Reject: Out of above spec</p> |
| <p>A 面 A area 包括正面视窗区、印刷区和背面视窗区 Including view area/BM area of front surface and view area of rear surface</p> | <p>凹凸点 dent 鱼眼 fish eye</p> | <p>允许:</p> <p>1. $D \leq 0.1\text{mm}$ 不计,两个间距$\geq 2\text{mm}$</p> <p>2. $0.1\text{mm} \leq D \leq 0.2\text{mm}$; $N \leq 3$, 间距大于 5mm</p> <p>3. $0.2\text{mm} \leq D \leq 0.3\text{mm}$; $N \leq 2$, 间距大于 5mm</p> <p>4. $0.3\text{mm} \leq D \leq 0.4\text{mm}$; $N \leq 1$</p> <p>Accept:</p> <p>1. $D \leq 0.1\text{mm}$ Ignore</p> <p>2. $0.1\text{mm} \leq D \leq 0.2\text{mm}$; $N \leq 3$, min 5mm(1") apart</p> <p>3. $0.2\text{mm} \leq D \leq 0.3\text{mm}$; $N \leq 2$, min 5mm(1") apart</p> <p>4. $0.3\text{mm} \leq D \leq 0.4\text{mm}$; $N \leq 1$</p> <p>拒收: 超出以上规格</p> <p>Reject: Out of above spec</p> |
| <p>A 面 A area 包括正面视窗区、印刷区和背面视窗区</p> | <p>透光 light leakage</p> | <p>按照点缺陷, 最大-参照透光的限度样品 Follow the dot defect spec, MAX, Severity –see light leakage limit sample</p> |

| | | |
|--|--|---|
| Including view area/BM area of front surface and view area of rear surface | 崩角/崩边 Chipping on corner or edge | 允许: 1. $D \leq 0.1 \text{ mm}$ 不计, 2. $0.1 \text{ mm} \leq D \leq 0.5 \text{ mm}$; $N \leq 3$, 间距大于 5mm Accept: 1. $D \leq 0.1 \text{ mm}$ Ignore, 2. $0.1 \text{ mm} \leq D \leq 0.5 \text{ mm}$; $N \leq 2$, min 5mm(1") apart 拒收: 超出以上规格 Reject: Out of above spec |
| | 溢墨 Ink overflow | 30cm 可见不允许 Visual inspection 30cm not allowed |
| | 异色 Color discordant | 明显可见的印刷区颜色差异不允许 Obvious color difference in the BM area is not allowed |
| | Icon 背面印刷区刮伤 | Icon 背面印刷图案区不允许有穿透性刮伤 Icon printing logo area not allow penetrability scratch |
| | IR hole, light sensor hole LED hole |  1. A.B.C 孔, 需符合穿透率标准 A.B.C hole must be according the transmittancy 2. A.B.C 孔不允许透光, A.B 孔参照限度样本 light leakage is not allowed on A.B.C hole or follow the limited samples 3. A/B, C (LED) 孔不需在灯座下检查, 在黑色背景下检查无明显缺陷为 OK, |
| B 面 B area 正面台阶以外和背面印刷区 | 毛屑 Fiber 异物 Inclusion | 允许正面可视区看不到的缺陷 Accept when the defects can't be seen in the front View Area. |
| | 脏污 Stain 刮伤 Scratch | |
| | PC 板 PC sheet | |
| | 气泡 Bubble 棱边检查 Side check | |
| A 面 A area 包括正面视窗区、印刷区和背面视窗区 Including view area/BM area of front surface and view area of rear surface | 脏污 Dirty | 1. 不可擦拭的点状脏污按点状不良判定。 2. 可擦拭的脏物判定为 OK。 3. 保护膜的质量保证其为三个月, 在保证期内因保护膜问题引起的脏污判定为不良。 1. Dirty can not be cleaned follow the spec of dot. 2. Accept while the dirty can be cleaned. 3. The quality guarantee period of protective film is 3months, during the period, the spot or contamination is not allowed. |

| | | |
|---|---------------------------------|---|
| <p>A面 A area 包括正面视窗区、印刷区和背面视窗区 Including view area/BM area of front surface and view area of rear surface</p> | <p>LOGO 图案 LOGO Pattern</p> |  <p>Dot: according Dot spec 点: 按照点标准</p> <p>粗细不均: 用标准图文字宽与印刷图文字宽差值的绝对值相对于标准图文字宽的百分比来表示。</p> $\frac{ \text{标准图文字宽} - \text{丝印图文字宽} \times 100\%}{\text{标准图文字宽}} \leq 30\%$ <p>thickness odds: $\frac{ \text{Spec pattern width} - \text{Print pattern width} \times 100\%}{\text{Spec pattern width}} \leq 30\%$</p> <p>Drawing slant: Print pattern length ≤ 10mm, slant angle ≤ 3°; 10mm < Print pattern length ≤ 20mm, slant angle ≤ 1.5° 图文倾斜: 印刷图文长度 ≤ 10mm, 允许倾斜角度 ≤ 3°; 10mm < 印刷图文长度 ≤ 20mm, 允许倾斜角度 ≤ 1.5°</p>  <p>Pattern serration: H ≤ 0.05mm 图文锯齿: H ≤ 0.05mm</p> <p>Pattern leak print/ error/overprint, not allow. 图文漏印、错误、重印、断线: 不允许</p> <p>Pattern break line, width ≤ 0.10mm. 图文断线: 宽度 ≤ 0.10mm.</p> <p>Logo pattern color windage /color thin: Follow the limit samples. 字体和图案色差、色薄: 参照限度样板。</p> |
|---|---------------------------------|---|

9. Package 包装

| | | | |
|----------------------------------|-------------------------------|------------------|-----------------------|
| Product No. | MI0970CBP-C | Product name | TOUCH PANEL |
| Supplier | Multi-Inno Technology Co.,LTD | Recycle | () YES (√) NO |
| Quantity / each inner carton box | 10pcs | Material for box | (√) paper () plastic |

| | | | |
|-----------------------|--------------|--------------------|--------------------|
| Outer carton box size | 410*385*410 | Box type | (√) new () update |
| Quantity / outer box | 10×3= 30 pcs | Weight / outer box | 12Kg(Max) |

There are 1pcs TP in each plastic plate.

There are 10 pcs TP in each inner carton box.

There are 3 inner carton boxes in each outer carton box.

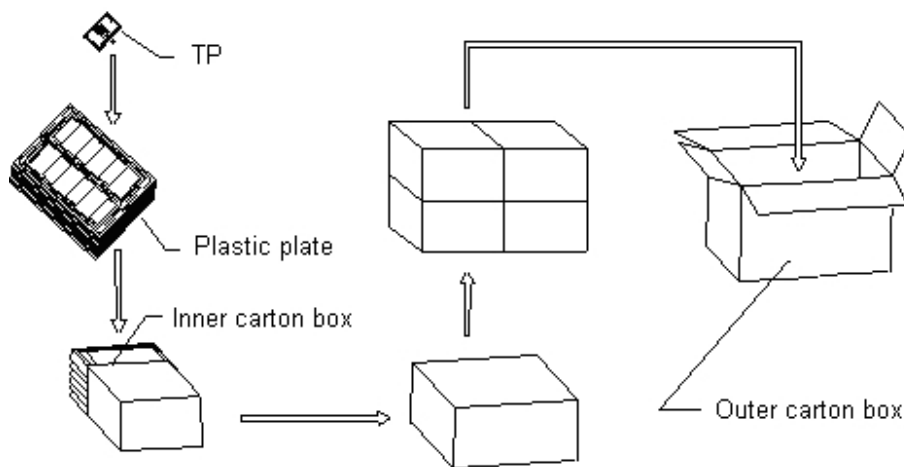

10. Application notes 使用注意事项

10-1 Please touch with the finger or electric pen when operating the capacitive touch panel.

操作电容式触摸屏时，请采用手指或导电性笔触摸。

10-2 Please note that dew gathering in the panel due to abrupt temperature or humidity change will cause deterioration of the performance.

请注意由于温度和湿度突然变化，而使触摸屏结露，这样可能会导致其性能下降。

10-3 Store the products at the temperature and humidity mentioned in the specification in a state of



package with carefully not to expose the products to the direct sunlight.

请把包装好的产品存放在规格书中规定的温度和湿度条件下，不要直接暴露于太阳光下。

10-4 Avoid stacking touch panels together in a heap. Avoid pressure on touch panel surface for long time. Otherwise, it may cause the product to be scratched and/or defective operation.

请不要将触摸屏堆叠存放，避免触摸屏表面长时间受压，以免造成刮花或者功能不良。

10-5 Do not hit the capacitive touch panel powerfully, or drop it from the heights, as it is made of glass.

由于电容式触摸屏是由玻璃所制，请勿强力撞击，或高处跌落。

10-6 Finger sacks, gloves and mask to protect the products from fingerprint of stain. Do not handle the touch panel by holding the FPC. Do not bend the FPC often or pull it hard when installing, as FPC is soft and connected to touch panel body.

请使用手指套，手套或者保护膜，保护产品不被指纹玷污。取放触摸屏时请勿拿 FPC。FPC 是柔软之物且连接在触摸屏上，安装时请勿经常性折弯或强力拉扯 FPC。

10-7 Do not contact the ink behind the touch panel with a hard object, to avoid scratches when installing.

安装时请勿用硬物接触电容式触摸屏背后的油墨，避免造成刮伤。

10-8 Avoid the touch panel or the firmware of the FPC contacting directly with the Metal, as they have conductivity. Avoid contacting with visual area when installing.

电容式触摸屏本身或 FPC 固件具有传导性，请避免与金属物质直接接触。安装时尽量避免接触可视区。

10-9 Pay Attention to high voltage and static electricity.

注意高压和静电。

10-10 Do not use alkaline detergent like glass cleaner, benzene or other organic solvents.

不要用碱性清洁剂，如玻璃清洗剂、苯或其它有机溶剂。

11. Storage condition and expiring time 保存条件和保质期

| | |
|--|--|
| 11-1 Storage temperature and humidity of warehouse 仓库存储温湿度 | 18~25℃, 40%RH~70%RH |
| 11-2 Expiring time 保质期 | <p>1. Surface appearance of storage is 3 months 放置后的表面脏污：保质期 3 个月。</p> <p>2. Except the first point, the other expiring time is 1 year. 除第 1 点外，保质期为 1 年。</p> <p>3. Beginning count time: According to the date of Touch Panel' date code. 开始计算日期：以 TP 上的 Date code 为开始计算日期。</p> |

Dear customer 诚挚的客户：

In order to guarantee the quality of the product that you purchase and our service quality, please sign in the first page in the thirty days after you have received this specification, and you can also write in the first page and send to us if you have any other special requirements. if we haven't received the information about the approval (include the spec, approval form, and others), we would think the customer accept the sample with acquiescence.

为了您所订购的产品品质得到更好的保证，并进一步方便我司后续作业，烦请贵司接到我司此份《规格书》后在 30 个工作日内无论确认与否，请给予回签。如对我司此规格之产品有特殊要求，烦请一并注明。如在 30 个工作日内没有收到贵司加签的相关信息(包括规格书、样品回头纸及其它相关确认信息)，我司将认为贵司对此款送样接受确认。