



**Display Future Ltd**

www.displayfuture.com

## **LCD MODULE SPECIFICATION**

**Model: DF-SSC0817---M2**

**This module uses ROHS materials**

### **For customer acceptance**

Customer		date
Approved		
Comments		

The standard product specification may change without prior notice in order to improve performance or quality. Please contact Display Future Ltd for updated specification and product status before design for the standard product or release of the order.

Revision	1.0
Engineering	
Date	2018/01/4
Our Reference	



# CONTENTS

- GENERAL SPECIFICATIONS
- PRODUCTION DESCRIPTION
- CIRCUIT BLOCK DIAGRAM
- PIN CONNECTIONS
- RELIABILITY
- SPECIFICATION OF QUALITY ASSURANCE
- PRECAUTIONS FOR USE OF CTP MODULES
- OUTLINE DRAWING

## ■ GENERAL SPECIFICATIONS

### 8” Capacitive multi-touch panel with USB interface

For information on the theory of operation, communications protocol, user interface guidelines, touch controller specifications, etc., refer to the following Solomon documentation:

---- SSD2533 Datasheet

Please contact Multi-Inno to request copies of these documents.

Features	Details	Unit	Note
Operation Technology	Projected capacitive	--	1
Product Structure	Glass Lens – Glass Sensor	--	2
Input Method	Bare fingers	--	--
Number of simultaneous touches	10 points multi-touch	--	--
Minimum Touch Area	Φ6	mm	--
Surface Treatment	--	--	--
Finger Pitch	18mm	mm	3
Connection Type	FPC, 4pin, Pitch0.5	--	—
Customer Application	Armairium	--	--
FG Weight	TBD	g	--
Surface Hardness	≥6H	--	--
Interface	USB	--	--

Note 1: Mutual mode.

Note 2: RoHS compatible.

Note 3: Two points in a distance of 18 mm or above shall be recognized as two separate points.

■ **PRODUCTION DESCRIPTION**

1 General description

Item	Contents	Unit	Note
Product Size	8	inch	--
Sensing Area	165.60 (W)×125.10(H)	mm	--
Sensor Glass Size	179.60(W) × 140.05(H)	mm	--
Sensor Glass Thickness	0.5	mm	--
Viewing Area(Cover Lens)	163.40(W)×122.90(H)	mm	--
Outer Dimension	208.80(W)×155.60(H)×1.75(D)	mm	--
Control IC	SSD2533QN10	--	--
Resolution	800×600	--	--
Interface	USB	--	--

2 Structure description

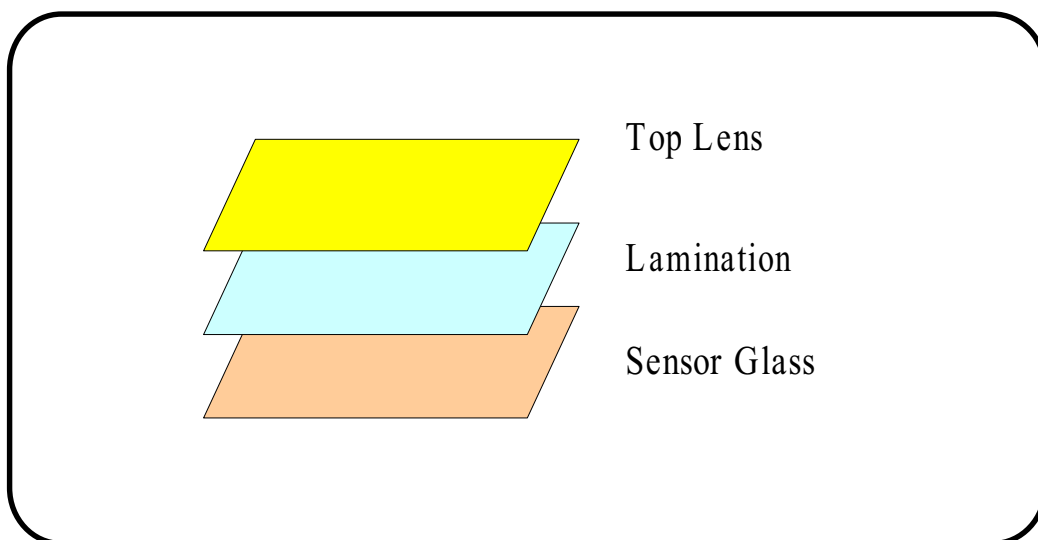

**Structure of touch panel**

### 3 DC Characteristics

(T<sub>A</sub>= 25°C,VDD=3.3V)

Item	Min	Typ	Max	Unit	Note
Power Supply Voltage	1.65	--	3.3	V	--
Active Mode	--	13	18	mA	Note 1
Sleep Mode	--	10	--	uA	--
Respond Time	--	--	16	ms	Note 2

Note 1: Active power varies based on a number of controllable parameters as well as the number of touches per second.

Note 2: When first finger touch on the TP, it is the time that TP report interruption to host from idle mode.

### 4 Interface Timing Chart

#### 4.1 Interface Timing

*Refer to SSD2533\_1.0 datasheet for details.*

#### 4.2 COMMAND DESCRIPTIONS

This chapter describes the standard solomon Capacitive Touch Panel products communication registers in address order for each device mode. Please contact Multi-Inno for more message.

##### Read Device ID Register (R02h)

R/W	Parameter	IB7	IB6	IB5	IB4	IB3	IB2	IB1	IB0
R	1	0	0	1	0	0	1	0	1
R	2	0	0	1	1	0	0	1	1
	POR	0	0	1	0	0	1	0	1
	POR	0	0	1	1	0	0	1	1

This register returned the Device ID "2533h".

##### Write Operation Mode (R25h)

R/W	Parameter	IB7	IB6	IB5	IB4	IB3	IB2	IB1	IB0
W	1	--	--	--	--	Op_Mode			
	POR	0	0	0	0	0	0	0	0

**Idle Mode** - In Idle Mode, no scanning activities will be performed. The analog block will be powered down always.

**Slow Scan Mode** - In Slow Scan Mode, the scan rate is dropped to 0~48HZ. This mode is suitable for mobile applications and GUI applications in most cases.

**Normal Scan Mode** - In Normal Scan Mode, the frame scan rate is 50 ~91 HZ. This mode is good enough for simple handwriting and gesture. This mode is also recommended for mobile application.

**Fast Scan Mode** - In Fast Scan Mode, the frame scan rate is 100~1000HZ. This mode can be for application like high speed sketching and detailed drawing.

**Read Operation Mode (R26h)**

R/W	Parameter	IB7	IB6	IB5	IB4	IB3	IB2	IB1	IB0
R	1	--	--	--	--	Op_Mode			
POR		0	0	0	0	0	0	0	0

To clarify the existing operation mode of SSD2533,user can read R\_Mode from register address R26h. The value of R\_OP\_Mode indicates the latest operation mode setting written by Operation Mode Setting Register.

**Touch Status (R79h)**

R/W	Parameter	IB7	IB6	IB5	IB4	IB3	IB2	IB1	IB0
R	1	--	--	F9	F8	F7	F6	F5	F4
R	21	F3	F2	F1	F0	AS	LO	OF	VF
POR		0	0	0	0	0	0	0	0

This register showed the status of the touch detection.When a touch event is detected,the IRQ signal will set to low and at least one bit on this register will set to "1" to indicate the touch status.This register is "0" if the IRQ signal is high.

Register	Name	Function
F9	Finger9 Detected	This bit will set to "1" indicating the present of 10 <sup>th</sup> finger
F8	Finger8 Detected	This bit will set to "1" indicating the present of 9 <sup>th</sup> finger
F7	Finger7 Detected	This bit will set to "1" indicating the present of 8 <sup>th</sup> finger
F6	Finger6 Detected	This bit will set to "1" indicating the present of 7 <sup>th</sup> finger
F5	Finger5 Detected	This bit will set to "1" indicating the present of 6 <sup>th</sup> finger
F4	Finger4 Detected	This bit will set to "1" indicating the present of 5 <sup>th</sup> finger
F3	Finger3 Detected	This bit will set to "1" indicating the present of 4 <sup>th</sup> finger
F2	Finger2 Detected	This bit will set to "1" indicating the present of 3 <sup>rd</sup> finger
F1	Finger1 Detected	This bit will set to "1" indicating the present of 2 <sup>nd</sup> finger
F0	Finger0 Detected	This bit will set to "1" indicating the present of 1 <sup>st</sup> finger
AS	Abnormal status	This bit will set to "1" when abnormal status detected
LO	Large Object	If a touch detected with touch area over Max Finger Area(R16h),this bit will set to "1"
OF	FIFO Overflow	This bit will set to "1" if Touch Event Stack has over 8 events stored
VF	FIFO Data valid	This bit will set to "1" if Touch Event Stack is valid data

**Finger01-10 (X,Y) coordinates,speed index and press weight index.(R7Ch - R85h)**

R/W	Parameter	IB7	IB6	IB5	IB4	IB3	IB2	IB1	IB0
R	1	x-coor[7:0]							
R	2	y-coor[7:0]							
R	3	x-coor[11:8]				y-coor[11:8]			
R	4	Weight index[3:0]				Speed index[3:0]			
POR	1	1	1	1	1	1	1	1	1
	2	1	1	1	1	1	1	1	1
	3	1	1	1	1	1	1	1	1
	4	0	0	0	0	0	0	0	0

SSD2533 can detect maximum of 10 fingers touch on the panel. The registers are used to report the x-y coordinate of the 10 fingers if present and only the most concurrent coordinates are reported.

The first touch point will put to R7Ch and the second touch point will put to R7Dh and so on. Once the finger number had been assigned, the system will keep tracking the same finger and update the latest x-y coordinate to same register until the finger leaving the touch screen.

**Event Stack (R86h)**

R/W	Parameter	IB7	IB6	IB5	IB4	IB3	IB2	IB1	IB0
R	1	Finger_Flag				Event_No			
R	2	x-coor[7:0]							
R	3	y-coor[7:0]							
R	4	x-coor[11:8]				y-coor[11:8]			
R	5	Weight index[3:0]				Speed index[3:0]			
POR	1	0	0	0	0	0	0	0	0
	2	1	1	1	1	1	1	1	1
	3	1	1	1	1	1	1	1	1
	4	1	1	1	1	1	1	1	1
	5	0	0	0	0	0	0	0	0

SSD2533 has a hardware interrupt line (IRQ) connected to the host processor. This interrupt line is active low and different kinds of events can activate this IRQ line. In any cases,at least one bit of the Touch Event Status Register(R79h) will be "1". If all bits of the Touch Event Status Register are "0", the IRQ line will return to its inactive state(high). The IRQ can be activating by 1,2 and 3 fingers only. The forth finger will not trigger any interrupt event.

**Event Stack Clear (R87h)**

This command is used for clear the event stack. If overflow occurred,the event stack cannot be cleared. Please read 0x79,0x86 and send 0x87.

**5 Mechanical Characteristics**

No.	Item	Requirement	Verification method
1	Surface Hardness	≥6H	JIS-K5600
2	Falling-ball Impact Test	No crack/scratch allowed after test	Use the 64g steel (Φ25) ball is dropped on the Glass surface from 70cm height at 1time(Glass side)
3	Surface Pressure Test	No crack/scratch allowed after test	15 Kgf pressure in the center of the display using a rubber test head with a diameter of 15mm,1 time,1 minute, non-operation
4	Terminal Pull Test	No visible and functional disturbances allowed after test	±90° direction, weight:500g, non-operation



## 6 Electrical Characteristics

(Ta=25°C, VDD=3.3V)

No.	Item	Specification	NOTE
1	Linearity	±1mm (Center Area)	±2mm (Border Area)
2	Veracity	±1 mm (Center Area)	±2mm (Border Area)
3	ESD	No visible and functional disturbances allowed after test	C=150pF、R=330Ω V=±8KV 5 times (Environment: 15°C~35°C、30%~60%,86Kpa~106Kpa)
4	Sensitivity	No disconnection	The diameter of test probes › Sensor Pitch (Note 1)

Note 1:Written using different diameter drawing a line on the touch screen to view the painting line whether there is a disconnection.

## 7 Optical Characteristics (Ta = 25 °C)

(Ta = 25°C)

No.	Item	Min.	Typ.	Max.	Unit	Remark
1	Transmission	86	--	--	%	Note 1
2	Reflectivity	--	--	4	%	Note 1,Note 2
3	Haze	--	--	--	%	--

Note1: 1) Measuring equipments: DMS-501, PR-705. @550nm,

2) Measuring condition:

①After stabilizing and leaving the panel alone at a given temperature for 30min, the measurement should be executed.

② Measuring surroundings: a stable, windless and dark room

③ Measuring temperature: Ta=25°C

④ 30 min after lighting the back-light

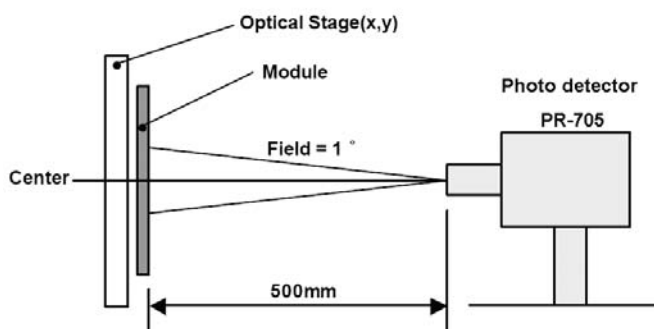

Note2: Conform to National standard GB2410—80 /ASTM D1003—61(1997)

**■ CIRCUIT BLOCK DIAGRAM**

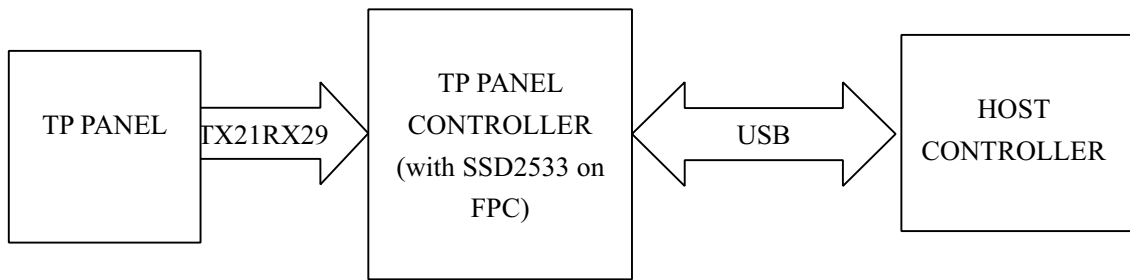

**System Block Diagram**

**■ PIN CONNECTIONS**

Pin No.	Symbol	Description	Remark
1	VDD	CTP power supply	--
2	D-	USB data- pin	--
3	D+	USB data+ pin	--
4	GND	Ground	--

**■ RELIABILITY**

No	Test Item	Test condition	Remark
1	High Temperature Storage	+80°C for 240hrs	Note1,Note2
2	Low Temperature Storage	-30°C for 240hrs	Note1,Note2
3	High Temperature Operation	+70°C for 240hrs	Note2
4	Low Temperature Operation	-20°C for 240hrs	Note2
5	High Temperature & Humidity Storage	+60°C 90%RH for 240hrs	Note1,Note2
6	Thermal Shock Test(Storage)	-30°C (30min) ↔ 80°C (30min) , Change Time:5min,20cycle	Note1,Note2
7	Drop Test(Package State)	Height:80cm, 1corner,3edges,6surfaces	Note2

Note1: Test samples are allowed a 2 hour recovery time at room temperature following non-operational tests before functional operation is verified.

Note 2: Additional test Item proposed by customer shall be determined by mutual agreement between customer and Multi-Inno

■ SPECIFICATION OF QUALITY ASSURANCE

1 Inspection condition

- a. Inspected Temperature: 20~25°C, Inspected Distance: 30±5cm.
- b. Viewing Angle:

When inspecting, keep the eyesight perpendicular to the product surface: 90± 30 degree, as below.

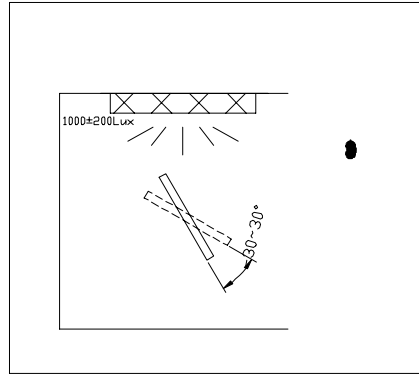

- c. Inspected illumination: 1000±200Lux.
- d. Inspected background: Under black background

2 Definiton for the appearance area.

A area: The front area of the sample and the transparent area from the backside; as below;

B area: The backside printing area. As below.

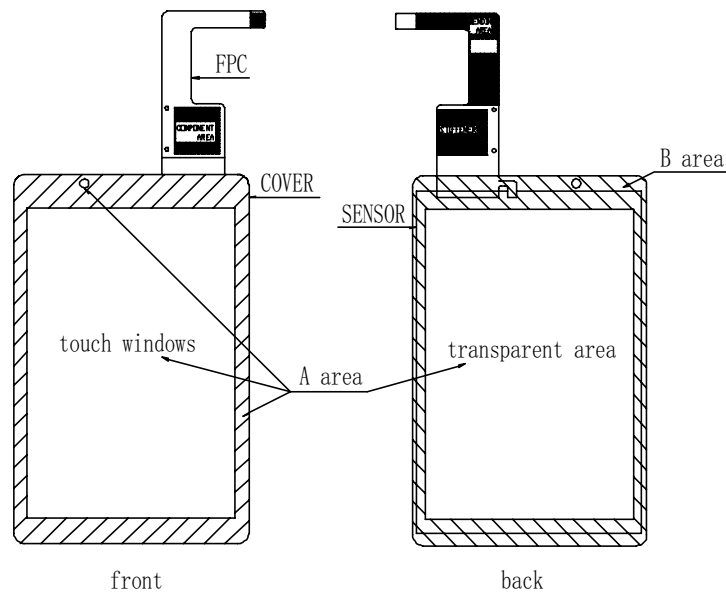

### 3 Definiton for the defects.

a. Circular Defects:

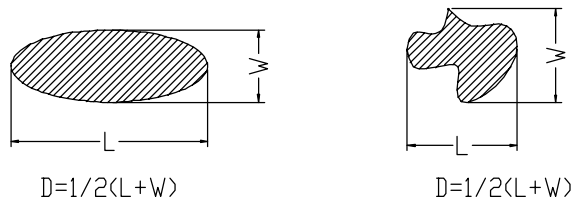

D: diameter W:width L: length (the same as below)

b. Linear Defects:

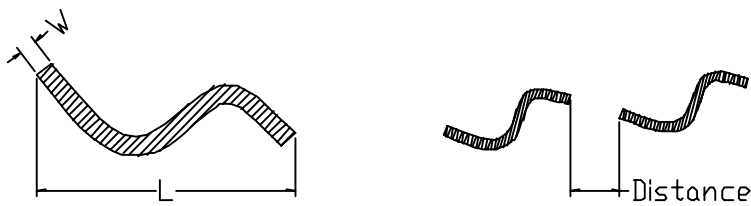

c. Pin hole(Translucidus)

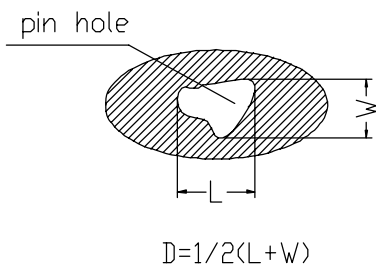

d. Zigzag for the printing ink

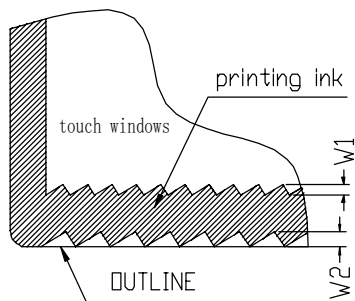

e. Edge Crack Chip

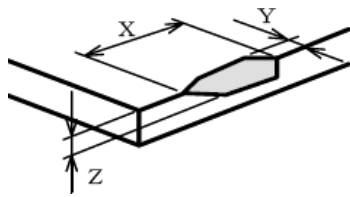

f. Corner Crack Chip

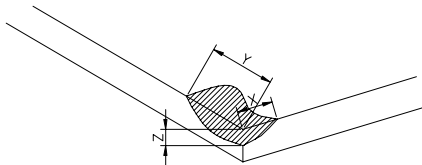

g. Bad Crack

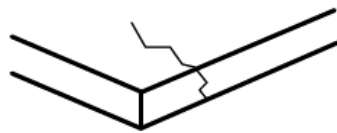

#### 4 Foreign object

No.	Inspection items	Judgment standard(Unit: mm)		
		Defect Size	Judgment (A Area)	Judgment (B Area)
1	Circular Defects(Dot, Impurity, Dust, Bubble)	$D \leq 0.20$	Neglected(distance $\geq 10$ )	Neglected
		$0.20 \leq D \leq 0.3$	$N \leq 5$ , (distance $\geq 10$ )	
		$D > 0.3$	Not allowed	
		Notes: 1、 The circular defects which can be removed is ignored. 2、 The circular defects of B area should not affect to assembly,functionality or final look of the product. 3、 The circular defects of A area does not include the protective film, TThe circular defects of B area does not include the adhesive tapes.		

2	Linear Defects(Scratch Line\Foreign material )	W(width)/L(length)		Judgment
		$W \leq 0.10, L \leq 3.0$		Neglected(distance $\geq 10$ )
		$0.10 < W \leq 0.20, L \leq 3.0$		$N \leq 3$ , (distance $\geq 10$ )
		$W > 0.2, L > 3.0$		Not allowed
		Notes: The foreign material which can be removed is ignored.		
3	Dent	Defect Size	Judgment (A Area)	Judgment (B Area)
		$D \leq 0.15$	Neglected(distance $\geq 10$ )	Neglected
		$0.15 \leq D \leq 0.3$	$N \leq 3$ , (distance $\geq 10$ )	
		$D > 0.3$	NG	
		Notes: 1、 The foreign material which can be removed is ignored. 2、 The foreign material of B area should not affect to assembly,functionality or final look of the product.		
4	Dirt/Fingerprint/Smokes/Snake/Rainbow effect	A area: not allowed; B area: neglected (Not affect to assembly,functionality or final look of the product.)		
5	Printing ink color	The printing ink color should be consistent with design drawing. (or client standard sample).		
6	Printing ink color difference	<p>1、 The judgement area is the front non-translucent zone of the sample.</p> <p>2、 Accept the same series ink color printing shift.</p> <p>3、 Color difference of IR hole,light sensor hole is not inspected.</p> <p>4、 If there is customer's inspection criteria or sample,determining by customer's inspection criteria or standard sample.</p>		
7	Transmittance-rate ( IR hole\light sensor hole)	Meet design drawing.		
8	Printing pin hole	Not allowed		
9	Font / Logo	Font / Logo should be printed smooth, no jagged, shadow, penetration, wear and tear, displacement,		

		disconnection and connection defects
10	Breakage on edge or corner	A area(front side): not allowed B area(back side): $X \leq 0.2, Y \leq 0.2, Z \leq 1/5T$ ; $N \leq 2$ , (distance $\geq 20$ ), Neglected
11	Crack	Not allowed
12	Printing ink Edges burrs / Printing ink Zigzag	1、 the front (back) printing ink edge of the touch window region : $W1 \leq 0.2$ , OK; $W1 > 0.2$ , NG。 2、 the front (back) printing ink edge of the sample: $W2 \leq 0.3$ , OK; $W2 > 0.3$ , NG。
13	Foreign material of printing area	(1).The touch windows + 0~2.0mm: the criteria is same to Circular Defects; (2). The touch windows + 2.0 ~ 5.0mm : $D \leq 0.3$ , Neglected(distance $\geq 5.0$ ) (3).The other areas: $D \leq 0.5$ , Neglected(distance $\geq 5.0$ )
14	Circular Defects for LED hole/ IR hole/sensor hole	Sensor hole、 LED hole: $D \leq 0.1\text{mm}$ , $N \leq 1$ , allowed ; $D > 0.1\text{mm}$ , not allowed; IR hole: $D \leq 0.1\text{mm}$ , neglected; $D > 0.1\text{mm}$ , not allowed。
15	Bad cutting section for cover/sensor	1.Cutting section allow the wave-like phenomenon, but the cutting edge level of view must be a smooth line; 2, cutting section does not allow any cracks appearance.
16	Surface Dirt	1, the process dirt which can not wipe with alcohol is not allowed; 2, The dirty can be wiped with a clean cloth or with clean cloth & alcohol , and the dirt is less than 10% of the total area of the product, and the dirt is less than two points each piece of product, allowed.
17	FPC	1.The component soldering can not be cold soldering, short, open circuit, burrs, tin ball; 2.The shape of FPC can not been broken, died off; 3.FPC stiffener of the component area can not drain back paste or damaged; 4.FPC version number should be consistent with the design drawing;
18	Tape (foam / double-sided adhesive, etc.) Judgement	Tape attached should be consistent with the design drawing;; not missing , unbreakable, non-attached side.

## ■ PRECAUTIONS FOR USE OF CTP MODULES

### 1 Mounting Precaution

#### 1.1 Beze Mounting

When mounting the CTP underneath a bezel, the CTP assembly should be mounted using a configuration that supports the back surface of the TFT module. The bezel edge must be positioned outside the active area of the CTP. A gap of 0.5mm to 1.0mm is needed between the bezel and the CTP surface. A foam gasket or similar material should be used to compensate for the tolerance of the enclosure, compression for the screw, etc.

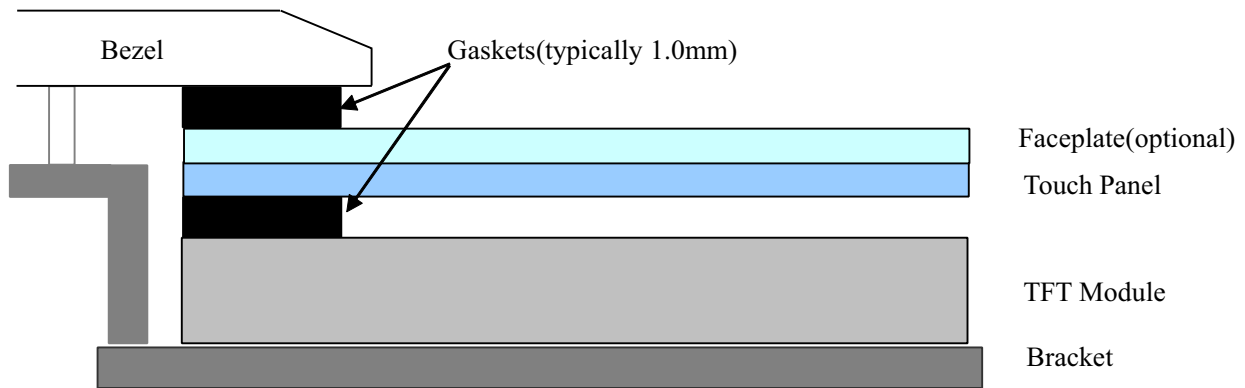

#### 1.2 Flush Mounting

When flush mounting the faceplate with the top of the enclosure, the enclosure must have a ledge for attaching the overhang of the faceplate as well as a ledge for supporting the back of the TFT module.

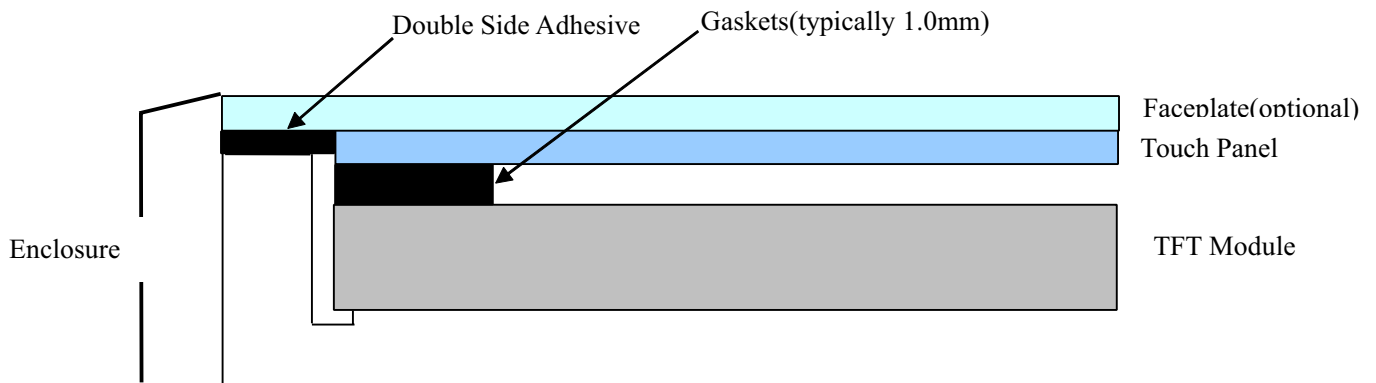



### 1.3 Optical Bonding

The airgap between the TFT and CTP can be eliminated by using an optical bonding. Elimination of the air gap improves the electrical performance of the CTP and enhances the clarity of the TFT image.

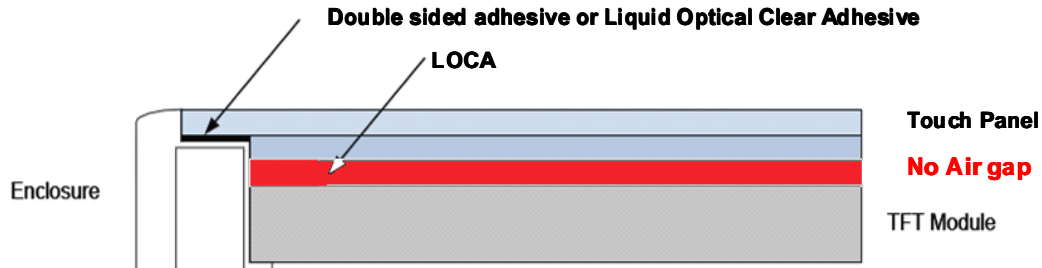

## 2 Handling Precautions

- 2.1 The product is made of glass. Do not subject it to a mechanical shock by dropping it from a high place, etc.
- 2.2 Do not apply excessive force to the product since this may damage to the performance;
- 2.3 If the display surface is contaminated, breathe on the surface and gently wipe it with a soft dry cloth. If still not completely clear, moisten cloth with one of the following solvents:
  - Isopropyl alcohol
  - Ethyl alcoholSolvents other than those mentioned above may damage the product. Especially, do not use the following:
  - Water
  - Ketone
  - Aromatic solvents
- 2.4 Do not attempt to disassemble the CTP Module.
- 2.5 If the logic circuit power is off, do not apply the input signals.
- 2.6 To prevent destruction of the elements by static electricity, be careful to maintain an optimum work environment.
  - a. Be sure to ground the body when handling the CTP Modules.
  - b. Tools required for assembly, such as soldering irons, must be properly ground.
  - c. To reduce the amount of static electricity generated, do not conduct assembly and other work under dry conditions.
  - d. The CTP Module is coated with a film to protect the display surface. Be care when peeling off this protective film since static electricity may be generated.

### 3 Storage precautions

- 3.1 When storing the CTP modules, avoid exposure to direct sunlight or to the light of fluorescent lamps.
- 3.2 The CTP modules should be stored under the storage temperature range. If the CTP modules will be stored for a long time, the recommend condition is:  
Temperature :  $0^{\circ}\text{C} \sim 40^{\circ}\text{C}$   
Relatively humidity:  $\leq 80\%$
- 3.3 The LCD modules should be stored in the room without acid, alkali and harmful gas.

### 4 notes

The CTP modules should be no falling and violent shocking during transportation, and also should avoid excessive press, water, damp and sunshine.

■ OUTLINE DRAWING

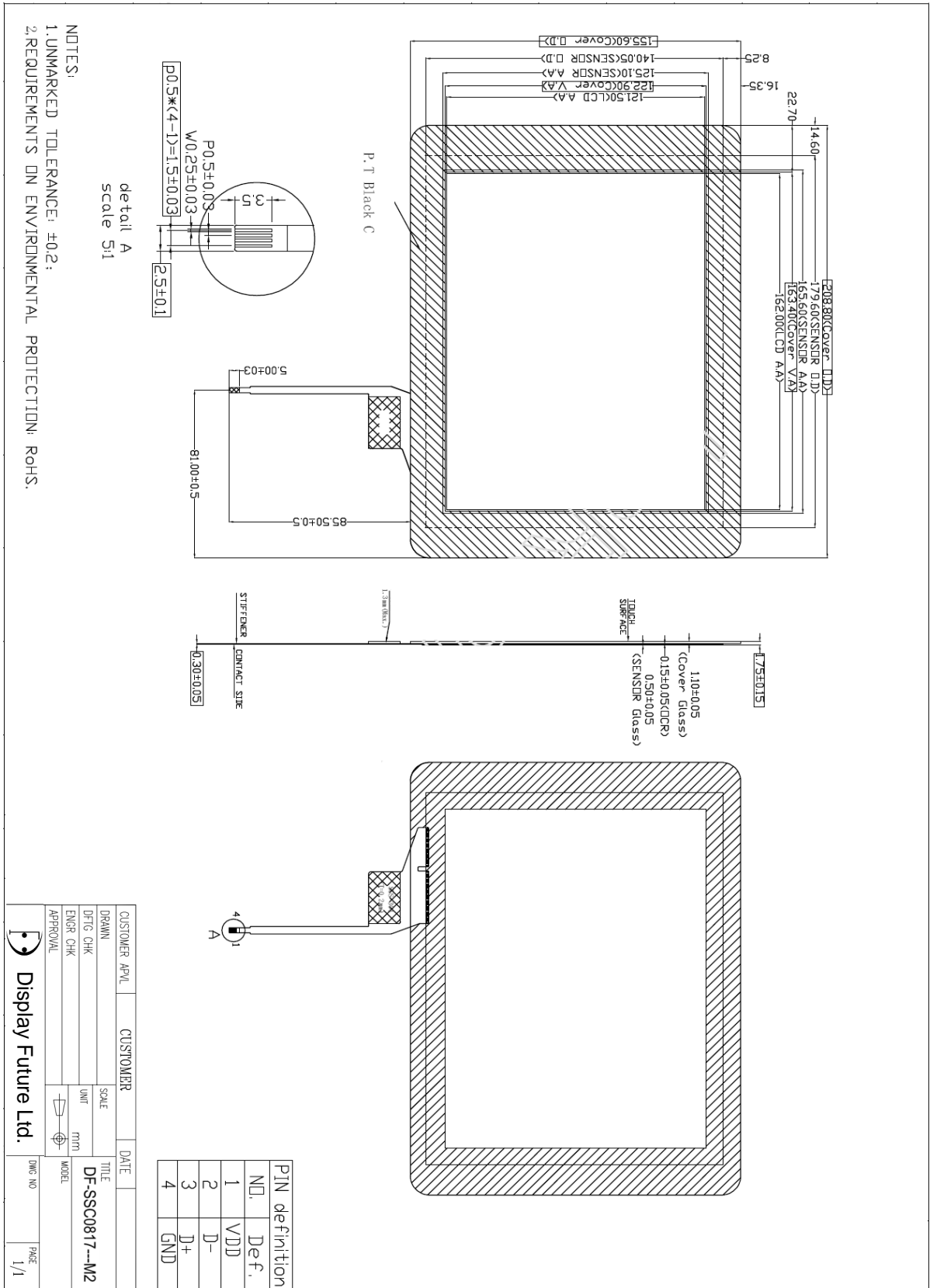

NOTES:  
 1. UNMARKED TOLERANCE: ±0.2;  
 2. REQUIREMENTS ON ENVIRONMENTAL PROTECTION: RoHS.

detail A  
 scale 5:1

CUSTOMER APPL	CUSTOMER	DATE	TITLE
DRAWN	SCALE		DF-SSC0817---M2
DFTG CHK	UNIT	mm	
ENGR CHK	MODEL		
APPROVAL			

Display Future Ltd.

DWG NO	PAGE
	1/1