



Display Future Ltd

www.displayfuture.com

LCD MODULE SPECIFICATION

Model: DF-SSC0699---M2

This module uses ROHS materials

For customer acceptance

Customer		date
Approved		
Comments		

The standard product specification may change without prior notice in order to improve performance or quality. Please contact Display Future Ltd for updated specification and product status before design for the standard product or release of the order.

Revision	1.0
Engineering	
Date	2018/01/4
Our Reference	

Table of Contents

1. COVER & CONTENTS	1
2. RECORD OF REVISION	2
3. APPLICATION	3
4. GENERAL SPECIFICATIONS	3
5. ABSOLUTE MAXIMUM RATINGS	3
6. ELECTRICAL CHARACTERISTICS	4
7. TIMING SPECIFICATIONS	4
8. PIN CONNECTIONS	15
9. BLOCK DIAGRAM	15
10. APPEARANCE SPECIFICATION	16
11. QUALITY ASSURANCE	20
12. PRECAUTIONS IN USE CTP	21
13. OUTLINE DRAWING	22

3. APPLICATION

UMPC, POS, MID

4. GENERAL SPECIFICATIONS

Composition: 7 inch Capacitive Touch Panel (CTP).

Interface: I²C for the CTP.

Item	Specification	Unit
Type	Transparent type projected capacitive touch panel	
Input mode	Human's finger	
Finger	5	
Outline Dimension	185.4(W) x 109.9(H) x 1.55(D)	mm
Sensor Active Area	154.6(W)(typ.) x 92.4(H)(typ.)	mm
Transparency	≥ 85%	%
Haze	≤ 1.0%	%
Hardness	3H (typ.) [by JIS K5400]	Pencil hardness
Weight	41.6	g
Point hitting life time	1,000,000 times min.	Note 1

Note 1: Use 8 mm diameter silicon rubber/force 3N to knock on the same point twice per second (no-operating), after test function check pass.

central point

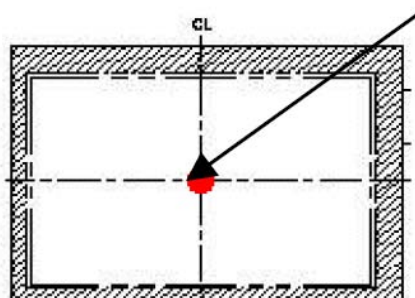

5. ABSOLUTE MAXIMUM RATINGS

Symbol	Description	Min	Typ	Max	Unit	Notes
VDD	Supply voltage	-0.3	-	3.6	V	
Vio	DC input voltage	-0.3	-	VDD+0.3	V	

6. ELECTRICAL CHARACTERISTICS

Symbol	Description	Fingers	F _{scan} (Hz)	Min	Typ	Max	Unit
VDD	Supply voltage			2.5	3.3	3.6	V
GND	Supply voltage			-	0	-	V
V _{IH}	Input H voltage			0.8VDD	-	VDD	V
V _{IL}	Input L voltage			0	-	0.2VDD	V
	System clock frequency					20	MHz
	CPU clock frequency					20	MHz
I	Active mode	1	280		-	4	mA
		2	160		-	5	mA
		3	90		-	5.2	mA
		4	80		-	5.4	mA
		5	75		-	5.6	mA
I _{sleep}	Sleep mode	0	10		-	0.11	mA
	Deep sleep mode	-			-	50	uA
I _{freeze}	Freeze mode	-			-	2	uA
	bootload	-			-	6.2	mA
	Calibration	-			-	6.2	mA

7. TIMING SPECIFICATIONS

7.1 CTP Interface and Data Format [Slave address is 0x5C (7 bit addressing)]

Communication protocol: I²C

Clock frequency: 100 KHz (400 KHz Fast mode)

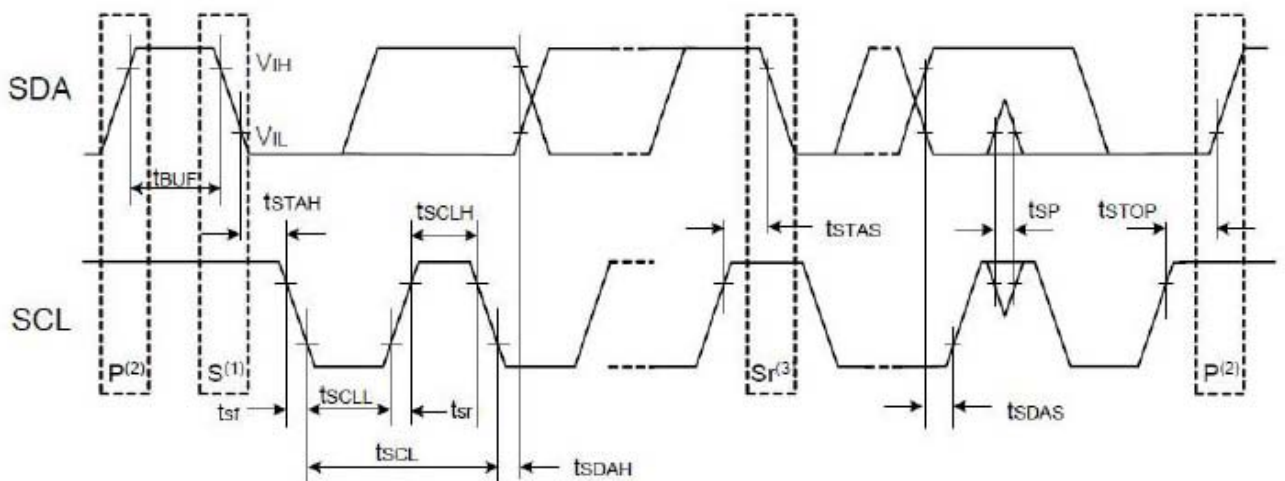

Note : (1) Start Condition ;(2)Stop Condition;(3)Retransmit start condition

Symbol	Description	Min	Max	Unit
tSCL	SCL input cycle time	12tcyc+600	-	ns
tSCLH	SCL input H width	3tcyc+300	-	
tSCLL	SCL input L width	5tcyc+500	-	
tsF	SCL, SDA input fall time		300	
tSP	SCL, SDA input spike pulse rejection time		1tcyc	
tsUF	SDA input bus-free time	5tcyc		
tSTAH	Start condition input hold time	3tcyc		
tSTAS	Retransmit start condition input setup time	3tcyc		
tSTOP	Stop condition input setup time	3tcyc		
tSDAS	Data input setup time	1tcyc+40		
tSDAH	Data Input hold time	10		

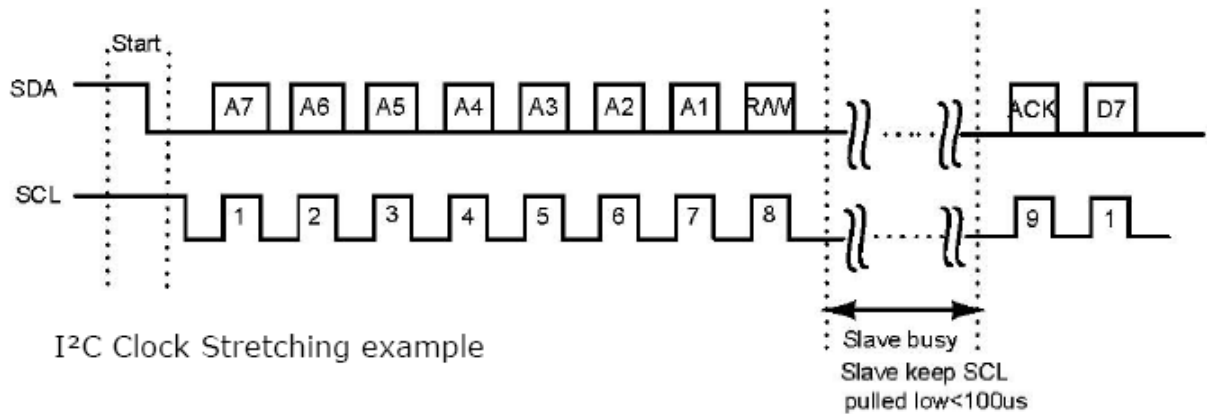

The protocol for data exchange has been designed with the following considerations

- 1 Most of the data traffic is read operation to get the finger or fingers position
- 2 Read operation do need an initial write operation.
- 3 Write operations are most of the time power management and interrupt setting instructions
- 4 Interrupt pulse width setting adjustments need a write operation.

S	START
P	STOP
A	Acknowledge
N	No acknowledge
W	WRITE
R	READ
DATA	8-bit

From slave to Master	From Master to Slave
----------------------	----------------------

7.2 Timing Characteristic

Read Operation

Read packets have variable content length, decided by the host. It is available to do a single read operation or a sequential read operation. Therefore, the beginning register address is need to set before a read operation. And the data sent exactly follow the register table 9, table 11, table 12, table 15. And, the firmware in the slave will use a memory copy of the register for I2C slave read operation, so that firmware can continue updates, and I2C slave is still using a consistent (but old) coordinates for read operation as below,

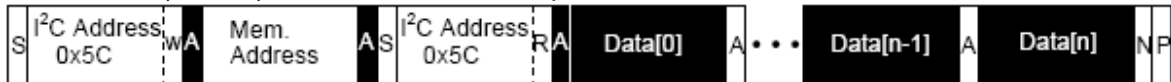

Read operation

In a sequential read operation, the first data sent by the MSI device is therefore the touching register, and then the X and Y coordinates of the first finger, then 2nd finger, 3rd finger, 4th finger and then coordinates of the 5th finger, and so on. Refer in below,



Coordinates read operation

If the host does not finish the read operation when the INT line is set again, the slave firmware will delay to update coordinates registers for I2C read operation until the host finish the read operation referred to below

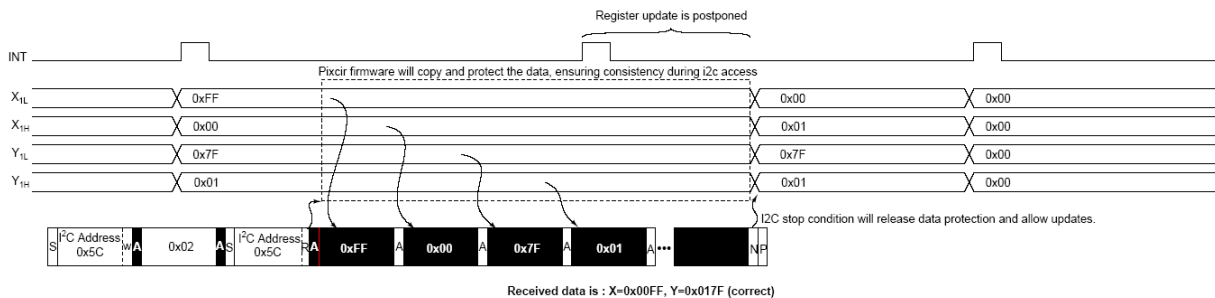

I2C stop condition will release data protection and allow the slave firmware update the coordinates registers for I2C read operation. So, the host has the change to give incorrect data when it gets the coordinates data with single read operation. Because the host sends many times for I2C stop condition in each multi-fingers coordinate's position reading, it will give the slave firmware chance to update the coordinates registers for I2C read operation, the host will give a combine unrelated data combines new and old coordinates together, referred to below

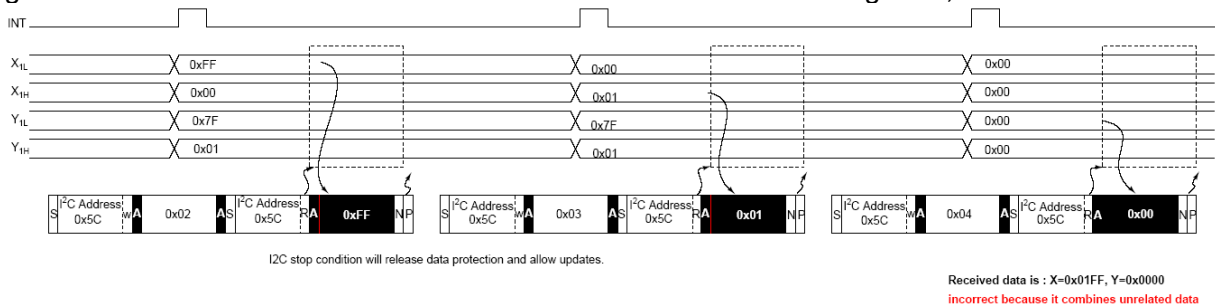

Coordinates read operation explanation

Write Operation

Write packets have variable content length, decided by the host. Write operation stops when host issues an I2C STOP symbol. The write packet is illustrated in Below. Following the I2C device address, the first byte of the write packet is always the destination register address, referred in table 9, table 11, table 12, table 15. Subsequent data values are written at the register pointed by the address, immediately upon reception of the byte. The address counter is automatically incremented. Subsequent data bytes are treated in continuation of the writing operation.

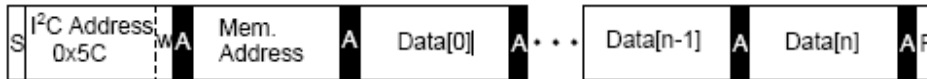

Write operation.

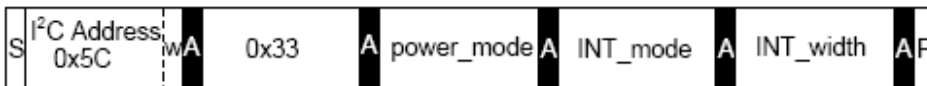

Write mode setting operation .

Note1: MSI Registers

Address	Type	Name	Description	Category
0	char	touching	Bitfield, see table 10	touch
1	char	buttons	Buttons bitfield	
2 (lsb) 3 (msb)	int	posx1	Finger #1 X position	
4 (lsb) 5 (msb)	int	posy1	Finger #1 Y position	
6	char	id1	Finger #1 identifier	
7 (lsb) 8 (msb)	int	posx2	Finger #2 X position	
9 (lsb) 10 (msb)	int	posy2	Finger #2 Y position	
11	char	id2	Finger #2 identifier	
12 (lsb) 13 (msb)	int	posx3	Finger #3 X position	
14 (lsb) 15 (msb)	int	posy3	Finger #3 Y position	
16	char	id3	Finger #3 identifier	
17 (lsb) 18 (msb)	int	posx4	Finger #4 X position	
19 (lsb) 20 (msb)	int	posy4	Finger #4 Y position	
21	char	id4	Finger #4 identifier	
22 (lsb) 23 (msb)	int	posx5	Finger #5 X position	
24 (lsb) 25 (msb)	int	posy5	Finger #5 Y position	
26	char	id5	Finger #5 identifier	
27	char	strength1	Finger #1 strength	
28	char	strength2	Finger #2 strength	
29	char	strength3	Finger #3 strength	
30	char	strength4	Finger #4 strength	
31	char	strength5	Finger #5 strength	

Bit 0,1,2	Nb of fingers touching (NBF)
Bit 3	Noise flag (indicates the report is unreliable) (NOI)
Bit 4	message flag (indicates a message string is sent by slave) (MSG)
Bit 5	buffer indicates the master has missed more than 2 reports, which are stored in buffer array (BUF)
Bit 6	palm flag (indicates the algorithm has a palm or similar blocking issue) (PAL)
Bit 7	water flag, indicates the algorithm has a rejected inputs due to water (WAT)

Address	Type	Name	Description	Category
32 (lsb) 33 (msb)	int	initial_distance	Distance separating fingers on the first time multitouch is detected	gesture
34 (lsb) 35 (msb)	int	distance	Distance separating fingers	
36 (lsb) 37 (msb)	int	ratio	100-distance / initial_distance	
38	char	water_level		monitor
39	char	noise_level		
40	char	palm_level		
41	char	signal_x		
42	char	signal_y		
43 50	char	button1 button8	Signal level of the buttons	buttons
51	char	power_mode	Power management register. See §2.2.3 and table 16	power management
52	char	INT_mode	Control of the ATTb pin, see §2.2.4 and table 17	
53	char	INT_width	ATTb pulse width	special operations
54-57	char		reserved for future use	
58	char	SPECOP	Special operation . See table 13	
59 (lsb) 60 (msb)	int	EEPROM_read_addr	Address used during special operation	
61	char	Engineering_cmd	Allows, with I ² c, to send "hyperterminal like commands" for engineering modes	version
62 (lsb) 63 (msb)	int	CRC	FLASH CRC value (must be requested by SPECOP), excluding "EEPROM" zone	
64-95	char	version[0..31]	Customer version control (32bytes) (imap to "eeprom")	

96-135	char	message[0..39]	Null terminated ASCII message string for engineering and debug purpose	
136 (lsb) 137 (msb)	int	RAW_CTRL	Controls RAW data mode (internal, raw, etc. . .) see table 14	
138	char	cross_x	X coordinate for method 1 crossing node measurement request	method 1
139	char	cross_y	Y coordinate for method 1 crossing node measurement request	
140 (lsb) 142 (msb)	int	cross_node	Measurement result for method 1	
142 (lsb) 143 (msb) 144 (lsb) 145 (msb) etc.	int int int	RAW[0..69] shared with history_buffer	Raw data, content controlled by RAW_CTRL register, or alternatively, history buffer (see below)	RAW data

0	Normal operation
1	"EEPROM" read operation, start address must be written in EEPROM_read_addr
2	"EEPROM" write operation NOT IMPLEMENTED
3	Calibration
4	CRC checksum of the application in Flash

Bit 0	Choose function (0: history buffer, 1: RAW data, 2: system info) See table 15
Bit 1	
Bit 2	Method (0 Or 1)
Bit 3	Show offset correction (and low-pass filter for M0)
Bit 4	Show m0 sensitivity adjustment (bit3 must also be set)
Bit 5	M1 pattern small (0) or pattern large (1)
Bit 6	M1 sense direction (0:Y,1:X)
Bit 7	M1 band scan. if 0, only report a single cross node. If 1,report a full X axis scan at RAW position
Bit 8	Disable Algorithm
Bit 9	Enable single shot RAW refresh, must be set to 1 and bit9 to 0. Auto back to 0 and bit9 to 1 after single shot is done
Bit 10	Refresh frozen after single shot is done when 1. Set to 0 to release the freeze and go back to normal refreshing
Bit 11	
Bit 12	
Bit 13	
Bit 14	
Bit 15	

Address	Type	Name	Description	Category
142	char	interval	Subsampling rate when filling the history buffer. Disable: 0. Keep all points: 1. Keep one out of two: 2. Etc.	history buffer
143	char	buffer_level	Number of fingers report in the buffer	
144 (lsb) 145 (msb)	int	posx	Coordinate X of the reported point, at time=0	
146 (lsb) 147 (msb)	int	posy	Coordinate Y of the reported point, at time=0	
148 (lsb) 149 (msb)	int	posx	Coordinate X of the reported point at time=1	
150 (lsb) 151 (msb)	int	posy	Coordinate Y of the reported point at time=1	
...				
298 (lsb) 299 (msb)	int	posx	Coordinate X of the reported point, at time=19	
300 (lsb) 301 (msb)	int	posy	Coordinate Y of the reported point, at time=19	

7.3 Operating Mode Register

7.3.1 POWER_MODE Register

Address	Name	Description of POWER_MODE Register
7-4	IDLE_PERIOD[3-0]	Refer to ALLOW_SLEEP function description Idle_period_time = k * 16 * Active_scan_period_time [s], with k = value of IDLE_PERIOD[3-0] Active_scan_period_time = duration [s] of a scan period in active mode.
3	-	Not used
2	ALLOW_SLEEP	Allow self demotion from active to sleep mode, provide that this flag is set. If the MSI device is in active mode and no fingers is detected for more than IDLE_PERIOD time, then it allow AUTO JUMP to sleep mode. If this flag is not set, the host must explicitly switch the device from active to sleep mode.
1-0	POWER_MODE[1-0]	Power mode setting of the MSI device: 00:Active Mode 01:Sleep Mode 10:Deep Sleep Mode 11:Freeze Mode

7.3.2 INT_MODE Register

Address	Name	Description
7-4	-	Not used
3	EN_INT	0:disable interrupt mode 1:enable interrupt mode
2	INT_POL	0:the interrupt is low active(default) 1:the interrupt is high active
1-0	INT_MODE[1-0]	00:INT assert periodically 01:INT assert only when finger moving 10:INT assert only when finger touch(default)

7.3.3 Power management

Active mode

In this mode, the slave resumes with a new scan directly after each I²C transfer (after INT rising edge). This is used to reach the highest refresh rate, but also has the highest current consumption. Below shows how to force the slave into Active mode.

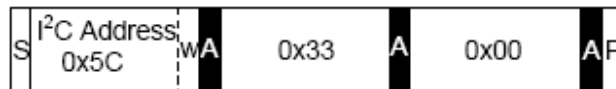

Active mode sequence

Sleep mode

This mode is selected to decrease the current consumption during low activity phases on the sensor, which need a lower refresh rate(10Hz). The MSI can automatically switch to Active mode(when finger is detected, provided that ALLOW_SLEEP bit is set in the POWER_MODE register) or by set POWER_MODE register. Also, the MSI can automatically switch from Active to Sleep mode when no finger is detected for more than IDLE_PERIOD time, provided that ALLOW_SLEEP bit is set in the POWER_MODE register. Figure 44 shows how to force the slave into Sleep mode. Below shows how to force the slave into Sleep mode can automatically switch, provided IDLE_PERIOD=10.

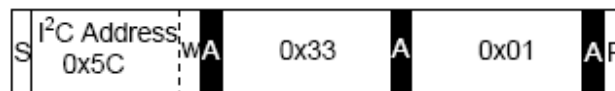

Sleep mode sequence

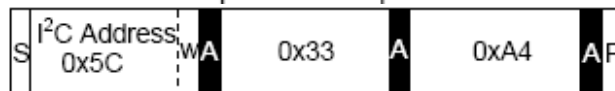

Sleep mode automatically switch sequence

Deep Sleep mode

This mode is selected to achieve the minimum consumption during very low activity phases on the sensor, which need a lowest refresh rate (1Hz). The MSI only can switch to Deep Sleep mode by set POWER_MODE register. Below shows how to force the slave into Deep Sleep mode.

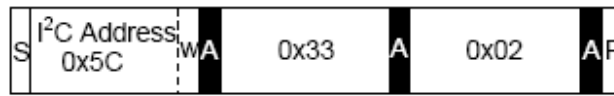

Deep Sleep mode sequence

Freeze mode

In this mode, the slave MCU internal clock source is stopped, and consumption is only MOS leakage. Below shows how to force the slave into Freeze mode. There are two ways to wake up from freeze mode.

- RST pin pull down (connect to the Ground) (default)
- INT pin change (“1 to 0” or “0 to 1”)

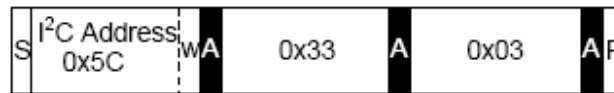

Freeze mode sequence

7.3.4 Transition of INT line

When INT_MODE=00 in the INT MODE register, the slave will set the INT line with INT_width pulse width after each scan in order to request the attention from the host, as shown in below

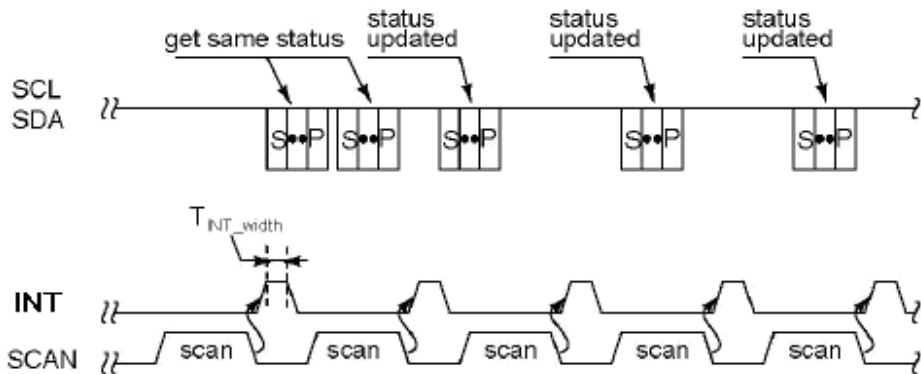

INT line pull up by slave (INT_POL=1, INT_MODE=00 in the INT mode register)

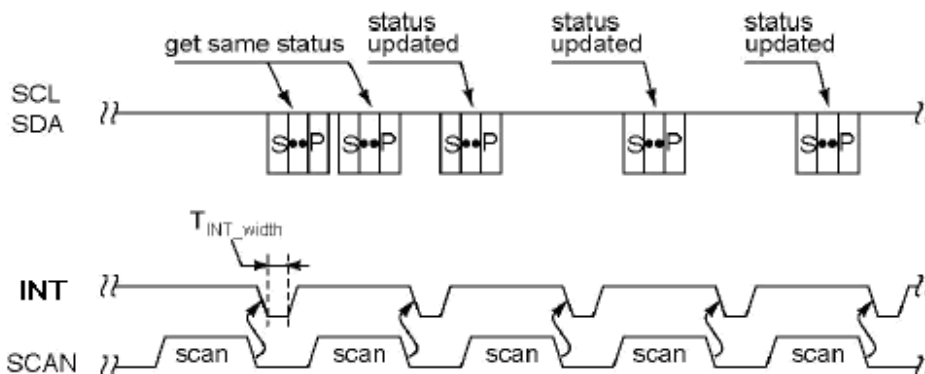

INT line pull down by slave (INT_POL=0, INT_MODE=00 in the INT mode register)

When INT_Mode=01 in the INT mode register and finger moving on the panel, the slave will set The INT line after each scan, as shown in below.

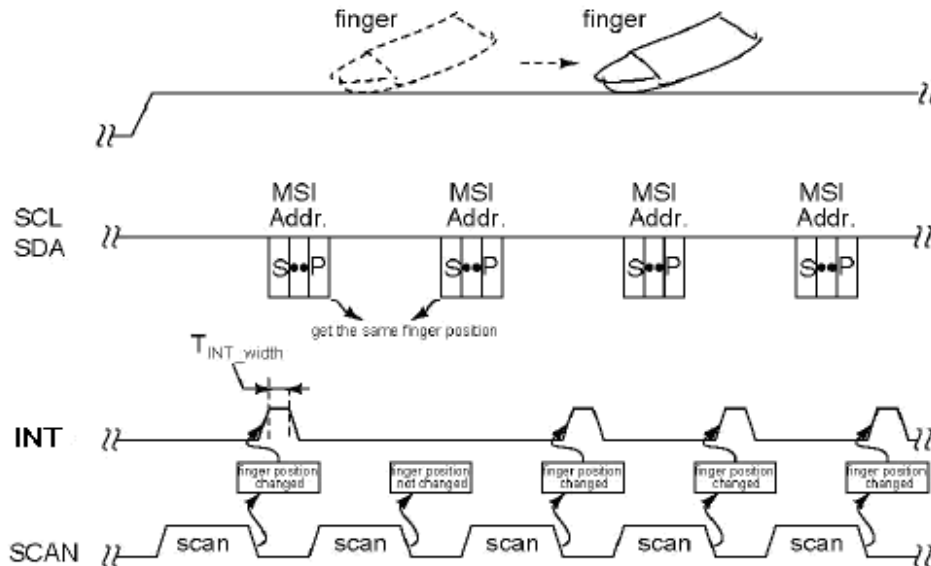

INT line pull up when finger moving (INT_POL=1, INT_MODE=01 in the INT mode register)

When fingers leaves the panel, the slave will continue to pulse INT line for each scan; but once the master has serviced this request and become now aware that there is no more finger touching, the slave will stop pulse the INT line, and will also gradually reduce the scan speed, as shown in below

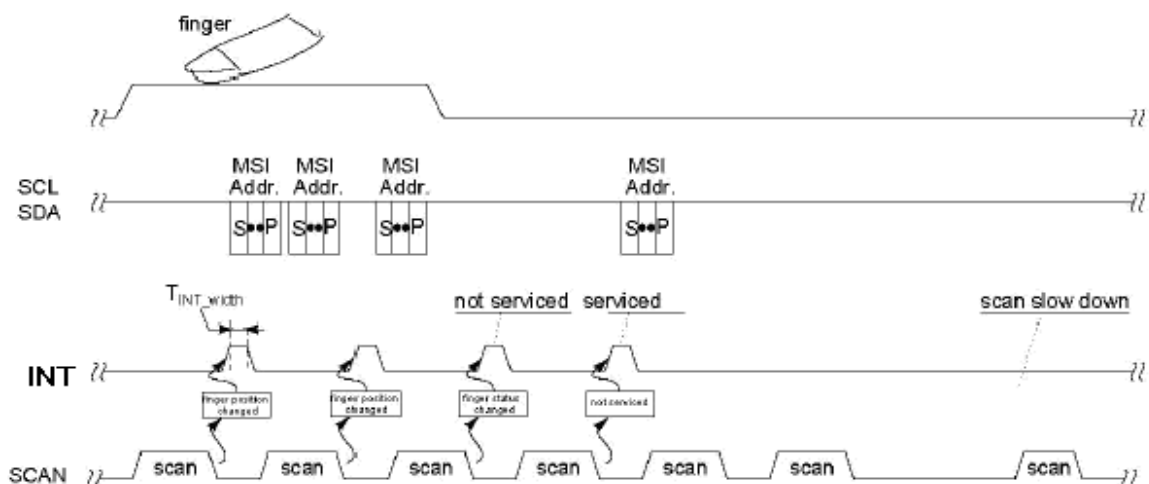

INT line will stop pulse when finger leaves and master has acknowledge the situation (INT_POL=1 in the INT mode register)

When INT_Mode=10 in the INT mode register and finger touch the panel, the slave will set The INT line after each scan as shown in below.

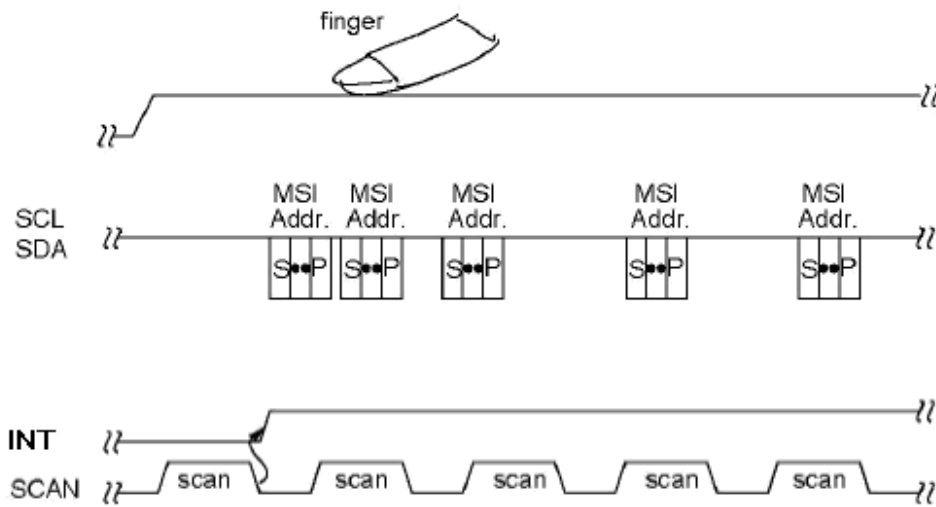

INT line pull up when finger touch (INT_POL=1, INT_MODE=10 in the INT mode register)

When fingers leaves the panel, the slave will continue keep INT line status for each scan; but once the master has serviced this request and become now aware that there is no more finger touching, the slave will release the INT line, and will also gradually reduce the scan speed, as shown in below

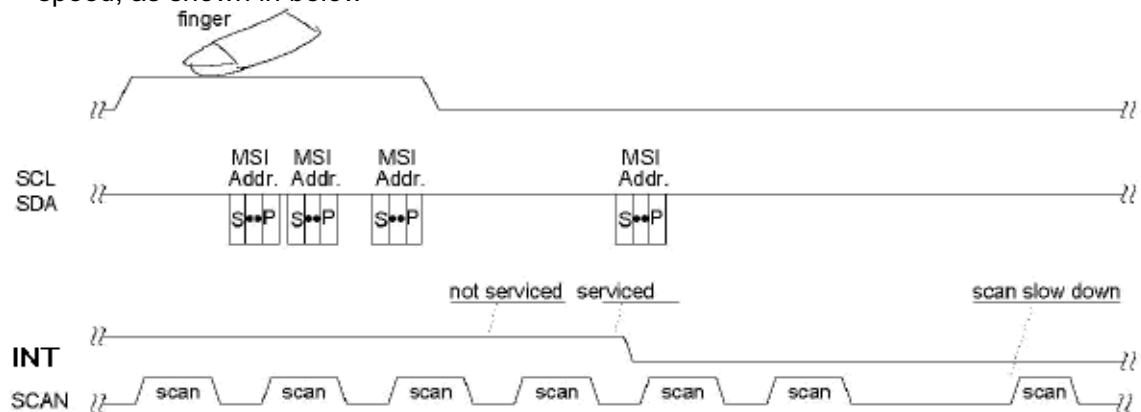

INT line will stop pulse when finger leaves and master has acknowledge the situation (INT_POL=1 in the INT mode register)

8. PIN CONNECTIONS

No.	Name	I/O	Description
1	SDA	I/O	Serial data access
2	SCL	I	Clock; 100KHz
3	RST	I	Reset
4	INT	O	Active low when data output from touch panel
5	VDD	-	Power; VDD=3.3V(typ.)
6	GND	-	Ground

9. BLOCK DIAGRAM

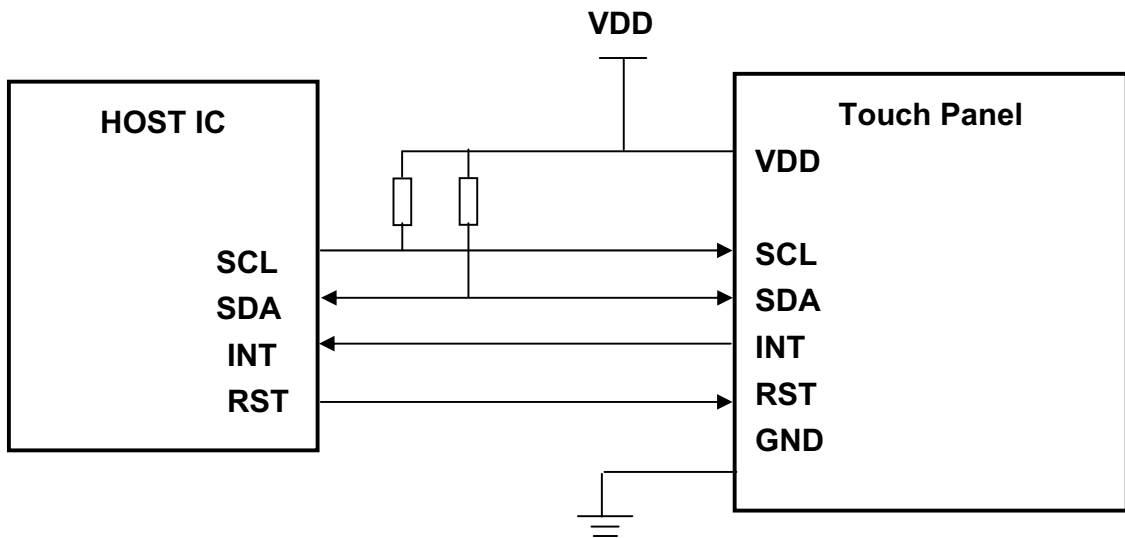

Note : 1. USE APPROPRIATE RESISTOR VALUE DURING HIGH SPEED SCL CLOCK.

SUGGESTION : RESISTOR RECOMMENDATION : 1K ohm.

2. To reduce the noise from the power, we suggest you use the independent power for the touch panel (VDD)

10. Appearance Specification

10.1 Process/Content:

10.1.1 Inspection equipment : fluorescent lamp , functional test jig , magnifying glass, Vernier caliper, ESD wrist strap.

10.1.2 Environment demand

1.2.1 Temperature : $25\pm 5^{\circ}\text{C}$

1.2.2 Humidity : 30-75%RH

1.2.3 Luminance : Fluorescent light (appearance : 800-1200UXL function : 100-500UXL)

10.1.3 Inspection process

1.3.1 Inspect distribution operation

1.3.2 Shift team leader is in charge of distributing work when work order goes to OQC inspection of finished products

1.3.3 Products of great emergency or especially asked by customer should be finished in advance.

1.3.4 All the items should be fully inspected before shipment.

1.3.5 The inspection standard & specification should be carried out according to customer's demand. If customer has no other standard & specification, just stick to this one.

10.1.4 Sampling plan

1.4.1 Do tests regularly according to MIL-STD-105E. Single sampling plan is arrived out according to Level II .

1.4.2 Defect definition

1.4.2.1 Major defect is inspected according to AQL 0.65%.

1.4.2.2 Minor defect is inspected according to AQL 1.0%.

10.1.5 Appearance inspection

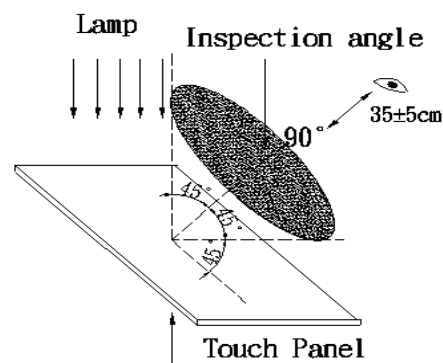

1.5.1 Appearance inspection method

Inspection angle spacing : 30-40cm

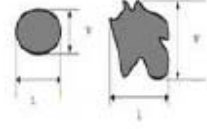
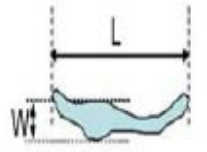

1.5.2 Appearance inspection standard

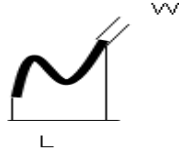
Item	Spec		Statement
Foreign material Punctiform	Spec	Q' ty allowed	 <p>$D = (L + W) / 2$</p>
	D > 0.8mm	0	
	0.3mm ≤ D ≤ 0.8mm	5	
	D < 0.3mm	Disregarded	
Foreign material Linear	Spec	Q' ty allowed	 <p>L : Long W : Width</p>
	W > 0.1mm L > 10mm	0	
	0.05mm ≤ W ≤ 0.1mm L ≤ 10mm	5	
	W < 0.05mm	Disregarded	
Image uniformity	Gray color can be seen on RGB through ND5%		

TP scratch	Spec	Q' ty allowed	
	W > 0.1mm L > 10mm	0	
	W ≤ 0.1mm L ≤ 10mm	5	
TP dented spot	Spec	Q' ty allowed	 <p>$D = (L + W) / 2$</p>
	D > 0.8mm	0	
	0.3mm ≤ D ≤ 0.8mm	5	
TP overflows or lacks of glue	±0.45mm		

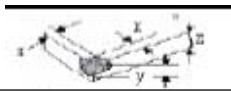
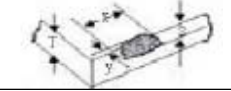
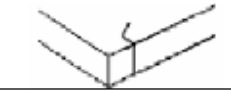
Surface broken	$X < 2\text{mm}$ $Y < 2\text{mm}$ $Z < \text{glass}$	
Edge broken	$X < 2\text{mm}$ $Y < 2\text{mm}$ $Z < \text{glass}$	
Rift	Not allowed	
Bubble appears in protection film	$D > 10\text{mm}$ $N = 0$ $5 \leq D \leq 10\text{mm}$ $N = 2$ $D < 5$ disregarded	
TP deviation	According to the specifications of customer's drawing	
Bubble	$D \leq 0.3\text{mm}$ disregarded $0.3\text{mm} < D \leq 0.5\text{mm}$ $N \leq 3$ $0.3\text{mm} < D$ not allowed No influence on appearance and function in invisible area OK	
Printing ink	No light leak Silk-screen saw tooth : $S \leq 0.1$ disregarded $0.1\text{mm} \leq S \leq 0.15\text{mm}$ $N = 5$ $S > 0.15$ ng LOGO break line NG Script dim, printed backwards, no printing in wrong place	
Finger print	Not allowed	
Stain	Stain on surface can be removed OK Bonding surface has no influence on appearance and function OK Can't be removed & not allowed	
Protection film	Bent isn't allowed No lift up Bent is allowed $L < 10\text{MM}$ $N \leq 5$	

11. QUALITY ASSURANCE

11.1 Test Condition

11.1.1 Temperature and Humidity(Ambient Temperature)

Temperature : 25 ± 5°C

Humidity : 65 ± 5%

11.1.2 Operation

Unless specified otherwise, test will be conducted under function state.

11.1.3 Container

Unless specified otherwise, vibration test will be conducted to the product itself without putting it in a container.

11.1.4 Test Frequency

In case of related to deterioration such as shock test. It will be conducted only once.

11.1.5 Test Method

Reliability Test Item & Level		Test Level
No.	Test Item	
1.	High Temperature Storage Test	T= 70°C, 120hrs after 1 hrs at room temperature and test.
2.	Low Temperature Storage Test	T= -20°C, 120hrs after 1 hrs at room temperature and test.
3.	High Temperature and High Humidity Storage Test	T= 40°C, 90%RH,120hrs after 24 hrs at room temperature and test.
4.	Thermal Cycling Test (No operation)	-20 °C 30min ~ 70 °C 30 min , 100 Cycles after 24 hrs at room temperature and test.
5.	Vibration Test (No operation)	Frequency :10 ~ 55 HZ Amplitude :1.5 mm Sweep time : 11 mins Test Period: 6 Cycles for each direction of X, Y, Z
6.	ESD TEST	Air Discharge : ±8KV Indirect Contact Discharge : ±4KV

12. PRECAUTIONS IN USE CTP

1. ASSEMBLY PRECAUTIONS

- (1) Since Touch Panel is consist of glass, please be careful your hands to be injured during handing. You must wear gloves during handing.
- (2) Do not touch, push or rub the exposed touch panel, tweezers or anything harder than HB pencil lead. And please do not rub with dust clothes with chemical treatment.
- (3) Do not stack the touch panels together. Do not put heavy objects on touch panel.
- (4) Please do not take a CTP to pieces and reconstruct it. Resolving and reconstructing modules may cause them not to work well.
- (5) Please excessive force or strain to the panel or tail is prohibited, Do not lift touch panel by cable(FPC).
- (6) Use clean sacks or glove to prevent fingerprints and/or stains left on the panel. Extra attention and carefulness should be taken while handling the glass edge.
- (7) Please pay attention for the matters stated below at mounting design of touch panel enclosure.
Enclosure support to fix touch panel must be out of active area.(do not design enclosure presses the active area to protect from miss put)

2. OPERATING PRECAUTIONS

- (1) Please be sure to turn off the power supply before connecting and disconnecting signal input cable.
- (2) Please do not change variable resistance settings in CTP. They are adjusted to the most suitable value. If they are changed, it might happen CTP does not satisfy the characteristics specification
- (3) Be careful for condensation at sudden temperature change. Condensation makes damage to sensor or electrical contacted parts.
- (4) CTP has high frequency circuits. Sufficient suppression to the electromagnetic interference shall be done by system manufacturers. Grounding and shielding methods may be important to minimize the interference.
- (5) Touch the panel with your finger or stylus only to assure normal operation. Any sharp edged or hard objects are prohibited.
- (6) Operate the panel in a steady environment. Abrupt variation on temperature and humidity may cause malfunction of the panel.

3. ELECTROSTATIC DISCHARGE CONTROL

- (1) The operator should be grounded whenever he/she comes into contact with the CTP. Never touch any of the conductive parts such the copper leads on the FPC and the interface terminals with any parts of the human body.

- (2) The CTP should be kept in antistatic bags or other containers resistant to static for storage.
- (3) Only properly grounded soldering irons should be used.
- (4) If an electric screwdriver is used, it should be well grounded and shielded from commentator sparks.
- (5) The normal static prevention measures should be observed for work clothes and working benches; for the latter conductive (rubber) mat is recommended
- (6) Since dry air is inductive to statics, a relative humidity of 50-60% is recommended.

5. STORAGE PRECAUTIONS

- (1) When you store touch panel for a long time, it is recommended to keep the temperature between 0°C-40°C without the exposure of sunlight and to keep the humidity less than 90%RH.
- (2) Please do not leave touch panel in the environment of high humidity and high temperature such as 60°C 90%RH
- (3) Please do not leave touch panel in the environment of low temperature; below -20°C.

6. OTHERS

For the packaging box, please pay attention to the followings:

- a. Please do not pile them up more than 5 boxes. (They are not designed so.) And please do not turn over.
- b. Please handle packaging box with care not to give them sudden shock and vibrations. And also please do not throw them up.
- c. Packing box and inner case for CTP are made of cardboard. So please pay attention not to get them wet. (Such like keeping them in high humidity or wet place can occur getting them wet.)

7. LIMITED WARRANTY

Unless otherwise agreed between Display Future and customer, Display Future will replace or repair any of its CTP which is found to be defective electrically and visually when inspected in accordance with Display Future acceptance standards, for a period on one year from date of shipment. Confirmation of such date shall be based on freight documents. The warranty liability of Display Future is limited to repair and/or replacement on the terms set forth above. Display Future will not responsible for any subsequent or consequential events.

13. OUTLINE DRAWING

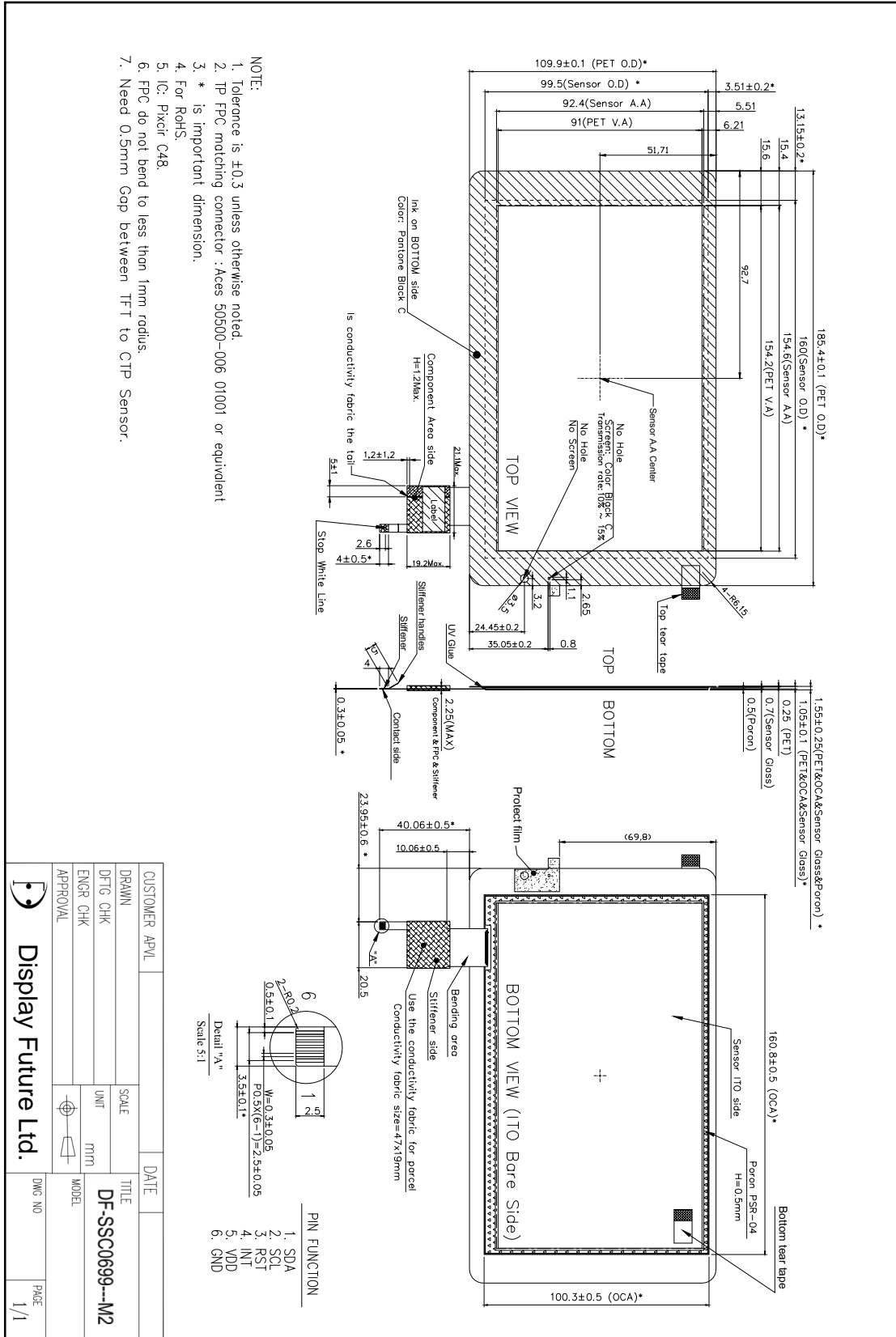

CUSTOMER APVL	DATE
DRAWN	SCALE
DFTG CHK	UNIT
ENGR CHK	MM
APPROVAL	MODEL
Display Future Ltd.	
DWG NO	PAGE
	1/1