

HTM320240A

LCD Module User Manual

Shenzhen HOT Display Technology Co., Ltd.

Rev.	Descriptions	Date
01	Prelimiay Release	2008-11-04

Table of Content

1. Basic Specifications.....	3
1.1 Display Specifications.....	3
1.2 Mechanical Specifications.....	3
1.3 Circuit Diagram.....	3
1.4 Interface Description.....	4
(1) CON1 接口定义.....	4
(2) CON2 接口定义.....	5
(3) CON3 接口定义.....	6
2. Absolute Maximum Ratings.....	7
3. Electrical Characteristics.....	7
3.1 DC Characteristics.....	7
3.2 LED Backlight Circuit.....	7
3.3 AC Characteristics.....	8
3.4 Reset Timing.....	11
4. Function specifications.....	12
4.1 Adjusting the display contrast.....	12
4.2 Resetting the LCD module	12
4.3 Interfacing setting.....	12
4.4 Display Pixel Map.....	13
4.5 Display Commands.....	13
4.6 Basic Operating Sequence.....	13
5. Inspection Standards.....	14
6. Handling Precautions.....	15
6.1 Mounting method.....	15
6.2 Cautions of LCD handling and cleaning.....	15
6.3 Caution against static charge.....	15
6.4 Packaging.....	15
6.5 Caution for operation.....	15
6.6 Storage.....	15
6.7 Safety.....	15

1. Basic Specifications

1.1 Display Specifications

- 1>LCD Display Mode : STN, Negative(OR Positive), Transmissive
- 2>Viewing Angle : 6H
- 3>Driving Method : 1/240 Duty, 1/16 Bias, $V_o=24.0V$
- 4>Operation Voltage : 5.0V(OR 3.3V)
- 5>Backlight : White LED Backlight

1.2 Mechanical Specifications

- 1>Outline Dimension : 160.0 x 109.0 x 13.5mm (See attached Outline Drawing for Details)

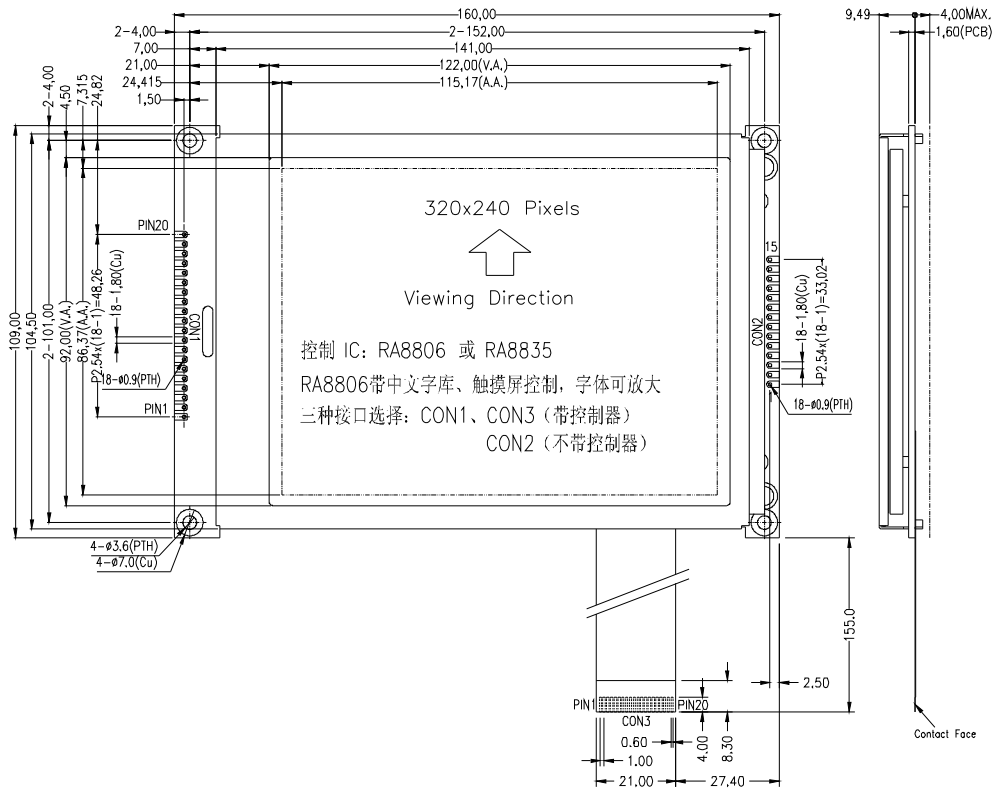

1.3 Circuit Diagram

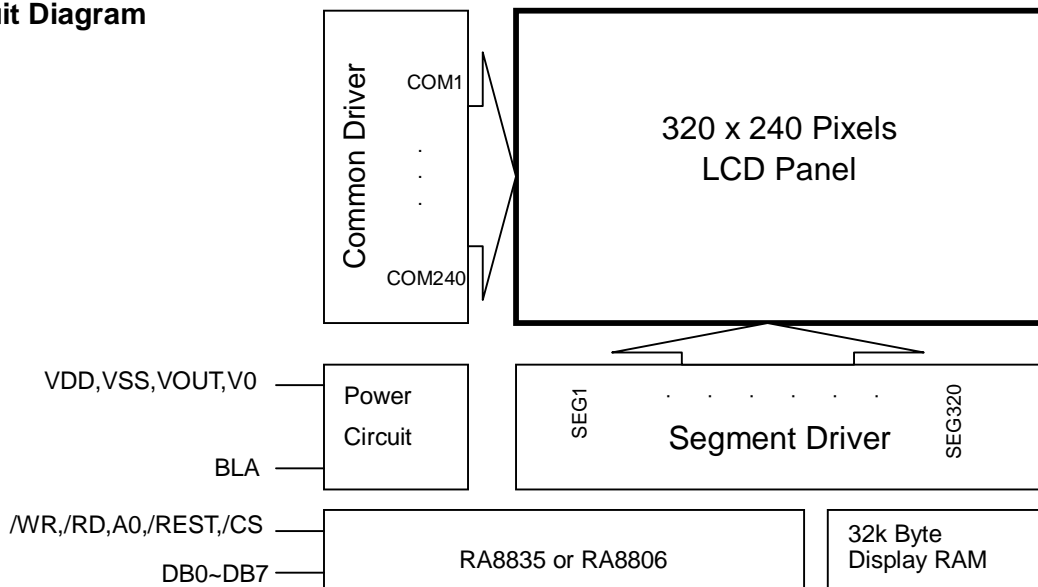

1.4 Interface Description

(1) CON1 接口定义

Pin No.	Pin Name	Function
1	VSS	Negative power supply,0V
2	VDD	Power supply voltage (Positive:5.0V OR 3.3V)
3	VOL	LCD Contrast Control
4	/WR(E)	Write Enable Input
5	/RD(R/W)	Read Enable Input
6	/CS	Chip Select Signal /CS = L, enable Access To The LCD module
7	A0(RS)	Data Type Select A0=H, Command Write, A0=L, Data Write
8	/REST	/RES = H, Normal Running /RES = L, Initialization is executed
9 ~ 16	DB0 ~ DB7	8-Bit Bi-directional Data Bus
17	NC	
18	VOUT	Power Booster Circuit Output
19	LEDA	Positive For Backlight (5.0V)
20	LEDK	Negative For Backlight

(2) CON2 接口定义

Pin No.	Pin Name	Function
1	DB0	4-Bit LCD Driver Data Bus
2	DB1	4-Bit LCD Driver Data Bus
3	DB2	4-Bit LCD Driver Data Bus
4	DB3	4-Bit LCD Driver Data Bus
5	/DISPOFF	LCD 显示关闭讯号 0 : LCD 画面关闭; 1 : LCD 画面显示
6	YD	LCD Per Frame 的起始讯号
7	FR	LCD AC Wave 控制讯号; 用来当作 LCD 驱动器电压准位偏移 (Level Shift) 的控制讯号。此讯号通常于 VDD/GND 间交替转换以避免 LCD 极化。
8	LP	LCD Common Latch 讯号; Common数据撷取讯号, 用以通知Driver, 要拴锁该行的资料。
9	XCK	LCD Common Latch 讯号; 资料以 XCK 为同步频率传送。
10	VDD	Power supply voltage (Positive:5.0V OR 3.3V)
11	VSS	Negative power supply,0V
12	VOUT	
13	VOL	LCD Contrast Control
14	FGND	Frame VSS
15	LEDA	Positive For Backlight (5.0V)

(3) CON3 接口定义

Pin No.	Pin Name	Function
1	VSS	Negative power supply,0V
2	VDD	Power supply voltage (Positive:5.0V OR 3.3V)
3	VOL	LCD Contrast Control
4	A0 (RS)	Data Type Select A0=H, Command Write, A0=L, Data Write
5	/WR(R/W)	Write Enable Input
6	/RD(E)	Read Enable Input
7~14	DB0 ~ DB7	8-Bit Bi-directional Data Bus
15	/CS	Chip Select Signal /CS = L, enable Access To The LCD module
16	/REST	/RES = H, Normal Running /RES = L, Initialization is executed
17	VOUT	Power Booster Circuit Output
18	NC	
19	FGND	Frame VSS
20	LEDA	Positive For Backlight (5.0V)

2. Absolute Maximum Ratings

Items	Symbol	MIN.	MAX.	Unit	Condition
Supply Voltage	V _{DD}	2.4	+5.0	V	Control Ic:RA8806
Input Voltage	V _{IN}	V _{SS} -0.3	V _{DD} +0.3	V	V _{SS} = 0V
Operating Temperature	T _{OP}	-20	+70	°C	No Condensation
Storage Temperature	T _{st}	-30	+80	°C	No Condensation

3. Electrical Characteristics

3.1 DC Characteristics

V_{SS} = 0V, T_{OP} = 25°C

Items	Symbol	MIN.	TYP.	MAX.	Unit	Condition
Operating Voltage(1)	V _{DD}	4.5	5.0	5.5	V	Control IC: RA8806
Operating Voltage(2)	V _{DD}	2.4	3.3	3.6	V	
Oscillator frequency	F _{osc}	4	8	12	MHz	V _{DD} =5.0v
Input High Voltage	V _{IH}	0.8 x V _{DD}	-	V _{DD}	V	/WR,/RD,/CS,A0, /RES,DB0~DB7
Input Low Voltage	V _{IL}	V _{SS}	-	0.2 x V _{DD}	V	
LCD Contrast Reference Voltage	V ₀	-	24.0	-	V	V ₀
Operating Current	I _{DD}	-	50.0	60.0	mA	V _{DD} =5..0V

3.2 LED Backlight Circuit

V_{SS} = 0V, T_{OP} = 25°C

Items	Symbol	MIN.	TYP.	MAX.	Unit	Condition
Forward Voltage	V _f BLA	-	5.0	-	V	Control IC: RA8806
Forward Current(1)	I _f BLA	-	150	200	mA	V _{DD} =5.0 V 10Pcs LED
Forward Current(2)	I _f BLA	-	75	100	mA	V _{DD} =5.0V 5Pcs LED

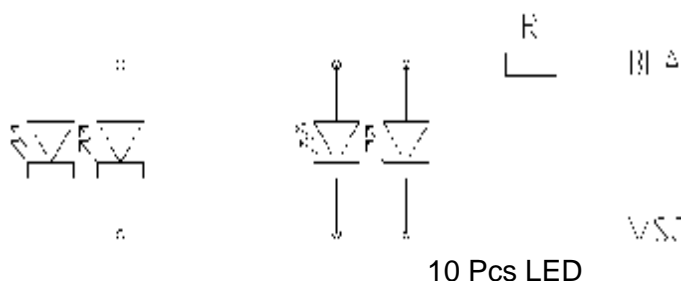

3.3 AC Characteristics

3.3.1 Command Write (Write Data to Register)

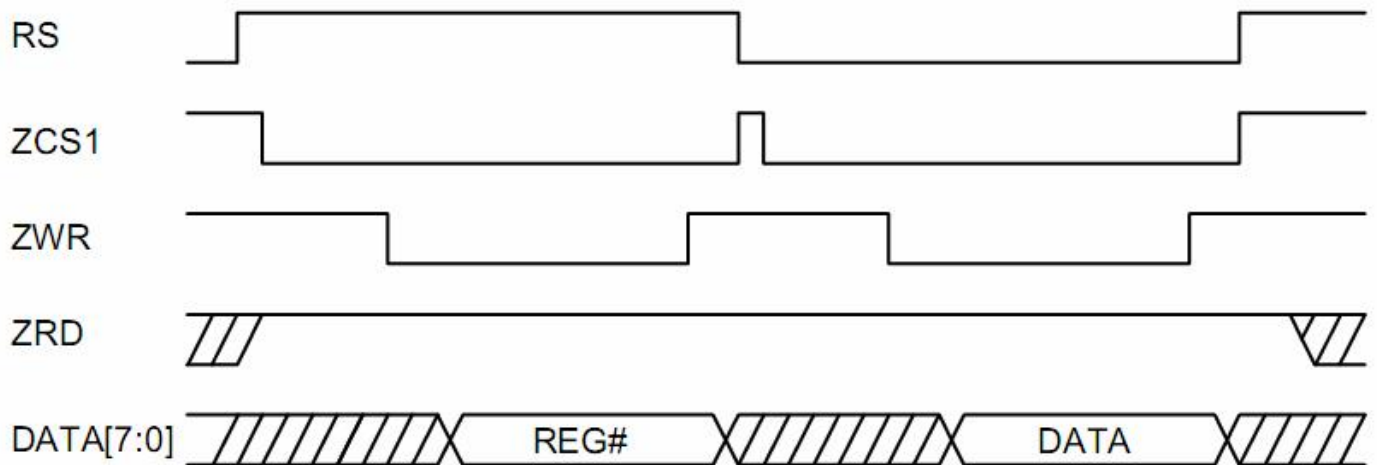

3.3.2 Read Data from Register

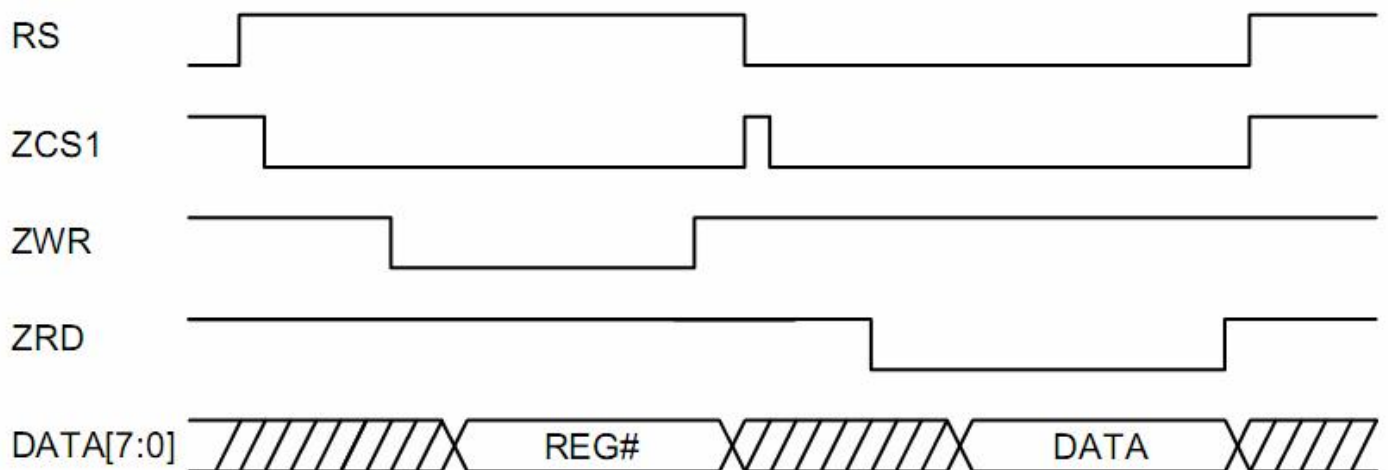

指令存取时间换算表

System Clock	Command Access Time
4MHz	1 μ s
6 MHz	667ns
8 MHz	500ns
10 MHz	400ns
12 MHz	333ns

3.3.3 8080 Mode System Bus Timing

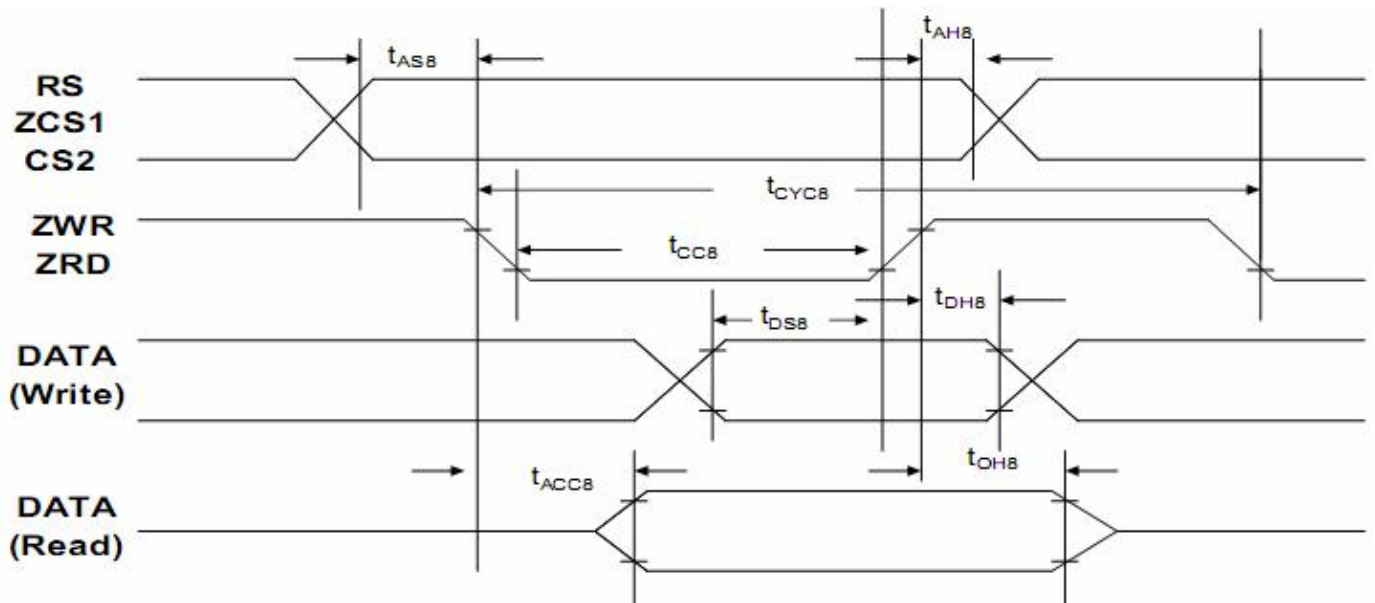
V_{ss} = 0V, Top = 25°C

Symbol	说明	Rating		Unit	Condition
		Min.	Max.		
t_{CYC8}	Cycle time	2*tc	--	ns	tc = one system clock period
t_{CC8}	Strobe Pulse width	50	--	ns	
t_{AS8}	Address setup time	0	--	ns	
t_{AH8}	Address hold time	20	--	ns	
t_{DS8}	Data setup time	30	--	ns	
t_{DH8}	Data hold time	20	--	ns	
t_{ACC8}	Data output access time	0	20	ns	
t_{OH8}	Data output hold time	0	10	ns	

3.3.4 6800 Mode System Bus Timing

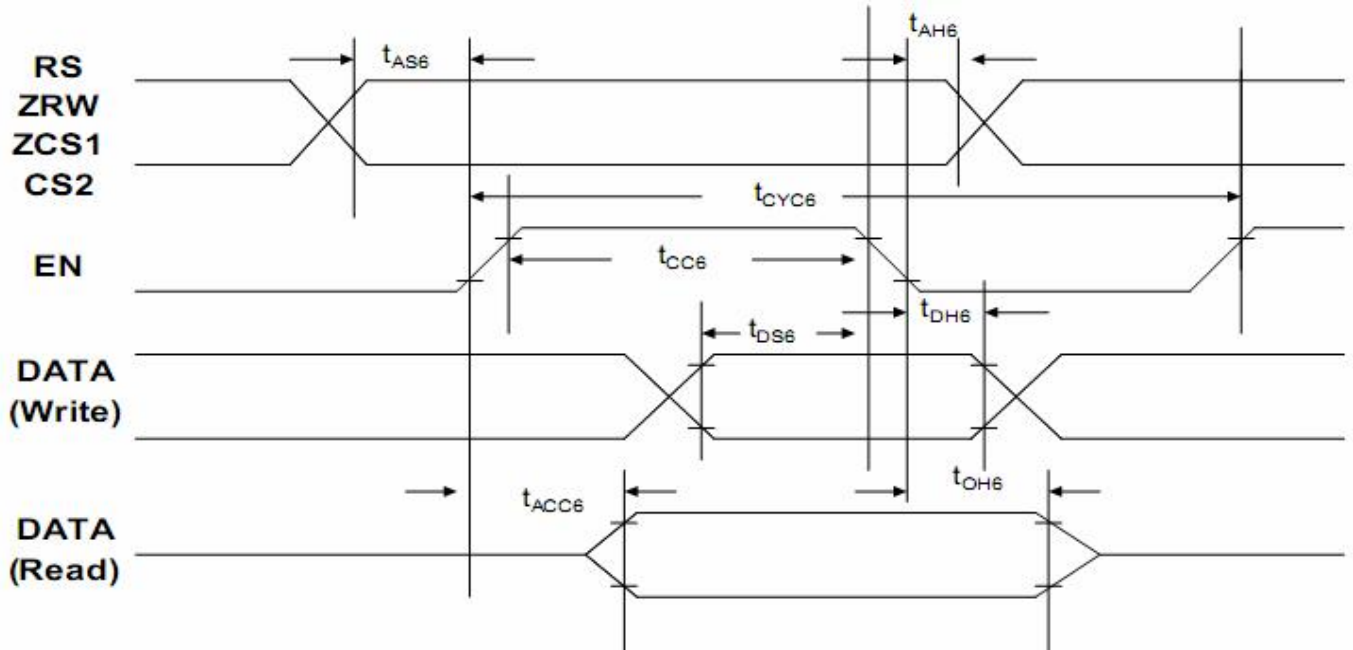
V_{ss} = 0V, Top = 25°C

Symbol	说明	Rating		Unit	Condition
		Min.	Max.		
t_{CYC6}	Cycle time	2*tc	--	ns	tc is one system clock period: tc = 1/CLK
t_{CC6}	Strobe Pulse width	50	--	ns	
t_{AS6}	Address setup time	0	--	ns	
t_{AH6}	Address hold time	20	--	ns	
t_{DS6}	Data setup time	30	--	ns	
t_{DH6}	Data hold time	20	--	ns	
t_{ACC6}	Data output access time	0	20	ns	
t_{OH6}	Data output hold time	0	10	ns	

3.4 Reset Timing

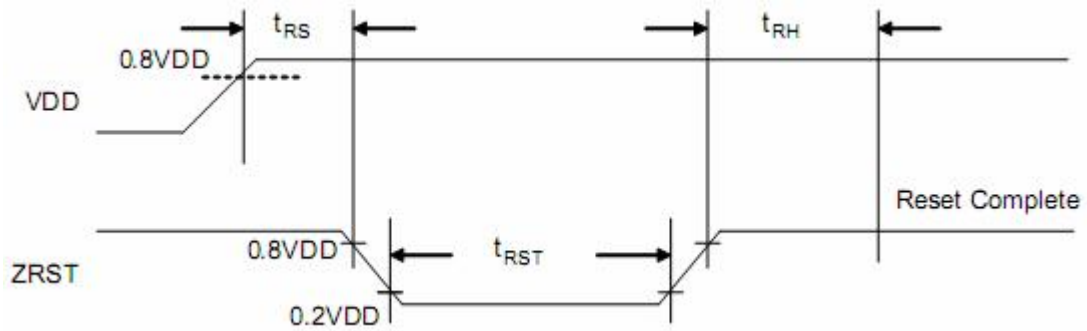

Items	Symbol	MIN.	TYP.	MAX.	Unit	Condition
Reset setup time	t _{RS}	1.0	-	-	mS	-
Reset hold time	t _{TH}	1.0	-	-	ms	
Reset active time	t _{RST}	-	-	1024	tc (*)	

V_{SS} = 0V, Top = 25°C

4. Function specifications

4.1 Adjusting the display contrast

A Variable-resistor must be connected to the LCD module for providing a reference to V0.

Adjusting the VR will result the change of LCD display contrast.

The recommended value of VR is 50k to 100k.

4.2 Resetting the LCD module

The LCD module should be initialized by using /RES terminal.

While turning on the VDD and VSS power supply, maintain /RES terminal at LOW level, After the

Power supply stabilized, release the reset terminal(/RES = High)

4.3 Interfacing setting

1> 68/80 = L , 8080 mode selected <default>

2> 68/80=H, 6800 mode selected

4.4 Display Pixel Map

1,1 (D7)	2,1 (D6)	3,1 (D5)	4,1 (D4)	5,1 (D3)	---	---	316,1 (D4)	317,1 (D3)	318,1 (D2)	319,1 (D1)	320,1 (D0)
1,2 (D7)	2,2 (D6)	3,2 (D5)	4,2 (D4)	5,2 (D3)	---	---	316,2 (D4)	317,2 (D3)	318,2 (D2)	319,2 (D1)	320,2 (D0)
1,3 (D7)	2,3 (D6)	3,3 (D5)	4,3 (D4)	5,3 (D3)	---	---	316,3 (D4)	317,3 (D3)	318,3 (D2)	319,3 (D1)	320,3 (D0)
:	:	:	:	:	:	:	:	:	:	:	:
:	:	:	:	:	:	:	:	:	:	:	:
:	:	:	:	:	:	:	:	:	:	:	:
1,238 (D7)	2,238 (D6)	3,238 (D5)	4,238 (D4)	5,238 (D3)	---	---	316,238 (D4)	317,238 (D3)	318,238 (D2)	319,238 (D1)	320,238 (D0)
1,239 (D7)	2,239 (D6)	3,239 (D5)	4,239 (D4)	5,239 (D3)	---	---	316,239 (D4)	317,239 (D3)	318,239 (D2)	319,239 (D1)	320,239 (D0)
1,240 (D7)	2,240 (D6)	3,240 (D5)	4,240 (D4)	5,240 (D3)	---	---	316,240 (D4)	317,240 (D3)	318,240 (D2)	319,240 (D1)	320,240 (D0)

Note:

- *a. Based on the top view of the LCD Module,
the 1,1(x,y) pixel is the upper-left pixel;
the 320,240(x,y) pixel is the lower-right pixel.

4.5 Display Commands

详细请看 (RA8806 缓存器内容描述, Page 14)

4.6 Basic Operating Sequence

详细请看 IC 资料和参考程序!

5. Inspection Standards

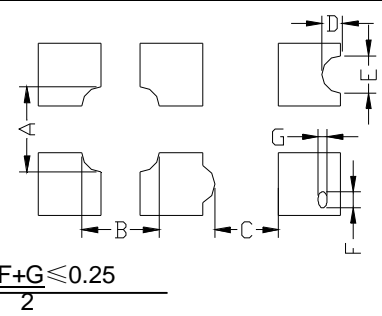
Item	Criterion for defects	Defect type
1) Display on inspection	(1) Non display (2) Vertical line is deficient (3) Horizontal line is deficient (4) Cross line is deficient	Major
2) Black / White spot	Size Φ (mm) Acceptable number $\Phi \leq 0.3$ Ignore (note) $0.3 < \Phi \leq 0.45$ 3 $0.45 < \Phi \leq 0.6$ 1 $0.6 < \Phi$ 0	Minor
3) Black / White line	Length (mm) Width (mm) Acceptable number $L \leq 10$ $W \leq 0.03$ Ignore $5.0 \leq L \leq 10$ $0.03 < W \leq 0.04$ 3 $5.0 \leq L \leq 10$ $0.04 < W \leq 0.05$ 2 $1.0 \leq L \leq 10$ $0.05 < W \leq 0.06$ 2 $1.0 \leq L \leq 10$ $0.06 < W \leq 0.08$ 1 $L \leq 10$ $0.08 < W$ follows 2) point defect Defects separate with each other at an interval of more than 20mm	Minor
4) Display pattern	 <p style="text-align: center;"> $\frac{A+B \leq 0.28}{2}$ $0 < C$ $\frac{D+E \leq 0.25}{2}$ $\frac{F+G \leq 0.25}{2}$ </p> <p>Note: 1) Up to 3 damages acceptable 2) Not allowed if there are two or more pinholes every three-fourth inch.</p>	Minor
5) Spot-like contrast irregularity	Size Φ (mm) Acceptable Number $\Phi \leq 0.7$ Ignore (note) $0.7 < \Phi \leq 1.0$ 3 $1.0 < \Phi \leq 1.5$ 1 $1.5 < \Phi$ 0 Note: 1) Conformed to limit samples. 2) Intervals of defects are more than 30mm.	Minor
6) Bubbles in polarizer	Size Φ (mm) Acceptable Number $\Phi \leq 0.4$ Ignore (note) $0.4 < \Phi \leq 0.65$ 2 $0.65 < \Phi \leq 1.2$ 1 $1.2 < \Phi$ 0	Minor
7) Scratches and dent on the polarizer	Scratches and dent on the polarizer shall be in the accordance with "2) Black/white spot", and "3) Black/White line".	Minor
8) Stains on the surface of LCD panel	Stains which cannot be removed even when wiped lightly with a soft cloth or similar cleaning.	Minor
9) Rainbow color	No rainbow color is allowed in the optimum contrast on state within the active area.	Minor
10) Viewing area encroachment	Polarizer edge or line is visible in the opening viewing area due to polarizer shortness or sealing line.	Minor
11) Bezel appearance	Rust and deep damages that are visible in the bezel are rejected.	Minor
12) Defect of land surface contact	Evident crevices that are visible are rejected.	Minor
13) Parts mounting	(1) Failure to mount parts (2) Parts not in the specifications are mounted (3) For example: Polarity is reversed, HSC or TCP falls off.	Minor
14) Part alignment	(1) LSI, IC lead width is more than 50% beyond pad outline. (2) More than 50% of LSI, IC leads is off the pad outline.	Minor
15) Conductive foreign matter (solder ball, solder hips)	(1) $0.45 < \Phi, N \geq 1$ (2) $0.3 < \Phi \leq 0.45, N \geq 1, \Phi$: Average diameter of solder ball (unit: mm) (3) $0.5 < L, N \geq 1, L$: Average length of solder chip (unit: mm)	Minor
16) Bezel flaw	Bezel claw missing or not bent	Minor
17) Indication on name plate (sampling indication label)	(1) Failure to stamp or label error, or not legible.(all acceptable if legible) (2) The separation is more than 1/3 for indication discoloration, in which the characters can be checked.	Minor

6. Handling Precautions

6.1 Mounting method

A panel of LCD module made by our company consists of two thin glass plates with polarizers that easily get damaged. And since the module is so constructed as to be fixed by utilizing fitting holes in the printed circuit board (PCB), extreme care should be used when handling the LCD modules.

6.2 Cautions of LCD handling and cleaning

When cleaning the display surface, use soft cloth with solvent (recommended below) and wipe lightly.

- Isopropyl alcohol
- Ethyl alcohol
- Trichlorotrifluoroethane

Do not wipe the display surface with dry or hard materials that will damage the polarizer surface.

Do not use the following solvent:

- Water
- Ketene
- Aromatics

6.3 Caution against static charge

The LCD module uses C-MOS LSI drivers. So we recommend you:

Connect any unused input terminal to V_{dd} or V_{ss} . Do not input any signals before power is turned on, and ground your body, work/assembly areas, assembly equipment to protect against static electricity.

6.4 Packaging

- Module employs LCD elements, and must be treated as such. Avoid intense shock and falls from a height.
- To prevent modules from degradation, do not operate or store them exposed directly to sunshine or high temperature/humidity.

6.5 Caution for operation

-It is an indispensable condition to drive LCD module within the limits of the specified voltage since the higher voltage over the limits may cause the shorter life of LCD module.

- An electrochemical reaction due to DC (direct current) causes LCD undesirable deterioration so that the uses of DC (direct current) drive should be avoided.

-Response time will be extremely delayed at lower temperature than the operating temperature range and on the other hand at higher temperature LCD module may show dark color in them. However those phenomena do not mean malfunction or out of order of LCD module, which will come back in the specified operating temperature.

6.6 Storage

In the case of storing for a long period of time, the following ways are recommended:

- Storage in polyethylene bag with the opening sealed so as not to enter fresh air outside in it. And with not desiccant.
- Placing in a dark place where neither exposure to direct sunlight nor light is. Keeping the storage temperature range.
- Storing with no touch on polarizer surface by any thing else.

6.7 Safety

-It is recommendable to crush damaged or unnecessary LCD into pieces and to wash off liquid crystal by either of solvents such as acetone and ethanol, which should be burned up later.

-When any liquid leaked out of a damaged glass cell comes in contact with your hands, please wash it off well at once with soap and water.