

LCM MODULE SPECIFICATION

MODULE NO.
HTG240160C

Customer Approval

--

Designed	Checked	Approved

Revision history

revision	date	description	remark
A00	2008-02-25	First release	

Content

1. Feature	1
2. Mechanical specifications	1
3. Block diagram & power supply	2
4. Pin description	3
5. Absolute maximum rating	4
6. Electrical characteristics	4
DC characteristics	4
6.2 AC characteristics	5
6.3 Reset timing	6
7. Backlight characteristics	6
8. Electrical-optical characteristics	6
9. Control and display commands	9
10. Inspection standards	10
11. Reliability test	11
12. Handling precautions	11

1. Feature

Display resolution	: 240(w)*160(h)
Display mode	: STN , Blue, negative , transmissive
Driving method	: 1/128 duty , 1/12 bias
Viewing direction	: 6 o'clock
Backlight	: White
Built-in controller	: ST7529
Operation temp	: -10°C~60°C
Storage temp	: -20°C~70°C

2. Mechanical Specifications

Dimensional outline (W*H*T)	: 77.4mm*61.0mm*4.6mm
Viewing area (W*H)	: 73.42mm*48.0mm
Dot pitch (W*H)	: 0.281mm*0.281mm
Dot size (W*H)	: 0.261mm*0.261mm
Weight	: Approx

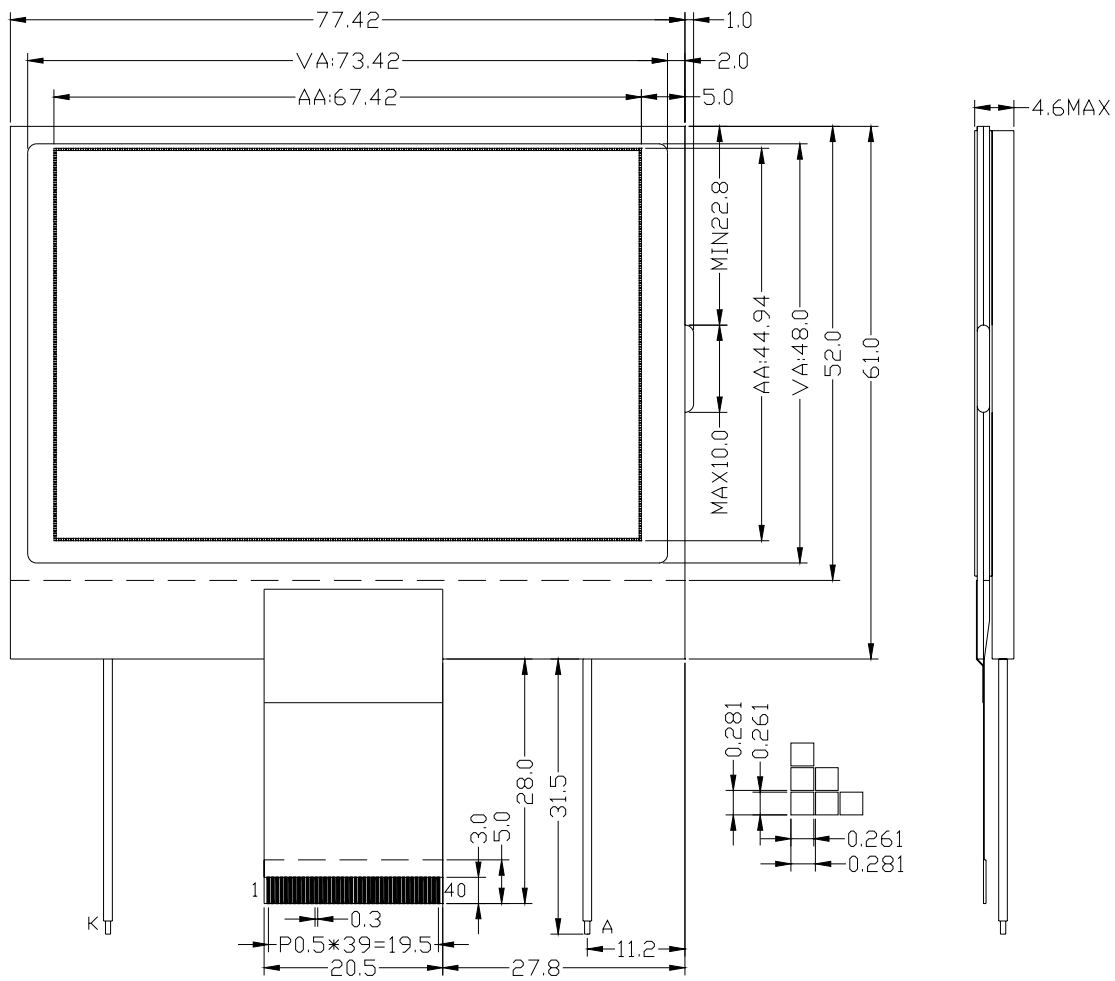

outline dimension

2. Block Diagram & Power supply

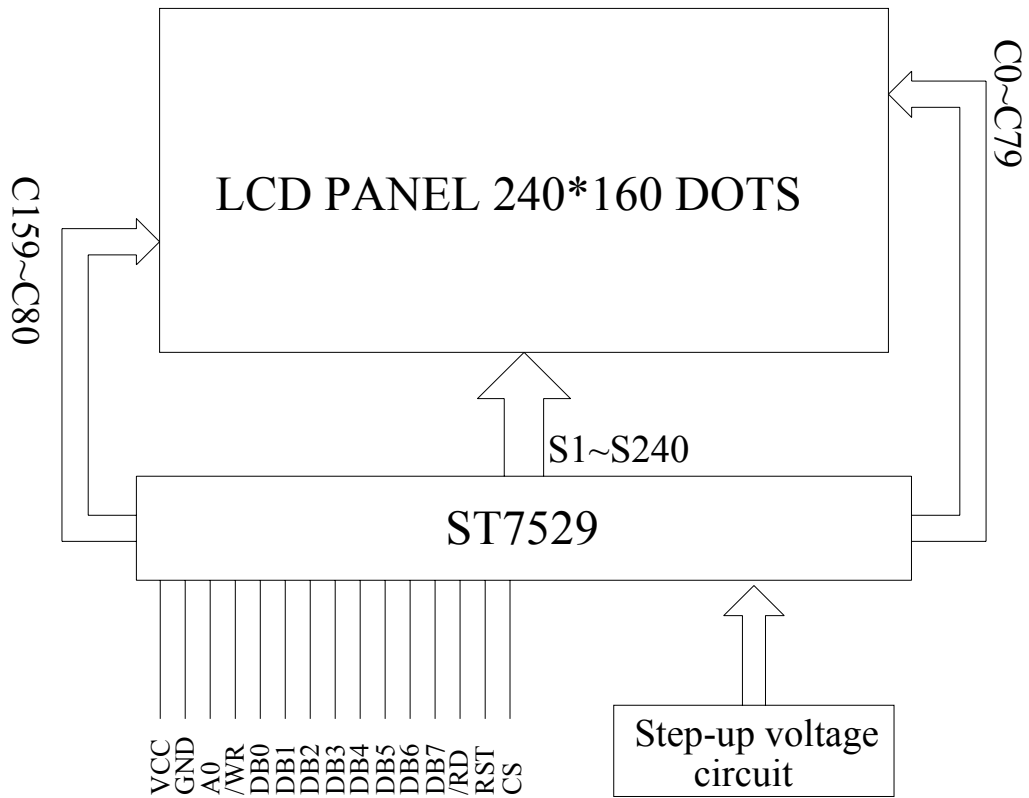

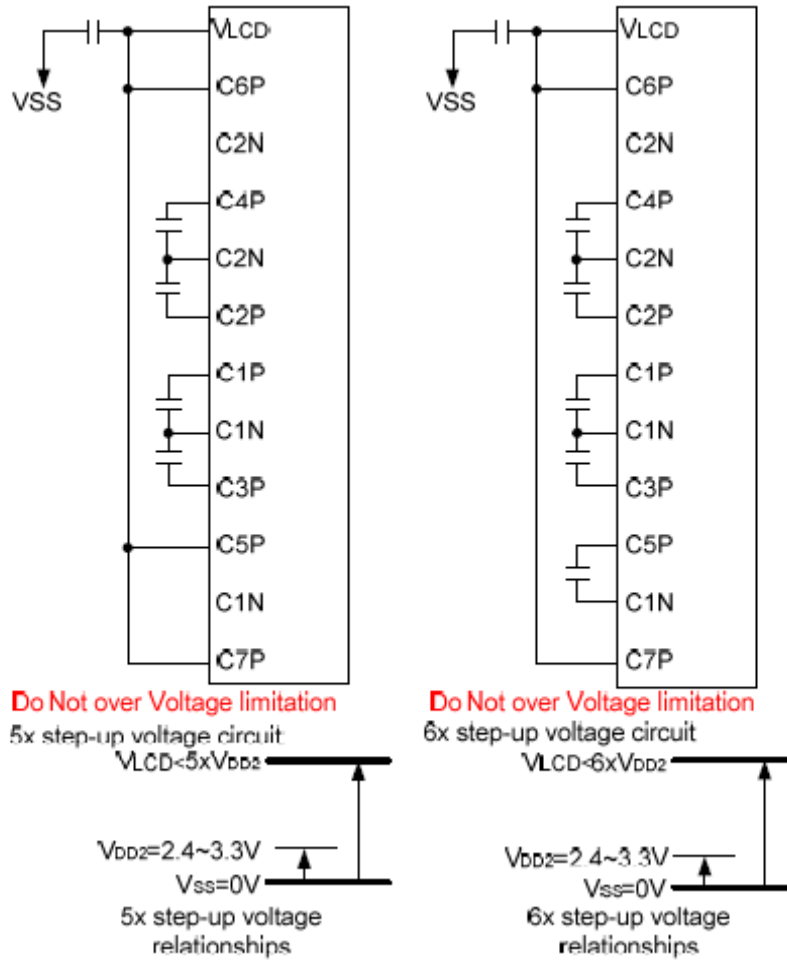

4. Pin description

Pin No.	Pin Name	Function
1	A0	Register selection (H : data register ; L : instruction register)
2	/WR	Write signal
3~18	DB0~DB15	Data bus
19	/RD	Read signal
20	/RES	Reset signal
21	IF3	8-bit/16-bit data bus selection
22	/CS	Chip enable
23	VDD	Power supply for logic(+3.0V)
24	VSS	Power supply (ground)
25	VDD2	Power supply for booster circuit(+3.0V)

26	C7+	Capacitor positive connection
27	C5+	Capacitor positive connection
28	C3+	Capacitor positive connection
29	C1-	Capacitor negative connection
30	C1+	Capacitor positive connection
31	C2+	Capacitor positive connection
32	C2-	Capacitor negative connection
33	C4+	Capacitor positive connection
34	C6+	Capacitor positive connection
35	Vlcd	External LCD driver voltage supply
36	V4	LCD driver supply voltage
37	V3	LCD driver supply voltage
38	V2	LCD driver supply voltage
39	V1	LCD driver supply voltage
40	V0	LCD driver supply voltage

5. Absolute Maximum Ratings

Items	Symbol	MIN.	MAX.	Unit	Condition
Supply Voltage	V _{DD}	-0.3	+3.6	V	V _{SS} = 0V
	V _{lcd}	-0.3	+13.5	V	V _{SS} = 0V
Input Voltage	V _{IN}	-0.3	V _{DD} +0.3	V	V _{SS} = 0V
LED forward current	I _f	---	---	mA	---
Operating Temperature	T _{OP}	-0	+50	°C	---
Storage Temperature	T _{st}	-10	+60	°C	---

6. Electrical Characteristics

6.1 DC Characteristics

(V_{SS} = 0V, V_{DD} = 5.0V ± 10%, T_a = -20~75°C)

Items	Symbol	MIN.	TYP.	MAX.	Unit
-------	--------	------	------	------	------

Operating Voltage	V _{DD}	2.4	3.0	4.0	V
Input High Voltage	V _{IH}	0.8V _{DD}	-	V _{DD}	V
Input Low Voltage	V _{IL}	V _{SS}	-	0.2V _{DD}	V
Output High Voltage	V _{OH}	0.8V _{DD}	-	V _{DD}	V
Output Low Voltage	V _{OL}	V _{SS}	-	0.2V _{DD}	V
Supply Current	I _{DD}	---	---	15	mA

6.2 AC Characteristics

System Bus Read/Write Characteristics 1 (For the 8080 Series MPU)

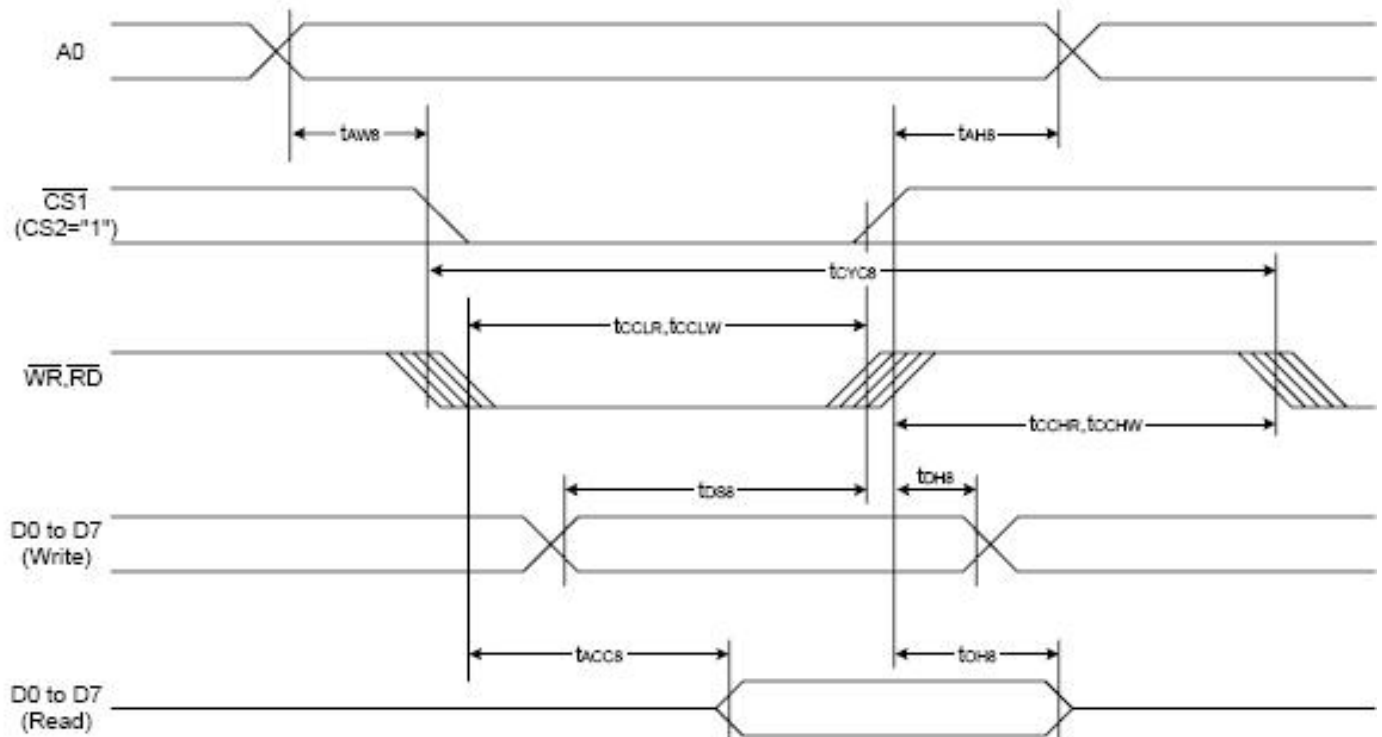

Figure 37

Table 24

(V_{DD} = 3.3V, T_a = -30 to 85°C)

Item	Signal	Symbol	Condition	Rating		Units
				Min.	Max.	
Address hold time	A0	t _{AHB}		0	—	Ns
Address setup time		t _{AWB}		0	—	
System cycle time		t _{CYCS}		240	—	
Enable L pulse width (WRITE)	WR	t _{CCLW}		80	—	
Enable H pulse width (WRITE)		t _{CCHW}		80	—	
Enable L pulse width (READ)	RD	t _{CCLR}		140	—	
Enable H pulse width (READ)		t _{CCHR}		80	—	
WRITE Data setup time	D0 to D7	t _{DSE}		40	—	
WRITE Address hold time		t _{DHE}		0	—	
READ access time		t _{ACCs}	CL = 100 pF	—	70	
READ Output disable time		t _{OHE}	CL = 100 pF	5	50	

6.3 Reset timing

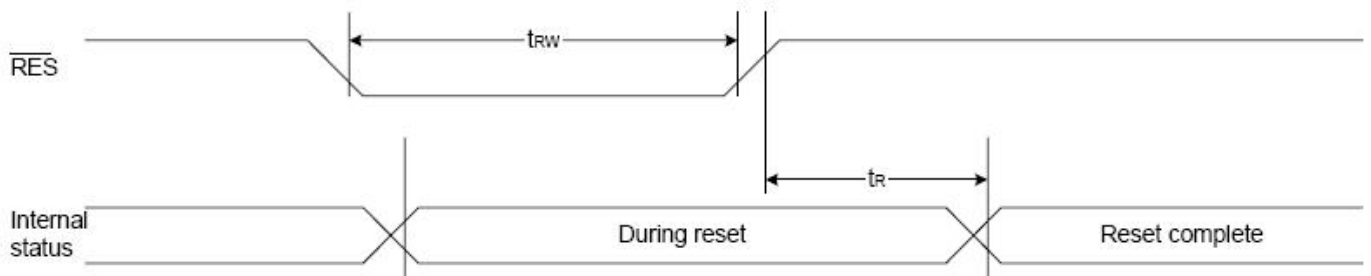

Figure 41

Table 30

(V_{DD} = 3.3V, T_a = -30 to 85°C)

Item	Signal	Symbol	Condition	Rating			Units
				Min.	Typ.	Max.	
Reset time		t _R		—	—	1.0	us
Reset "L" pulse width	/RES	t _{RW}		1.0	—	—	us

7. Backlight Characteristics

Items	Symbol	MIN.	TYP.	MAX.	Unit	Condition
Forward Voltage	V _f	2.8	3.0	3.2	V	I _f =60mA
Reverse current	I _r	---	-	100	uA	V _r =5V
Peak wave length	λ	-	-	-	nM	I _f =60mA
Luminance	L _v	---	---	---	Cd/m ²	I _f =60mA
Color	White					

8. Electrical-Optical Characteristics

Items	Symbol	Condition	MIN.	TYP.	MAX.	Unit	NOTE
Operation Voltage	V _{op}	T _a = -20°C	8.0	8.5	9.8	V	1
		T _a = 25°C	7.7	8.0	8.3		
		T _a = 70°C	7.2	7.5	7.8		
Response time	T _r	T _a = 25°C	---	185	---	ms	2
	T _f		---	200	---		
Contrast ratio	Cr	T _a = 25°C	---	5	---	degree	3
Viewing angle range	θ	Cr ≥ 2	-40	---	40		

Note1 Definition of Operation voltage

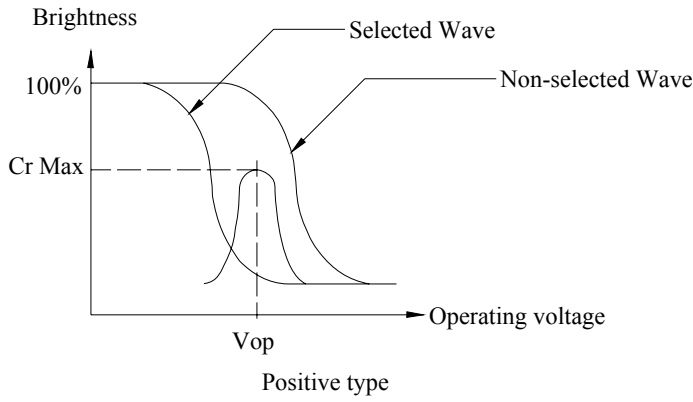

Note2 Definition of Response time

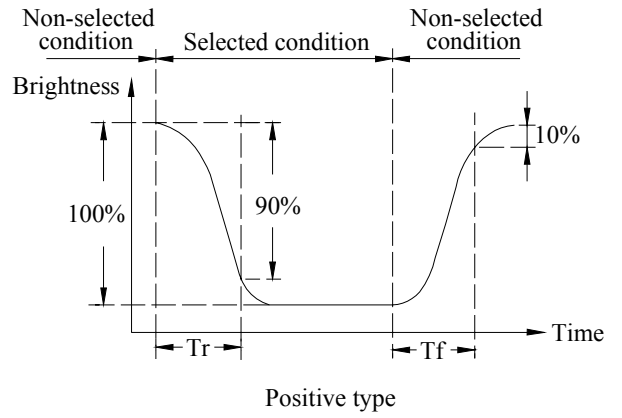

Note3 Definition of Contrast ratio, Viewing angle and direction

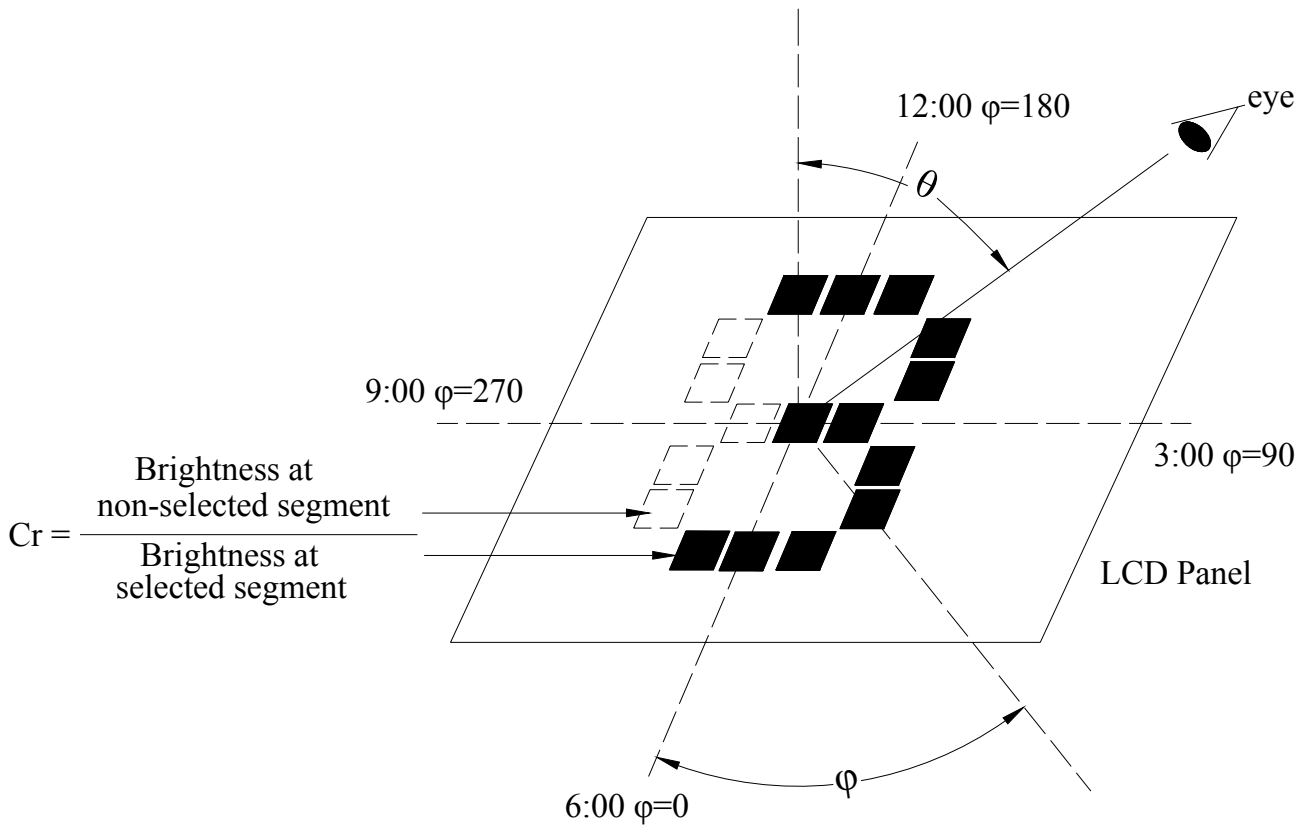

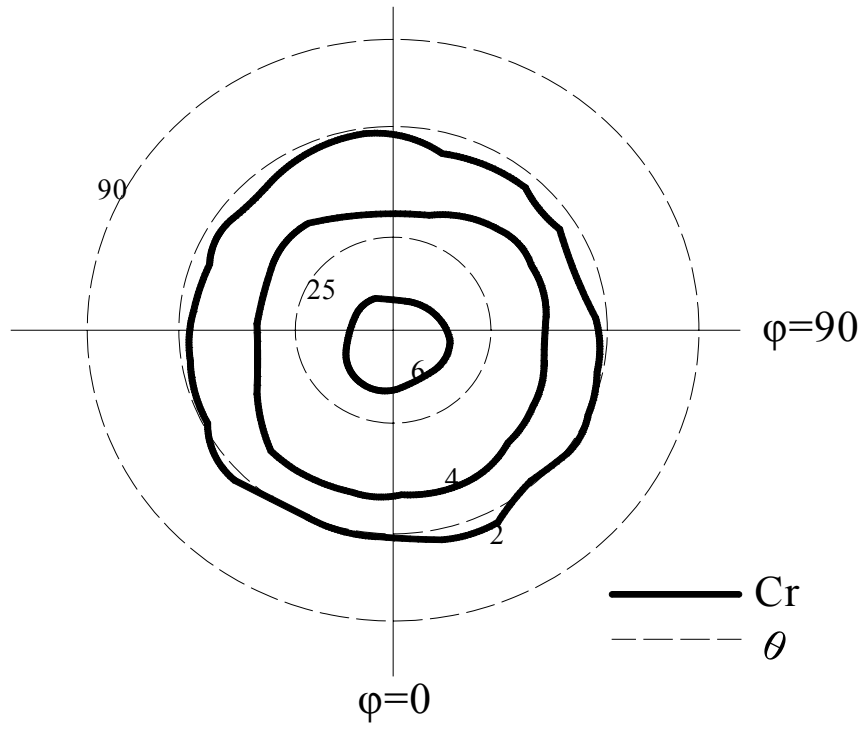

9. Control and display commands

(note * : ignore data)

Command	Command Code										Function	
	A0	/RD	/WR	D7	D6	D5	D4	D3	D2	D1		D0
(1) Display ON/OFF	0	1	0	1	0	1	0	1	1	1	0	LCD display ON/OFF 0: OFF, 1: ON
(2) Display start line set	0	1	0	0	1	Display start address					1	Sets the display RAM display start line address
(3) Page address set	0	1	0	1	0	1	1	Page address				Sets the display RAM page address
(4) Column address set upper bit	0	1	0	0	0	0	1	Most significant column address				Sets the most significant 4 bits of the display RAM column address.
Column address set lower bit				0	0	0	0	Least significant column address				Sets the least significant 4 bits of the display RAM column address.
(5) Status read	0	0	1	Status			0	0	0	0	0	Reads the status data
(6) Display data write	1	1	0	Write data							0	Writes to the display RAM
(7) Display data read	1	0	1	Read data							0	Reads from the display RAM
(8) ADC select	0	1	0	1	0	1	0	0	0	0	0	Sets the display RAM address SEG output correspondence 0: normal, 1: reverse
(9) Display normal/reverse	0	1	0	1	0	1	0	0	1	1	0	Sets the LCD display normal/ reverse 0: normal, 1: reverse
(10) Display all points ON/OFF	0	1	0	1	0	1	0	0	1	0	0	Display all points 0: normal display 1: all points ON
(11) LCD bias set	0	1	0	1	0	1	0	0	0	1	0	Sets the LCD drive voltage bias ratio 0: 1/9 bias, 1: 1/7 bias (ST7565R)
(12) Read-modify-write	0	1	0	1	1	1	0	0	0	0	0	Column address increment At write: +1 At read: 0
(13) End	0	1	0	1	1	1	0	1	1	1	0	Clear read/modify/write
(14) Reset	0	1	0	1	1	1	0	0	0	1	0	Internal reset
(15) Common output mode select	0	1	0	1	1	0	0	0	*	*	*	Select COM output scan direction 0: normal direction 1: reverse direction
(16) Power control set	0	1	0	0	0	1	0	1	Operating mode		0	Select internal power supply operating mode
(17) V _D voltage regulator internal resistor ratio set	0	1	0	0	0	1	0	0	Resistor ratio		0	Select internal resistor ratio(Rb/Ra) mode
(18) Electronic volume mode set	0	1	0	1	0	0	0	0	0	0	1	Set the V _D output voltage electronic volume register
Electronic volume register set				0	0	Electronic volume value				0	0	
(19) Sleep mode set	0	1	0	1	0	1	0	1	1	0	0	0: Sleep mode, 1: Normal mode
(20) Booster ratio set	0	1	0	1	1	1	1	1	0	0	0	select booster ratio 00: 2x,3x,4x 01: 5x 11: 6x
(21) NOP	0	1	0	1	1	1	0	0	0	1	1	Command for non-operation
(22) Test	0	1	0	1	1	1	1	*	*	*	*	Command for IC test. Do not use this command

See the datasheet of ST7565R for detail

10. Inspection Standards

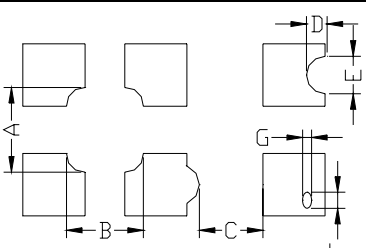
Item	Criterion for defects	Defect type
1) Display on inspection	(1) Non display (2) Vertical line is deficient (3) Horizontal line is deficient (4) Cross line is deficient	Major
2) Black / White spot	Size Φ (mm) $\Phi \leq 0.3$ Acceptable number $0.3 < \Phi \leq 0.45$ Ignore (note) $0.45 < \Phi \leq 0.6$ 3 $0.6 < \Phi$ 1 0	Minor
3) Black / White line	Length (mm) Width (mm) Acceptable number $L \leq 10$ $W \leq 0.03$ Ignore $5.0 \leq L \leq 10$ $0.03 < W \leq 0.04$ 3 $5.0 \leq L \leq 10$ $0.04 < W \leq 0.05$ 2 $1.0 \leq L \leq 10$ $0.05 < W \leq 0.06$ 2 $1.0 \leq L \leq 10$ $0.06 < W \leq 0.08$ 1 $L \leq 10$ $0.08 < W$ follows 2) point defect Defects separate with each other at an interval of more than 20mm	Minor
4) Display pattern	 $\frac{A+B \leq 0.28}{2} \quad 0 < C \quad \frac{D+E \leq 0.25}{2} \quad \frac{F+G \leq 0.25}{2}$ <p>Note: 1) Up to 3 damages acceptable 2) Not allowed if there are two or more pinholes every three-fourth inch.</p>	Minor
5) Spot-like contrast irregularity	Size Φ (mm) Acceptable Number $\Phi \leq 0.7$ Ignore (note) $0.7 < \Phi \leq 1.0$ 3 $1.0 < \Phi \leq 1.5$ 1 $1.5 < \Phi$ 0 Note: 1) Conformed to limit samples. 2) Intervals of defects are more than 30mm.	Minor
6) Bubbles in polarizer	Size Φ (mm) Acceptable Number $\Phi \leq 0.4$ Ignore (note) $0.4 < \Phi \leq 0.65$ 2 $0.65 < \Phi \leq 1.2$ 1 $1.2 < \Phi$ 0	Minor
7) Scratches and dent on the polarizer	Scratches and dent on the polarizer shall be in the accordance with "2) Black/white spot", and "3) Black/White line".	Minor
8) Stains on the surface of LCD panel	Stains which cannot be removed even when wiped lightly with a soft cloth or similar cleaning.	Minor
9) Rainbow color	No rainbow color is allowed in the optimum contrast on state within the active area.	Minor
10) Viewing area encroachment	Polarizer edge or line is visible in the opening viewing area due to polarizer shortness or sealing line.	Minor
11) Bezel appearance	Rust and deep damages that are visible in the bezel are rejected.	Minor
12) Defect of land surface contact	Evident crevices that are visible are rejected.	Minor
13) Parts mounting	(1) Failure to mount parts (2) Parts not in the specifications are mounted (3) For example: Polarity is reversed, HSC or TCP falls off.	Minor
14) Part alignment	(1) LSI, IC lead width is more than 50% beyond pad outline. (2) More than 50% of LSI, IC leads is off the pad outline.	Minor
15) Conductive foreign matter (solder ball, solder hips)	(1) $0.45 < \Phi$, $N \geq 1$ (2) $0.3 < \Phi \leq 0.45$, $N \geq 1$, Φ : Average diameter of solder ball (unit: mm) (3) $0.5 < L$, $N \geq 1$, L : Average length of solder chip (unit: mm)	Minor
16) Bezel flaw	Bezel claw missing or not bent	Minor
17) Indication on name plate (sampling indication label)	(1) Failure to stamp or label error, or not legible.(all acceptable if legible) (2) The separation is more than 1/3 for indication discoloration, in which the characters can be checked.	Minor

11. Reliability test

item	condition	criterion
High temp. operation	80°C 24hrs	No abnormality in function and appearance
High temp. storage	70°C 24hrs	
Low temp. operation	-20°C 24hrs	
Low temp. storage	-30°C 24hrs	
Humidity	40°C 90%RH 24hrs	
Thermal shock	0°C(30min)← →50°C(30min) 10cycles	
Vibration	Frequency :10~55HZ Duration : 3times , 3min/time Amplitude : 0.75mm	-

12. Handling precautions

1. Refrain from strong mechanical shock and forces to the module. It may cause improper operating or damage to the module.
2. The polarizer used on the display surface is easily scratched and damaged. Extreme care should be taken when handling. When cleaning the display surface, use soft cloth with a solvent recommended : ethyl alcohol , isopropyl or hexane) and wipe gently, do not use the following solvents : water, ketone or aromatics .
3. Wipe off water or oil drop immediately If you leave drop for a long time, stain and discoloration may occur.
4. Do not touch pads or pins of interface directly with bare hands. When handling the LCD module, put on a soft glover like finger-glover.
5. Protect the module from static electricity, it may cause damage to CMOS LSI.
6. To prevent LCD panels from degradation, do not operate or store them exposed directly to sunlight or high temperature/humidity.
7. If the liquid crystal leaks from the panel it should be kept away from the eyes and mouths. In case of contact with skins, wash away thoroughly with soap and water.
8. Soldering should be only performed on the I/O terminals within the temperature of $280 \pm 20^{\circ}\text{C}$ and soldering time should be less than 4 seconds.
9. Supply voltage within the specified voltage limit, the maximum rating, higher voltage cause the shorter LCD life or damaged.
10. Do not input any signals before power is turned on. Do not connect or disconnect the module on the state of Power-ON.