

SSD2533

Advanced Information

**23 Driving x 41 Sensing
Capacitive Touch Panel Controller**

This document contains information on a new product. Specifications and information herein are subject to change without notice.

Appendix: IC Revision history of SSD2533 Specification

Version	Change Items	Effective Date
0.10	1 st Release	26-Oct-10
0.20	<ol style="list-style-type: none"> 1. Ordering Information 2. Added Functional Block Description 3. Added Command Register Table 4. Added Command Description 	12-Jan-11
0.30	<ol style="list-style-type: none"> 1. Remove SSD2533 QN5 information and package 2. Replace SSD2533QT6 to QT2 3. Update the Table 15-1, Table 15-2, Page 41 	10-Mar-11
0.40	<ol style="list-style-type: none"> 1. Revised SSD2533QN4 pin definitions on P.10 2. Revised orientation presented on pin definitions on P.9,10 3. Revised IIC address on P.11, 13 4. Revised initialization program code 	17-Mar-11
1.0	<ol style="list-style-type: none"> 1. Added SSD2533QN10 (QFN88) Information (p.7) 2. Added 88 pins QFN (p.11) 3. Revised command description on 0x25, 0x27, 0x2A, 0x37, added 0x2C. (p.17) 4. Revised command description on 0x7A (p.19) 5. Revised command description on R2Ah, added R2Ch (p.26) 6. Revised command description on R30h, R33h, R34h, R35h (p.27) 7. Revised command description on R3Eh (p.28) 8. Revised command description on R68h, R69h (p.29) 9. Revised command description on R79h and R7Ah (p.30) 10. Revised the graph and description on R86h, R87h, RDBh (p31-32) 11. Revised Isleep/Idp definition (p.34) 12. Revised “Power saving mode” and “Normal Mode” Sequence (p.37) 13. Added pull high resistor and RF filter capacitor on figure 15-1 (p.40) 14. Revised the initialization program (p.46) 15. Added QFN 88 pins package information (p.52) 16. Added SSD2533QN10 package information (p.55) 	25-Aug-11
1.1	<ol style="list-style-type: none"> 1. Added SSD2533QN4A (QFN68) Information (p.7) 2. Add pin arrangement for SSD2533QN4A (p.11) 	05-Jan-12

CONTENTS

1	GENERAL DESCRIPTION	7
2	FEATURES.....	7
3	ORDERING INFORMATION	7
4	BLOCK DIAGRAM	8
5	PIN ARRANGEMENT.....	9
5.1	100 PINS TQFP	9
5.2	68 PINS QFN	10
5.3	88 PINS QFN	12
6	PIN DESCRIPTIONS.....	13
6.1	POWER.....	13
6.2	LOGIC	13
6.3	ANALOG	14
6.4	INPUT AND OUTPUT	14
7	FUNCTIONAL BLOCK DESCRIPTIONS.....	15
7.1	STYPE0, STYPE1, GPIO3	15
7.2	MCU	15
7.3	ADC.....	15
7.4	ANALOG BOOSTER CIRCUIT	15
7.5	IIC INTERFACE (MASTER/SLAVE).....	15
7.6	41 PINS SENSING INPUT	15
7.7	23 PINS DRIVING OUTPUT AMPLIFIER	15
7.8	4 PINS SELF-CAP INPUT	15
8	COMMAND TABLE	16
9	COMMAND DESCRIPTIONS.....	23
10	REGISTERS.....	34
11	MAXIMUM RATINGS.....	35
12	DC CHARACTERISTICS.....	35
13	AC CHARACTERISTICS.....	36
14	POWER UP/DOWN SEQUENCE	38
14.1	POWER UP / DOWN FLOW CHART	38
14.2	POWER UP	39
14.3	POWER DOWN	40
15	APPLICATION EXAMPLES	41
15.1	APPLICATION DIAGRAM	41
15.2	PANEL DESIGN REFERENCE	42
15.3	FPC DESIGN REFERENCE.....	44
15.4	FPC LAYOUT EXAMPLE FOR QFP100 WITH EEPROM.....	45
15.5	INITIALIZATION PROGRAM.....	47
16	PACKAGE INFORMATION.....	49

16.1	TQFP 100 PINS (12X12MM).....	49
16.2	QFN 68 PINS (8X8MM).....	52
16.3	QFN 88 PINS (10 X 10 MM).....	53
16.4	PACKAGE ORIENTATION.....	54

TABLES

TABLE 3-1: ORDERING INFORMATION	7
TABLE 5-1 : 100 PINS TQFP PIN ASSIGNMENT TABLE.....	9
TABLE 5-2 : 68 PINS QFN PIN ASSIGNMENT TABLE FOR SSD2533QN4	10
TABLE 5-3 : 68 PINS QFN PIN ASSIGNMENT TABLE FOR SSD2533QN4A.....	11
TABLE 5-4 : 88 PINS QFN PIN ASSIGNMENT TABLE.....	12
TABLE 11-1: MAXIMUM RATINGS (VOLTAGE REFERENCED TO V _{SS}).....	35
TABLE 13-1 :I ² C INTERFACE TIMING CHARACTERISTICS.....	36
TABLE 13-2 : SERIAL TIMING CHARACTERISTICS (TA = -40 to 85 ° C, VDDIO = 2.7V, VSS =0V).....	37
TABLE 15-1 : 5 INCH TOUCH PANEL CHARACTERISTICS.....	43
TABLE 15-2 : 7 TO 10 INCH TOUCH PANEL CHARACTERISTICS	43

FIGURES

FIGURE 4-1: SSD2533 BLOCK DIAGRAM	8
FIGURE 5-1: PIN-OUT DIAGRAM – 100 PINS TQFP (TOP VIEW).....	9
FIGURE 5-2: PIN-OUT DIAGRAM – 68 PINS QFN (TOP VIEW).....	10
FIGURE 5-3: PIN-OUT DIAGRAM – 68 PINS QFN (TOP VIEW).....	11
FIGURE 5-4: PIN-OUT DIAGRAM – 88 PINS QFN (TOP VIEW).....	12
FIGURE 13-1 : I ² C INTERFACE TIMING CHARACTERISTICS.....	36
FIGURE 13-2 : SERIAL TIMING CHARACTERISTICS.....	37
FIGURE 15-1: APPLICATION EXAMPLE.....	41
FIGURE 16-1 : SSD2533QT6 PACKAGE ORIENTATION	54
FIGURE 16-2 : SSD2533QN4 PACKAGE ORIENTATION	55
FIGURE 16-3 : SSD2533QN10 PACKAGE ORIENTATION	56

1 GENERAL DESCRIPTION

SSD2533 is an all in one capacitive touch panel driver that integrated the power circuits, driving and sensing circuits into a single MCU based chip. It can drive capacitive type touch panel with up to 23 driving and 41 sensing lines.

2 FEATURES

- Operating voltage for IIC communication:
 - VCI: 2.5 ~ 3.3V
 - VDDIO: 1.65 ~ 3.3V
- 5.5V to 9V(max.) driving voltage with external booster Caps
- 16 steps in 0.5V increment programmable driving voltage control
- 16 bit MCU core
- 2K x 16 bit RAM for external EEPROM boot load
- 16K x 16-bit Internal ROM
- Support 2560x1408 touch resolution and capable to support up to Full-HD panel
- Support 100Hz max. sampling rate (25 ~100Hz user programmable)
- Total 23 driving and 41 sensing pins
- Fully programmable driver scanning order
- 8 choices for Touch Screen Orientation control
- Provide (X,Y) coordinates and number of touch points with force index and speed index
- 4 independent capacitive sensing pins and 4 independent GPIO pins
- Support up to 10 fingers
- Automatic mode switching (Normal, Idle)
- Auto calibration for each cross-over point
- Support IIC (up to 400kbits/sec) and USB 1.1 interface
- Package: QFN68, QFN88 and TQFP100

3 ORDERING INFORMATION

Table 3-1: Ordering Information

Ordering Part Number	Drive	Sense	Package Form	MOQ / MPQ	Remark
SSD2533QN4	23	12	QFN-68 (Tray)	260/2600	IIC Only
SSD2533QN4A	21	28	QFN-68(Tray)	260/2600	IIC Only
SSD2533QT6	23	41	TQFP-100 (Tray)	119/1190	IIC , USB 1.1
SSD2533QN10	23	38	QFN-88(Tray)	168/1680	IIC, USB 1.1

4 BLOCK DIAGRAM

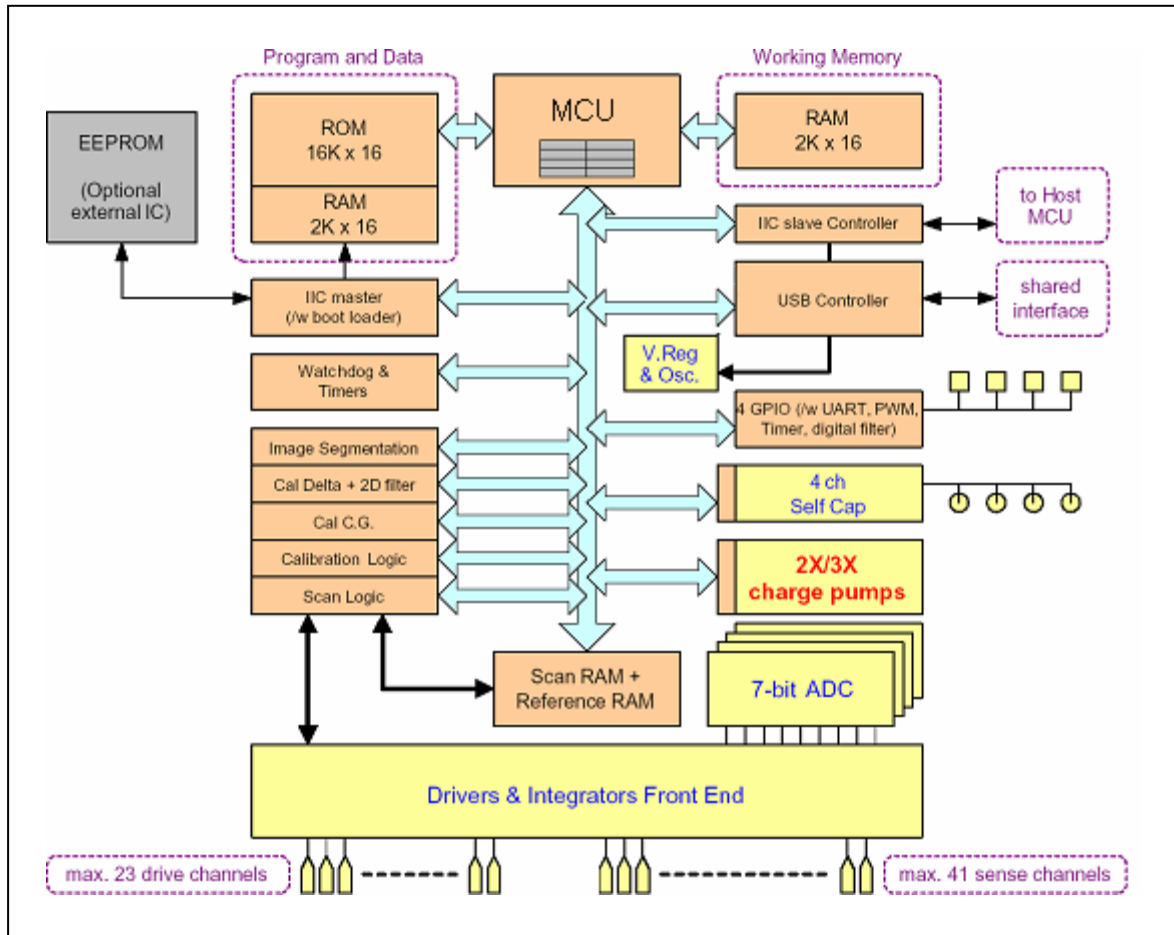

Figure 4-1: SSD2533 Block Diagram

5 PIN ARRANGEMENT

5.1 100 pins TQFP

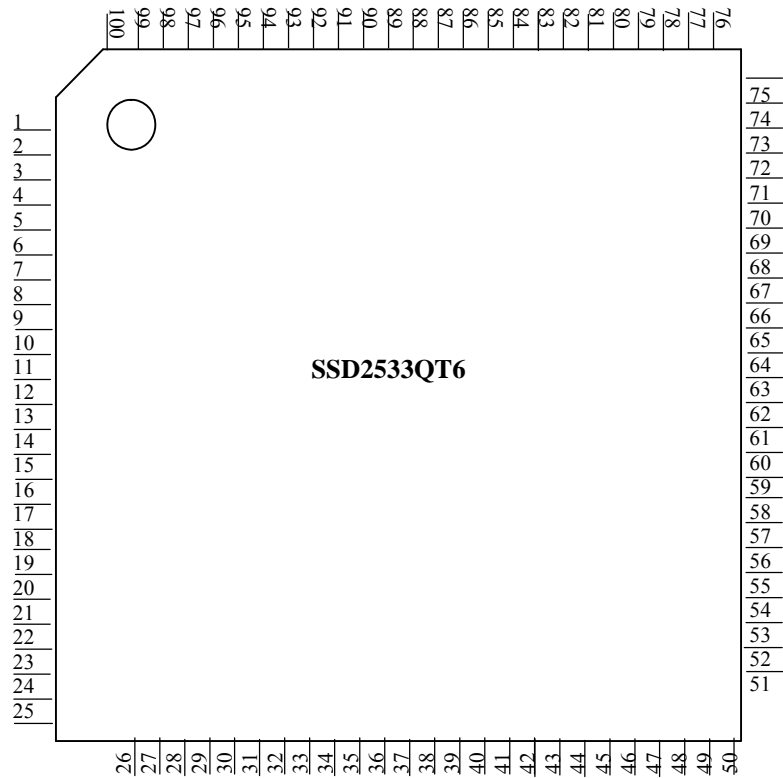

Figure 5-1: Pin-out Diagram – 100 pins TQFP (Top view)

Pin #	Signal Name	Pin #	Signal Name	Pin #	Signal Name	Pin #	Signal Name
1	AVSS	26	C3N	51	SENSE32	76	SENSE07
2	/RESET	27	C3P	52	SENSE31	77	SENSE06
3	/IRQ	28	VOUT	53	SENSE30	78	SENSE05
4	MASTER_SDA	29	VCHS	54	SENSE29	79	SENSE04
5	MASTER_SCK	30	DRIVE00	55	SENSE28	80	SENSE03
6	SLAVE_SDA	31	DRIVE01	56	SENSE27	81	SENSE02
7	SLAVE_SCK	32	DRIVE02	57	SENSE26	82	SENSE01
8	STYPE0	33	DRIVE03	58	SENSE25	83	SENSE00
9	STYPE1	34	DRIVE04	59	SENSE24	84	AVSS
10	KEY00	35	DRIVE05	60	SENSE23	85	VCI
11	KEY01	36	DRIVE06	61	SENSE22	86	DRIVE22
12	KEY02	37	DRIVE07	62	SENSE21	87	DRIVE21
13	KEY03	38	DRIVE08	63	SENSE20	88	DRIVE20
14	GPIO00	39	DRIVE09	64	SENSE19	89	DRIVE19
15	GPIO01	40	DRIVE10	65	SENSE18	90	DRIVE18
16	GPIO02	41	AVSS	66	SENSE17	91	DRIVE17
17	GPIO03	42	VCI	67	SENSE16	92	DRIVE16
18	DVSS	43	SENSE40	68	SENSE15	93	DRIVE15
19	VCORE	44	SENSE39	69	SENSE14	94	DRIVE14
20	VDDIO	45	SENSE38	70	SENSE13	95	DRIVE13
21	VCI	46	SENSE37	71	SENSE12	96	DRIVE12
22	BIAS	47	SENSE36	72	SENSE11	97	DRIVE11
23	AVSS	48	SENSE35	73	SENSE10	98	VCHS
24	C2P	49	SENSE34	74	SENSE09	99	USB_DP
25	C2N	50	SENSE33	75	SENSE08	100	USB_DN

Table 5-1 : 100 pins TQFP Pin Assignment Table

5.2 68 pins QFN

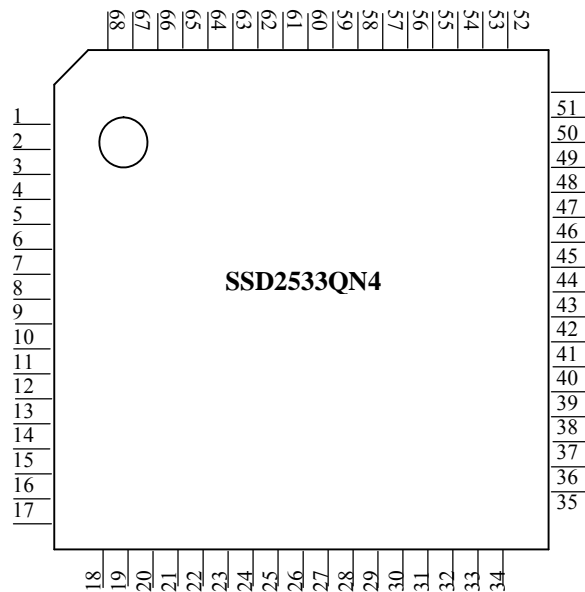

Figure 5-2: Pin-out Diagram – 68 pins QFN (Top view)

Pin #	Signal Name	Pin #	Signal Name	Pin #	Signal Name	Pin #	Signal Name
1	/IRQ	18	C3N	35	NC	52	AVSS
2	SLAVE_SDA	19	C3P	36	NC	53	DRIVE22
3	SLAVE_SCK	20	VOUT	37	NC	54	DRIVE21
4	STYPE	21	VCHS	38	SENSE20	55	DRIVE20
5	KEY00	22	DRIVE00	39	SENSE19	56	DRIVE19
6	KEY01	23	DRIVE01	40	SENSE18	57	DRIVE18
7	KEY02	24	DRIVE02	41	SENSE17	58	DRIVE17
8	KEY03	25	DRIVE03	42	SENSE16	59	DRIVE16
9	GPIO03	26	DRIVE04	43	SENSE15	60	DRIVE15
10	DVSS	27	DRIVE05	44	SENSE14	61	DRIVE14
11	VCORE	28	DRIVE06	45	SENSE13	62	DRIVE13
12	VDDIO	29	DRIVE07	46	SENSE12	63	DRIVE12
13	VCI	30	DRIVE08	47	SENSE11	64	DRIVE11
14	BIAS	31	DRIVE09	48	SENSE10	65	VCHS
15	AVSS	32	DRIVE10	49	SENSE09	66	USB_DP
16	C2P	33	AVSS	50	NC	67	USB_DN
17	C2N	34	NC	51	NC	68	/RESET

Table 5-2 : 68 pins QFN Pin Assignment Table for SSD2533QN4

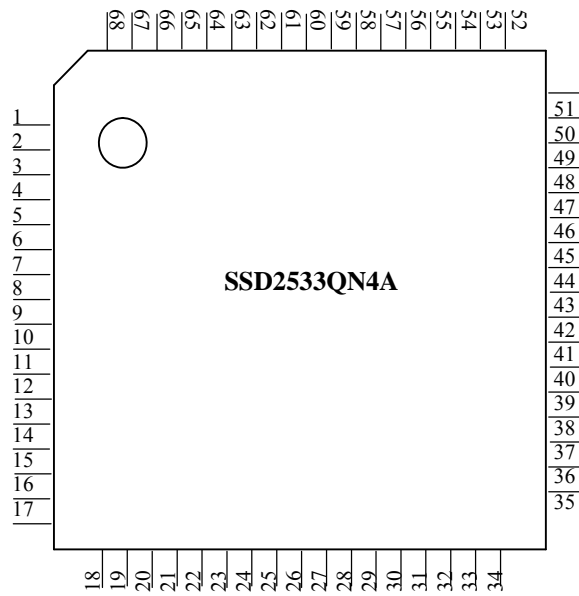

Figure 5-3: Pin-out Diagram – 68 pins QFN (Top view)

Pin #	Signal Name	Pin #	Signal Name	Pin #	Signal Name	Pin #	Signal Name
1	DRIVE<12>	18	C3N	35	SENSE<25>	52	SENSE<8>
2	DRIVE<11>	19	C3P	36	SENSE<24>	53	SENSE<7>
3	RESET_N	20	VOUT	37	SENSE<23>	54	SENSE<6>
4	IRQ	21	VCHS	38	SENSE<22>	55	SENSE<5>
5	SLAVE_SDA	22	DRIVE<0>	39	SENSE<21>	56	SENSE<4>
6	SLAVE_SCK	23	DRIVE<1>	40	SENSE<20>	57	SENSE<3>
7	KEY00	24	DRIVE<2>	41	SENSE<19>	58	SENSE<2>
8	KEY01	25	DRIVE<3>	42	SENSE<18>	59	SENSE<1>
9	KEY02	26	DRIVE<4>	43	SENSE<17>	60	SENSE<0>
10	KEY03	27	DRIVE<5>	44	SENSE<16>	61	DRIVE<20>
11	VCORE	28	DRIVE<6>	45	SENSE<15>	62	DRIVE<19>
12	VDDIO	29	DRIVE<7>	46	SENSE<14>	63	DRIVE<18>
13	VCI	30	DRIVE<8>	47	SENSE<13>	64	DRIVE<17>
14	BIAS	31	DRIVE<9>	48	SENSE<12>	65	DRIVE<16>
15	AVSS	32	DRIVE<10>	49	SENSE<11>	66	DRIVE<15>
16	C2P	33	SENSE<27>	50	SENSE<10>	67	DRIVE<14>
17	C2N	34	SENSE<26>	51	SENSE<9>	68	DRIVE<13>

Table 5-3 : 68 pins QFN Pin Assignment Table for SSD2533QN4A

5.3 88 pins QFN

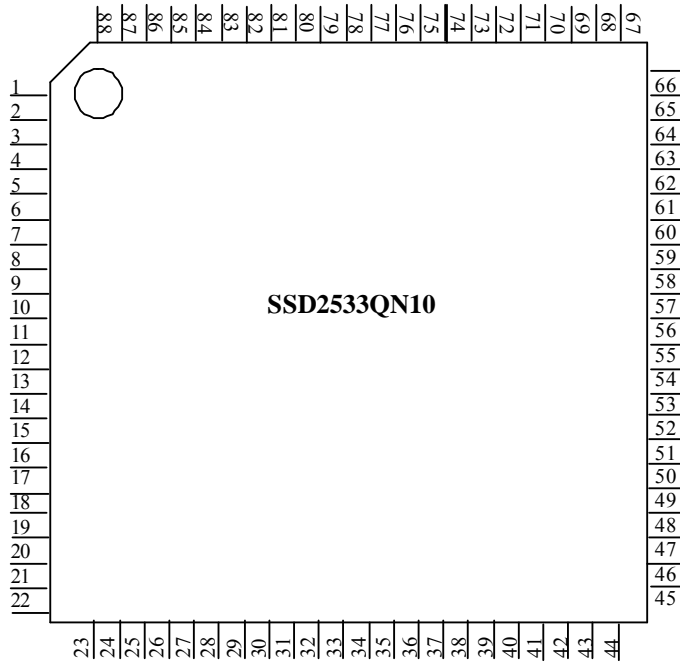

Figure 5-4: Pin-out Diagram – 88 pins QFN (Top view)

Pin #	Signal Name	Pin #	Signal Name	Pin #	Signal Name	Pin #	Signal Name
1	USB_DP	23	C2N	45	SENSE31	67	SENSE09
2	USB_DN	24	C3N	46	SENSE30	68	SENSE08
3	/RESET	25	C3P	47	SENSE29	69	SENSE07
4	/IRQ	26	VOUT	48	SENSE28	70	SENSE06
5	MASTER_SDA	27	VCHS	49	SENSE27	71	SENSE05
6	MASTER_SCK	28	DRIVE00	50	SENSE26	72	SENSE04
7	SLAVE_SDA	29	DRIVE01	51	SENSE25	73	SENSE03
8	SLAVE_SCK	30	DRIVE02	52	SENSE24	74	SENSE02
9	STYPE0	31	DRIVE03	53	SENSE23	75	SENSE01
10	STYPE1	32	DRIVE04	54	SENSE22	76	SENSE00
11	KEY00	33	DRIVE05	55	SENSE21	77	DRIVE22
12	KEY01	34	DRIVE06	56	SENSE20	78	DRIVE21
13	KEY02	35	DRIVE07	57	SENSE19	79	DRIVE20
14	KEY03	36	DRIVE08	58	SENSE18	80	DRIVE19
15	GPIO03	37	DRIVE09	59	SENSE17	81	DRIVE18
16	DVSS	38	DRIVE10	60	SENSE16	82	DRIVE17
17	VCORE	39	SENSE37	61	SENSE15	83	DRIVE16
18	VDDIO	40	SENSE36	62	SENSE14	84	DRIVE15
19	VCI	41	SENSE35	63	SENSE13	85	DRIVE14
20	BIAS	42	SENSE34	64	SENSE12	86	DRIVE13
21	AVSS	43	SENSE33	65	SENSE11	87	DRIVE12
22	C2P	44	SENSE32	66	SENSE10	88	DRIVE11

Table 5-4 : 88 pins QFN Pin Assignment Table

6 PIN DESCRIPTIONS

Key:

- I = Input
- O =Output
- IO = Bi-directional (input/output)
- P = Power pin
- Hi-Z = High impedance

6.1 Power

Pin Name	Type	RESET# State	Description
VDDIO	P	N/A	This pin is power supply input for I/O buffer
VCI	P	N/A	This pin is power supply input for analog circuit
VCHS	P	N/A	This pin is ground for Booster and HV switches
DVSS	P	N/A	This pin is ground for logic
AVSS	P	N/A	This pin is ground for analog

6.2 Logic

Pin Name	Type	RESET# State	Description																																								
/RESET	I	VDDIO	This is Reset pin for the chip																																								
/IRQ	O	VDDIO	This is Interrupt pin for Interrupt request																																								
SLAVE_SDA	IO	Hi-Z	IIC data pin																																								
SLAVE_SCK	I	Hi-Z	IIC clock input pin																																								
MASTER_SDA	IO	Hi-Z	IIC data pin in MCU mode																																								
MASTER_SCK	I	Hi-Z	IIC clock input pin in MCU mode																																								
STYPE0, STYPE1, GPIO3	I	Hi-Z	Bus interface mode selection pin.																																								
			<table border="1"> <thead> <tr> <th>STYPE1</th> <th>STYPE0</th> <th>GPIO3</th> <th>GPIO 2</th> <th>IIC Addr</th> </tr> </thead> <tbody> <tr> <td>0</td> <td>0</td> <td>GPIO</td> <td>GPIO</td> <td>0x48</td> </tr> <tr> <td>0</td> <td>1</td> <td>0</td> <td>Reserved</td> <td>Reserved</td> </tr> <tr> <td>0</td> <td>1</td> <td>1</td> <td>Reserved</td> <td>Reserved</td> </tr> <tr> <td>1</td> <td>0</td> <td>0</td> <td>Reserved</td> <td>Reserved</td> </tr> <tr> <td>1</td> <td>0</td> <td>1</td> <td>GPIO</td> <td>0x49</td> </tr> <tr> <td>1</td> <td>1</td> <td>0</td> <td>GPIO</td> <td>0x4A</td> </tr> <tr> <td>1</td> <td>1</td> <td>1</td> <td>GPIO</td> <td>0x4B</td> </tr> </tbody> </table>	STYPE1	STYPE0	GPIO3	GPIO 2	IIC Addr	0	0	GPIO	GPIO	0x48	0	1	0	Reserved	Reserved	0	1	1	Reserved	Reserved	1	0	0	Reserved	Reserved	1	0	1	GPIO	0x49	1	1	0	GPIO	0x4A	1	1	1	GPIO	0x4B
			STYPE1	STYPE0	GPIO3	GPIO 2	IIC Addr																																				
			0	0	GPIO	GPIO	0x48																																				
			0	1	0	Reserved	Reserved																																				
			0	1	1	Reserved	Reserved																																				
			1	0	0	Reserved	Reserved																																				
			1	0	1	GPIO	0x49																																				
1	1	0	GPIO	0x4A																																							
1	1	1	GPIO	0x4B																																							
USB_DP	IO	Hi-Z	USB data+ pin																																								
USB_DN	IO	Hi-Z	USB data- pin																																								

6.3 Analog

Pin Name	Type	RESET# State	Description
C2P	IO	VCI/VCHS	Booster pin. Connect a capacitor to C2N
C2N	IO	VCI/VCHS	Booster pin. Connect a capacitor to C2P
C3P	IO	VCI/VCHS	Booster pin. Connect a capacitor to C3N
C3N	IO	VCI/VCHS	Booster pin. Connect a capacitor to C3P
VOUT	P	VCI/VCHS	Output power supply for booster. Connect a capacitor for stabilization
BIAS	P	VCI/VCHS	Regulated voltage supply for sensor circuit. Connect a capacitor for stabilization
VCORE	P	N/A	Regulated voltage supply for logic circuit. Connect a capacitor for stabilization

6.4 Input and Output

Pin Name	Type	RESET# State	Description
SENSE00 – SENSE40	I	Hi-Z	Sensor input pins
DRIVE00 – DRIVE22	O	VCHS	Driver output pins
KEY00 – KEY03	I	Hi-Z	Self-cap input pins
GPIO00 – GPIO03	I	Hi-Z	GPIO pins

7 FUNCTIONAL BLOCK DESCRIPTIONS

7.1 STYPE0, STYPE1, GPIO3

In SSD2533, the addresses for IIC interface are listed as below.

STYPE 1	STYPE 0	GPIO 3	GPIO 2	IIC Address
0	0	GPIO	GPIO	0x48
0	1	0	Reserved	Reserved
0	1	1	Reserved	Reserved
1	0	0	Reserved	Reserved
1	0	1	GPIO	0x49
1	1	0	GPIO	0x4A
1	1	1	GPIO	0x4B

7.2 MCU

This block is a 16bit MCU core

7.3 ADC

This block is an analog to digital converter for converting the sensing signal to digital data.

7.4 Analog Booster circuit

This block generates the high output driving voltage for the driving pins.

7.5 IIC interface (Master/Slave)

This block is used to communicate with the MCU.

It supports the mandatory slave feature showed below.

- START Condition
- STOP Condition
- Acknowledge

With the addition of 16-bit MCU, system flow control has been changed from hardware logic to firmware code.

Support EEPROM with IIC boot loader.

7.6 41 pins Sensing input

This block is the sensing circuit.

7.7 23 pins driving Output Amplifier

This block is the driving output circuit.

7.8 4 pins Self-cap input

This block is the self cap circuit.

8 COMMAND TABLE

Reg No. Hex	Reg No. Dec	Name	Function	Read/Wr ite/Com mand	Byte of paramete r	Parameter	Default
0x00	0	NOP	No operation	C	0		N/A
0x02	2	DEVICE_ID	Read Device ID	R	2	[15:0]: report "2533"	0x2533
0x04	4	SLEEP_OUT_REG (wake up)	System go to Idle Mode	C	0		N/A
0x05	5	SLEEP_IN_REG (go to sleep)	System go to Sleep Mode.	C	0		N/A
0x06	6	DRIVE_NO_REG	Set No# of Driving Electrode	W	1	[7:5]: Reserved [4:0]: Number of Drive line - 1	0x16
0x07	7	SENSE_NO_REG	Set No# of Sensing Electrode	W	1	[7:6]: Reserved [5:0]: Number of Sense line - 1	0x28
0x08	8	DRIVE_LINE0_REG	Select Drive pin, slew rate and group (left/right side of panel)	W	2	[8]: Drive line group (left/right) [7:5]: Reserved [4:0]: Drive pin select	0x0000
0x09	9	DRIVE_LINE1_REG	Select Drive pin, slew rate and group (left/right side of panel)	W	2	[8]: Drive line group (left/right) [7:5]: Reserved [4:0]: Drive pin select	0x0001
0x0A	10	DRIVE_LINE2_REG	Select Drive pin, slew rate and group (left/right side of panel)	W	2	[8]: Drive line group (left/right) [7:5]: Reserved [4:0]: Drive pin select	0x0002
0x0B	11	DRIVE_LINE3_REG	Select Drive pin, slew rate and group (left/right side of panel)	W	2	[8]: Drive line group (left/right) [7:5]: Reserved [4:0]: Drive pin select	0x0003
0x0C	12	DRIVE_LINE4_REG	Select Drive pin, slew rate and group (left/right side of panel)	W	2	[8]: Drive line group (left/right) [7:5]: Reserved [4:0]: Drive pin select	0x0004
0x0D	13	DRIVE_LINE5_REG	Select Drive pin, slew rate and group (left/right side of panel)	W	2	[8]: Drive line group (left/right) [7:5]: Reserved [4:0]: Drive pin select	0x0005
0x0E	14	DRIVE_LINE6_REG	Select Drive pin, slew rate and group (left/right side of panel)	W	2	[8]: Drive line group (left/right) [7:5]: Reserved [4:0]: Drive pin select	0x0006
0x0F	15	DRIVE_LINE7_REG	Select Drive pin, slew rate and group (left/right side of panel)	W	2	[8]: Drive line group (left/right) [7:5]: Reserved [4:0]: Drive pin select	0x0007
0x10	16	DRIVE_LINE8_REG	Select Drive pin, slew rate and group (left/right side of panel)	W	2	[8]: Drive line group (left/right) [7:5]: Reserved [4:0]: Drive pin select	0x0008

0x11	17	DRIVE_LINE9_REG	Select Drive pin, slew rate and group (left/right side of panel)	W	2	[8]: Drive line group (left/right) [7:5]: Reserved [4:0]: Drive pin select	0x0009
0x12	18	DRIVE_LINE10_REG	Select Drive pin, slew rate and group (left/right side of panel)	W	2	[8]: Drive line group (left/right) [7:5]: Reserved [4:0]: Drive pin select	0x000A
0x13	19	DRIVE_LINE11_REG	Select Drive pin, slew rate and group (left/right side of panel)	W	2	[8]: Drive line group (left/right) [7:5]: Reserved [4:0]: Drive pin select	0x010B
0x14	20	DRIVE_LINE12_REG	Select Drive pin, slew rate and group (left/right side of panel)	W	2	[8]: Drive line group (left/right) [7:5]: Reserved [4:0]: Drive pin select	0x010C
0x15	21	DRIVE_LINE13_REG	Select Drive pin, slew rate and group (left/right side of panel)	W	2	[8]: Drive line group (left/right) [7:5]: Reserved [4:0]: Drive pin select	0x010D
0x16	22	DRIVE_LINE14_REG	Select Drive pin, slew rate and group (left/right side of panel)	W	2	[8]: Drive line group (left/right) [7:5]: Reserved [4:0]: Drive pin select	0x010E
0x17	23	DRIVE_LINE15_REG	Select Drive pin, slew rate and group (left/right side of panel)	W	2	[8]: Drive line group (left/right) [7:5]: Reserved [4:0]: Drive pin select	0x010F
0x18	24	DRIVE_LINE16_REG	Select Drive pin, slew rate and group (left/right side of panel)	W	2	[8]: Drive line group (left/right) [7:5]: Reserved [4:0]: Drive pin select	0x0110
0x19	25	DRIVE_LINE17_REG	Select Drive pin, slew rate and group (left/right side of panel)	W	2	[8]: Drive line group (left/right) [7:5]: Reserved [4:0]: Drive pin select	0x0111
0x1A	26	DRIVE_LINE18_REG	Select Drive pin, slew rate and group (left/right side of panel)	W	2	[8]: Drive line group (left/right) [7:5]: Reserved [4:0]: Drive pin select	0x0112
0x1B	27	DRIVE_LINE19_REG	Select Drive pin, slew rate and group (left/right side of panel)	W	2	[8]: Drive line group (left/right) [7:5]: Reserved [4:0]: Drive pin select	0x0113
0x1C	28	DRIVE_LINE20_REG	Select Drive pin, slew rate and group (left/right side of panel)	W	2	[8]: Drive line group (left/right) [7:5]: Reserved [4:0]: Drive pin select	0x0114
0x1D	29	DRIVE_LINE21_REG	Select Drive pin, slew rate and group (left/right side of panel)	W	2	[8]: Drive line group (left/right) [7:5]: Reserved [4:0]: Drive pin select	0x0115

0x1E	30	DRIVE_LINE22_REG	Select Drive pin, slew rate and group (left/right side of panel)	W	2	[8]: Drive line group (left/right) [7:5]: Reserved [4:0]: Drive pin select	0x0116
0x25	37	WOP_MODE_REG	Set Operating Mode	W	1	[7:0]: Frame scan period in millisecond + 3 0x00 to enter IDLE mode.	0x00
0x26	38	ROP_MODE_REG	Read Operating Mode	R	1	Ditto	0x00
0x27	39	DOWN_TIME_REG	Set Power Down Time	W	1	[7:0]: Set Down Time in milliseconds + 4	0x64
0x28	40	FRAME_ESC_REG	Set Frame Escape Number	W	1	[7:0]: (Frame Escape No#) / 2	0x5A
0x2A	42	SCAN_FRAME_REG	Set No# of Sub Frame	W	1	[7:4]: Reserved [2:0]: No# of sub-frame per frame - 1	0x01
0x2C	44	MEDIAN_FILTER_SEL_REG	Enable/Disable median filter for sampled data	W	1	[7:1] Reserved [0]: '0' = disable '1' = enable	0x00
0x2F	47	INT_GAIN_REG (BP_CYCLE)	Set integration gain	W	1	[2:0]: gain - 1	0x02
0x30	48	START_INT_REG	Set the start time of integration window	W	1	[3:0]: start time in unit of 125ns.	0x01
0x31	49	END_INT_REG	Set the end time of integration window	W	1	[3:0] end time in unit of 125ns.	0x04
0x33	51	MIN_AREA_REG	Define Min. Finger Area	W	2	[7:0]: Min. area for a valid finger detection	0x0002
0x34	52	MIN_LEVEL_REG	Define Min. Finger Level	W	2	[8:0]: Min. amplitude for a valid finger detection	0x0040
0x35	53	MIN_WEIGHT_REG	Define Min. Finger Weight	W	2	[15:0]: Min. weight threshold for a valid finger detection	0x00FF
0x36	54	MAX_AREA_REG	Define Max. Finger Area	W	2	[7:0]: Max. area for a valid finger detection	0x0018
0x37	55	SEG_DEPTH_REG	Set slicing depth in image segmentation process	W	1	[7:2]: Reserved [2:0]: 0 = 82% 1 = 78% 2 = 73% 3 = 68% 4 = 63% 5 = 56% 6 = 49% 7 = 41%	0x04
0x39	57	CG_METHOD_REG	Select finger CG calculation method	W	1	[1:0]: 0 = Weighted average 1 = Curve fitting 2 = Hybrid	0x02
0x3A	58	HYBRID_SELECT_REG	Select blending % in hybrid CG calculation.	W	1	[7:2]: Reserved [1:0]: Weighted Curve Average Fitting 00 = 50% 50% 01 = 75% 25% 10 = 25% 75% 11 = Reserved	0x00
0x3C	60	INT_BYPASS_REG	Bypass init sequence when go from Idel Mode to Operating Mode.	W	1	[0]: 0 = normal init sequence 1 = bypass init sequence	0x00

0x3D	61	FILTER_SEL_REG	Select 2D filter parameter for delta data smoothing	W	1	[7:2]: Reserved [1:0]: 0: 1-6-1 filter 1: 1-2-1 filter 2: no filter	0x00
0x3E	62	CALIBRATE_OFF_REG	Switch off auto calibration	W	1	[7:1]: Reserved [0]: 0: auto calibration ON 1: auto calibration OFF	0x00
0x53	83	EVENT_MOVE_TOL_REG	Set MOVE tolerance	W	1	[7:0]: MOVE tolerance in basic resolution unit	0x0A
0x54	84	X_TRACKING_TOL_REG	Set X Tracking Tolerance	W	2	[8:0]: X tracking tolerance in basic resolution unit	0x0080
0x55	85	Y_TRACKING_TOL_REG	Set Y Tracking Tolerance	W	2	[8:0]: Y tracking tolerance in basic resolution unit	0x0080
0x56	86	MOV_AVG_FILTER_REG	Enable moving average filter to smooth fingers output coordinates.	W	1	[7:1]: Reserved [1:0]: 00 = disable filter 01 = enable filter 5:3 10 = enable filter 6:2 11 = enable filter 7:1	0x02
0x65	101	ORIENTATION_REG	Remap finger coordinates according to different orientation	W	1	[7:3]: Reserved [2:0]: 000: Mormal 001: Y-Invert 010: X-Invert 011: X-Invert + Y-Invert 100: Transpose 101: Transpoe + X-Invert (270 deg) 110: Transpose + Y-Invert (90 deg) 111: Transpose + X-Invert + Y-Invert	0x00
0x66	102	X_SCALING_REG	Set scaling factor for X coordinate.	W	2	[15:0]: X scaling factor in 0.#####0000 binary format.	0xFFFF0
0x67	103	Y_SCALING_REG	Set scaling factor for Y coordinate.	W	2	[15:0]: Y scaling factor in 0.#####0000 binary format.	0xFFFF0
0x68	104	X_OFFSET_REG	Offset in X direction	W	1	[7]: Reserved [6:0]: X offset in basic resolution unit	0x00
0x69	105	Y_OFFSET_REG	Offset in Y direction	W	1	[7]: Reserved [6:0]: Y offset in basic resolution unit	0x00
0x79	121	TOUCH_STATUS	Touch Status	R	2	[15:14]: reserved [13]: Finger09 detected [12]: Finger08 detected [11]: Finger07 detected [10]: Finger06 detected [9]: Finger05 detected [8]: Finger04 detected [7]: Finger03 detected [6]: Finger02 detected [5]: Finger01 detected [4]: Finger00 detected [3]: Abnormal status detected [2]: Large Object detected [1]: FIFO overflow [0]: FIFO data valid	0x0000

0x7A	122	EVENT_MSK_REG	Event Mask	W	2	[15]: Unknown Event mask [14:8]: Reserved [7]: Must set to 1 [6]: Must set to 1 [5]: FL Event mask [4]: FM Event mask [3]: FE Event mask [2]: Must set to 1 [1]: Must set to 1 [0]: Must set to 1	0xFFC7
0x7B	123	IRQ_MSK_REG	IRQ Mask	W	2	[15:14]: reserved [13]: Finger09 status mask [12]: Finger08 status mask [11]: Finger07 status mask [10]: Finger06 status mask [9]: Finger05 status mask [8]: Finger04 status mask [7]: Finger03 status mask [6]: Finger02 status mask [5]: Finger01 status mask [4]: Finger00 status mask [3]: Abnormal status mask [2]: Large Object status mask [1]: FIFO overflow status mask [0]: FIFO data valid status mask	0x0000
0x7C	124	FINGER00_REG	Finger00 Coordinate	R	4	[31:24]: X-coordinate[7:0] [23:16]: Y-coordinate[7:0] [15:12]: X-coordinate [11:8] [11:8]: Y-coordinate [11:8] [7:4]: Pressure Index [3:0]: Speed Index	0xFF 0xFF 0xFF 0x00
0x7D	125	FINGER01_REG	Finger01 Coordinate	R	4	[31:24]: X-coordinate[7:0] [23:16]: Y-coordinate[7:0] [15:12]: X-coordinate [11:8] [11:8]: Y-coordinate [11:8] [7:4]: Pressure Index [3:0]: Speed Index	0xFF 0xFF 0xFF 0x00
0x7E	126	FINGER02_REG	Finger02 Coordinate	R	4	[31:24]: X-coordinate[7:0] [23:16]: Y-coordinate[7:0] [15:12]: X-coordinate [11:8] [11:8]: Y-coordinate [11:8] [7:4]: Pressure Index [3:0]: Speed Index	0xFF 0xFF 0xFF 0x00
0x7F	127	FINGER03_REG	Finger03 Coordinate	R	4	[31:24]: X-coordinate[7:0] [23:16]: Y-coordinate[7:0] [15:12]: X-coordinate [11:8] [11:8]: Y-coordinate [11:8] [7:4]: Pressure Index [3:0]: Speed Index	0xFF 0xFF 0xFF 0x00

0x80	128	FINGER04_REG	Finger04 Coordinate	R	4	[31:24]: X-coordinate[7:0] [23:16]:Y-coordinate[7:0] [15:12]: X-coordinate [11:8] [11:8]: Y-coordinate [11:8] [7:4]: Pressure Index [3:0]: Speed Index	0xFF 0xFF 0xFF 0x00
0x81	129	FINGER05_REG	Finger05 Coordinate	R	4	[31:24]: X-coordinate[7:0] [23:16]:Y-coordinate[7:0] [15:12]: X-coordinate [11:8] [11:8]: Y-coordinate [11:8] [7:4]: Pressure Index [3:0]: Speed Index	0xFF 0xFF 0xFF 0x00
0x82	130	FINGER06_REG	Finger06 Coordinate	R	4	[31:24]: X-coordinate[7:0] [23:16]:Y-coordinate[7:0] [15:12]: X-coordinate [11:8] [11:8]: Y-coordinate [11:8] [7:4]: Pressure Index [3:0]: Speed Index	0xFF 0xFF 0xFF 0x00
0x83	131	FINGER07_REG	Finger07 Coordinate	R	4	[31:24]: X-coordinate[7:0] [23:16]:Y-coordinate[7:0] [15:12]: X-coordinate [11:8] [11:8]: Y-coordinate [11:8] [7:4]: Pressure Index [3:0]: Speed Index	0xFF 0xFF 0xFF 0x00
0x84	132	FINGER08_REG	Finger08 Coordinate	R	4	[31:24]: X-coordinate[7:0] [23:16]:Y-coordinate[7:0] [15:12]: X-coordinate [11:8] [11:8]: Y-coordinate [11:8] [7:4]: Pressure Index [3:0]: Speed Index	0xFF 0xFF 0xFF 0x00
0x85	133	FINGER09_REG	Finger09 Coordinate	R	4	[31:24]: X-coordinate[7:0] [23:16]:Y-coordinate[7:0] [15:12]: X-coordinate [11:8] [11:8]: Y-coordinate [11:8] [7:4]: Pressure Index [3:0]: Speed Index	0xFF 0xFF 0xFF 0x00
0x86	134	EVENT_STACK	Read one event from the Event Stack	R	5	[39:36]: Finger number [35:32]: Event number [31:24]: X-coordinate[7:0] [23:16]:Y-coordinate[7:0] [15:12]: X-coordinate [11:8] [11:8]: Y-coordinate [11:8] [7:4]: pressure [3:0]: speed	0x00 0xFF 0xFF 0xFF 0x00
0x87	135	EVENT_FIFO_SCLR	Clear Event Stack	W	1	[7:1]: reserved [0]: set '1' to clear event fifo	N/A
0xA2	162	INIT_RST	Reset Init Reference Procedure	W	1	Dummy Byte For example 0x00 can be sent from I2C master. Write once to activate the init reference procedure again	N/A

0xD5	213	DRIVE_LEVEL_REG	Select Driving voltage	W	1	[7:3]: Reserved [2:0]: 0 = 5.5V 1 = 6.0V 2 = 6.5V 3 = 7.0V 4 = 7.5V 5 = 8.0V 6 = 8.5V 7 = 9.0V	0x03
0xD7	215	ADC_RANGE_SEL_REG	Select ADC Vref range	W	1	VrefH VrefL [2:0]: 000: VCI/2 + 0.35 VCI/2 - 0.35 001: VCI/2 + 0.40 VCI/2 - 0.40 010: VCI/2 + 0.45 VCI/2 - 0.45 011: VCI/2 + 0.50 VCI/2 - 0.50 100: VCI/2 + 0.60 VCI/2 - 0.60 101: VCI/2 + 0.70 VCI/2 - 0.70 110: VCI/2 + 0.80 VCI/2 - 0.80 111: VCI/2 + 0.90 VCI/2 - 0.90	0x04
0xD8	216	BIAS_RES	Select Sense line biasing resistance	W	1	[2:0]: 0 = 7.0k 1 = 7.8k 2 = 8.7k 3 = 9.7k 4 = 10.8k 5 = 12.1k 6 = 13.5k 7 = 15.0k	0x04
0xDB	219	INTG_CAP_REG	Set integrator cap value	W	1	[2]: CI2 [1]: CI1 [0]: CI0	0x00

9 COMMAND DESCRIPTIONS

No Operation (R00h)

No Operation for this command.

Read Device ID Register (R02h)

R/W	Parameter	IB7	IB6	IB5	IB4	IB3	IB2	IB1	IB0
R	1	0	0	1	0	0	1	0	1
R	2	0	0	1	1	0	0	1	1
POR		0	0	1	0	0	1	0	1
POR		0	0	1	1	0	0	1	1

This register returned the Device ID “2533h”.

System Enable (R04h)

A dummy byte (e.g. 0x00) should be sent after this command to enable the system clock.

System Disable (R05h)

A dummy byte (e.g. 0x00) should be sent after this command to disable the system clock.

Drive Line Number Register (R06h)

R/W	Parameter	IB7	IB6	IB5	IB4	IB3	IB2	IB1	IB0
W	1	--	--	--	Drive_No				
POR		0	0	0	1	0	1	1	0

The number of driving lines can be set up to maximum 23.

Drive_No	Number of Driving Lines
00000	1
00001	2
:	:
:	Step = 1
:	:
10101	22
10110	23 (default)

Sense Line Number Register (R07h)

R/W	Parameter	IB7	IB6	IB5	IB4	IB3	IB2	IB1	IB0
W	1	--	--	Sense_No					
POR		0	0	1	0	1	0	0	0

The number of sensing lines can be set up to maximum 41.

Sense_No	Number of Sensing Lines
000000	1
000001	2
:	:
:	Step = 1
:	:
100111	40
101000	41 (default)

Select Drive Pin for 1st Drive Line (R08h)

R/W	Parameter	IB7	IB6	IB5	IB4	IB3	IB2	IB1	IB0
W	1	--							Group
W	2	--			Drive pin selection				
POR		0	0	0	0	0	0	0	0
POR		0	0	0	0	0	0	0	0

Select Drive Pin for 2nd Drive Line (R09h)

R/W	Parameter	IB7	IB6	IB5	IB4	IB3	IB2	IB1	IB0
W	1	--							Group
W	2	--			Drive pin selection				
POR		0	0	0	0	0	0	0	0
POR		0	0	0	0	0	0	0	1

Select Drive Pin for 3rd Drive Line (R0Ah)

R/W	Parameter	IB7	IB6	IB5	IB4	IB3	IB2	IB1	IB0
W	1	--							Group
W	2	--			Drive pin selection				
POR		0	0	0	0	0	0	0	0
POR		0	0	0	0	0	0	1	0

Select Drive Pin for 4th Drive Line (R0Bh)

R/W	Parameter	IB7	IB6	IB5	IB4	IB3	IB2	IB1	IB0
W	1	--							Group
W	2	--			Drive pin selection				
POR		0	0	0	0	0	0	0	0
POR		0	0	0	0	0	0	1	1

Select Drive Pin for 5th Drive Line (R0Ch)

R/W	Parameter	IB7	IB6	IB5	IB4	IB3	IB2	IB1	IB0
W	1	--							Group
W	2	--			Drive pin selection				
POR		0	0	0	0	0	0	0	0
POR		0	0	0	0	0	1	0	0

Select Drive Pin for 6th Drive Line (R0Dh)

R/W	Parameter	IB7	IB6	IB5	IB4	IB3	IB2	IB1	IB0
W	1	--							Group
W	2	--			Drive pin selection				
POR		0	0	0	0	0	0	0	0
POR		0	0	0	0	0	1	0	1

Select Drive Pin for 7th Drive Line (R0Eh)

R/W	Parameter	IB7	IB6	IB5	IB4	IB3	IB2	IB1	IB0
W	1	--							Group
W	2	--			Drive pin selection				
POR		0	0	0	0	0	0	0	0
POR		0	0	0	0	0	1	1	0

Select Drive Pin for 8th Drive Line (R0Fh)

R/W	Parameter	IB7	IB6	IB5	IB4	IB3	IB2	IB1	IB0
W	1	--							Group
W	2	--			Drive pin selection				
POR		0	0	0	0	0	0	0	0
POR		0	0	0	0	0	1	1	1

Select Drive Pin for 9th Drive Line (R10h)

R/W	Parameter	IB7	IB6	IB5	IB4	IB3	IB2	IB1	IB0
W	1	--							Group
W	2	--			Drive pin selection				
	POR	0	0	0	0	0	0	0	0
	POR	0	0	0	0	1	0	0	0

Select Drive Pin for 10th Drive Line (R11h)

R/W	Parameter	IB7	IB6	IB5	IB4	IB3	IB2	IB1	IB0
W	1	--							Group
W	2	--			Drive pin selection				
	POR	0	0	0	0	0	0	0	0
	POR	0	0	0	0	1	0	0	1

Select Drive Pin for 11th Drive Line (R12h)

R/W	Parameter	IB7	IB6	IB5	IB4	IB3	IB2	IB1	IB0
W	1	--							Group
W	2	--			Drive pin selection				
	POR	0	0	0	0	0	0	0	0
	POR	0	0	0	0	1	0	1	0

Select Drive Pin for 12th Drive Line (R13h)

R/W	Parameter	IB7	IB6	IB5	IB4	IB3	IB2	IB1	IB0
W	1	--							Group
W	2	--			Drive pin selection				
	POR	0	0	0	0	0	0	0	1
	POR	0	0	0	0	1	0	1	1

Select Drive Pin for 13th Drive Line (R14h)

R/W	Parameter	IB7	IB6	IB5	IB4	IB3	IB2	IB1	IB0
W	1	--							Group
W	2	--			Drive pin selection				
	POR	0	0	0	0	0	0	0	1
	POR	0	0	0	0	1	1	0	0

Select Drive Pin for 14th Drive Line (R15h)

R/W	Parameter	IB7	IB6	IB5	IB4	IB3	IB2	IB1	IB0
W	1	--							Group
W	2	--			Drive pin selection				
	POR	0	0	0	0	0	0	0	1
	POR	0	0	0	0	1	1	0	1

Select Drive Pin for 15th Drive Line (R16h)

R/W	Parameter	IB7	IB6	IB5	IB4	IB3	IB2	IB1	IB0
W	1	--							Group
W	2	--			Drive pin selection				
	POR	0	0	0	0	0	0	0	1
	POR	0	0	0	0	1	1	1	0

Select Drive Pin for 16th Drive Line (R17h)

R/W	Parameter	IB7	IB6	IB5	IB4	IB3	IB2	IB1	IB0
W	1	--							Group
W	2	--			Drive pin selection				
	POR	0	0	0	0	0	0	0	1
	POR	0	0	0	0	1	1	1	1

Select Drive Pin for 17th Drive Line (R18h)

R/W	Parameter	IB7	IB6	IB5	IB4	IB3	IB2	IB1	IB0
W	1	--							Group
W	2	--			Drive pin selection				
	POR	0	0	0	0	0	0	0	1
	POR	0	0	0	1	0	0	0	0

Select Drive Pin for 18th Drive Line (R19h)

R/W	Parameter	IB7	IB6	IB5	IB4	IB3	IB2	IB1	IB0
W	1	--							Group
W	2	--			Drive pin selection				
	POR	0	0	0	0	0	0	0	1
	POR	0	0	0	1	0	0	0	1

Select Drive Pin for 19th Drive Line (R1Ah)

R/W	Parameter	IB7	IB6	IB5	IB4	IB3	IB2	IB1	IB0
W	1	--							Group
W	2	--			Drive pin selection				
	POR	0	0	0	0	0	0	0	1
	POR	0	0	0	1	0	0	1	0

Select Drive Pin for 20th Drive Line (R1Bh)

R/W	Parameter	IB7	IB6	IB5	IB4	IB3	IB2	IB1	IB0
W	1	--							Group
W	2	--			Drive pin selection				
	POR	0	0	0	0	0	0	0	1
	POR	0	0	0	1	0	0	1	1

Select Drive Pin for 21st Drive Line (R1Ch)

R/W	Parameter	IB7	IB6	IB5	IB4	IB3	IB2	IB1	IB0
W	1	--							Group
W	2	--			Drive pin selection				
	POR	0	0	0	0	0	0	0	1
	POR	0	0	0	1	0	1	0	0

Select Drive Pin for 22nd Drive Line (R1Dh)

R/W	Parameter	IB7	IB6	IB5	IB4	IB3	IB2	IB1	IB0
W	1	--							Group
W	2	--			Drive pin selection				
	POR	0	0	0	0	0	0	0	1
	POR	0	0	0	1	0	1	0	1

Select Drive Pin for 23rd Drive Line (R1Eh)

R/W	Parameter	IB7	IB6	IB5	IB4	IB3	IB2	IB1	IB0
W	1	--							Group
W	2	--			Drive pin selection				
	POR	0	0	0	0	0	0	0	1
	POR	0	0	0	1	0	1	1	0

Write Operation Mode (R25h)

R/W	Parameter	IB7	IB6	IB5	IB4	IB3	IB2	IB1	IB0
W	1	--	--	--	--	Op_Mode			
	POR	0	0	0	0	0	0	0	0

Idle Mode - In Idle Mode, no scanning activities will be performed. The analog block will be powered down always.

Slow Scan Mode - In Slow Scan Mode, the scan rate is dropped to 0~48Hz. This mode is suitable for mobile applications and GUI applications in most cases.

Normal Scan Mode - In Normal Scan Mode, the frame scan rate is 50~91Hz. This mode is good enough for simple handwriting and gesture. This mode is also recommended for mobile application.

Fast Scan Mode - In Fast Scan Mode, the frame scan rate is 100~1000Hz. This mode can be used for application like high speed sketching and detailed drawing.

Read Operation Mode (R26h)

R/W	Parameter	IB7	IB6	IB5	IB4	IB3	IB2	IB1	IB0
R	1	--	--	--	--	Op_Mode			
POR		0	0	0	0	0	0	0	0

To clarify the existing operation mode of SSD2533, user can read R_Mode from register address R26h. The value of R_Op_Mode indicates the latest operation mode setting written by Operation Mode Setting Register.

Power Down Time Setting Register (R27h)

R/W	Parameter	IB7	IB6	IB5	IB4	IB3	IB2	IB1	IB0
W	1	Down_Time							
POR		0	1	1	0	0	1	0	0

Frame Esc Timing Register (R28h)

R/W	Parameter	IB7	IB6	IB5	IB4	IB3	IB2	IB1	IB0
W	1	--	--	--	--	Esc_Time			
POR		0	1	0	1	1	0	1	0

This register defined the time period for the system to enter power saving mode. If the system detected there has no finger touch on the panel, the internal timer will start counting down until reaching the value of Esc_Time or a finger touch is present.

Number of Sub Frames Per Frame Scan (R2Ah)

R/W	Parameter	IB7	IB6	IB5	IB4	IB3	IB2	IB1	IB0
W	1	--	--	--	--	--	Sub_frame		
POR		0	0	0	0	0	0	0	1

This register defined the sensitivity level by the sampling rate. The range of the sub-frame is 1 to 7.

Median Filter Setting (R2Ch)

R/W	Parameter	IB7	IB6	IB5	IB4	IB3	IB2	IB1	IB0
W	1	--	--	--	--	--	--	--	Median_Filter
POR		0	0	0	0	0	0	0	0

Median_Filter = '0' disable the filter, '1' enable the filter
Recommended to set '1' to turn on the filter for filtering TFT noise.

Integration Gain Setting (R2Fh)

R/W	Parameter	IB7	IB6	IB5	IB4	IB3	IB2	IB1	IB0
W	1	--	--	--	--	--	Gain		
POR		0	0	0	0	0	0	1	0

This register set the gain of the integrator. The range of the gain is 1 to 4.

Start Time of Integration Window Setting (R30h)

R/W	Parameter	IB7	IB6	IB5	IB4	IB3	IB2	IB1	IB0
W	1	--	--	--	--	Start_Time			
POR		0	0	0	0	0	0	0	1

This register set the start time of the integration window in unit of 125ns.

End Time of Integration Window Setting (R31h)

R/W	Parameter	IB7	IB6	IB5	IB4	IB3	IB2	IB1	IB0
W	1	--	--	--	--	End_Time			
POR		0	0	0	0	0	1	0	0

This register set the end time of the integration window in unit of 125ns. The setting of end time must bigger than start time (R30h)

Min Finger Area Setting Register (R33h)

R/W	Parameter	IB7	IB6	IB5	IB4	IB3	IB2	IB1	IB0
W	1	--	--	--	--	--	--	--	--
W	2	Min_Area							
POR		0	0	0	0	0	0	1	0

If the touching area detected is bigger than Min_Area, the system will report “valid finger”

Min Finger Level Setting Register (R34h)

R/W	Parameter	IB7	IB6	IB5	IB4	IB3	IB2	IB1	IB0
W	1	--	--	--	--	--	--	--	--
W	2	Min_Level							
POR		0	1	0	0	0	0	0	0

If the touching level detected is bigger than Min_Level, the system will report “valid finger”

Min Finger Weight Setting Register (R35h)

R/W	Parameter	IB7	IB6	IB5	IB4	IB3	IB2	IB1	IB0
W	1	Min_Weight							
W	2	Min_Weight							
POR		0	0	0	0	0	0	0	0
POR		1	1	1	1	1	1	1	1

Similar to Min Finger Area, user can define also the weight of a valid finger touch. Weight means the summation of the signal level within the touch area.

Weight is as a function of finger area (R33h) and finger level (R34h)

Max Finger Area Setting Register (R36h)

R/W	Parameter	IB7	IB6	IB5	IB4	IB3	IB2	IB1	IB0
W	1	--	--	--	--	--	--	--	--
W	2	Max_Area							
POR		0	0	0	1	1	0	0	0

For any touching detected, the system will count the cover area of the touch point and determine if it is a valid finger touch. If the touching area is over Max_Area, the system will report Large Object rather than a finger touch.

Control depth of image segmentation (R37h)

R/W	Parameter	IB7	IB6	IB5	IB4	IB3	IB2	IB1	IB0
W	1	--	--	--	--	--	Slicing_depth		
POR		0	0	0	0	0	1	0	0

Controlling the image segmentation depth can improve the SNR.

Select CG calculation method (R39h)

R/W	Parameter	IB7	IB6	IB5	IB4	IB3	IB2	IB1	IB0
W	1	--	--	--	--	--	--	CG	
POR		0	0	0	0	0	0	1	0

This command is used to improve the stability of different panel.

Select blending percentage in hybrid CG calculation (R3Ah)

R/W	Parameter	IB7	IB6	IB5	IB4	IB3	IB2	IB1	IB0
W	1	--	--	--	--	--	--	--	Hybrid_pent
POR		0	0	0	0	0	0	0	0

This command is used to select blending percentage in hybrid CG calculation.

Bypass init sequence (R3Ch)

R/W	Parameter	IB7	IB6	IB5	IB4	IB3	IB2	IB1	IB0
W	1	--	--	--	--	--	--	--	Bypass_seq
POR		0	0	0	0	0	0	0	0

This command is used to select the bypass init sequence.

Select filter type for delta data (R3Dh)

R/W	Parameter	IB7	IB6	IB5	IB4	IB3	IB2	IB1	IB0
W	1	--	--	--	--	--	--	--	Type_Filter
POR		0	0	0	0	0	0	0	0

This command is used to select the filter type for the delta data.

Switch off auto calibration (R3Eh)

R/W	Parameter	IB7	IB6	IB5	IB4	IB3	IB2	IB1	IB0
W	1	--	--	--	--	--	--	--	Auto_Cal
POR		0	0	0	0	0	0	0	0

This command is used to switch off the auto calibration. (Not recommended to switch off)

CG Tolerance Setting Register (R53h)

R/W	Parameter	IB7	IB6	IB5	IB4	IB3	IB2	IB1	IB0
W	1	--	CG_Tole						
POR		0	0	0	0	1	0	1	0

CG means Center of Gravity which is approximately the center point of the touch area. The setting of CG_Tole indicated how much deviation on a touching point is allowed between two scanning frame.

If the deviation of a touch point is over CG_Tole, it will be treated as a new finger touch and lost track with pervious touch finger number. Contrarily, the finger touch will treat as same finger detected previously.

The setting of CG_tole is in unit step.

The concept of touch deviation are showed below.

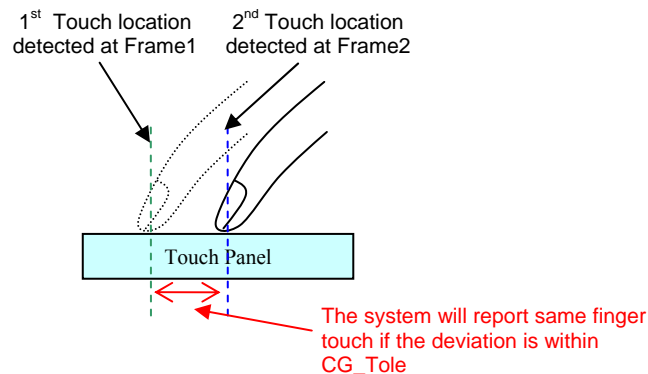

X Tracking Tolerance Register (R54h)

R/W	Parameter	IB7	IB6	IB5	IB4	IB3	IB2	IB1	IB0
W	1	--	--	--	--	--	--	--	--
W	2	X_Tole							
POR		0	0	0	0	0	0	0	0
		0	0	0	0	1	0	0	0

Similar to the CG Tolerance Setting, X_Tole determine the touch point deviation between two scanning frame in X-direction. The finger will lost track if the deviation is too large. This register is mainly for setting the movement tracking condition.

Y Tracking Tolerance Register (R55h)

R/W	Parameter	IB7	IB6	IB5	IB4	IB3	IB2	IB1	IB0
W	1	--	--	--	--	--	--	--	--
W	2	Y_Tole							
POR		0	0	0	0	0	0	0	0
		0	0	0	0	1	0	0	0

Y_Tole determine the touch point deviation between two scanning frame in Y-direction.

Enable Adaptive Moving Average filter to smooth fingers' output coordinates. (R56h)

R/W	Parameter	IB7	IB6	IB5	IB4	IB3	IB2	IB1	IB0
W	1	e-filter							
POR		0	0	0	0	0	0	1	0

This command is used for noise rejection.

Remap fingers' coordinates according to different orientation (R65h)

R/W	Parameter	IB7	IB6	IB5	IB4	IB3	IB2	IB1	IB0
W	1	--	--	--	--	--	Invert		
POR		0	0	0	0	0	0	0	0

This command is used to remap fingers' coordinates with different orientation.

Scaling factor for X coordinate. Floating point format is 0.#####0000. (R66h)

Refer to the Application Note.

Scaling factor for Y coordinate. Floating point format is 0.#####0000. (R67h)

Refer to the Application Note.

Offset of X coordinate. (R68h)

This register is to set the offset value for X coordinate.

Offset of Y coordinate. (R69h)

This register is to set the offset value for Y coordinate.

Touch Status (R79h)

R/W	Parameter	IB7	IB6	IB5	IB4	IB3	IB2	IB1	IB0
R	1	--	--	F9	F8	F7	F6	F5	F4
R	21	F3	F2	F1	F0	AS	LO	OF	VF
POR		0	0	0	0	0	0	0	0

This register showed the status of the touch detection. When a touch event is detected, the IRQ signal will set to low and at least one bit on this register will set to “1” to indicate the touch status. This register is “0” if the IRQ signal is high.

Register	Name	Function
F9	Finger9 Detected	This bit will set to “1” indicating the present of 10 th finger
F8	Finger8 Detected	This bit will set to “1” indicating the present of 9 th finger
F7	Finger7 Detected	This bit will set to “1” indicating the present of 8 th finger
F6	Finger6 Detected	This bit will set to “1” indicating the present of 7 th finger
F5	Finger5 Detected	This bit will set to “1” indicating the present of 6 th finger
F4	Finger4 Detected	This bit will set to “1” indicating the present of 5 th finger
F3	Finger3 Detected	This bit will set to “1” indicating the present of 4 th finger
F2	Finger2 Detected	This bit will set to “1” indicating the present of 3 rd finger
F1	Finger1 Detected	This bit will set to “1” indicating the present of 2 nd finger
F0	Finger0 Detected	This bit will set to “1” when 1 st finger touch detected
AS	Abnormal status	This bit will set to “1” when abnormal status detected.
LO	Large Object	If a touch detected with touch area over Max Finger Area (R16h), this bit will set to “1”
OF	FIFO Overflow	This bit will set to “1” if Touch Event Stack has over 8 events stored
VF	FIFO Data valid	This bit will set to “1” if Touch Event Stack is valid data

Event Mask (R7Ah)

R/W	Parameter	IB7	IB6	IB5	IB4	IB3	IB2	IB1	IB0
W	1	Reserved							
W	2	1	1	FL	FM	FE	1	1	1
POR		1	1	1	1	1	1	1	1
POR		1	1	0	0	0	1	1	1

IRQ Mask (R7Bh)

R/W	Parameter	IB7	IB6	IB5	IB4	IB3	IB2	IB1	IB0	
W	1	---			F9	F8	F7	F6	F5	F4
W	2	F3	F2	F1	F0	AS	LO	OF	VF	
POR		0	0	0	0	0	0	0	0	
POR		0	0	0	0	0	0	0	0	

Finger01-10 (X,Y) coordinates, speed index and press weight index. (R7Ch – R85h)

R/W	Parameter	IB7	IB6	IB5	IB4	IB3	IB2	IB1	IB0
R	1	x-coor[7:0]							
R	2	y-coor[7:0]							
R	3	x-coor[11:8]				y-coor[11:8]			
R	4	weight index[3:0]				speed index [3:0]			
POR	1	1	1	1	1	1	1	1	1
	2	1	1	1	1	1	1	1	1
	3	1	1	1	1	1	1	1	1
	4	0	0	0	0	0	0	0	0

SSD2533 can detect maximum of 10 fingers touch on the panel. Ten registers are used to report the x-y coordinate of the 10 fingers if present and only the most concurrent coordinates are reported.

The first touch point will put to R7Ch and the second touch point will put to R7Dh and so on. Once the finger number had been assigned, the system will keep tracking the same finger and update the latest x-y coordinate to same register until the finger leaving the touch screen.

Event Stack (R86h)

R/W	Parameter	IB7	IB6	IB5	IB4	IB3	IB2	IB1	IB0	
R	1	Finger_Flag				Event_No				
R	2	x-coor[7:0]								
R	3	y-coor[7:0]								
R	4	x-coor[11:8]				y-coor[11:8]				
R	5	weight index[3:0]				speed index [3:0]				
POR	1	0	0	0	0	0	0	0	0	
	2	1	1	1	1	1	1	1	1	
	3	1	1	1	1	1	1	1	1	
	4	1	1	1	1	1	1	1	1	
	5	0	0	0	0	0	0	0	0	

SSD2533 has a hardware interrupt line (IRQ) connected to the host processor. This interrupt line is active low and different kinds of events can activate this IRQ line. In any cases, at least one bit of the Touch Event Status Register (R79h) will be “1”. If all bits of the Touch Event Status Register are “0”, the IRQ line will return to its inactive state (high). The IRQ can be activating by 1, 2 and 3 fingers only. The fourth finger will not trigger any interrupt event.

The following diagram shows the relationship between Touch Events, Event Stack, IRQ line and IIC interface. The IRQ line will change back to inactive high when the last bit of the last event is transferred from the event stack to the host processor.

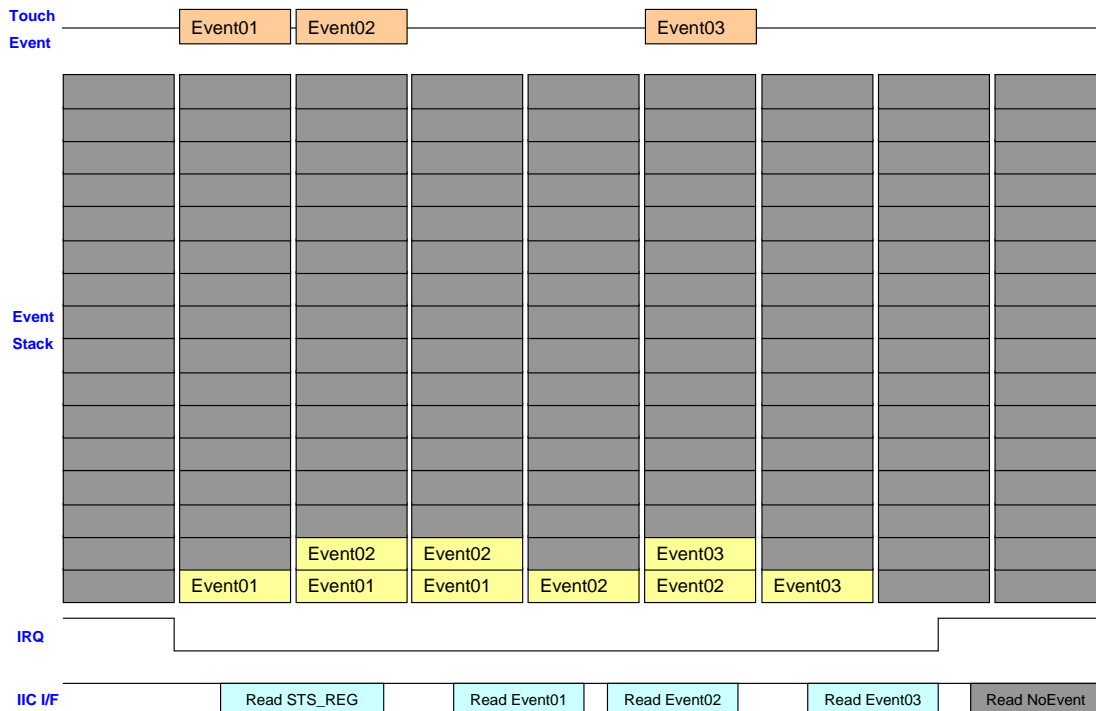

The Event Stack has a capacity to store **sixteen** events. If events are not handled by the host processor, they are stuck in the Event Stack. Once the FIFO is full, no more entry for new events is possible. The events must be read out or cleared by command Event Stack Clear (R87h) before new entries are available.

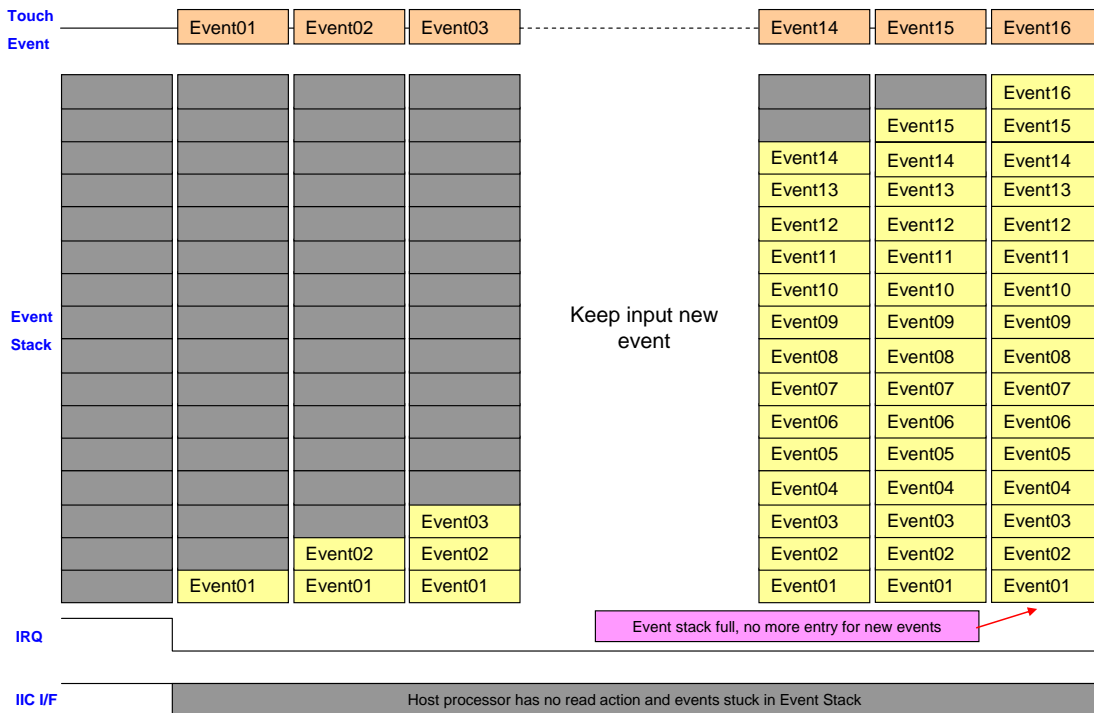

Event Stack Clear (R87h)

This command is used for clear the event stack. If overflow occurred, the event stack cannot be cleared. Please read 0x79,0x86 and send 0x87.

Reset Init Reference Procedure (RA2h)

A dummy byte should be sent after this command to activate the init reference procedure again

Select Driving voltage level (RD5h)

R/W	Parameter	IB7	IB6	IB5	IB4	IB3	IB2	IB1	IB0
W	1	Reserved				DVL			
	POR	0	0	0	0	0	0	1	1

This register controls the output voltage of the driving line (5.5V to 9V).

Select ADC Vref range (RD7h)

R/W	Parameter	IB7	IB6	IB5	IB4	IB3	IB2	IB1	IB0
W	1	--				Vref			
	POR	0	0	0	0	0	1	0	0

Select Sense line biasing resistance (RD8h)

R/W	Parameter	IB7	IB6	IB5	IB4	IB3	IB2	IB1	IB0
W	1	--				BIAS_RES			
	POR	0	0	0	0	0	1	0	0

Set integrator cap value (RDBh)

R/W	Parameter	IB7	IB6	IB5	IB4	IB3	IB2	IB1	IB0
W	1	--				CI2 CI1 CI0			
	POR	0	0	0	1	0	0	0	0

10 REGISTERS

VDDIO = VCI = 2.775V

- 1.) Hardware Reset
- 2.) Set the number of driver line.
- 3.) Set the number of sense line.
- 4.) Set the driver line scanning order.
- 5.) Turn on the booster circuit and set the VOUT to ~7.5V.

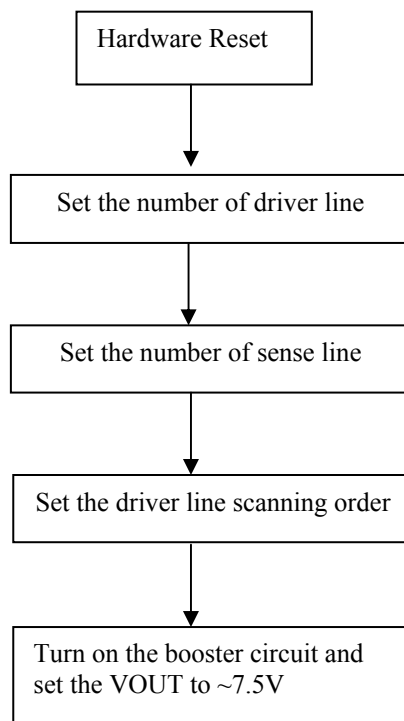

11 MAXIMUM RATINGS

Table 11-1: Maximum Ratings (Voltage Referenced to V_{SS})

Symbol	Parameter	Value	Unit
V_{CORE}	Supply Voltage for Logic	-0.3 to +2.0	V
V_{DDIO}	Supply Voltage for I/O	-0.3 to +4.0	V
V_{CI}	Input Voltage	$V_{SS} - 0.3$ to +5.0	V
I	Current Drain Per Pin Excluding V_{CORE} and V_{SS}	25	mA
T_A	Operating Temperature	-40 to +85	°C
T_{STG}	Storage Temperature	-65 to +150	°C

Maximum ratings are those values beyond which damages to the device may occur. Functional operation should be restricted to the limits in the Electrical Characteristics tables or Pin Description section

This device contains circuitry to protect the inputs against damage due to high static voltages or electric fields; however, it is advised that normal precautions be taken to avoid application of any voltage higher than maximum rated voltages to this high impedance circuit. For proper operation it is recommended that V_{CI} and V_{OUT} be constrained to the range $V_{SS} < V_{DD} \leq V_{CI} < V_{OUT}$. Reliability of operation is enhanced if unused input is connected to an appropriate logic voltage level (e.g., either V_{SS} or V_{DD}). Unused outputs must be left open. This device may be light sensitive. Caution should be taken to avoid exposure of this device to any light source during normal operation. This device is not radiation protected.

12 DC CHARACTERISTICS

DC Characteristics (Unless otherwise specified, Voltage Referenced to V_{SS} , $T_A = -40$ to 85°C)

Symbol	Parameter	Conditions	Min	Typ	Max	Unit
V_{DDIO}	Power supply pin of I/O pins	Recommend Operating Voltage Possible Operating Voltage	1.65	-	3.3	V
V_{CI}	Booster Reference Supply Voltage Range (3)	Recommend Operating Voltage Possible Operating Voltage	2.5 or V_{DDIO}	-	3.3	V
I_{sleep1}	Sleep mode current (V_{CI} pin)	$V_{DDIO}=1.8V, V_{CI}=3.3V$	-	10	50	μA
I_{sleep2}	Sleep mode current (V_{DDIO} pin)		-	1	10	μA
I_{dp}	Operating mode current	$V_{DDIO}=1.8V, V_{CI}=3.3V$ $I_{DP} = I_{VDDIO} + I_{VCI}$	-	13	18	mA
VOUT	VOUT booster efficiency	See Note1	70	85	-	%
VOH1	Logic High Output Voltage	$I_{out} = -100\mu\text{A}$	$0.9 * V_{DDIO}$	-	V_{DDIO}	V
VOL1	Logic Low Output Voltage	$I_{out} = 100\mu\text{A}$	0	-	$0.1 * V_{DDIO}$	V
VIH1	Logic High Input voltage		$0.8 * V_{DDIO}$	-	V_{DDIO}	V
VIL1	Logic Low Input voltage		0	-	$0.2 * V_{DDIO}$	V
I_{OH}	Logic High Output Current Source	$V_{OH} = V_{DDIO} - 0.4V$	50	-	-	μA
I_{OL}	Logic Low Output Current Drain	$V_{OL} = 0.4V$	-	-	-50	μA
I_{OZ}	Logic Output Tri-state Current Drain Source		-1	-	1	μA
I_{IL}/I_{IH}	Logic Input Current		-1	-	1	μA

13 AC CHARACTERISTICS

Conditions:

$$V_{DD} - V_{SS} = 2.4 \text{ to } 3.5\text{V}$$

$$V_{DDIO} = V_{DD}$$

$$T_A = 25^\circ\text{C}$$

Table 13-1 :I²C Interface Timing Characteristics

Symbol	Parameter	Min	Typ	Max	Unit
t _{cycle}	Clock Cycle Time	2.5	-	-	us
t _{HSTART}	Start condition Hold Time	0.6	-	-	us
t _{HD}	Data Hold Time (for “SDA” pin)	0	-	-	ns
t _{SD}	Data Setup Time	100	-	-	ns
t _{SSTART}	Start condition Setup Time (Only relevant for a repeated Start condition)	0.6	-	-	us
t _{SSTOP}	Stop condition Setup Time	0.6	-	-	us
t _R	Rise Time for data and clock pin	-	-	300	ns
t _F	Fall Time for data and clock pin	-	-	300	ns
t _{IDLE}	Idle Time before a new transmission can start	1.3	-	-	us

Figure 13-1 : I²C interface Timing characteristics

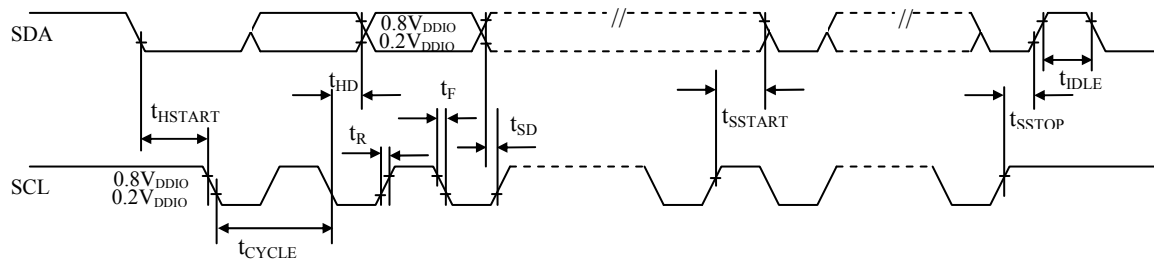

Table 13-2 : Serial Timing Characteristics (TA = -40 to 85° C, VDDIO = 2.7V, VSS = 0V)

Symbol	Parameter	Min	Typ	Max	Unit
t _{cycle}	Clock Cycle Time	58.8	-	-	ns
t _{AS}	Address Setup Time	10	-	-	ns
t _{AH}	Address Hold Time	5	-	-	ns
t _{CSS}	Chip Select Setup Time	30	-	-	ns
t _{CSH}	Chip Select Hold Time	29.4	-	-	ns
t _{DSW}	Write Data Setup Time	30	-	-	ns
t _{DHW}	Write Data Hold Time	30	-	-	ns
t _{CLKL}	Clock Low Time	29.4	-	-	ns
t _{CLKH}	Clock High Time	29.4	-	-	ns
t _R	Rise Time	-	-	15	ns
t _F	Fall Time	-	-	15	ns

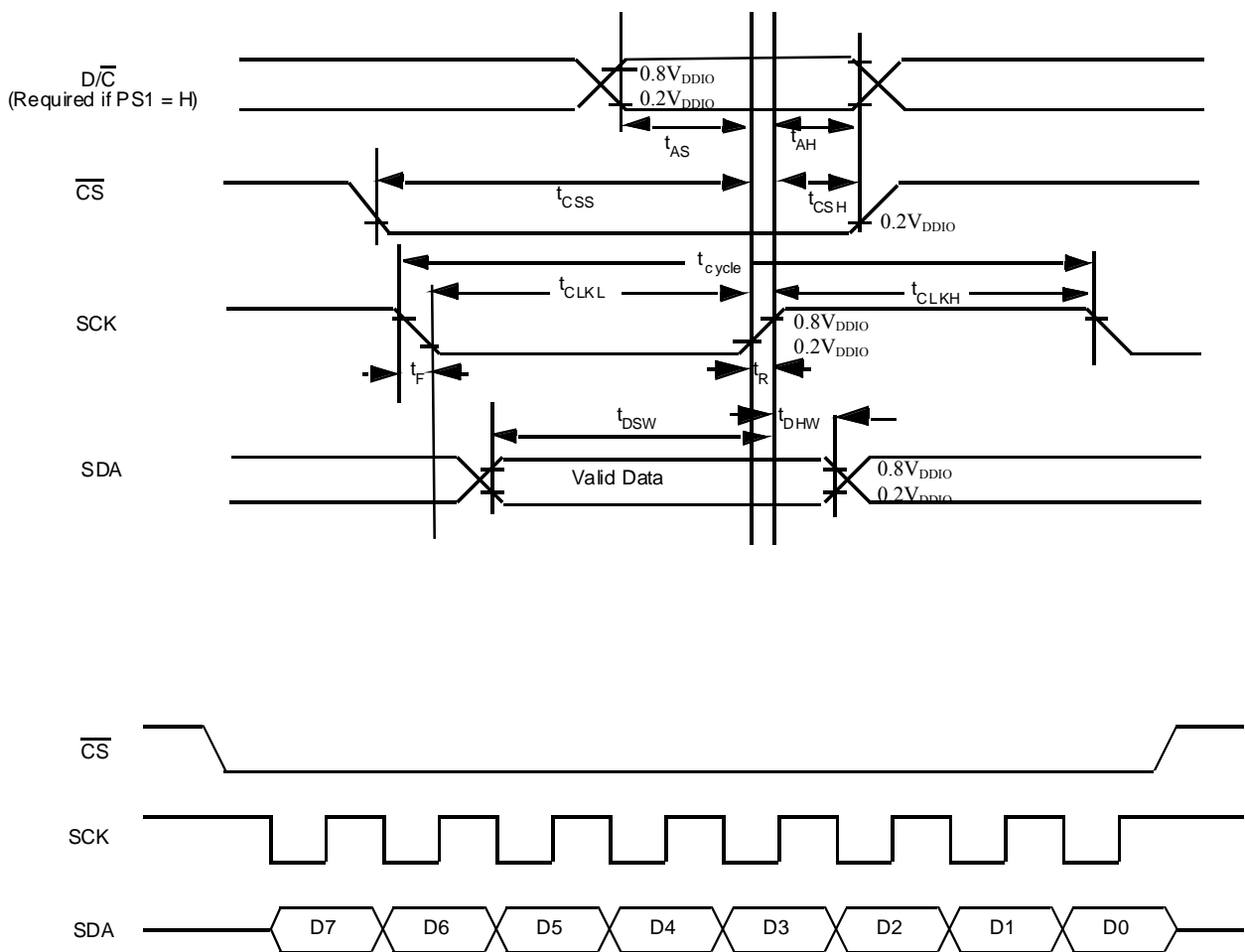
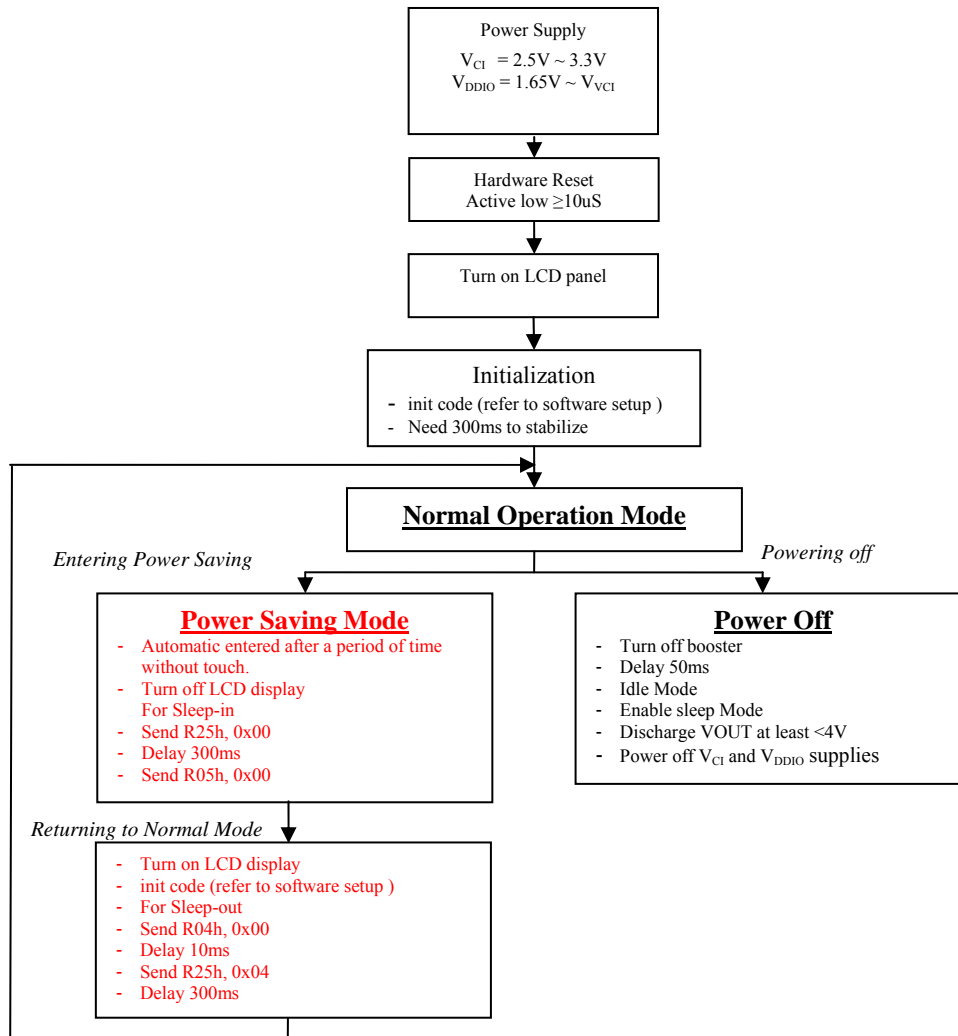

Figure 13-2 : Serial Timing Characteristics

14 Power up/down Sequence

14.1 Power up / down flow chart

The figures below illustrate a flow chart and timing diagram for power up/down sequence of the driver.



Note: To prevent potential damage to the device, all capacitors must be discharged to below 0.5V before the driver is removed from, or before the driver is attached to those components.

14.2 Power up

Symbol	Parameter	Min	Typ	Max	Unit
t_{PR}	Power rise time	-	-	30	us
t_{PD}	Power delay time	-	-	30	us
t_{STABLE}	Chip stable time	-	-	10	us
t_{RES}	Reset pulse	4	-	-	us
t_{READY}	Chip need time after hardware reset	1	-	-	us

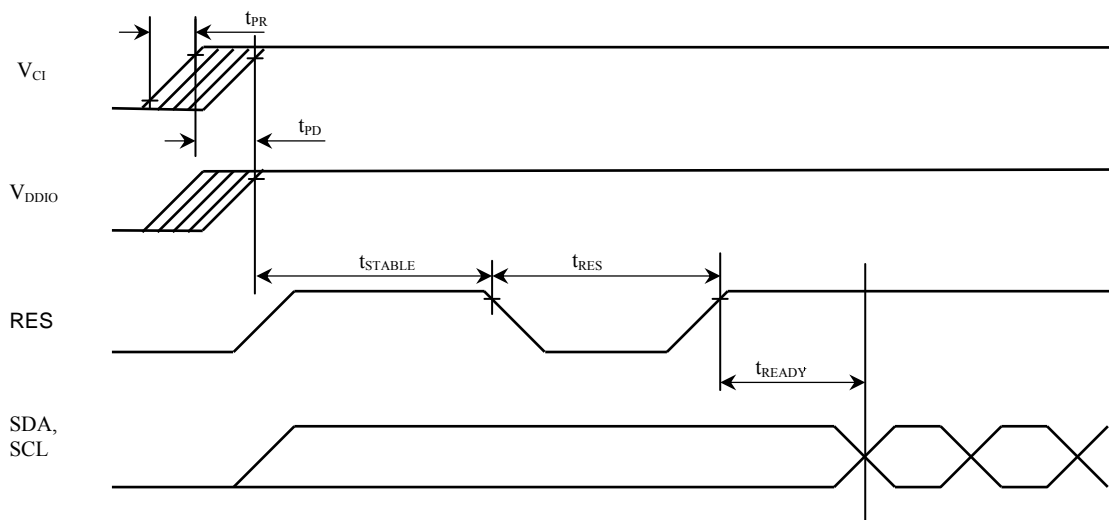

14.3 Power down

Symbol	Parameter	Min	Typ	Max	Unit
$t_{DISCHARGE}$	V_{OUT} discharge wait time	50	-	-	ms
t_{PDOWN}	Power Hold time	50	-	-	ms

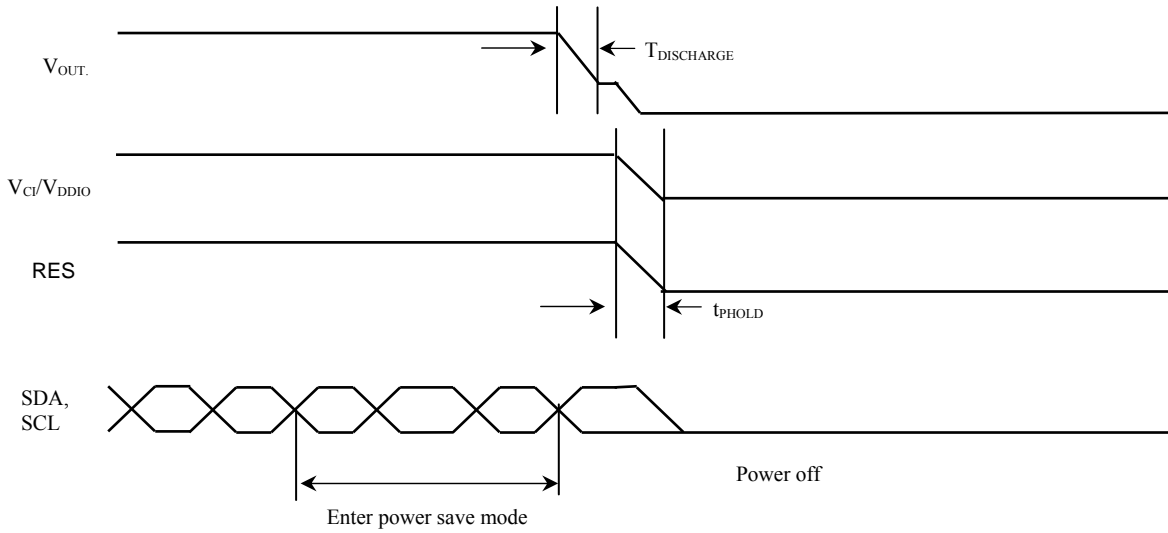

- With regards to the Power Off, V_{out} should be discharged at least below than 5V before turn off the V_{CI}/V_{DDIO} power supplies

15 APPLICATION EXAMPLES

15.1 Application Diagram

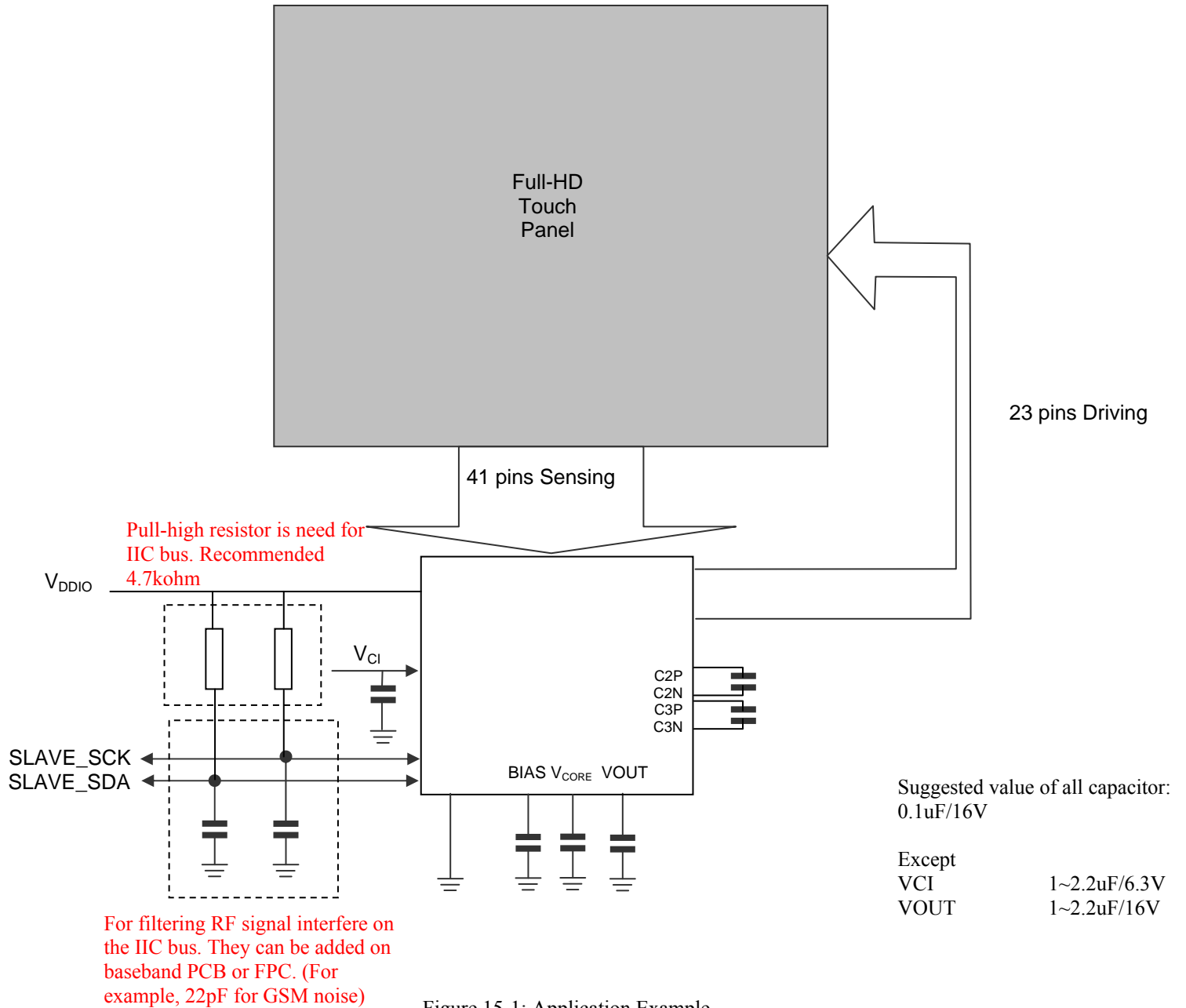

Figure 15-1: Application Example

15.2 Panel design reference

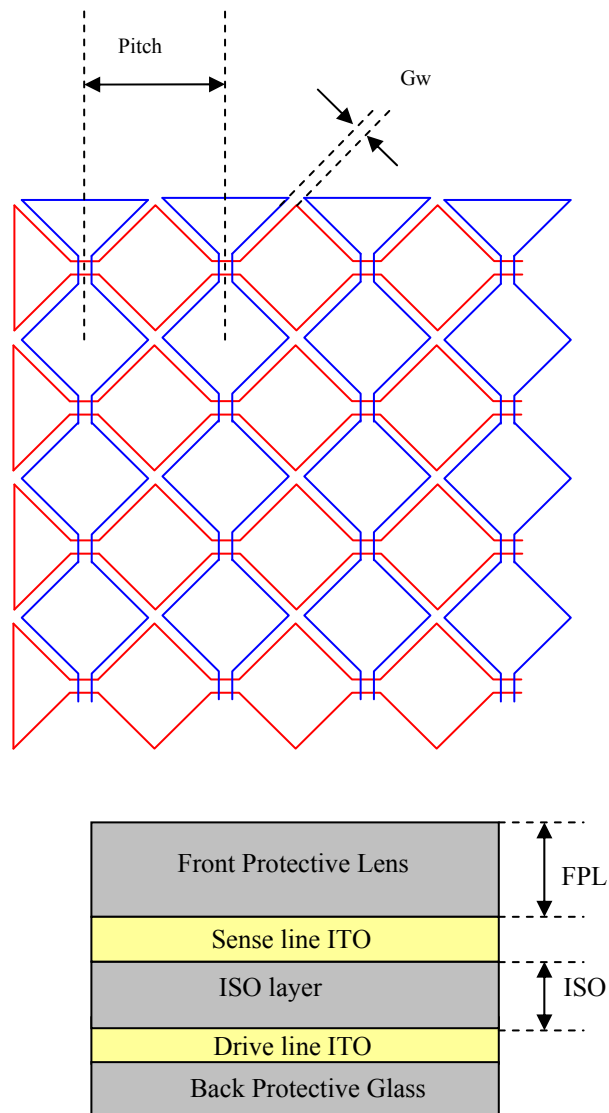

Table 15-1 : 5 Inch Touch Panel Characteristics

Symbol	Parameter	Min	Typ	Max	Unit
Rdrive	Drive line resistance	-	4	6	k Ω
Rsense	Sense line resistance	-	4	6	k Ω
Pitch	Touch pattern pitch	3	-	6	mm
Gw	Pattern Gap width	0.1	0.3	1	mm
ISO	Isolation Glass thickness	-	-	0.6	mm
FPL	Front Protective Lens	0.5	0.7	1.5	mm

Table 15-2 : 7 to 10 Inch Touch Panel Characteristics

Symbol	Parameter	Min	Typ	Max	Unit
Rdrive	Drive line resistance	-	15	20	k Ω
Rsense	Sense line resistance	-	15	20	k Ω
Pitch	Touch pattern pitch	3	-	6	mm
Gw	Pattern Gap width	0.1	0.3	1	mm
ISO	Isolation Glass thickness	-	-	0.6	mm
FPL	Front Protective Lens	0.5	0.7	1.5	mm

- *Drive line resistance and Sense line resistance included the Diamond pattern, routing trace, FPC and package resistance.*
- *Metal coating is recommended for the ITO trace.*
- *GND line is recommended to insert between the drive and sense line.*

15.3 FPC design reference

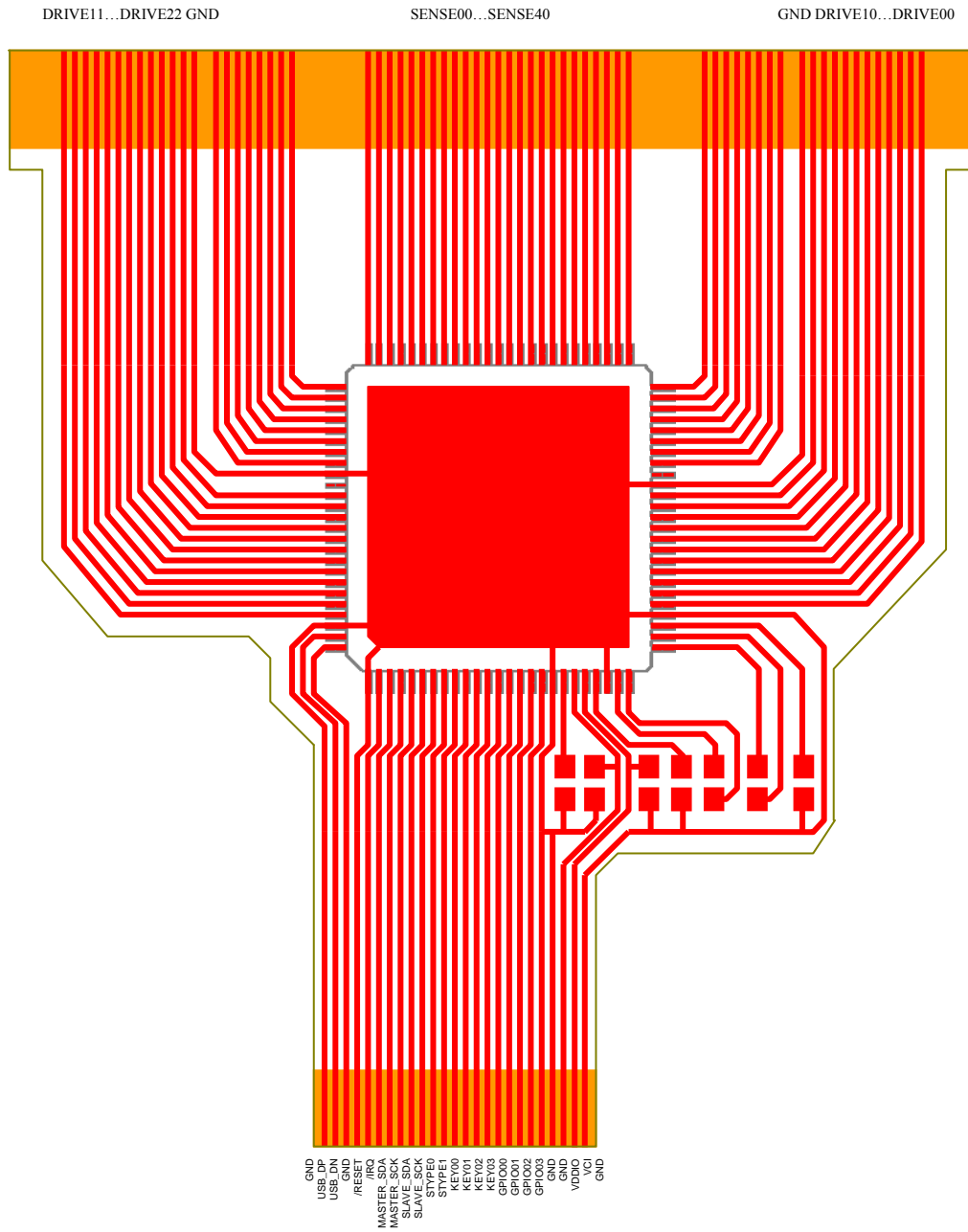

- *GND line is recommended to insert between the drive and sense line.*
- *The DRIVE line should not cross over the SENSE line.*

15.4 FPC Layout Example for QFP100 with EEPROM

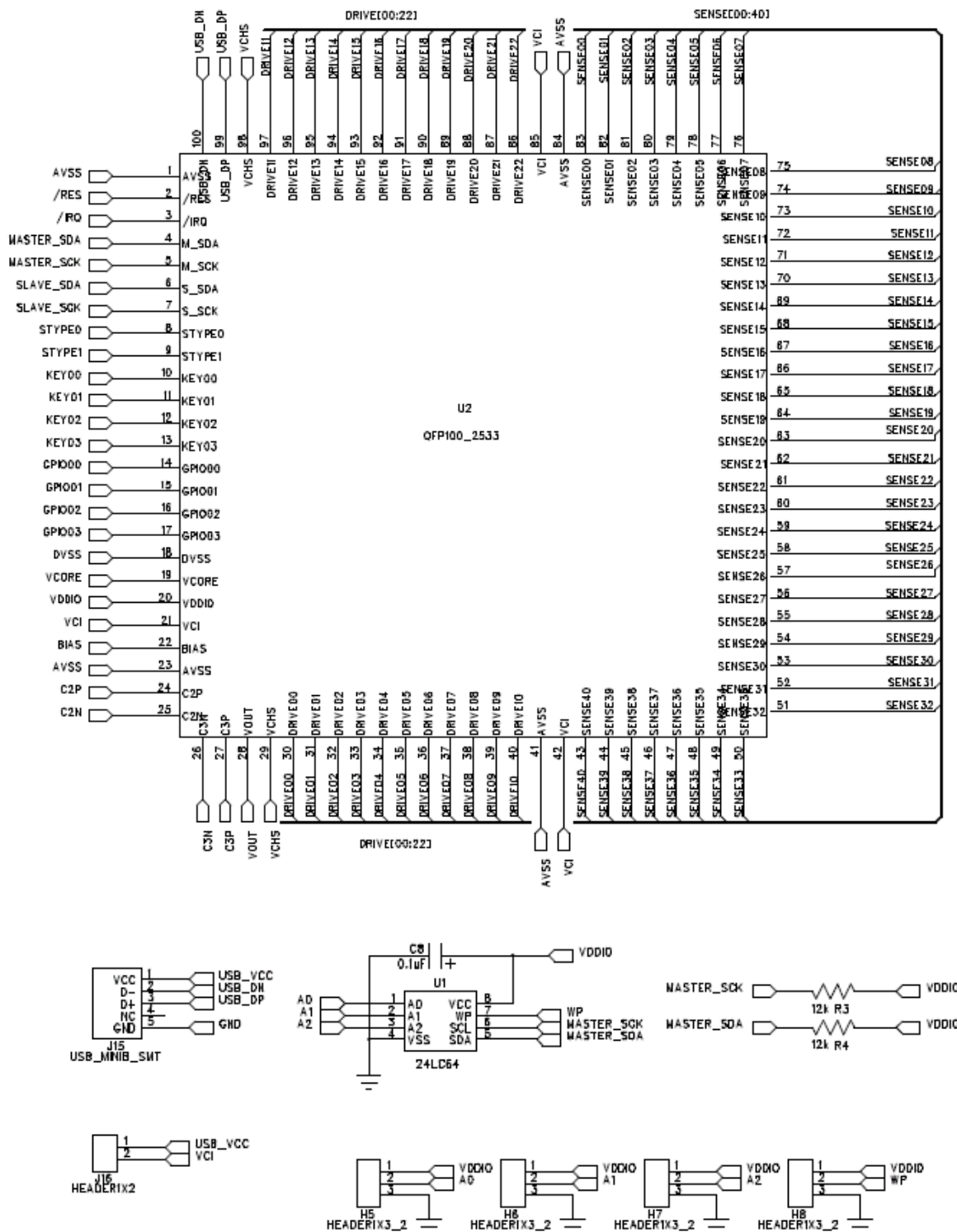

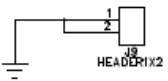
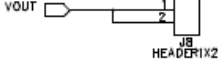
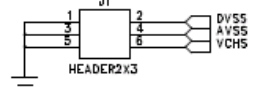
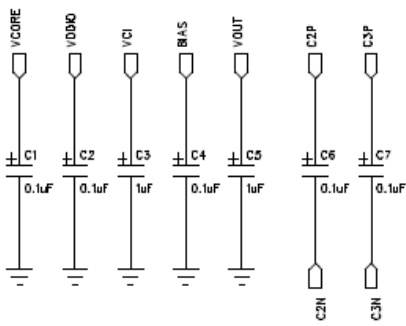
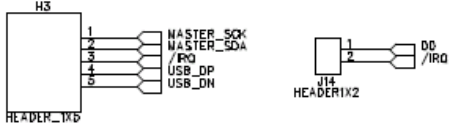
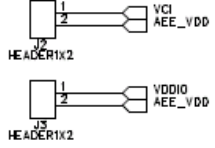
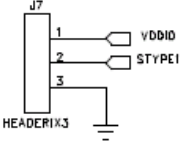
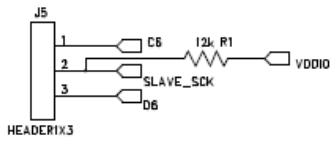
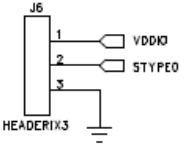
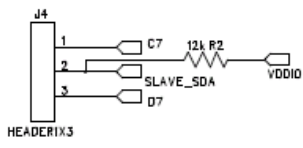
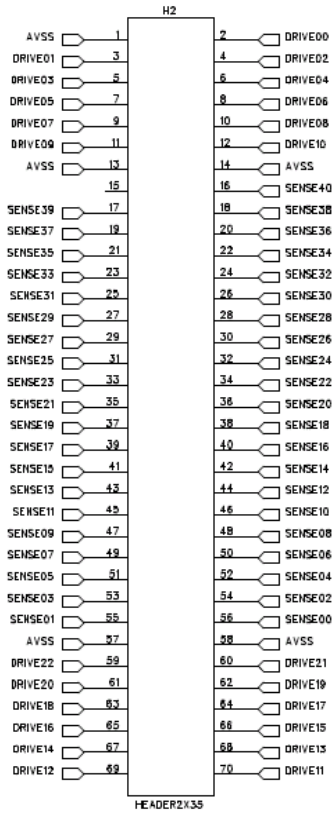

15.5 Initialization Program

```

AEE_IIC &H04,&H00      'Exit Sleep mode
delay 300

AEE_IIC &HAC,&H01      'SelfCap IIR filter
AEE_IIC &HAD,&H03      'Scan Rate
AEE_IIC &HAE,&H0F      'SelfCap Enable
AEE_IIC &HAF,&H30      'SelfCap Threshold
'AEE_IIC &HB0,&H00     'SelfCap R
'AEE_IIC &HBB,&H00     'SelfCap Window

AEE_IIC &HBC,&H01      'Selfcap Enable

AEE_IIC &H06,&H16      'Drive Line#
AEE_IIC &H07,&H28      'Sense Line#

AEE_IIC2 &H08,&H00,&H80
AEE_IIC2 &H09,&H00,&H81
AEE_IIC2 &H0A,&H00,&H82
AEE_IIC2 &H0B,&H00,&H83
AEE_IIC2 &H0C,&H00,&H84
AEE_IIC2 &H0D,&H00,&H85
AEE_IIC2 &H0E,&H00,&H86
AEE_IIC2 &H0F,&H00,&H87
AEE_IIC2 &H10,&H00,&H88
AEE_IIC2 &H11,&H00,&H89
AEE_IIC2 &H12,&H00,&H8A
AEE_IIC2 &H13,&H01,&H8B
AEE_IIC2 &H14,&H01,&H8C
AEE_IIC2 &H15,&H01,&H8D
AEE_IIC2 &H16,&H01,&H8E
AEE_IIC2 &H17,&H01,&H8F
AEE_IIC2 &H18,&H01,&H90
AEE_IIC2 &H19,&H01,&H91
AEE_IIC2 &H1A,&H01,&H92
AEE_IIC2 &H1B,&H01,&H93
AEE_IIC2 &H1C,&H01,&H94
AEE_IIC2 &H1D,&H01,&H95
AEE_IIC2 &H1E,&H01,&H96

AEE_IIC &HD5,&H03      'Vout Voltage
AEE_IIC &HD8,&H07      'Sense Bias R

AEE_IIC &H2A,&H07      'Sub-Frame
AEE_IIC &H2C,&H01      'Median Filter enable
AEE_IIC &H2E,&H0B      'Drive Pulse
AEE_IIC &H2F,&H01      'Integration Gain

AEE_IIC &H30,&H03      'Integration Start Window
AEE_IIC &H31,&H07      'Integration Stop Window
AEE_IIC &HD7,&H04      'ADC Range
AEE_IIC &HDB,&H04      'Integration Cap

AEE_IIC2 &H33,&H00,&H01      'Min Finger Area
AEE_IIC2 &H34,&H00,&H30      'Min Finger level
AEE_IIC2 &H35,&H00,&H00      'Min Finger Weight
AEE_IIC2 &H36,&H00,&H1F      'Max Finger Area

AEE_IIC &H37,&H00      'Segmentation Depth
AEE_IIC &H3D,&H01      '2D filter

```

AEE_IIC &H53,&H16 'Event move tolerance
 AEE_IIC2 &H54,&H00,&H80 'X Tracking
 AEE_IIC2 &H55,&H00,&H80 'Y Tracking

 AEE_IIC &H56,&H02 'Moving Average
 AEE_IIC &H58,&H00 'Finger Weight Scaling
 AEE_IIC &H59,&H01 'Enable Random Walk
 AEE_IIC &H5B,&H20 'Set Random Walk window

 AEE_IIC &H65,&H03 'XY Mapping
 'AEE_IIC2 &H66,&H63,&HE0 'X Scaling
 'AEE_IIC2 &H67,&H68,&H50 'Y Scaling

 AEE_IIC2 &H7A,&HFF,&HFF 'Event Mask
 AEE_IIC2 &H7B,&HFF,&HFF 'IRQ Mask

 AEE_IIC &H89,&H01 'Enable Frame IRQ mode
 AEE_IIC &H8A,&H0A 'Max Finger

 AEE_IIC &H8B,&H10 '1.5X mode
 AEE_IIC &H8C,&HB0 'Edge compensation

 AEE_IIC &H25,&H02 'Scan Rate
 delay 300

16 PACKAGE INFORMATION

16.1 TQFP 100 pins (12x12mm)

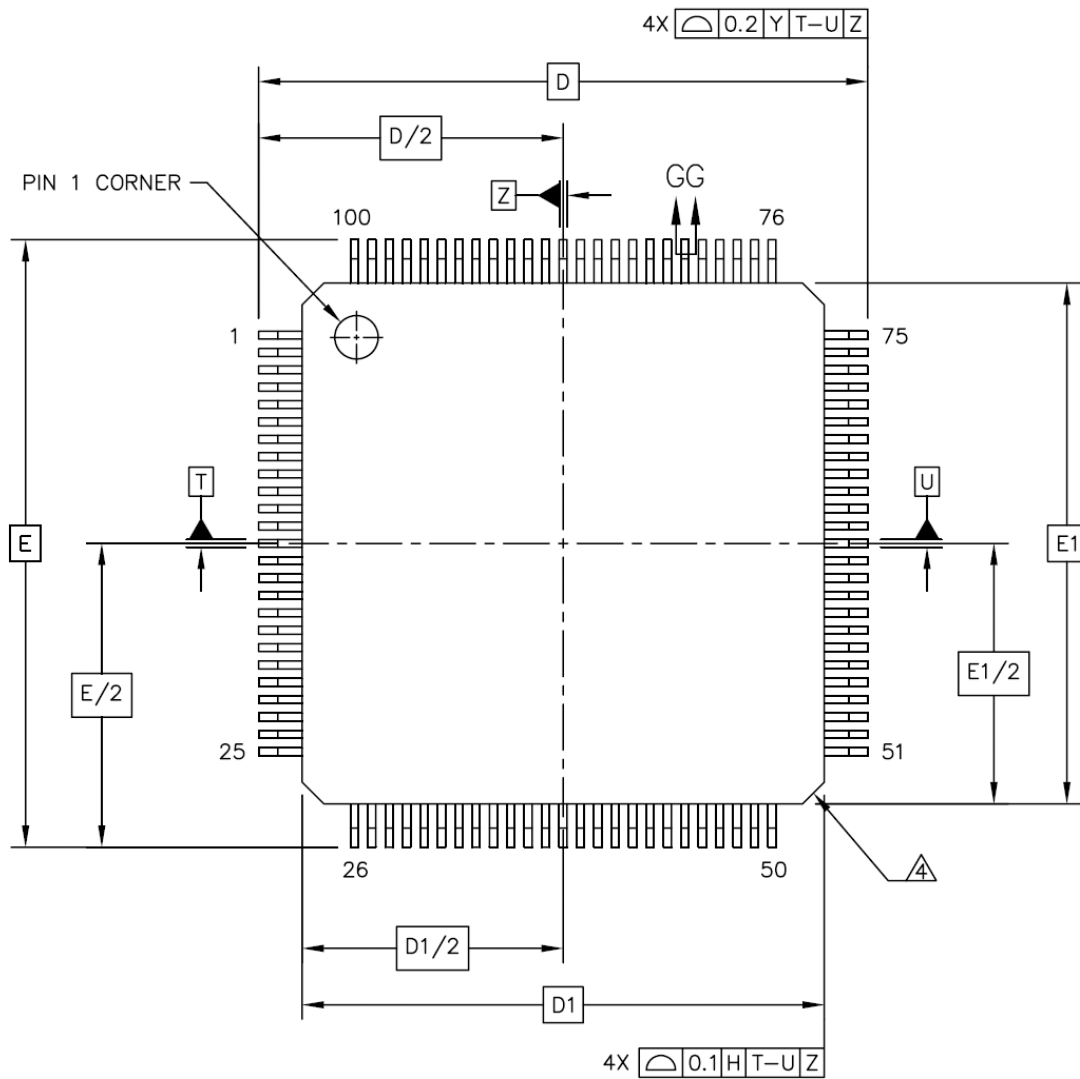

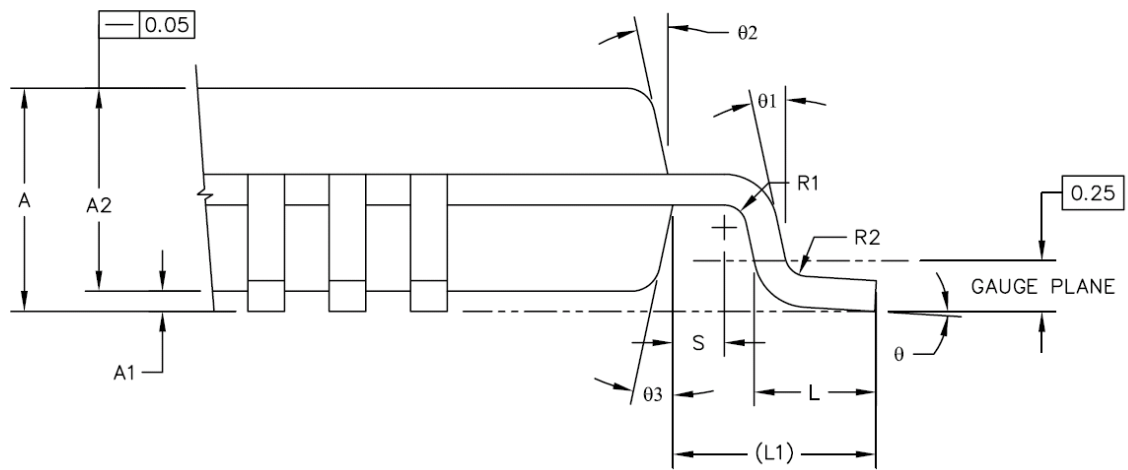
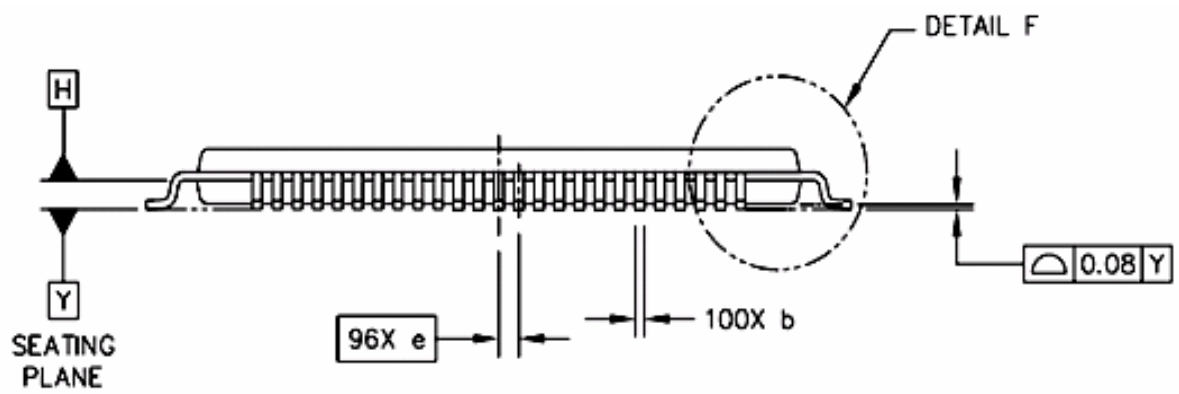

DETAIL F
 SCALE: 30/1

DIM	MIN	MAX	DIM	MIN	MAX
A	---	1.2	L1	1 REF	
A1	0.05	0.15	R1	0.08	---
A2	0.95	1	R2	0.08	0.2
b	0.13	0.18	S	0.2	---
b1	0.13	0.16	Ø	0°	3.5°
c	0.09	0.2	Ø1	0°	---
c1	0.09	0.16	Ø2	11°	12°
D	14 BSC		Ø3	11°	12°
D1	12 BSC				
e	0.4 BSC				
E	14 BSC				
E1	12 BSC				
L	0.45	0.6			0.75

16.3 QFN 88 pins (10 x 10 mm)

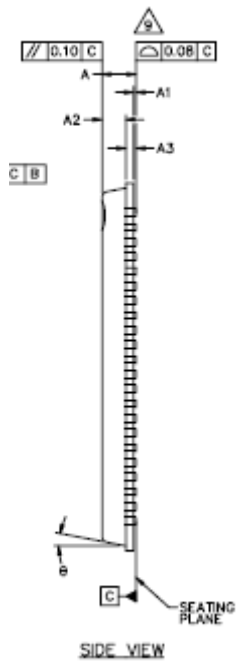
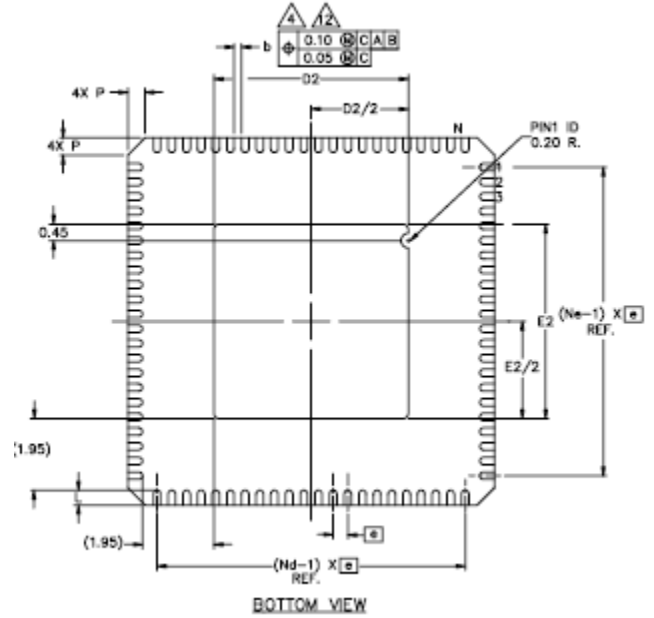
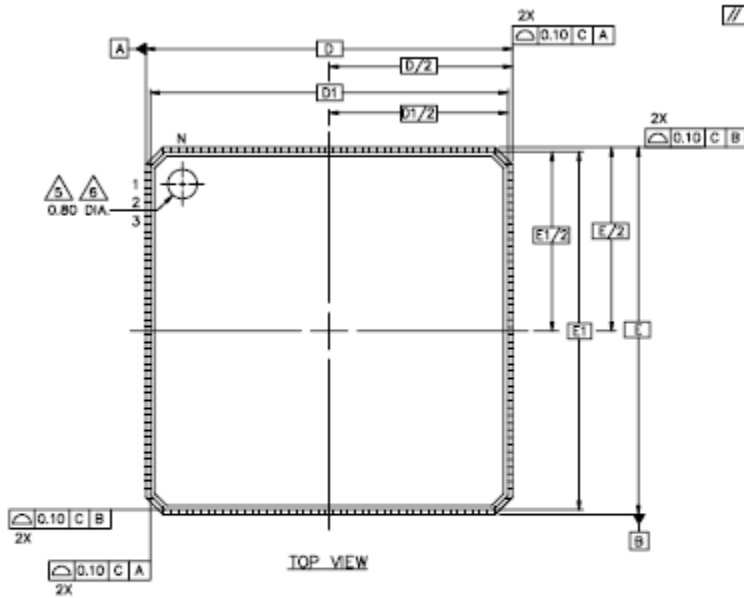

DIMENSION	COMMON DIMENSIONS			Notes
	MIN	NOM.	MAX	
A	0.80	0.85	0.90	
A1	0.00	0.01	0.05	10
A2	0.60	0.65	0.70	
A3	0.20 REF.			
D	10.00 BSC			
D1	9.75 BSC			
E	10.00 BSC			
E1	9.75 BSC			
D2	5.20	5.30	5.40	
E2	5.20	5.30	5.40	
Q	0.40 BSC			
N	88			3
Nd	22			3
Ne	22			3
L	0.30	0.40	0.50	
b	0.15	0.20	0.25	4
θ	0 - 12°			
P	0.24	0.42	0.60	

16.4 Package orientation

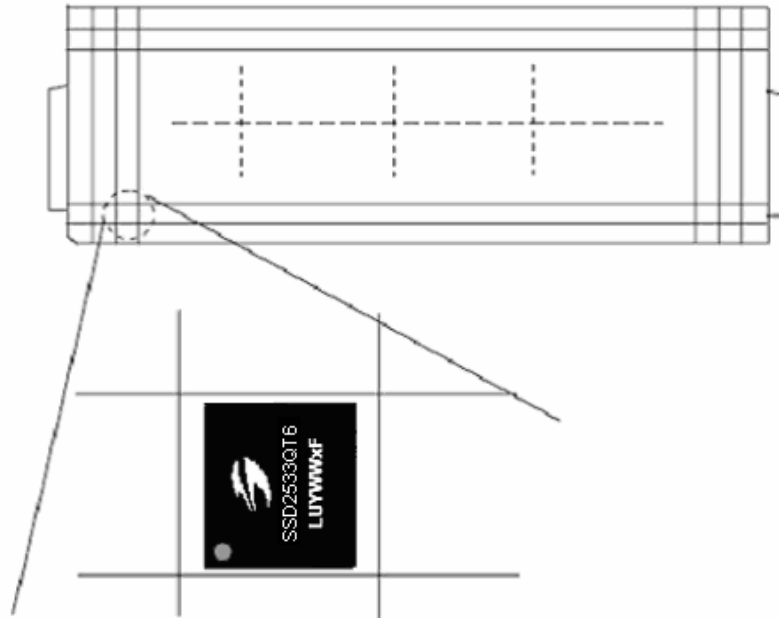

Figure 16-1 : SSD2533QT6 package orientation

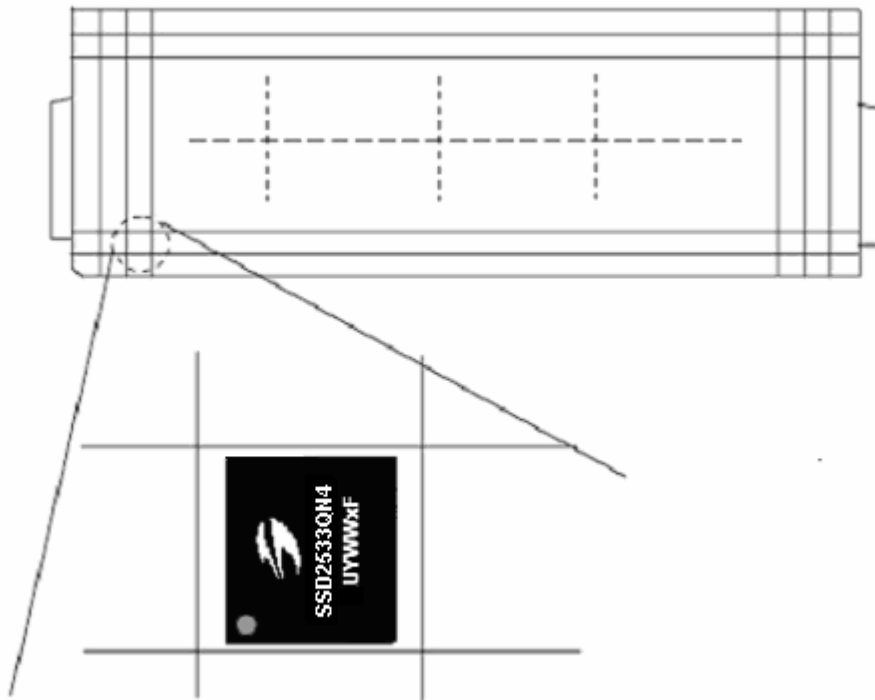

Figure 16-2 : SSD2533QN4 package orientation

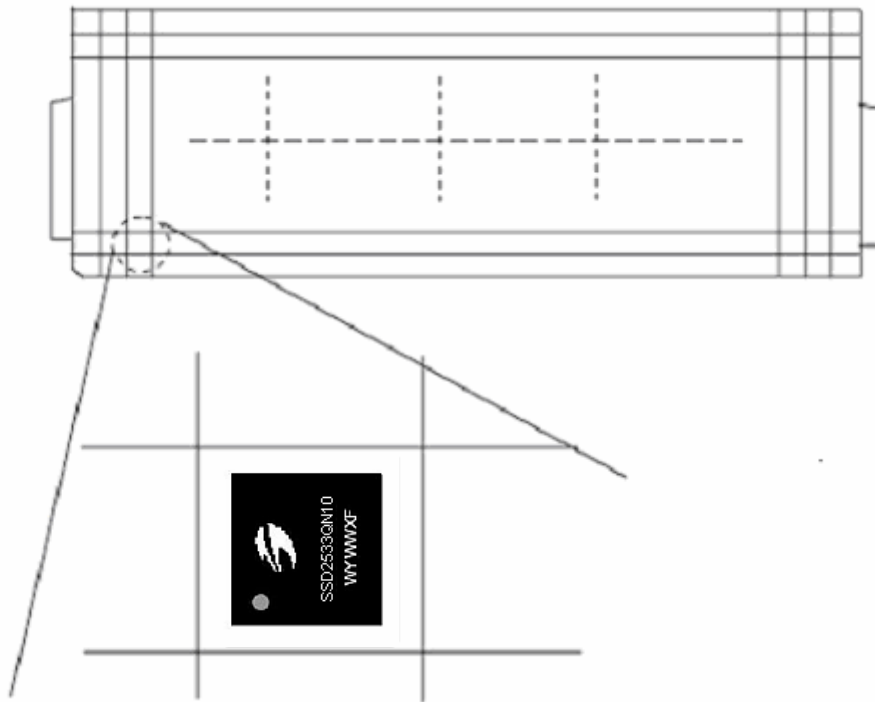

Figure 16-3 : SSD2533QN10 package orientation

Solomon Systech reserves the right to make changes without notice to any products herein. Solomon Systech makes no warranty, representation or guarantee regarding the suitability of its products for any particular purpose, nor does Solomon Systech assume any liability arising out of the application or use of any product or circuit, and specifically disclaims any, and all, liability, including without limitation consequential or incidental damages. “Typical” parameters can and do vary in different applications. All operating parameters, including “Typical” must be validated for each customer application by the customer’s technical experts. Solomon Systech does not convey any license under its patent rights nor the rights of others. Solomon Systech products are not designed, intended, or authorized for use as components in systems intended for surgical implant into the body, or other applications intended to support or sustain life, or for any other application in which the failure of the Solomon Systech product could create a situation where personal injury or death may occur. Should Buyer purchase or use Solomon Systech products for any such unintended or unauthorized application, Buyer shall indemnify and hold Solomon Systech and its offices, employees, subsidiaries, affiliates, and distributors harmless against all claims, costs, damages, and expenses, and reasonable attorney fees arising out of, directly or indirectly, any claim of personal injury or death associated with such unintended or unauthorized use, even if such claim alleges that Solomon Systech was negligent regarding the design or manufacture of the part.



The product(s) listed in this datasheet comply with Directive 2002/95/EC of the European Parliament and of the council of 27 January 2004 on the restriction of the use of certain hazardous substances in electrical and electronic equipment and People’s Republic of China Electronic Industry Standard SJ/T 11363-2006 “Requirements for concentration limits for certain hazardous substances in electronic information products (电子信息产品中有毒有害物质的限量要求)”. Hazardous Substances test report is available upon request.

With collaboration of <https://www.displayfuture.com>