

SSD1332

Advance Information

**96RGB x 64 Dot Matrix
OLED/PLED Segment/Common Driver with Controller**

This document contains information on a new product. Specifications and information herein are subject to change without notice.

TABLE OF CONTENTS

1	GERENAL INFORMATIOM.....	6
2	FEATURES.....	6
3	ORDERING INFORMATION.....	6
4	BLOCK DIAGRAM.....	7
5	SSD1332Z GOLD BUMP DIE PAD ASSIGNMENT.....	8
6	PIN DESCRIPTION.....	13
	BS0, BS1, BS2.....	13
	CS#.....	13
	RES#.....	13
	D/C.....	13
	R/W(WR#).....	13
	E (RD#).....	13
	D ₇ -D ₀	13
	V _{DD}	14
	V _{SS}	14
	V _{CC}	14
	V _{REF}	14
	V _{PA} , V _{PB} , V _{PC}	14
	I _{REF}	14
	V _{COMH}	14
	COM0-COM63.....	15
	SA0-SA95, SB0-SB95, SC0-SC95.....	15
7	FUNCTIONAL BLOCK DESCRIPTIONS.....	16
	OSCILLATOR CIRCUIT AND DISPLAY TIME GENERATOR.....	16
	RESET CIRCUIT.....	16
	COMMAND DECODER AND COMMAND INTERFACE.....	16
	CURRENT AND VOLTAGE SUPPLY.....	17
	SEGMENT DRIVERS/Common DRIVERS.....	18
	MPU PARALLEL 6800-SERIES INTERFACE.....	21
	MPU PARALLEL 8080-SERIES INTERFACE.....	21
	MPU SERIAL INTERFACE.....	21
	GRAPHIC DISPLAY DATA RAM (GDDRAM).....	22
	GRAY SCALE AND GRAY SCALE TABLE.....	23
	DC-DC VOLTAGE CONVERTER.....	25
8	COMMAND TABLE.....	26
	DATA READ / WRITE.....	30
9	COMMAND DESCRIPTIONS.....	31
10	GRAPHIC ACCELERATION COMMAND SET DESCRIPTION.....	38
11	MAXIMUM RATINGS.....	41
12	DC CHARACTERISTICS.....	41

13	AC CHARACTERISTICS.....	42
14	APPLICATION EXAMPLE	46
15	SSD1332U1R1 COF PACKAGE DIMENSIONS	47
16	SSD1332U1R1 COF PIN ASSIGNMENT	49
17	SSD1332T1R1 TAB PACKAGE DIMENSIONS.....	51
18	SSD1332T1R1 TAB PIN ASSIGNMENT.....	53
19	SSD1332Z PACKAGE DETAILS.....	55

TABLE OF FIGURES

Figure 1 - Block Diagram	7
Figure 2 – SSD1332Z Pin Assignment	8
Figure 3 - SSD1332Z Alignment mark dimensions.....	12
Figure 4 - Oscillator Circuit.....	16
Figure 5 – I _{REF} Current Setting by Resistor Value.....	17
Figure 6 – Segment and Common Driver Block Diagram.....	18
Figure 7 – Segment and Common Driver Signal Waveform.....	19
Figure 8 – Gray Scale Control by PWM in Segment	20
Figure 9 - Display data read back procedure - insertion of dummy read.....	21
Figure 10 – 65k Color Depth Graphic Display Data RAM Structure	22
Figure 11 – 65k Color Depth Graphic Display Data Writing Sequence	22
Figure 12 – 256 Color Depth Graphic Display Data RAM Structure for One Pixel.....	23
Figure 13 – Relation between graphic data RAM value and gray scale table entry for three colors in 65K color mode	23
Figure 14 – illustration of relation between graphic display RAM value and gray scale control.....	24
Figure 15 – DC-DC Converter Application Circuit Diagram.....	25
Figure 16 – Example of Column and Row Address Pointer Movement	31
Figure 17 – Segment Output Current for Different Contrast Control and Master Current Setting	32
Figure 18 – Address Pointer Movement of Horizontal Address Increment Mode.....	33
Figure 19 – Address Pointer Movement of Vertical Address Increment Mode.....	33
Figure 20 – Example of Set Display Start Line with no Remap.....	34
Figure 21 – Example of Set Display Offset with no Remap.....	34
Figure 22 – Example of gamma correction by gray scale table setting	36
Figure 23 – Example of Draw Line Command.....	38
Figure 24 – Example of Draw Rectangle Command	38
Figure 25 – Example of Copy Command	39
Figure 26 – Example of Copy + Clear = Move Command	40
Figure 27 - 6800-series MPU parallel interface characteristics	43
Figure 28 - 8080-series MPU parallel interface characteristics	44
Figure 29 - Serial interface characteristics.....	45
Figure 30 - Application Example for SSD1332U1R1	46
Figure 31 - SSD1332U1R1 COF pin assignment	49
Figure 32 - SSD1332T1R1 TAB pin assignment	53

LIST OF TABLES

Table 1 - Ordering Information	6
Table 2 - SSD1332Z Die Pad Coordinates	9
Table 3 – MCU Interface Selection Setting	13
Table 4 – Components Selection for DC-DC Converter	25
Table 5 – Configuration Command Table	26
Table 6 – Graphic Acceleration Command Set Table	29
Table 7 - Read Command Table	30
Table 8 - Address increment table (Automatic).....	30
Table 9 – Result of Change of Brightness by Dim Window Command	39
Table 10 - Maximum Ratings	41
Table 11 - DC Characteristics	41
Table 12 - AC Characteristics	42
Table 13 - 6800-Series MPU Parallel Interface Timing Characteristics	43
Table 14 - 8080-Series MPU Parallel Interface Timing Characteristics	44
Table 15 - Serial Interface Timing Characteristics	45
Table 16 - SSD1332U1R1 COF pin assignment	50
Table 17 - SSD1332T1R1 TAB pin assignment	54

1 GENERAL INFORMATION

The SSD1332 is a single-chip CMOS OLED/PLED driver with controller for organic/polymer light emitting diode dot-matrix graphic display system. It consists of 288 segments (96RGB) and 64 commons. This IC is designed for Common Cathode type OLED panel.

The SSD1332 displays data directly from its internal 96x64x16 bits Graphic Data RAM (GDDRAM). Data/Commands are sent from general MCU through the hardware selectable 6800/8000 series compatible Parallel Interface or Serial Peripheral Interface. It has a 256 steps contrast control and 65K color control.

2 FEATURES

- Support max. 96RGB x 64 matrix panel
- Power supply: $V_{DD} = 2.4V - 3.5V$
 $V_{CC} = 7.0V - 18.0V$
- OLED driving output voltage, 16V maximum
- DC-DC voltage converter
- Segment maximum source current: 200uA
- Common maximum sink current: 50mA
- Embedded 96x64x16 bit SRAM display buffer
- 16 step master current control, and 256 step current control for the three color components
- Programmable Frame Rate
- Graphic Acceleration Command Set (GAC)
- 8-bit 6800-series Parallel Interface, 8-bit 8080-series Parallel Interface, Serial Peripheral Interface.
- Wide range of operating temperature: -40 to 85 °C

3 ORDERING INFORMATION

Table 1 - Ordering Information

Ordering Part Number	SEG	COM	Package Form	Reference	Remark
SSD1332U1R1	96RGB	64	COF	Page 47	<ul style="list-style-type: none"> • 35mm film • 5 sprocket hole • 80 / 68 / SPI interface • SEG lead pitch 0.06mm • COM lead pitch 0.09mm
SSD1332T1R1	96RGB	64	TAB	Page 52	<ul style="list-style-type: none"> • 35mm film • 5 sprocket hole • Folding TAB • 80 / 68 / SPI interface • SEG lead pitch 0.06mm • COM lead pitch 0.09mm
SSD1332Z	96RGB	64	COG	Page 8	<ul style="list-style-type: none"> • Min SEG pad pitch: 41.2 μm • Min COM pad pitch: 41.2 μm

4 BLOCK DIAGRAM

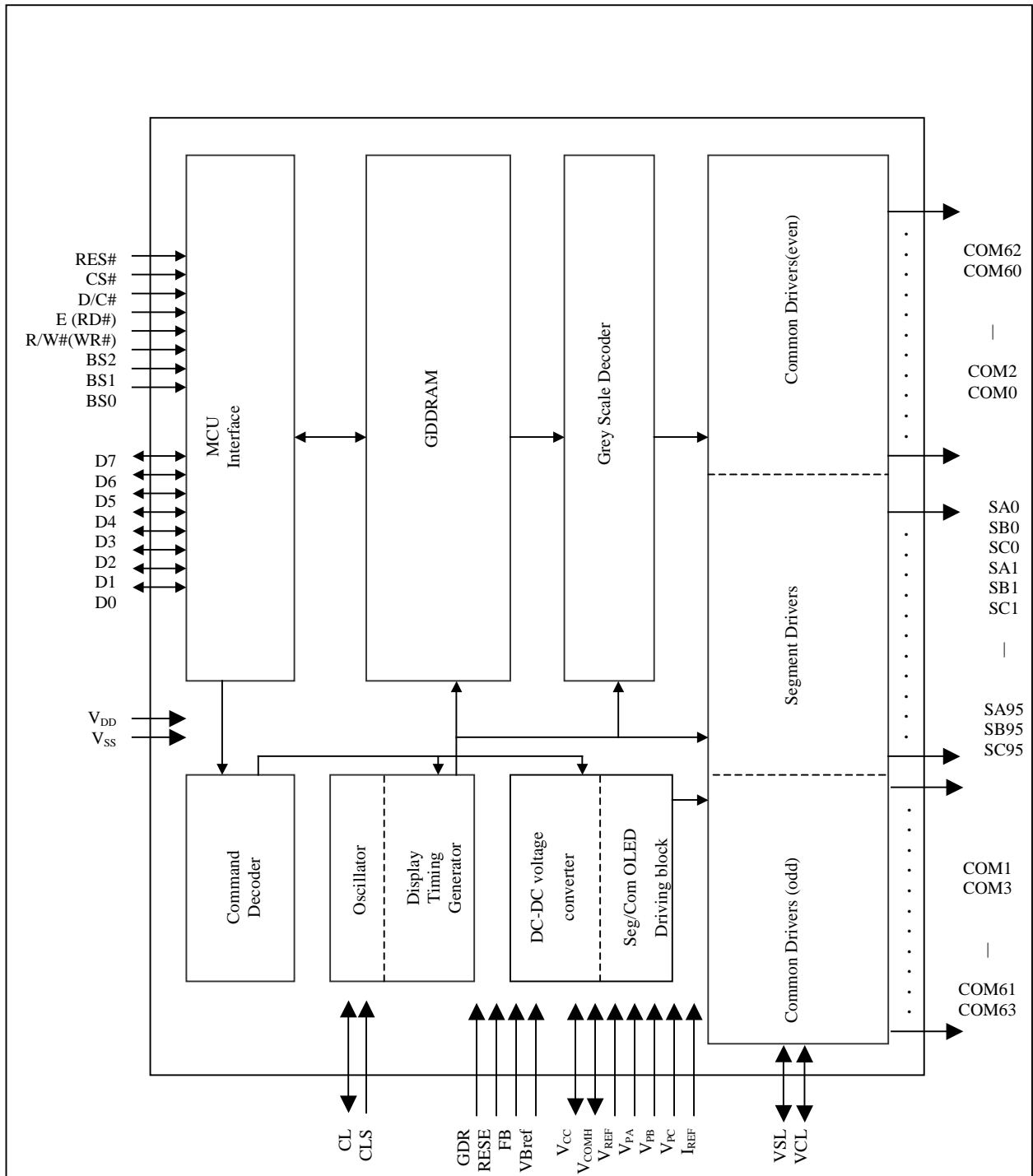
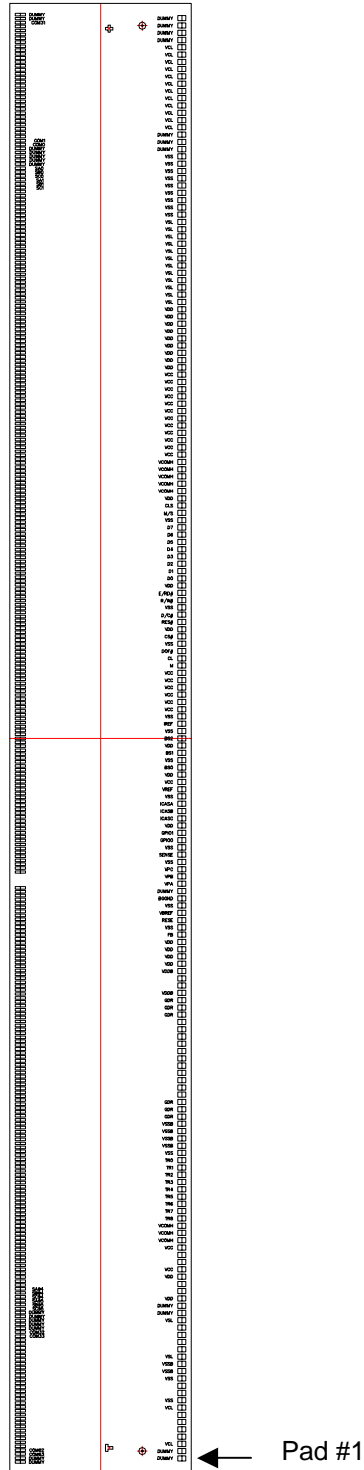





Figure 1 - Block Diagram

5 SSD1332Z GOLD BUMP DIE PAD ASSIGNMENT

Figure 2 – SSD1332Z Pin Assignment



+ represents the centre of the alignment mark

	X-pos (μm)	Y-pos (μm)
	-7433.6	-90.5
	7433.6	-90.5
	-7465.9	-437.4
	7465.9	-437.4

All alignment keys have size
75 μm x 75 μm

Die Size: 15.4mm x 1.9mm
Die Thickness: 457 +/- 25 μm
Min I/O pad pitch: 76.2 μm
Min SEG pad pitch: 41.2 μm
Min COM pad pitch: 41.2 μm
Bump Height: Nominal 15 μm

Table 2 - SSD1332Z Die Pad Coordinates

Pad #	Pad Name	X-Axis	Y-Axis	Pad #	Pad Name	X-Axis	Y-Axis	Pad #	Pad Name	X-Axis	Y-Axis	Pad #	Pad Name	X-Axis	Y-Axis
1	DUMMY	-7543.8	-853	61	GDR	-2971.8	-853	121	VDD	1600.2	-853	181	DUMMY	6172.2	-853
2	DUMMY	-7467.6	-853	62	GDR	-2895.6	-853	122	D0	1676.4	-853	182	DUMMY	6248.4	-853
3	VCL	-7391.4	-853	63	GDR	-2819.4	-853	123	D1	1752.6	-853	183	DUMMY	6324.6	-853
4	VCL	-7315.2	-853	64	GDR	-2743.2	-853	124	D2	1828.8	-853	184	VCL	6400.8	-853
5	VCL	-7239	-853	65	Vddb	-2667	-853	125	D3	1905	-853	185	VCL	6477	-853
6	VCL	-7162.8	-853	66	Vddb	-2590.8	-853	126	D4	1981.2	-853	186	VCL	6553.2	-853
7	VCL	-7086.6	-853	67	Vddb	-2514.6	-853	127	D5	2057.4	-853	187	VCL	6629.4	-853
8	VCL	-7010.4	-853	68	Vddb	-2438.4	-853	128	D6	2133.6	-853	188	VCL	6705.6	-853
9	VSS	-6934.2	-853	69	VDD	-2362.2	-853	129	D7	2209.8	-853	189	VCL	6781.8	-853
10	VSS	-6858	-853	70	VDD	-2286	-853	130	VSS	2286	-853	190	VCL	6858	-853
11	VSS	-6781.8	-853	71	VDD	-2209.8	-853	131	M/S	2362.2	-853	191	VCL	6934.2	-853
12	VSS	-6705.6	-853	72	VDD	-2133.6	-853	132	CLS	2438.4	-853	192	VCL	7010.4	-853
13	VSSB	-6629.4	-853	73	FB	-2057.4	-853	133	VDD	2514.6	-853	193	VCL	7086.6	-853
14	VSSB	-6553.2	-853	74	VSS	-1981.2	-853	134	VCOMH	2590.8	-853	194	VCL	7162.8	-853
15	VSL	-6477	-853	75	RESE	-1905	-853	135	VCOMH	2667	-853	195	VCL	7239	-853
16	VSL	-6400.8	-853	76	VBREF	-1828.8	-853	136	VCOMH	2743.2	-853	196	DUMMY	7315.2	-853
17	VSL	-6324.6	-853	77	VSS	-1752.6	-853	137	VCOMH	2819.4	-853	197	DUMMY	7391.4	-853
18	VSL	-6248.4	-853	78	BGGND	-1676.4	-853	138	VCOMH	2895.6	-853	198	DUMMY	7467.6	-853
19	VSL	-6172.2	-853	79	DUMMY	-1600.2	-853	139	VCC	2971.8	-853	199	DUMMY	7543.8	-853
20	VSL	-6096	-853	80	VPA	-1524	-853	140	VCC	3048	-853	200	DUMMY	7580.8	840
21	DUMMY	-6019.8	-853	81	VPB	-1447.8	-853	141	VCC	3124.2	-853	201	DUMMY	7539.6	840
22	DUMMY	-5943.6	-853	82	VPC	-1371.6	-853	142	VCC	3200.4	-853	202	COM31	7498.4	840
23	VDD	-5867.4	-853	83	VSS	-1295.4	-853	143	VCC	3276.6	-853	203	COM30	7457.2	840
24	VDD	-5791.2	-853	84	SENSE	-1219.2	-853	144	VCC	3352.8	-853	204	COM29	7416	840
25	VDD	-5715	-853	85	VSS	-1143	-853	145	VCC	3429	-853	205	COM28	7374.8	840
26	VDD	-5638.8	-853	86	GPIO0	-1066.8	-853	146	VCC	3505.2	-853	206	COM27	7333.6	840
27	VCC	-5562.6	-853	87	GPIO1	-990.6	-853	147	VCC	3581.4	-853	207	COM26	7292.4	840
28	VCC	-5486.4	-853	88	VDD	-914.4	-853	148	VCC	3657.6	-853	208	COM25	7251.2	840
29	VCC	-5410.2	-853	89	ICASC	-838.2	-853	149	VCC	3733.8	-853	209	COM24	7210	840
30	VCC	-5334	-853	90	ICASB	-762	-853	150	VCC	3810	-853	210	COM23	7168.8	840
31	VCOMH	-5257.8	-853	91	ICASA	-685.8	-853	151	VDD	3886.2	-853	211	COM22	7127.6	840
32	VCOMH	-5181.6	-853	92	VSSA	-609.6	-853	152	VDD	3962.4	-853	212	COM21	7086.4	840
33	VCOMH	-5105.4	-853	93	VREF	-533.4	-853	153	VDD	4038.6	-853	213	COM20	7045.2	840
34	TR8	-5029.2	-853	94	VCC	-457.2	-853	154	VDD	4114.8	-853	214	COM19	7004	840
35	TR7	-4953	-853	95	VDD	-381	-853	155	VDD	4191	-853	215	COM18	6962.8	840
36	TR6	-4876.8	-853	96	BS0	-304.8	-853	156	VDD	4267.2	-853	216	COM17	6921.6	840
37	TR5	-4800.6	-853	97	VSS	-228.6	-853	157	VDD	4343.4	-853	217	COM16	6880.4	840
38	TR4	-4724.4	-853	98	BS1	-152.4	-853	158	VDD	4419.6	-853	218	COM15	6839.2	840
39	TR3	-4648.2	-853	99	VDD	-76.2	-853	159	VDD	4495.8	-853	219	COM14	6798	840
40	TR2	-4572	-853	100	BS2	0	-853	160	VSL	4572	-853	220	COM13	6756.8	840
41	TR1	-4495.8	-853	101	VSS	76.2	-853	161	VSL	4648.2	-853	221	COM12	6715.6	840
42	TR0	-4419.6	-853	102	IREF	152.4	-853	162	VSL	4724.4	-853	222	COM11	6674.4	840
43	VSS	-4343.4	-853	103	VSS	228.6	-853	163	VSL	4800.6	-853	223	COM10	6633.2	840
44	VSSB	-4267.2	-853	104	VCC	304.8	-853	164	VSL	4876.8	-853	224	COM9	6592	840
45	VSSB	-4191	-853	105	VCC	381	-853	165	VSL	4953	-853	225	COM8	6550.8	840
46	VSSB	-4114.8	-853	106	VCC	457.2	-853	166	VSL	5029.2	-853	226	COM7	6509.6	840
47	VSSB	-4038.6	-853	107	VCC	533.4	-853	167	VSL	5105.4	-853	227	COM6	6468.4	840
48	GDR	-3962.4	-853	108	VCC	609.6	-853	168	VSL	5181.6	-853	228	COM5	6427.2	840
49	GDR	-3886.2	-853	109	VCC	685.8	-853	169	VSL	5257.8	-853	229	COM4	6386	840
50	GDR	-3810	-853	110	M	762	-853	170	VSL	5334	-853	230	COM3	6344.8	840
51	GDR	-3733.8	-853	111	CL	838.2	-853	171	VSL	5410.2	-853	231	COM2	6303.6	840
52	GDR	-3657.6	-853	112	DOF#	914.4	-853	172	VSS	5486.4	-853	232	COM1	6262.4	840
53	GDR	-3581.4	-853	113	VSS	990.6	-853	173	VSS	5562.6	-853	233	COM0	6221.2	840
54	GDR	-3505.2	-853	114	CS#	1066.8	-853	174	VSS	5638.8	-853	234	DUMMY	6180	840
55	GDR	-3429	-853	115	VDD	1143	-853	175	VSS	5715	-853	235	DUMMY	6138.8	840
56	GDR	-3352.8	-853	116	RES#	1219.2	-853	176	VSS	5791.2	-853	236	DUMMY	6097.6	840
57	GDR	-3276.6	-853	117	D/C#	1295.4	-853	177	VSS	5867.4	-853	237	DUMMY	6056.4	840
58	GDR	-3200.4	-853	118	VSS	1371.6	-853	178	VSS	5943.6	-853	238	DUMMY	6015.2	840
59	GDR	-3124.2	-853	119	R/W#	1447.8	-853	179	VSS	6019.8	-853	239	SA0	5974	840
60	GDR	-3048	-853	120	E/RD#	1524	-853	180	VSS	6096	-853	240	SB0	5932.8	840

Pad #	Pad Name	X-Axis	Y-Axis
241	SC0	5891.6	840
242	SA1	5850.4	840
243	SB1	5809.2	840
244	SC1	5768	840
245	SA2	5726.8	840
246	SB2	5685.6	840
247	SC2	5644.4	840
248	SA3	5603.2	840
249	SB3	5562	840
250	SC3	5520.8	840
251	SA4	5479.6	840
252	SB4	5438.4	840
253	SC4	5397.2	840
254	SA5	5356	840
255	SB5	5314.8	840
256	SC5	5273.6	840
257	SA6	5232.4	840
258	SB6	5191.2	840
259	SC6	5150	840
260	SA7	5108.8	840
261	SB7	5067.6	840
262	SC7	5026.4	840
263	SA8	4985.2	840
264	SB8	4944	840
265	SC8	4902.8	840
266	SA9	4861.6	840
267	SB9	4820.4	840
268	SC9	4779.2	840
269	SA10	4738	840
270	SB10	4696.8	840
271	SC10	4655.6	840
272	SA11	4614.4	840
273	SB11	4573.2	840
274	SC11	4532	840
275	SA12	4490.8	840
276	SB12	4449.6	840
277	SC12	4408.4	840
278	SA13	4367.2	840
279	SB13	4326	840
280	SC13	4284.8	840
281	SA14	4243.6	840
282	SB14	4202.4	840
283	SC14	4161.2	840
284	SA15	4120	840
285	SB15	4078.8	840
286	SC15	4037.6	840
287	SA16	3996.4	840
288	SB16	3955.2	840
289	SC16	3914	840
290	SA17	3872.8	840
291	SB17	3831.6	840
292	SC17	3790.4	840
293	SA18	3749.2	840
294	SB18	3708	840
295	SC18	3666.8	840
296	SA19	3625.6	840
297	SB19	3584.4	840
298	SC19	3543.2	840
299	SA20	3502	840
300	SB20	3460.8	840

Pad #	Pad Name	X-Axis	Y-Axis
301	SC20	3419.6	840
302	SA21	3378.4	840
303	SB21	3337.2	840
304	SC21	3296	840
305	SA22	3254.8	840
306	SB22	3213.6	840
307	SC22	3172.4	840
308	SA23	3131.2	840
309	SB23	3090	840
310	SC23	3048.8	840
311	SA24	3007.6	840
312	SB24	2966.4	840
313	SC24	2925.2	840
314	SA25	2884	840
315	SB25	2842.8	840
316	SC25	2801.6	840
317	SA26	2760.4	840
318	SB26	2719.2	840
319	SC26	2678	840
320	SA27	2636.8	840
321	SB27	2595.6	840
322	SC27	2554.4	840
323	SA28	2513.2	840
324	SB28	2472	840
325	SC28	2430.8	840
326	SA29	2389.6	840
327	SB29	2348.4	840
328	SC29	2307.2	840
329	SA30	2266	840
330	SB30	2224.8	840
331	SC30	2183.6	840
332	SA31	2142.4	840
333	SB31	2101.2	840
334	SC31	2060	840
335	SA32	2018.8	840
336	SB32	1977.6	840
337	SC32	1936.4	840
338	SA33	1895.2	840
339	SB33	1854	840
340	SC33	1812.8	840
341	SA34	1771.6	840
342	SB34	1730.4	840
343	SC34	1689.2	840
344	SA35	1648	840
345	SB35	1606.8	840
346	SC35	1565.6	840
347	SA36	1524.4	840
348	SB36	1483.2	840
349	SC36	1442	840
350	SA37	1400.8	840
351	SB37	1359.6	840
352	SC37	1318.4	840
353	SA38	1277.2	840
354	SB38	1236	840
355	SC38	1194.8	840
356	SA39	1153.6	840
357	SB39	1112.4	840
358	SC39	1071.2	840
359	SA40	1030	840
360	SB40	988.8	840

Pad #	Pad Name	X-Axis	Y-Axis
361	SC40	947.6	840
362	SA41	906.4	840
363	SB41	865.2	840
364	SC41	824	840
365	SA42	782.8	840
366	SB42	741.6	840
367	SC42	700.4	840
368	SA43	659.2	840
369	SB43	618	840
370	SC43	576.8	840
371	SA44	535.6	840
372	SB44	494.4	840
373	SC44	453.2	840
374	SA45	412	840
375	SB45	370.8	840
376	SC45	329.6	840
377	SA46	288.4	840
378	SB46	247.2	840
379	SC46	206	840
380	SA47	164.8	840
381	SB47	123.6	840
382	SC47	82.4	840
383	SA48	41.2	840
384	SB48	0	840
385	SC48	-41.2	840
386	SA49	-82.4	840
387	SB49	-123.6	840
388	SC49	-164.8	840
389	SA50	-206	840
390	SB50	-247.2	840
391	SC50	-288.4	840
392	SA51	-329.6	840
393	SB51	-370.8	840
394	SC51	-412	840
395	SA52	-453.2	840
396	SB52	-494.4	840
397	SC52	-535.6	840
398	SA53	-576.8	840
399	SB53	-618	840
400	SC53	-659.2	840
401	SA54	-700.4	840
402	SB54	-741.6	840
403	SC54	-782.8	840
404	SA55	-824	840
405	SB55	-865.2	840
406	SC55	-906.4	840
407	SA56	-947.6	840
408	SB56	-988.8	840
409	SC56	-1030	840
410	SA57	-1071.2	840
411	SB57	-1112.4	840
412	SC57	-1153.6	840
413	SA58	-1194.8	840
414	SB58	-1236	840
415	SC58	-1277.2	840
416	SA59	-1318.4	840
417	SB59	-1359.6	840
418	SC59	-1400.8	840
419	SA60	-1565.6	840
420	SB60	-1606.8	840

Pad #	Pad Name	X-Axis	Y-Axis
421	SC60	-1648	840
422	SA61	-1689.2	840
423	SB61	-1730.4	840
424	SC61	-1771.6	840
425	SA62	-1812.8	840
426	SB62	-1854	840
427	SC62	-1895.2	840
428	SA63	-1936.4	840
429	SB63	-1977.6	840
430	SC63	-2018.8	840
431	SA64	-2060	840
432	SB64	-2101.2	840
433	SC64	-2142.4	840
434	SA65	-2183.6	840
435	SB65	-2224.8	840
436	SC65	-2266	840
437	SA66	-2307.2	840
438	SB66	-2348.4	840
439	SC66	-2389.6	840
440	SA67	-2430.8	840
441	SB67	-2472	840
442	SC67	-2513.2	840
443	SA68	-2554.4	840
444	SB68	-2595.6	840
445	SC68	-2636.8	840
446	SA69	-2678	840
447	SB69	-2719.2	840
448	SC69	-2760.4	840
449	SA70	-2801.6	840
450	SB70	-2842.8	840
451	SC70	-2884	840
452	SA71	-2925.2	840
453	SB71	-2966.4	840
454	SC71	-3007.6	840
455	SA72	-3048.8	840
456	SB72	-3090	840
457	SC72	-3131.2	840
458	SA73	-3172.4	840
459	SB73	-3213.6	840
460	SC73	-3254.8	840
461	SA74	-3296	840
462	SB74	-3337.2	840
463	SC74	-3378.4	840
464	SA75	-3419.6	840
465	SB75	-3460.8	840
466	SC75	-3502	840
467	SA76	-3543.2	840
468	SB76	-3584.4	840
469	SC76	-3625.6	840
470	SA77	-3666.8	840
471	SB77	-3708	840
472	SC77	-3749.2	840
473	SA78	-3790.4	840
474	SB78	-3831.6	840
475	SC78	-3872.8	840
476	SA79	-3914	840
477	SB79	-3955.2	840
478	SC79	-3996.4	840
479	SA80	-4037.6	840
480	SB80	-4078.8	840

Pad #	Pad Name	X-Axis	Y-Axis
481	SC80	-4120	840
482	SA81	-4161.2	840
483	SB81	-4202.4	840
484	SC81	-4243.6	840
485	SA82	-4284.8	840
486	SB82	-4326	840
487	SC82	-4367.2	840
488	SA83	-4408.4	840
489	SB83	-4449.6	840
490	SC83	-4490.8	840
491	SA84	-4532	840
492	SB84	-4573.2	840
493	SC84	-4614.4	840
494	SA85	-4655.6	840
495	SB85	-4696.8	840
496	SC85	-4738	840
497	SA86	-4779.2	840
498	SB86	-4820.4	840
499	SC86	-4861.6	840
500	SA87	-4902.8	840
501	SB87	-4944	840
502	SC87	-4985.2	840
503	SA88	-5026.4	840
504	SB88	-5067.6	840
505	SC88	-5108.8	840
506	SA89	-5150	840
507	SB89	-5191.2	840
508	SC89	-5232.4	840
509	SA90	-5273.6	840
510	SB90	-5314.8	840
511	SC90	-5356	840
512	SA91	-5397.2	840
513	SB91	-5438.4	840
514	SC91	-5479.6	840
515	SA92	-5520.8	840
516	SB92	-5562	840
517	SC92	-5603.2	840
518	SA93	-5644.4	840
519	SB93	-5685.6	840
520	SC93	-5726.8	840
521	SA94	-5768	840
522	SB94	-5809.2	840
523	SC94	-5850.4	840
524	SA95	-5891.6	840
525	SB95	-5932.8	840
526	SC95	-5974	840
527	DUMMY	-6015.2	840
528	DUMMY	-6056.4	840
529	DUMMY	-6097.6	840
530	DUMMY	-6138.8	840
531	DUMMY	-6180	840
532	COM32	-6221.2	840
533	COM33	-6262.4	840
534	COM34	-6303.6	840
535	COM35	-6344.8	840
536	COM36	-6386	840
537	COM37	-6427.2	840
538	COM38	-6468.4	840
539	COM39	-6509.6	840
540	COM40	-6550.8	840

Pad #	Pad Name	X-Axis	Y-Axis
541	COM41	-6592	840
542	COM42	-6633.2	840
543	COM43	-6674.4	840
544	COM44	-6715.6	840
545	COM45	-6756.8	840
546	COM46	-6798	840
547	COM47	-6839.2	840
548	COM48	-6880.4	840
549	COM49	-6921.6	840
550	COM50	-6962.8	840
551	COM51	-7004	840
552	COM52	-7045.2	840
553	COM53	-7086.4	840
554	COM54	-7127.6	840
555	COM55	-7168.8	840
556	COM56	-7210	840
557	COM57	-7251.2	840
558	COM58	-7292.4	840
559	COM59	-7333.6	840
560	COM60	-7374.8	840
561	COM61	-7416	840
562	COM62	-7457.2	840
563	COM63	-7498.4	840
564	DUMMY	-7539.6	840
565	DUMMY	-7580.8	840

	Width (um)	Length (um)
Die Size (after saw)	15400	1900
Top Side	27	110
Bottom side	54	84

Figure 3 - SSD1332Z Alignment mark dimensions

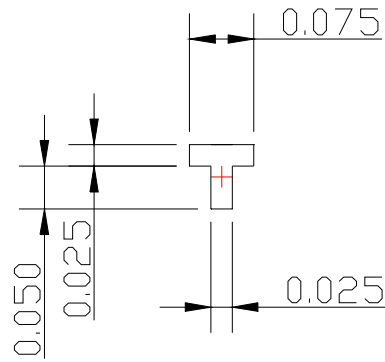

T shape

Detail T

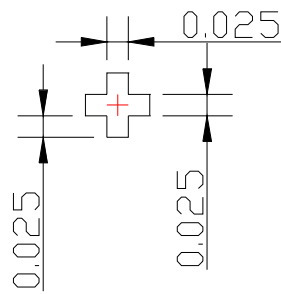

+ shape

Detail +

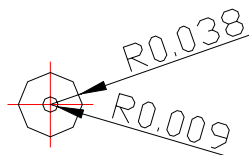

Circle

Detail □

Scale: 10:1

Unit in um

6 PIN DESCRIPTION

BS0, BS1, BS2

These input pins are used to configure MCU interface selection by appropriate logic setting, which is described in the following table:

Table 3 – MCU Interface Selection Setting

	6800-parallel interface (8 bit)	8080-parallel interface (8 bit)	Serial interface
BS0	0	0	0
BS1	0	1	0
BS2	1	1	0

CS#

This pin is the chip select input. The chip is enabled for MCU communication only when CS# is pulled low.

RES#

This pin is reset signal input. When the pin is low, initialization of the chip is executed.

D/C

This pin is Data/Command control pin. When the pin is pulled high, the data at D₇-D₀ is treated as display data. When the pin is pulled low, the data at D₇-D₀ will be transferred to the command register. For detail relationship to MCU interface signals, please refer to the Timing Characteristics Diagrams.

R/W(WR#)

This pin is MCU interface input. When interfacing to a 6800-series microprocessor, this pin will be used as Read/Write (R/W) selection input. Read mode will be carried out when this pin is pulled high and write mode when low.

When 8080 interface mode is selected, this pin will be the Write (WR#) input. Data write operation is initiated when this pin is pulled low and the chip is selected.

When serial interface is selected, this pin E(RD#) must be connected to VSS.

E (RD#)

This pin is MCU interface input. When interfacing to a 6800-series microprocessor, this pin will be used as the Enable (E) signal. Read/write operation is initiated when this pin is pulled high and the chip is selected.

When connecting to an 8080-microprocessor, this pin receives the Read (RD#) signal. Data read operation is initiated when this pin is pulled low and the chip is selected.

When serial interface is selected, this pin E(RD#) must be connected to VSS.

D₇-D₀

These pins are 8-bit bi-directional data bus to be connected to the microprocessor's data bus.

V_{DD}

Power Supply pin for logic operation of the driver. It must be connected to external source.

V_{SS}

Ground pin. It must be connected to external ground.

V_{CC}

This is the most positive voltage supply pin of the chip. It is supplied either by external high voltage source or internal booster

V_{REF}

This pin is the reference for OLED driving voltages like V_{PA}, V_{PB}, V_{PC} and V_{COMH}. The relation between V_{REF} and those driving voltages can be programmed and please refer to section "Command Table" for details. V_{REF} can be either supplied externally or connected to V_{CC}.

V_{PA}, V_{PB}, V_{PC}

These pins are the pre-charge driving voltages for OLED driving segment pins SA0-SA95, SB0-SB95 and SC0-SC95 respectively. They can be supplied externally or internally generated by VP circuit. When internal VP is used, V_{PA}, V_{PB}, V_{PC} pins should be left open.

I_{REF}

This pin is the segment output current reference pin. I_{SEG} is derived from I_{REF}

$$I_{SEG} = \text{Contrast} / 256 * I_{REF} * \text{scale factor},$$

in which the contrast is set by command and the scale factor = 1 ~ 16.

A resistor should be connected between this pin and V_{SS} to maintain the current around 10uA. Please refer to section 6 "Current and Voltage Supply" for the formula of resistor value from I_{REF}.

V_{COMH}

This pin is the input pin for the voltage output high level for COM signals. It can be supplied externally or internally. When V_{COMH} is generated internally, a capacitor should be connected between this pin and V_{SS}.

V_{DDB}

This is the power supply pin for the internal buffer of the DC-DC voltage converter. $3.5V \geq V_{DDB} \geq V_{DD}$.

V_{SSB}

This is the GND pin for the internal buffer of the DC-DC voltage converter. It must be connected to V_{SS}.

GDR

This output pin drives the gate of the external NMOS of the booster circuit. Please refer to the DC-DC voltage converter section for connection details.

RESE

This pin connects to the source current pin of the external NMOS of the booster circuit. Please refer to the DC-DC voltage converter section for connection details.

V_{BREF}

This pin is the internal voltage reference of booster circuit. A stabilization capacitor, typically 1uF, should be connected between V_{BREF} and V_{SS}.

FB

This pin is the feedback resistor input of the booster circuit. It is used to adjust the booster output voltage level (Vcc). Please refer to the DC-DC voltage converter section for connection details.

COM0-COM63

These pins provide the Common switch signals to the OLED panel. These pins are in high impedance state when display is off.

SA0-SA95, SB0-SB95, SC0-SC95

These pins provide the OLED segment driving signals. These pins are in high impedance state when display is off.

The 288 segment pins are divided into 3 groups, SA, SB and SC. Each group can have different color settings for color A, B and C.

7 FUNCTIONAL BLOCK DESCRIPTIONS

Oscillator Circuit and Display Time Generator

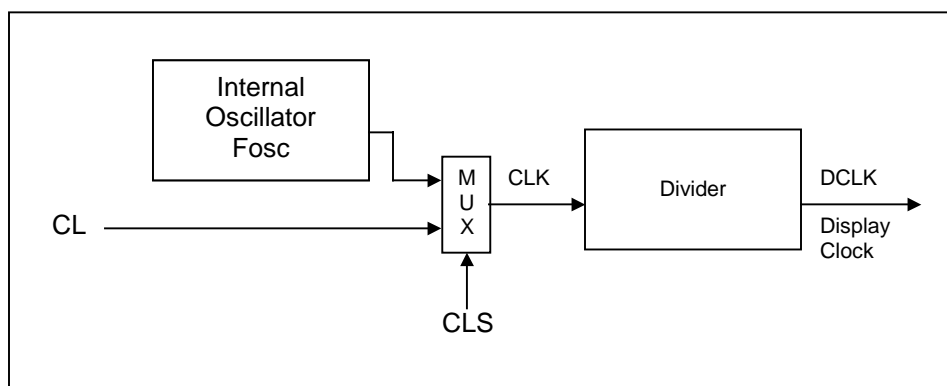

Figure 4 - Oscillator Circuit

This module is an On-Chip low power RC oscillator circuitry (Figure 4). The operation clock (CLK) can be generated either from internal oscillator or external source CL pin by CLS pin. If CLS pin is high, internal oscillator is selected. If CLS pin is low, external clock from CL pin will be used for CLK. The frequency of internal oscillator Fosc can be programmed by command B3h.

The display clock (DCLK) for the Display Timing Generator is derived from CLK. The division factor can be programmed from 1 to 16 by command B3h.

Reset Circuit

When RES# input is low, the chip is initialized with the following status:

1. Display is OFF
2. 64 MUX Display Mode
3. Normal segment and display data column address and row address mapping (SEG0 mapped to address 00H and COM0 mapped to address 00H)
4. Shift register data clear in serial interface
5. Display start line is set at display RAM address 0
6. Column address counter is set at 0
7. Normal scan direction of the COM outputs
8. Master contrast control register is set at 0FH
9. Individual contrast control registers of color A, B, and C are set at 80H

Command Decoder and Command Interface

This module determines whether the input data is interpreted as data or command. Data is interpreted based upon the input of the D/C# pin.

If D/C# pin is high, data is written to Graphic Display Data RAM (GDDRAM). If it is low, the input at D₀-D₇ is interpreted as a Command and it will be decoded and be written to the corresponding command register.

Current and Voltage Supply

This block is used to derive the incoming power sources into the different levels of internal use voltage and current.

- V_{CC} are most positive voltage supply. It can be supplied externally or from internal DC-DC converter.
- V_{DD} are external power supply for logic operation of the driver.
- V_{REF} is reference voltage, which is used to derive driving voltage for segments and commons like V_{PA} , V_{PB} , V_{PC} and V_{COMH} . Normally, V_{REF} is connected to V_{CC} . Please refer to the command table for the relationships of V_{REF} to the segments and commons voltages.
- I_{REF} is a reference current source for segment current drivers I_{SEG} . The relationship between reference current and segment current of a color is:

$$I_{SEG} = \text{Contrast} / 256 * I_{REF} * \text{scale factor}$$

in which the contrast (0~255) is set by Set Contrast command,
and the scale factor (1 ~ 16) is set by Master Current Control command.

For example, in order to achieve $I_{SEG} = 160\mu\text{A}$ at maximum contrast 255, I_{REF} is set to around $10\mu\text{A}$. This current value is obtained by connecting an appropriate resistor from I_{REF} pin to V_{SS} as shown in Figure 5.

Recommended range for $I_{ref} = 8 - 12\mu\text{A}$

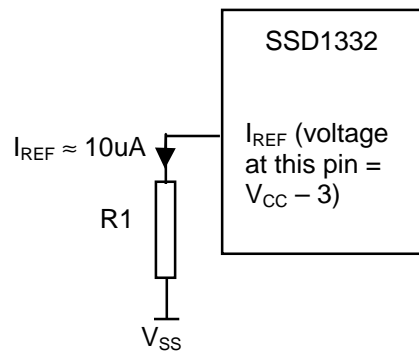

Figure 5 – I_{REF} Current Setting by Resistor Value

Since the voltage at I_{REF} pin is $V_{CC} - 3\text{V}$, the value of resistor $R1$ can be found as below.
 $R1 = (\text{Voltage at } I_{REF} - V_{SS}) / I_{REF} = (V_{CC} - 3) / 10\mu\text{A} \approx 910\text{k}\Omega$ for $V_{CC} = 12\text{V}$.

Segment Drivers/Common Drivers

Segment drivers consists of 288 (96 x 3 colors) current sources to drive OLED panel. The driving current can be adjusted from 0 to 200uA with 256 steps by contrast setting command. Common drivers generate scanning voltage pulse. The block diagrams and waveforms of the segment and common driver are shown as follow.

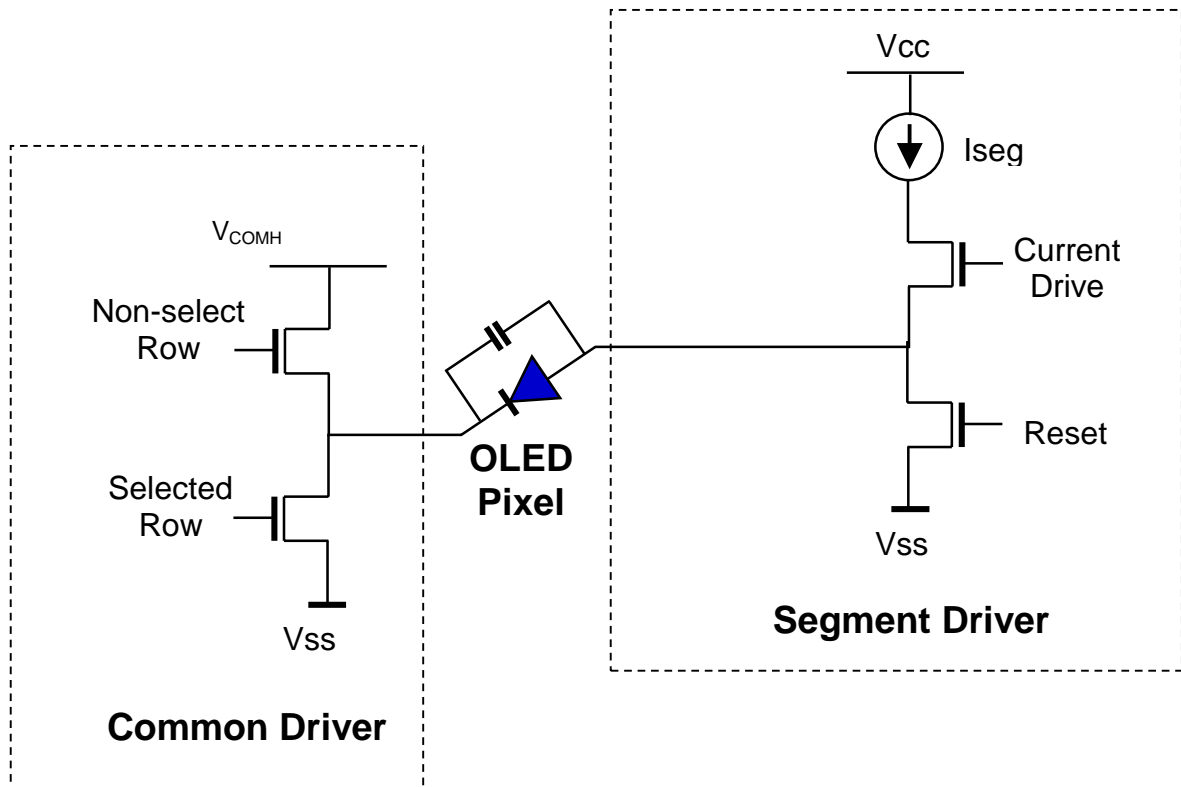

Figure 6 – Segment and Common Driver Block Diagram

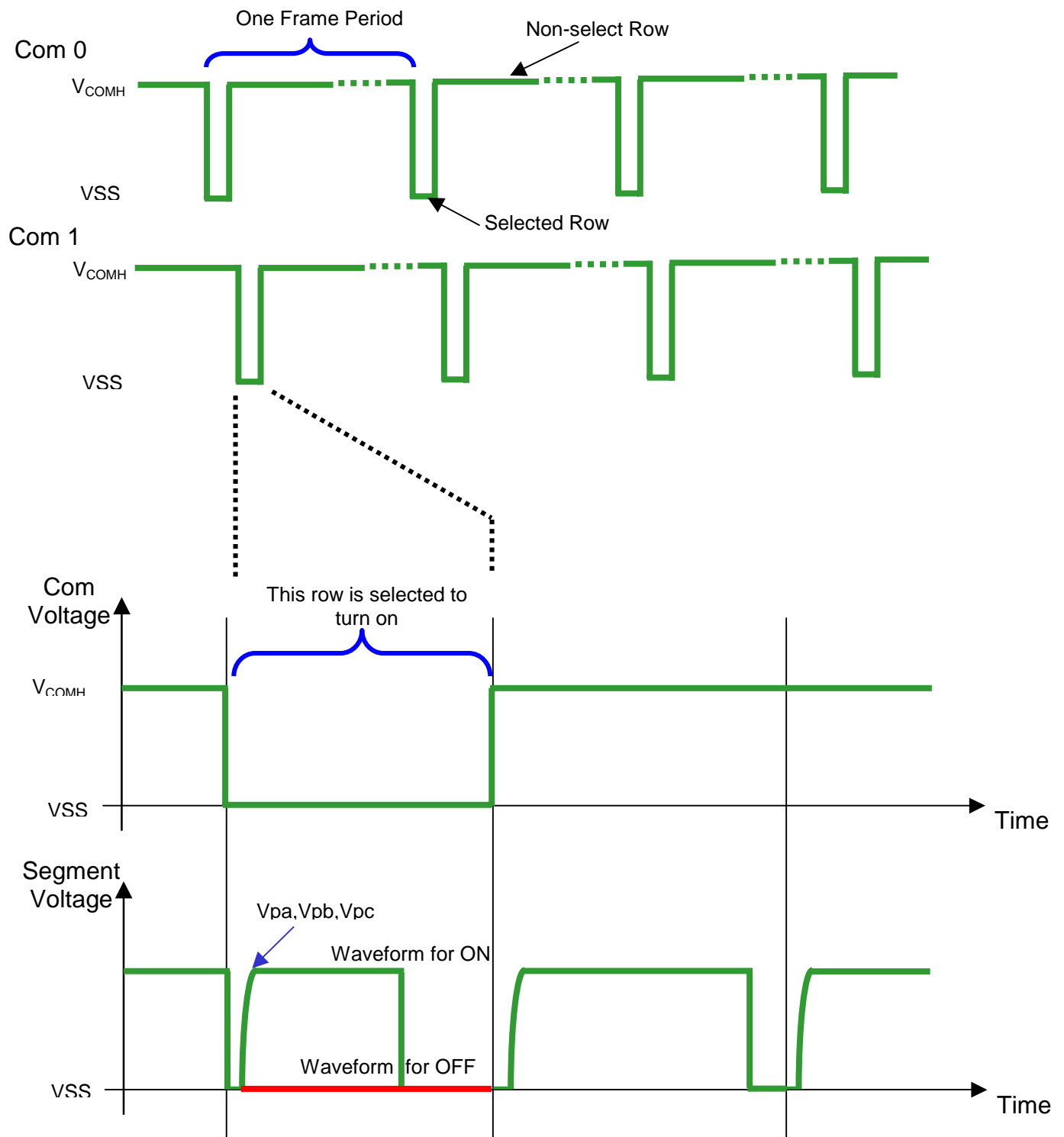

Figure 7 – Segment and Common Driver Signal Waveform

The commons are scanned sequentially one by one row. If the row is not selected, all the pixels on the row are in reverse bias by driving those commons to voltage V_{COMH} .

In the scanned row, the pixels on the row will be turned on or off by sending the corresponding data signal to the segment pins. If the pixel is turned off, the segment current is kept at 0. On the other hand, the segment drives to I_{SEG} when the pixel is turned on.

There are three phases to driving a OLED a pixel. In phase 1, the pixel is reset by the segment driver to V_{SS} in order to discharge the previous data charge stored in the parasitic capacitance along the segment electrode. The period of phase 1 can be programmed by command B1h from 1 to 16 DCLK. An OLED panel with larger capacitance requires a longer period for discharging.

In phase 2, the pixel is charged up by the segment driver to the desired voltage levels V_{PA} , V_{PB} or V_{PC} for color A, B or C respectively. The period of phase 2 can be programmed by command B1h from 1 to 16 DCLK. An OLED panel with larger capacitance requires a longer period for charging up.

Last phase is current drive stage. The current source in the segment driver delivers constant current to the pixel. The driver IC employs PWM (Pulse Width Modulation) method to control the gray scale of each pixel individually. The wider pulse widths in the current drive stage results in brighter pixels and vice versa. This is shown in the following figure.

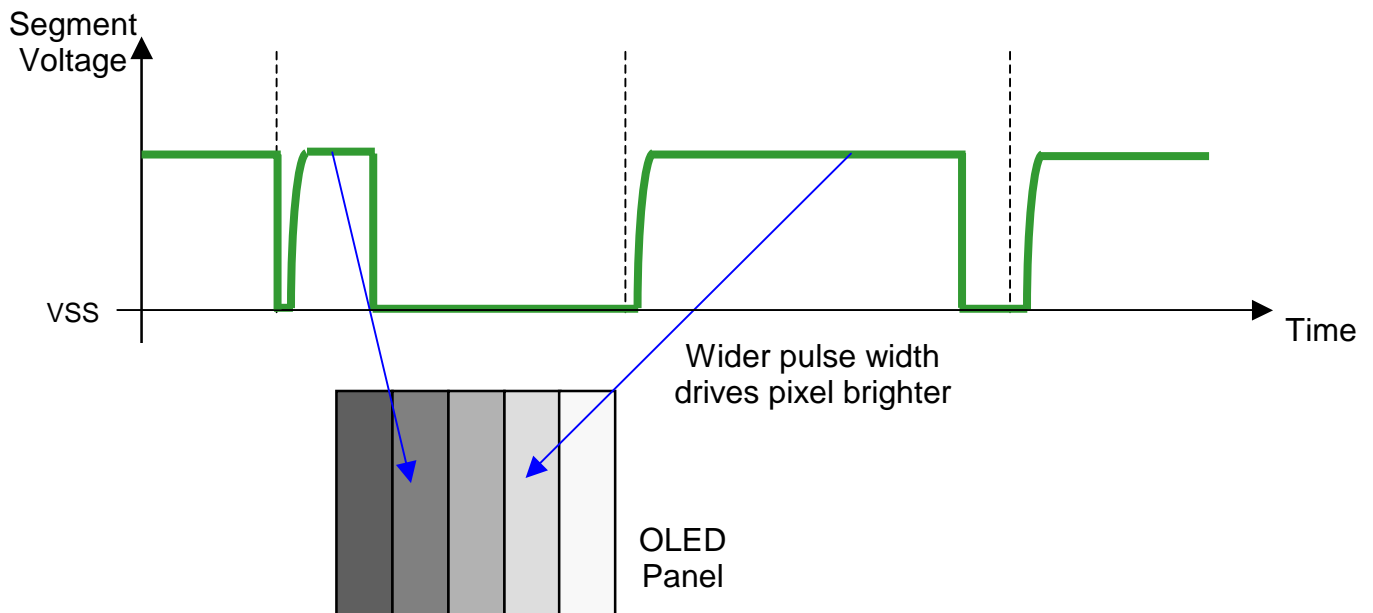

Figure 8 – Gray Scale Control by PWM in Segment

The pulse width in current drive stage to control brightness can be programmed through “Set Gray Scale Table” command. It is described in more detailed in “Command Descriptions” section.

MPU Parallel 6800-series Interface

The parallel interface consists of 8 bi-directional data pins (D_0 - D_7), $R/W(WR\#)$, D/C , $E(RD\#)$ and $CS\#$. $R/W(WR\#)$ High Input indicates a read operation from the Graphic Display Data RAM (GDDRAM) or the status register. $R/W(WR\#)$ Low Input indicates a write operation to Display Data RAM or Internal Command Registers depending on the status of D/C input. The $E(RD\#)$ input serves as data latch signal (clock) when high provided that $CS\#$ is low. Refer to Figure 27 of parallel timing characteristics for Parallel Interface Timing Diagram of 6800-series microprocessors.

In order to match the operating frequency of display RAM with that of the microprocessor, some pipeline processing is internally performed which requires the insertion of a dummy read before the first actual display data read. This is shown in Figure 9 below.

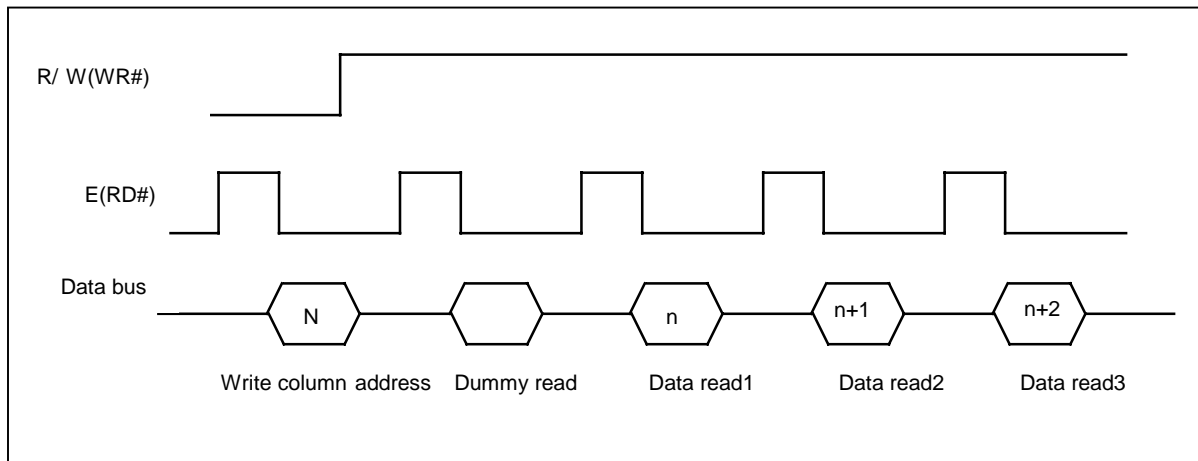

Figure 9 - Display data read back procedure - insertion of dummy read

MPU Parallel 8080-series Interface

The parallel interface consists of 8 bi-directional data pins (D_0 - D_7), $E(RD\#)$, $R/W(WR\#)$, D/C and $CS\#$. The $E(RD\#)$ input serves as data read latch signal (clock) when low, provided that $CS\#$ is low. Display data RAM or status register read is controlled by $D/C\#$.

$R/W(WR\#)$ input serves as data write latch signal (clock) when low provided that $CS\#$ is low, or $CS\#$ input serves as data write latch signal at rising edge when $R/W(WR\#)$ is low. Display data RAM or command register write is controlled by D/C . Refer to Figure 28 of parallel timing characteristics for Parallel Interface Timing Diagram of 8080-series microprocessor. Similar to 6800-series interface, a dummy read is also required before the first actual display data read.

MPU Serial Interface

The serial interface consists of serial clock $SCLK$, serial data $SDIN$, $D/C\#$, $CS\#$. In SPI mode, D_0 acts as $SCLK$, D_1 acts as $SDIN$. For the unused data pins, D_2 should be left open. D_3 to D_7 , E and R/W pins can be connected to external ground.

$SDIN$ is shifted into an 8-bit shift register on every rising edge of $SCLK$ in the order of D_7 , D_6 , ... D_0 . $D/C\#$ is sampled on every eighth clock and the data byte in the shift register is written to the Display Data RAM or command register in the same clock.

Graphic Display Data RAM (GDDRAM)

The GDDRAM is a bit mapped static RAM holding the pattern to be displayed. The size of the RAM is 96 x 64 x 16bits.

For mechanical flexibility, re-mapping on both Segment and Common outputs can be selected by software.

For vertical scrolling of the display, an internal register storing display start line can be set to control the portion of the RAM data to be mapped to the display.

Each pixel has 16-bit data. Three sub-pixels for color A, B and C have 6 bits, 5 bits and 6 bits respectively. The arrangement of data pixel in graphic display data RAM is shown below.

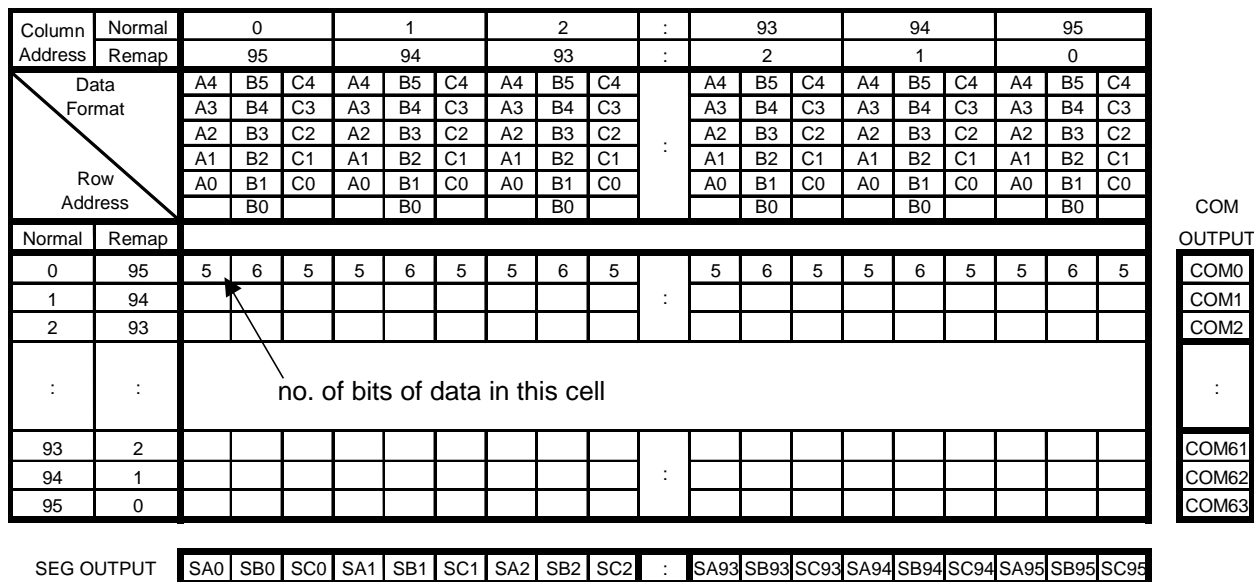

Figure 10 – 65k Color Depth Graphic Display Data RAM Structure

The sequence of sending one pixel of 16-bit data is divided into two 8-bit sessions as shown below.

	Bit 7	Bit 6	Bit 5	Bit 4	Bit 3	Bit 2	Bit 1	Bit 0
1 st byte	C4	C3	C2	C1	C0	B5	B4	B3
2 nd byte	B2	B1	B0	A4	A3	A2	A1	A0

Figure 11 – 65k Color Depth Graphic Display Data Writing Sequence

In 256-color mode, each pixel is composed of 8-bit. Color A uses 2-bit while color B and color C each is represented by 3-bit. Although only 8 bits are required to represent one pixel, each pixel occupies 16-bit space inside graphic display data RAM with format as follows.

For 256-color mode, one pixel data is sent in a 8-bit session like below.

	Bit 7	Bit 6	Bit 5	Bit 4	Bit 3	Bit 2	Bit 1	Bit 0
1 st byte	C2	C1	C0	B2	B1	B0	A1	A0

Figure 11 – 256 Color Depth Graphic Display Data Writing Sequence

Color C (3 bits)	RAM Content (5 bits)	Color B (3 bits)	RAM Content (6 bits)	Color A (2 bits)	RAM Content (5 bits)
000	00000	000	000000	00	00000
001	00100	001	001000	01	01000
010	01000	010	010000	10	10100
011	01100	011	011000	11	11100
100	10010	100	100100		
101	10110	101	101100		
110	11010	110	110100		
111	11110	111	111100		

Figure 12 – 256 Color Depth Graphic Display Data RAM Structure for One Pixel

Gray Scale and Gray Scale Table

The gray scale display is produced by controlling the current pulse widths from the segment driver in the current drive phase. The gray scale table stores the corresponding pulse widths (PW0 ~ PW63) of the 64 gray scale levels (GS0~GS63). The wider the pulse width, the brighter the pixel will be. This single gray scale table supports all the three colors A, B and C. The pulse widths are entered by software commands.

As shown in figure 13, color B sub-pixel RAM data has 6 bits, represent the 64 gray scale levels from GS0 to GS63. color A and color C sub-pixel RAM data has only 5 bits, represent 32 gray scale levels from GS0, GS2, ..., GS62.

Color A, C RAM data (5 bits)	Color B RAM data (6 bits)	Gray Scale
0	0	GS0
-	1	GS 1
1	2	GS 2
-	3	GS 3
2	4	GS 4
:	:	:
:	:	:
:	:	:
30	60	GS 60
-	61	GS 61
31	62	GS 62
-	63	GS 63

Figure 13 – Relation between graphic data RAM value and gray scale table entry for three colors in 65K color mode

The meaning of values inside data RAM with respect to the gray scale level is best to be illustrated in an example below.

Gray Scale (Pulse Width)	Value/DCLKs
PW0	0
PW1	2
PW2	5
:	:
PW62	120
PW63	125

Gray Scale Table

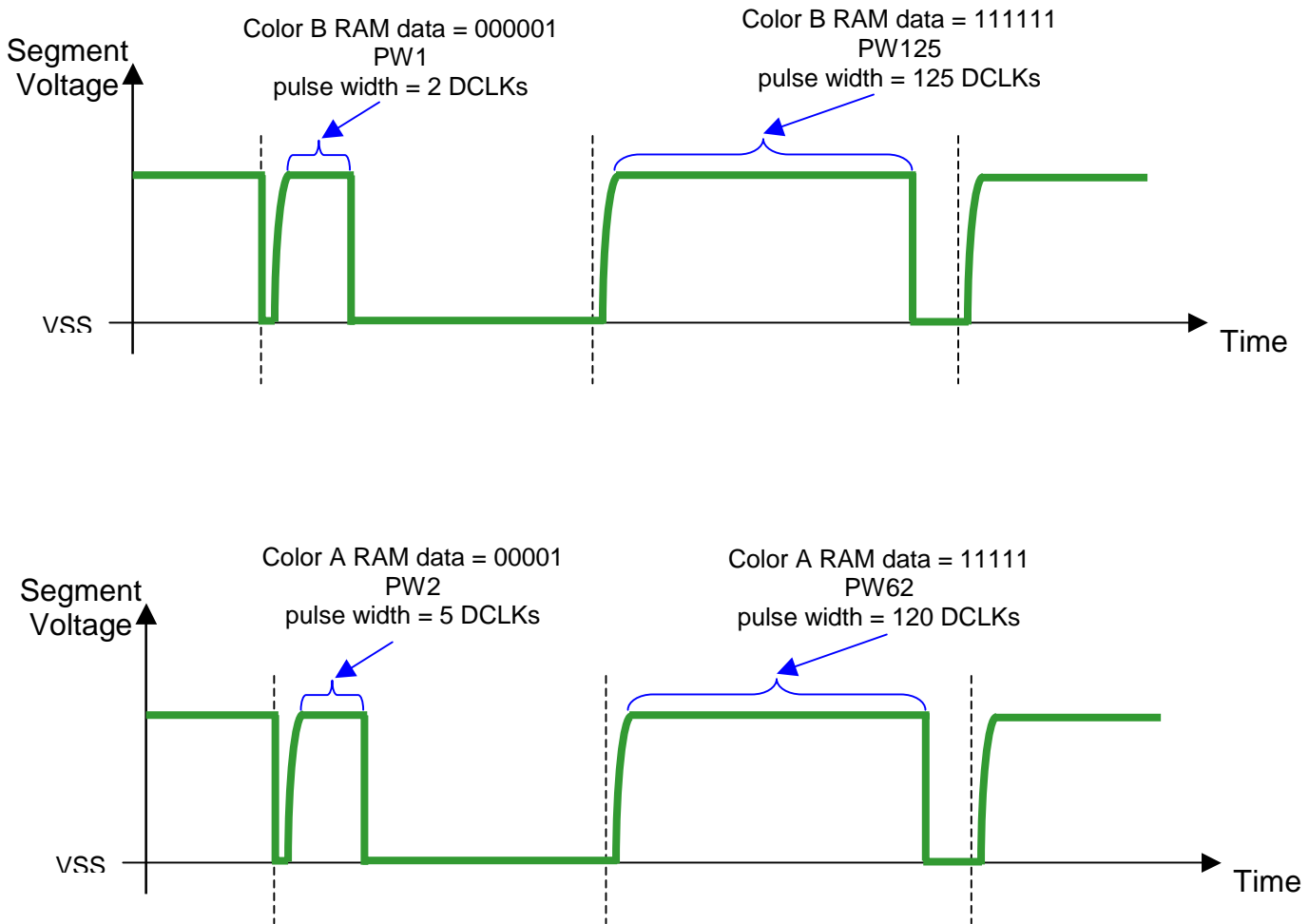

Figure 14 – illustration of relation between graphic display RAM value and gray scale control

DC-DC Voltage Converter

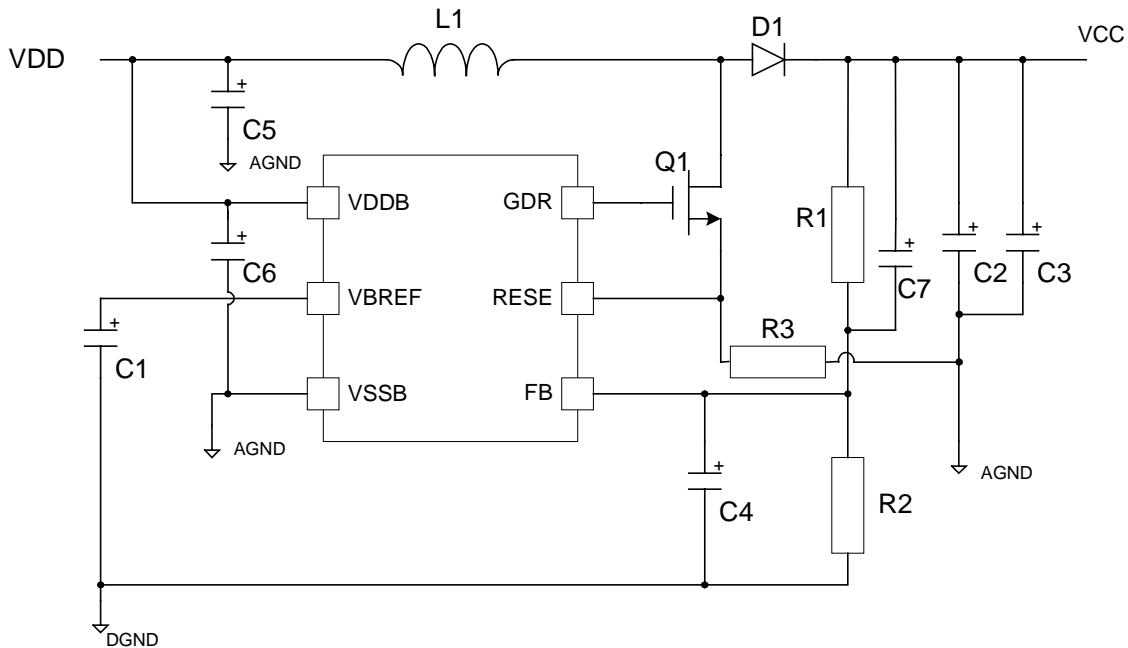

Figure 15 – DC-DC Converter Application Circuit Diagram

It is a switching voltage generator circuit, designed for handheld applications. In SSD1332, internal DC-DC voltage converter accompanying with an external application circuit (shown in Figure 15) can generate a high voltage supply V_{CC} from a low voltage supply input V_{DD} . V_{CC} is the voltage supply to the OLED driver block. The application circuit above is an example for the input voltage of 3V V_{DD} to generate V_{CC} of 12V @20mA ~ 30mA application.

*ALL PATHS TO AGND SHOULD BE CONNECTED AS SHORT AS POSSIBLE

Passive components selection:

Table 4 – Components Selection for DC-DC Converter

Components	Typical Value	Remark
L1	Inductor, 22 μ H	2A
D1	Schottky diode	2A, 25V e.g. 1N5822
Q1	MOSFET	N-FET with low $R_{DS(on)}$ and low V_{th} voltage. e.g. MGSF1N02LT1 [ON SEMICONDUCTOR]
R1, R2	Resistor	1%, 1/10W
R3	Resistor, 1.2 Ω	1%, 1/2W
C1	Capacitor, 1 μ F	16V
C2	Capacitor, 22 μ F	Low ESR, 25V
C3	Capacitor, 1 μ F	16V
C4	Capacitor, 10nF	16V
C5	Capacitor, 1 ~ 10 μ F	16V
C6	Capacitor, 0.1 ~ 1 μ F	16V
C7	Capacitor, 15nF	16V

The VCC output voltage level can be adjusted by R1 and R2, the reference formula is:

$$V_{CC} = 1.2 \times (R1+R2) / R2$$

8 COMMAND TABLE

Table 5 – Configuration Command Table

(To write commands to command registers, the MCU interface pins are set as: D/C = 0, R/W(WR#) = 0, E (RD#)=1)

D/C	Hex	D7	D6	D5	D4	D3	D2	D1	D0	Command	Description
0 0 0	15 A[6:0] B[6:0]	0 * *	0 A ₆ B ₆	0 A ₅ B ₅	1 A ₄ B ₄	0 A ₃ B ₃	1 A ₂ B ₂	0 A ₁ B ₁	1 A ₀ B ₀	Set Column Address	A[6:0] sets the column start address from 0-95, POR=00d. B[6:0] sets the column end address from 0-95 POR=95d.
0 0 0	75 A[5:0] B[5:0]	0 * *	1 * *	1 A ₅ B ₅	1 A ₄ B ₄	0 A ₃ B ₃	1 A ₂ B ₂	0 A ₁ B ₁	1 A ₀ B ₀	Set Row Address	A[5:0] sets the row start address from 0-63, POR=00d. B[5:0] sets the row end address from 0-63, POR=63d.
0 0	81 A[7:0]	1 A ₇	0 A ₆	0 A ₅	0 A ₄	0 A ₃	0 A ₂	0 A ₁	1 A ₀	Set Contrast for Color A (Segment Pins :SA0 – SA95)	Double byte command to select 1 out of 256 contrast steps. Contrast increases as level increases. POR = 80H
0 0	82 A[7:0]	1 A ₇	0 A ₆	0 A ₅	0 A ₄	0 A ₃	0 A ₂	1 A ₁	0 A ₀	Set Contrast for Color B (Segment Pins :SB0 – SB95)	Double byte command to select 1 out of 256 contrast steps. Contrast increases as level increases. POR = 80H
0 0	83 A[7:0]	1 A ₇	0 A ₆	0 A ₅	0 A ₄	0 A ₃	0 A ₂	1 A ₁	1 A ₀	Set Contrast for Color C (Segment Pins :SC0 – SC95)	Double byte command to select 1 out of 256 contrast steps. Contrast increases as level increases. POR = 80H
0 0	87 A[3:0]	1 *	0 *	0 *	0 *	0 A ₃	1 A ₂	1 A ₁	1 A ₀	Master Current Control	Set A[3:0] from 0000, 0001... to 1111 to adjust the master current attenuation factor from 1/16, 2/16... to 16/16. POR =1111b, for no attenuation.

0 0	A0 A[7:0]	1 A ₇	0 A ₆	1 A ₅	0 A ₄	0 *	0 *	0 A ₁	0 A ₀	Set Re-map & Data Format	<p>A[0]=0, Horizontal address increment (POR) A[0]=1, Vertical address increment</p> <p>A[1]=0, Column address 0 is mapped to SEG0 (POR) A[1]=1, Column address 95 is mapped to SEG0</p> <p>A[4]=0, Scan from COM 0 to COM [N-1] A[4]=1, Scan from COM [N-1] to COM0. Where N is the Multiplex ratio.</p> <p>A[5]=0, Disable COM Split Odd Even (POR) A[5]=1, Enable COM Split Odd Even</p> <p>A[7:6]=00; 256 color format = 01; 65k color format(POR)</p>
0 0	A1 A[5:0]	1 *	0 *	1 A ₅	0 A ₄	0 A ₃	0 A ₂	0 A ₁	1 A ₀	Set Display Start Line	<p>Set display RAM display start line register from 0-63. Display start line register is reset to 00H after POR.</p>
0 0	A2 A[5:0]	1 *	0 *	1 A ₅	0 A ₄	0 A ₃	0 A ₂	1 A ₁	0 A ₀	Set Display Offset	<p>Set vertical scroll by COM from 0-63. The value is reset to 00H after POR.</p>
0	A4~A7	1	0	1	0	0	1	X ₁	X ₀	Set Display Mode	<p>A4h=Normal Display (POR) A5h=Entire Display On, all pixels turn on at GS level 63 A6h=Entire Display Off, all pixels turn off A7h=Inverse Display</p>
0 0	A8 A[5:0]	1 *	0 *	1 A ₅	0 A ₄	1 A ₃	0 A ₂	0 A ₁	0 A ₀	Set Multiplex Ratio	<p>The next command determines multiplex ratio N from 16MUX-64MUX, POR=63d (64MUX) A[5:0]=0-14d (invalid entry)</p>
0 0	AD A[7:0]	1 1	0 0	1 0	0 0	1 1	1 A ₂	0 A ₁	1 A ₀	Set Master Configuration	<p>A[0]=0, Select external VCC supply at Display ON A[0]=1, Select internal booster at Display ON (POR)</p> <p>A[1]=0, Select external VCOMH voltage supply at Display ON A[1]=1, Select internal VCOMH regulator at Display ON (POR)</p> <p>A[2]=0, Select External VP voltage supply A[2]=1, Select Internal VP (POR)</p>
0	AE~AF	1	0	1	0	X ₃	1	1	1	Set Display On/Off	<p>A Eh=Display off (POR) A Fh=Display on</p>
0 0	B0 A[7:0]	1 0	0 0	1 0	1 A ₄	0 0	0 0	0 A ₁	0 0	Set Power Save	<p>A[7:0]=00 (POR) A[7:0]=12, power saving mode</p>
0 0	B1 A[7:0]	1 A ₇	0 A ₆	1 A ₅	1 A ₄	0 A ₃	0 A ₂	0 A ₁	1 A ₀	Phase 1 and 2 period adjustment	<p>A[3:0] Phase 1 period in 1~16 DCLK clocks [POR=4h] A[7:4] Phase 2 period in 1~16 DCLK clocks [POR=7h]</p>

0	B3	1	0	1	1	0	0	1	1	Display Clock Divider / Oscillator Frequency	A[3:0] [DIVIDER, POR=0] DCLK is generated from CLK divided by DIVIDER +1 (i.e., 1 to 16) A[7:4] Fosc frequency, POR=D0H Frequency increases as level increases		
0	A[7:0]	A ₇	A ₆	A ₅	A ₄	A ₃	A ₂	A ₁	A ₀				
0	B8	1	0	1	1	1	0	0	0	Set Gray Scale Table	The next 32 bytes of command set the current drive pulse width of gray scale level GS1, GS3, GS5 ...GS63 as below: A[7:0]=PW1, POR=1, it equals 1 DCLK clock B[7:0]=PW3, POR=5, it equals 3 DCLK clocks C[7:0]=PW5, POR= 9 : : : : AE[7:0]=PW61, POR=121 AF[7:0]=PW63, POR=125, it equals 125 DCLK clocks Note: GS0 has no pre-charge and current drive stages. For GS2 GS4...GS62, they are derived by driver itself with: PW _n = (PW _{n-1} +PW _{n+1})/2 Max pulse width is 125		
0	A[7:0]-- PW1	A ₇	A ₆	A ₅	A ₄	A ₃	A ₂	A ₁	A ₀				
0	B[7:0]-- PW3	B ₇	B ₆	B ₅	B ₄	B ₃	B ₂	B ₁	B ₀				
0	C[7:0]-- PW5	C ₇	C ₆	C ₅	C ₄	C ₃	C ₂	C ₁	C ₀				
0	:	:	:	:	:	:	:	:	:				
0	:	:	:	:	:	:	:	:	:				
0	:	:	:	:	:	:	:	:	:				
0	AE[7:0]-- PW61	AE ₇	AE ₆	AE ₅	AE ₄	AE ₃	AE ₂	AE ₁	AE ₀				
0	AF[7:0]-- PW63	AF ₇	AF ₆	AF ₅	AF ₄	AF ₃	AF ₂	AF ₁	AF ₀				
0	B9	1	0	1	1	1	0	0	1			Enable Linear Gray Scale Table	Enable build-in linear gray scale table (POR=Enable) PW1=1,PW2=3,PW3=5 ... PW61=121,PW62=123,PW63=125
0	BB ~ BD	1	0	1	1	1	X ₂	X ₁	X ₀			V _{PA} , V _{PB} , V _{PC} level setting for Color A,B,C	011b for Color A, 100b for Color B, 101b for Color C A[7:0] 00000000 0.43*Vref 00111111 0.83*Vref 01111111 1.0*Vref 1xxxxxxx connects to VCOMH (POR)
0	A[7:0]	A ₇	A ₆	A ₅	A ₄	A ₃	A ₂	A ₁	A ₀				
0	BE	1	0	1	1	1	1	1	0	Set VCOMH	A[6:0] 00000000 0.43*Vref 01111111 0.83*Vref (POR)		
0	A[6:0]	*	A ₆	A ₅	A ₄	A ₃	A ₂	A ₁	A ₀				
0	E3	1	1	1	0	0	0	1	1	NOP	Command for No Operation		

Table 6 – Graphic Acceleration Command Set Table

(To write commands to command registers, the MCU interface pins are set as: D/C = 0, R/W(WR#)=0, E (RD#)=1)

D/C	Hex	D7	D6	D5	D4	D3	D2	D1	D0	Command	Description
0	21	0	0	1	0	0	0	0	1	Draw Line	A[6:0] : Column Address of Start B[5:0] : Row Address of Start C[6:0] : Column Address of End D[5:0] : Row Address of End E[5:1] : Color C of the line F[5:0] : Color B of the line G[5:1] : Color A of the line
0	A[6:0]	*	A ₆	A ₅	A ₄	A ₃	A ₂	A ₁	A ₀		
0	B[5:0]	*	*	B ₅	B ₄	B ₃	B ₂	B ₁	B ₀		
0	C[6:0]	*	C ₆	C ₅	C ₄	C ₃	C ₂	C ₁	C ₀		
0	D[5:0]	*	*	D ₅	D ₄	D ₃	D ₂	D ₁	D ₀		
0	E[5:1]	*	*	E ₅	E ₄	E ₃	E ₂	E ₁	*		
0	F[5:0]	*	*	F ₅	F ₄	F ₃	F ₂	F ₁	F ₀		
0	G[5:1]	*	*	G ₅	G ₄	G ₃	G ₂	G ₁	*		
0	22	0	0	1	0	0	0	1	0		Drawing Rectangle
0	A[6:0]	*	A ₆	A ₅	A ₄	A ₃	A ₂	A ₁	A ₀		
0	B[5:0]	*	*	B ₅	B ₄	B ₃	B ₂	B ₁	B ₀		
0	C[6:0]	*	C ₆	C ₅	C ₄	C ₃	C ₂	C ₁	C ₀		
0	D[5:0]	*	*	D ₅	D ₄	D ₃	D ₂	D ₁	D ₀		
0	E[5:1]	*	*	E ₅	E ₄	E ₃	E ₂	E ₁	*		
0	F[5:0]	*	*	F ₅	F ₄	F ₃	F ₂	F ₁	F ₀		
0	G[5:1]	*	*	G ₅	G ₄	G ₃	G ₂	G ₁	*		
0	H[5:1]	*	*	H ₅	H ₄	H ₃	H ₂	H ₁	*		
0	I[5:0]	*	*	I ₅	I ₄	I ₃	I ₂	I ₁	I ₀		
0	J[5:1]	*	*	J ₅	J ₄	J ₃	J ₂	J ₁	*		
0	23	0	0	1	0	0	0	1	1	Copy	A[6:0] : Column Address of Start B[5:0] : Row Address of Start C[6:0] : Column Address of End D[5:0] : Row Address of End E[6:0] : Column Address of New Start F[5:0] : Row Address of New Start
0	A[6:0]	*	A ₆	A ₅	A ₄	A ₃	A ₂	A ₁	A ₀		
0	B[5:0]	*	*	B ₅	B ₄	B ₃	B ₂	B ₁	B ₀		
0	C[6:0]	*	C ₆	C ₅	C ₄	C ₃	C ₂	C ₁	C ₀		
0	D[5:0]	*	*	D ₅	D ₄	D ₃	D ₂	D ₁	D ₀		
0	E[6:0]	*	E ₆	E ₅	E ₄	E ₃	E ₂	E ₁	E ₀		
0	F[5:0]	*	*	F ₅	F ₄	F ₃	F ₂	F ₁	F ₀		
0	24	0	0	1	0	0	1	0	0	Dim Window	A[6:0] : Column Address of Start B[5:0] : Row Address of Start C[6:0] : Column Address of End D[5:0] : Row Address of End The effect of dim window: GS15~GS0 no change GS19~GS16 become GS4 GS23~GS20 become GS5 ... GS63~GS60 become GS15
0	A[6:0]	*	A ₆	A ₅	A ₄	A ₃	A ₂	A ₁	A ₀		
0	B[5:0]	*	*	B ₅	B ₄	B ₃	B ₂	B ₁	B ₀		
0	C[6:0]	*	C ₆	C ₅	C ₄	C ₃	C ₂	C ₁	C ₀		
0	D[5:0]	*	*	D ₅	D ₄	D ₃	D ₂	D ₁	D ₀		
0	25	0	0	1	0	0	1	0	1	Clear Window	A[6:0] : Column Address of Start B[5:0] : Row Address of Start C[6:0] : Column Address of End D[5:0] : Row Address of End
0	A[6:0]	*	A ₆	A ₅	A ₄	A ₃	A ₂	A ₁	A ₀		
0	B[5:0]	*	*	B ₅	B ₄	B ₃	B ₂	B ₁	B ₀		
0	D[5:0]	*	*	D ₅	D ₄	D ₃	D ₂	D ₁	D ₀		

D/C	Hex	D7	D6	D5	D4	D3	D2	D1	D0	Command	Description
0	26	0	0	1	0	0	1	1	0	Fill Enable / Disable	A0 0 : Disable Fill for Draw Rectangle Command (POR) 1 : Enable Fill for Draw Rectangle Command
0	A[4:0]	*	*	*	A ₄	0	0	0	A ₀		A[3:1] 000 : Reserved values A4 0 : Disable reverse copy (POR) 1 : Enable reverse during copy command.

Table 7 - Read Command Table

(D/C=0, R/W (WR#)=1, E (RD#)=1 for 6800 or E (RD#)=0 for 8080)

Bit Pattern	Command	Description
D ₇ D ₆ D ₅ D ₄ D ₃ D ₂ D ₁ D ₀	Status Register Read *	D ₇ : "1" for Command lock D ₆ : "1" for display OFF / "0" for display ON D ₅ : Reserve D ₄ : Reserve D ₃ : Reserve D ₂ : Reserve D ₁ : Reserve D ₀ : Reserve

Note: Patterns other than that given in Command Table are prohibited to enter to the chip as a command; otherwise, unexpected result will occur.

Data Read / Write

To read data from the GDDRAM, input HIGH to R/W (WR#) pin and D/C pin for 6800-series parallel mode, LOW to E (RD#) pin and HIGH to D/C pin for 8080-series parallel mode. No data read is provided in serial mode operation.

In normal data read mode, GDDRAM column address pointer will be increased by one automatically after each data read.

Also, a dummy read is required before the first data read. See Figure 5 in Functional Block Description.

To write data to the GDDRAM, input LOW to R/W (WR#) pin and HIGH to D/C pin for 6800-series parallel mode AND 8080-series parallel mode. For serial interface mode, it is always in write mode. GDDRAM column address pointer will be increased by one automatically after each data write.

Table 8 - Address increment table (Automatic)

D/C	R/W (WR#)	Comment	Address Increment
0	0	Write Command	No
0	1	Read Status	No
1	0	Write Data	Yes
1	1	Read Data	Yes

9 COMMAND DESCRIPTIONS

Set Column Address (15h)

This command specifies column start address and end address of the display data RAM. This command also sets the column address pointer to column start address. This pointer is used to define the current read/write column address in graphic display data RAM. If horizontal address increment mode is enabled by command A0h, after finishing read/write one column data, it is incremented automatically to the next column address. Whenever the column address pointer finishes accessing the end column address, it is reset back to start column address.

Set Row Address (75h)

This command specifies row start address and end address of the display data RAM. This command also sets the row address pointer to row start address. This pointer is used to define the current read/write row address in graphic display data RAM. If vertical address increment mode is enabled by command A0h, after finishing read/write one row data, it is incremented automatically to the next row address. Whenever the row address pointer finishes accessing the end row address, it is reset back to start row address.

For example, column start address is set to 2 and column end address is set to 93, row start address is set to 1 and row end address is set to 62. Horizontal address increment mode is enabled by command A0h. In this case, the graphic display data RAM column accessible range is from column 2 to column 93 and from row 1 to row 62 only. In addition, the column address pointer is set to 2 and row address pointer is set to 1. After finishing read/write one pixel of data, the column address is increased automatically by 1 to access the next RAM location for next read/write operation. Whenever the column address pointer finishes accessing the end column 93, it is reset back to column 2 and row address is automatically increased by 1. While the end row 62 and end column 93 RAM location is accessed, the row address is reset back to 1. The diagram below shows the way of column and row address pointer movement for this example.

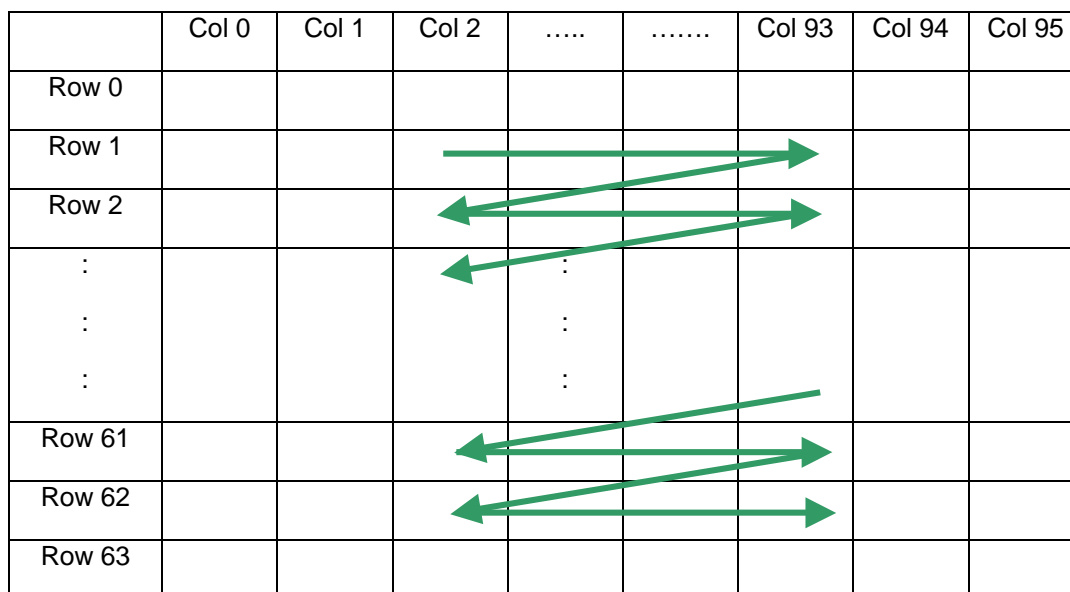

Figure 16 – Example of Column and Row Address Pointer Movement

Set Contrast for Color A, B, C (81h, 82h, 83h)

This command is to set Contrast Setting of each color A, B and C. The chip has three contrast control circuits for color A, B and C. Each contrast circuit has 256 contrast steps from 00h to FFh. The segment output current I_{SEG} increases linearly with the contrast step, which results in brighter of the color. This relation is shown in Figure 17. In many situations, the output brightness of color A, B and C pixels are different under the same segment current condition. The contrasts of color A, B and C are set such that the brightness of each color are the same on the OLED panel

Master Current Control (87h)

This command is to control the segment output current by a scale factor. This factor is common to color A, B and C. The chip has 16 master control steps. The factor is ranged from 1 [0000] to 16 [1111]. POR is 16 [1111]. The smaller the master current value, the dimmer the OLED panel display is set. For example, if original segment output current of a color is 160uA at scale factor = 16, setting scale factor to 8 to reduce the current to 80uA. Please see Figure 17.

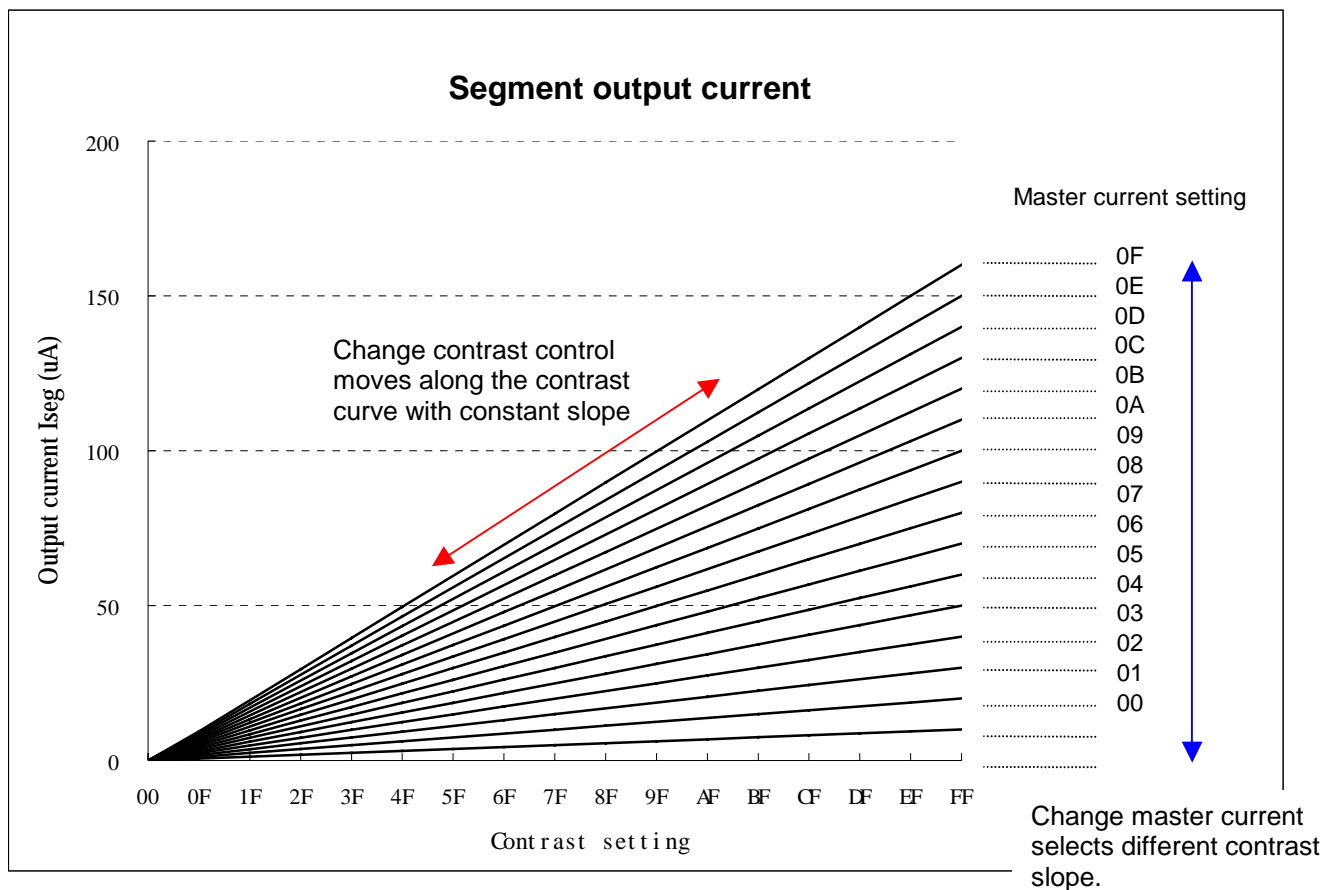

Figure 17 – Segment Output Current for Different Contrast Control and Master Current Setting

Set Re-map & Data Format (A0h)

This command has multiple configurations and each bit setting is described as follows.

- Address increment mode (A[0])

When it is set to 0, the driver is set as horizontal address increment mode. After the display RAM is read/written, the column address pointer is increased automatically by 1. If the column address pointer reaches column end address, the column address pointer is reset to column start address and row address pointer is increased by 1. The sequence of movement of the row and column address point for horizontal address increment mode is shown in Figure 18.

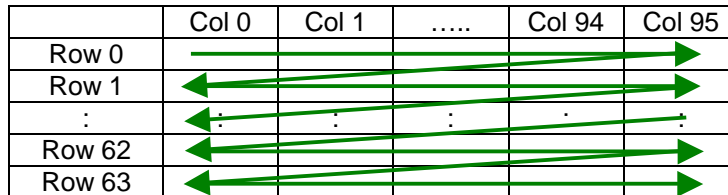

Figure 18 – Address Pointer Movement of Horizontal Address Increment Mode

When A[0] is set to 1, the driver is set to vertical address increment mode. After the display RAM is read/written, the row address pointer is increased automatically by 1. If the row address pointer reaches the row end address, the row address pointer is reset to row start address and column address pointer is increased by 1. The sequence of movement of the row and column address point for vertical address increment mode is shown in Figure 19.

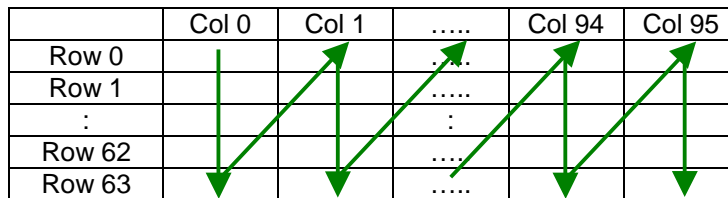

Figure 19 – Address Pointer Movement of Vertical Address Increment Mode

- Column Address Mapping (A[1])
This command bit is made for flexible layout of segment signals in OLED module with segment arranged from left to right or vice versa.
- COM Remap (A[4])
This bit determines the scanning direction of the common for flexible layout of common signals in OLED module either from up to down or vice versa.
- Odd even split of COM pins (A[5])
This bit can set the odd even arrangement of COM pins.
A[5] = 0: Disable COM split odd even, pin assignment of common is in sequential as
COM63 COM62 COM 33 COM32..SC95..SA0..COM0 COM1.... COM30 COM31
A[5] = 1: Enable COM split odd even, pin assignment of common is in odd even split as
COM63 COM61.... COM3 COM1..SC95..SA0..COM0 COM2.... COM60 COM62
- Display color mode (A[7:6])
Select either 65k or 256 color mode. The display RAM data format in different mode is described in section “Graphic Display Data RAM (GDDRAM)”.

Set Display Start Line (A1h)

This command is to set Display Start Line register to determine starting address of display RAM to be displayed by selecting a value from 0 to 63. The figure below shows an example of this command. In there, "Row" means the graphic display data RAM row.

	64	64	62	62	Mux ratio
COM Pin	0	4	0	4	Display start line
COM0	Row0	Row4	Row0	Row4	
COM1	Row1	Row5	Row1	Row5	
COM2	Row2	Row6	Row2	Row6	
COM3	Row3	Row7	Row3	Row7	
:	:	:	:	:	
:	:	:	:	:	
COM57	Row57	Row61	Row57	Row61	
COM58	Row58	Row62	Row58	Row62	
COM59	Row59	Row63	Row59	Row63	
COM60	Row60	Row0	Row60	Row0	
COM61	Row61	Row1	Row61	Row1	
COM62	Row62	Row2	-	-	
COM63	Row63	Row3	-	-	

Figure 20 – Example of Set Display Start Line with no Remap

Set Display Offset (A2h)

This command specifies the mapping of display start line (it is assumed that COM0 is the display start line, display start line register equals to 0) to one of COM0-63. For example, to move the COM16 towards the COM0 direction for 16 lines, the 6-bit data in the second command should be given by 0010000. The figure below shows an example of this command. In there, "Row" means the graphic display data RAM row.

	64	64	62	62	Mux ratio
COM Pin	0	4	0	4	Display offset
COM0	Row0	Row4	Row0	Row4	
COM1	Row1	Row5	Row1	Row5	
COM2	Row2	Row6	Row2	Row6	
COM3	Row3	Row7	Row3	Row7	
:	:	:	:	:	
:	:	:	:	:	
COM57	Row57	Row61	Row57	Row61	
COM58	Row58	Row62	Row58	-	
COM59	Row59	Row63	Row59	-	
COM60	Row60	Row0	Row60	Row0	
COM61	Row61	Row1	Row61	Row1	
COM62	Row62	Row2	-	Row2	
COM63	Row63	Row3	-	Row3	

Figure 21 – Example of Set Display Offset with no Remap

Set Display Mode (A4h ~ A7h)

These are single byte command and they are used to set Normal Display, Entire Display On, Entire Display Off and Inverse Display.

- Set Entire Display On (A5h)
Forces the entire display to be at "GS63" regardless of the contents of the display data RAM.
- Set Entire Display Off (A6h)
Forces the entire display to be at gray level "GS0" regardless of the contents of the display data RAM.
- Inverse Display (A7h)
The gray level of display data are swapped such that "GS0" <-> "GS63", "GS1" <-> "GS62",
- Normal Display (A4h)
Reset the above effect and turn the data to ON at the corresponding gray level.

Set Multiplex Ratio (A8h)

This command switches default 1:64 multiplex mode to any multiplex mode from 16 to 64. For example, when multiplex ratio is set to 16, only 16 common pins are enabled. The starting and the ending of the enabled common pins are depended on the setting of "Display Offset" register programmed by command A2h.

Set Master Configuration (ADh)

This command contains multiple bits to control several functionalities of the driver.

- Select DC-DC converter (A[0])
0 = Disable selection of DC-DC converter and VCC is supplied externally.
1 (POR) = Enable selection of DC-DC converter to supply high voltage to VCC. The output voltage of the converter is set by values of external resistors. Please refer to section "DC-DC Voltage Converter" for details.
- Select V_{COMH} supply (A[1])
0 = Select external V_{COMH} voltage from V_{COMH} pin for the common waveform high voltage level supply. It is recommended to set the voltage of V_{COMH} such that the OLED pixel diode is not turned on (prefer in reverse bias state) when the segment pin is either driven to V_{PA} , V_{PB} or V_{PC} level.
1 = Select internal V_{COMH} voltage generated by regulator from V_{REF} . The level of V_{COMH} can be programmed by command BEh.
- Select pre-charge voltage supply (A[2])
0 = Select pre-charge voltage sources from external pins V_{PA} , V_{PB} , V_{PC} for color A, B and C respectively.
1 = Select pre-charge voltage supply internally. The level of V_{PA} , V_{PB} , V_{PC} can be set by command BBh, BCh and BDh for color A, B and C respectively.

Set Display On/Off (AEh/AFh)

These single byte commands are used to turn the OLED panel display on or off. When the display is on, the selected circuits by Set Master Configuration command will be turned on. When the display is off, those circuits will be turned off and the segment and common output are in high impedance state.

Phase 1 and 2 Period Adjustment (B1h)

This command sets the length of phase 1 and 2 of segment waveform of the driver.

- Phase 1 (A[3:0]): Set the period from 1 to 16 in the unit of DCLKs. A larger capacitance of the OLED pixel may require longer period to discharge the previous data charge completely.
- Phase 2 (A[7:4]): Set the period from 1 to 16 in the unit of DCLKs. A longer period is needed to charge up a larger capacitance of the OLED pixel to the target voltage V_{PA} , V_{PB} , V_{PC} for color A, B and C respectively.

Set Display Clock Divide Ratio/ Oscillator Frequency (B3h)

This command consists of two functions:

- Display Clock Divide Ratio (A[3:0])
Set the divide ratio to generate DCLK (Display Clock) from CLK. The divide ratio is from 1 to 16, with power on reset value = 1. Please refer to section "Oscillator Circuit and Display Time Generator" for the details of DCLK and CLK.
- Oscillator Frequency (A[7:4])
Program the oscillator frequency Fosc which is the source of CLK if CLS pin is pulled high. The 4-bit value results in 16 different frequency setting available as shown below. The default value is 1101b which represents 0.97MHz Fosc.

Set Gray Scale Table (B8h)

This command is used to set the gray scale table for the display. Except gray scale entry 0, which is zero as it has no pre-charge and current drive, each odd entry gray scale level is programmed in the length of current drive stage pulse width with unit of DCLK. The longer the length of the pulse width, the brighter is the OLED pixel when it's turned on. Please refer to section "Graphic Display Data RAM (GDDRAM)" for more detailed explanation of relation of display data RAM, gray scale table and the pixel brightness.

Following the command B8h, the user has to set the pulse width from PW1, PW3, PW5, ..., PW59, PW61, PW63 one by one in sequence and complies the following conditions.

$$PW1 > 0; PW3 > PW1 + 1; PW5 > PW3 + 1; \dots$$

Afterwards, the driver automatically derives the pulse width of even entry of gray scale table PW2, PW4, ..., PW62 with the formula like below.

$$PWn = (PWn-1 + PWn+1) / 2$$

For example, if PW1 = 3 DCLKs and PW3 = 7 DCLKs, PW2 = (3+7)/2 = 5 DCLKs

The setting of gray scale table entry can perform gamma correction on OLED panel display. Normally, it is desired that the brightness response of the panel is linearly proportional to the image data value in display data RAM. However, the OLED panel is somehow responded in non-linear way. Appropriate gray scale table setting like example below can compensate this effect.

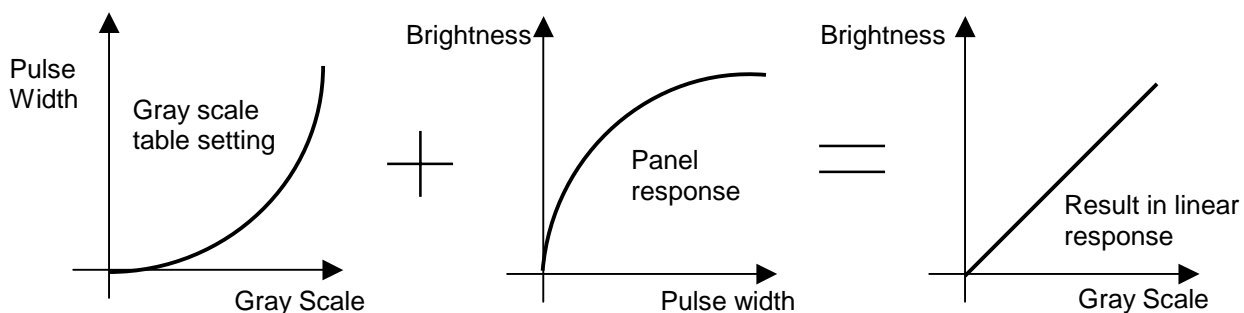

Figure 22 – Example of gamma correction by gray scale table setting

Enable Linear Gray Scale Table (B9h)

This command reloads the preset linear gray scale table as PW1 = 1, PW2 = 3, PW3 = 5, ..., PW62 = 123, PW63 = 125 DCLKs.

Set V_{PA} , V_{PB} and V_{PC} Voltage for Color A, B and C (BBh, BCh and BDh)

These three commands are used to set V_{PA} , V_{PB} and V_{PC} phase 2 voltage level for color A, B and C respectively. The commands are valid in condition that these voltages are selected to generate internally by command ADh. It can be programmed to set the pre-charge voltage reference to V_{REF} or V_{COMH} .

Set V_{COMH} Voltage (BEh)

This command sets the high voltage level of common pins, V_{COMH} , when it is selected to generate internally by command ADh. The level of V_{COMH} is programmed with reference to V_{REF} .

10 GRAPHIC ACCELERATION COMMAND SET DESCRIPTION

Draw Line (21h)

This command draws a line by the given start, end column and row coordinates and the color of the line.

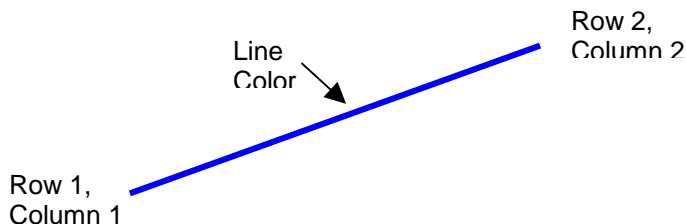

Figure 23 – Example of Draw Line Command

For example, the line above can be drawn by the following command sequence.

1. Enter into draw line mode by command 21h
2. Send column start address of line, column1, for example = 1h
3. Send row start address of line, row 1, for example = 10h
4. Send column end address of line, column 2, for example = 28h
5. Send row end address of line, row 2, for example = 4h
6. Send color C, B and A of line, for example = 35d, 0d, 0d for blue color

Draw Rectangle (22h)

Given the starting point (Row 1, Column 1) and the ending point (Row 2, Column 2), specify the outline and fill area colors, a rectangle that will be drawn with the color specified. Remarks: If fill color option is disabled, the enclosed area will not be filled.

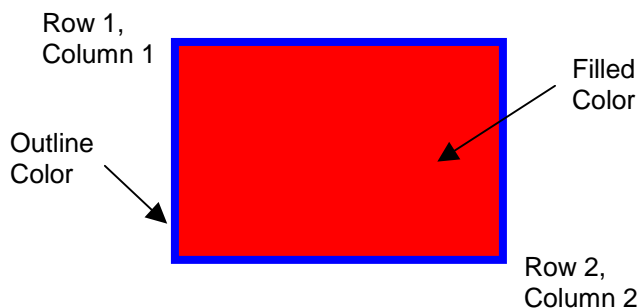

Figure 24 – Example of Draw Rectangle Command

The following example illustrates the rectangle drawing command sequence.

1. Enter the "draw rectangle mode" by execute the command 22h
2. Set the starting column coordinates, Column 1. e.g., 03h.
3. Set the starting row coordinates, Row 1. e.g., 02h.
4. Set the finishing column coordinates, Column 2. e.g., 12h
5. Set the finishing row coordinates, Row 2. e.g., 15h
6. Set the outline color C, B and A. e.g., (28d, 0d, 0d) for blue color
7. Set the filled color C, B and A. e.g., (0d, 0d, 40d) for red color

Copy (23h)

Copy the rectangular region defined by the starting point (Row 1, Column 1) and the ending point (Row 2, Column 2) to location (Row 3, Column 3). If the new coordinates are smaller than the ending points, the new image will overlap the original one.

The following example illustrates the copy procedure.

1. Enter the "copy mode" by execute the command 23h
2. Set the starting column coordinates, Column 1. E.g., 00h.
3. Set the starting row coordinates, Row 1. E.g., 00h.
4. Set the finishing column coordinates, Column 2. E.g., 05h
5. Set the finishing row coordinates, Row 2. E.g., 05h
6. Set the new column coordinates, Column 3. E.g., 03h
7. Set the new row coordinates, Row 3. E.g., 03h

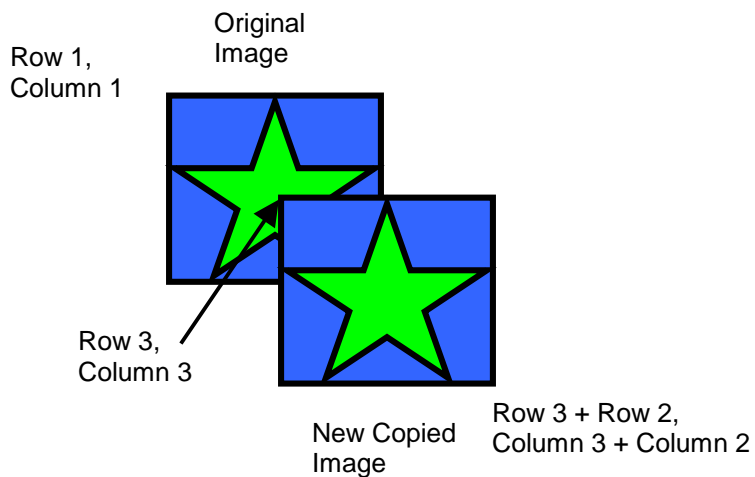

Figure 25 – Example of Copy Command

Dim Window (24h)

This command will dim the window area specify by starting point (Row 1, Column 1) and the ending point (Row 2, Column 2). After the execution of this command, the selected window area will become darker as follow.

Table 9 – Result of Change of Brightness by Dim Window Command

Original gray scale	New gray scale after dim window command
GS0 ~ GS15	No change
GS16 ~ GS19	GS4
GS20 ~ GS23	GS5
:	:
GS60 ~ GS63	GS15

Additional execution of this command over the same window area will not change the data content.

Clear Window (25h)

This command sets the window area specify by starting point (Row 1, Column 1) and the ending point (Row 2, Column 2) to clear the window display. The graphic display data RAM content of the specified window area will be set to zero.

This command can be combined with Copy command to make as a “move” result. The following example illustrates the copy plus clear procedure and results in moving the window object.

1. Enter the “copy mode” by execute the command 23h
2. Set the starting column coordinates, Column 1. E.g., 00h.
3. Set the starting row coordinates, Row 1. E.g., 00h.
4. Set the finishing column coordinates, Column 2. E.g., 05h
5. Set the finishing row coordinates, Row 2. E.g., 05h
6. Set the new column coordinates, Column 3. E.g., 06h
7. Set the new row coordinates, Row 3. E.g., 06h
8. Enter the “clear mode” by execute the command 24h
9. Set the starting column coordinates, Column 1. E.g., 00h.
10. Set the starting row coordinates, Row 1. E.g., 00h.
11. Set the finishing column coordinates, Column 2. E.g., 05h
12. Set the finishing row coordinates, Row 2. E.g., 05h

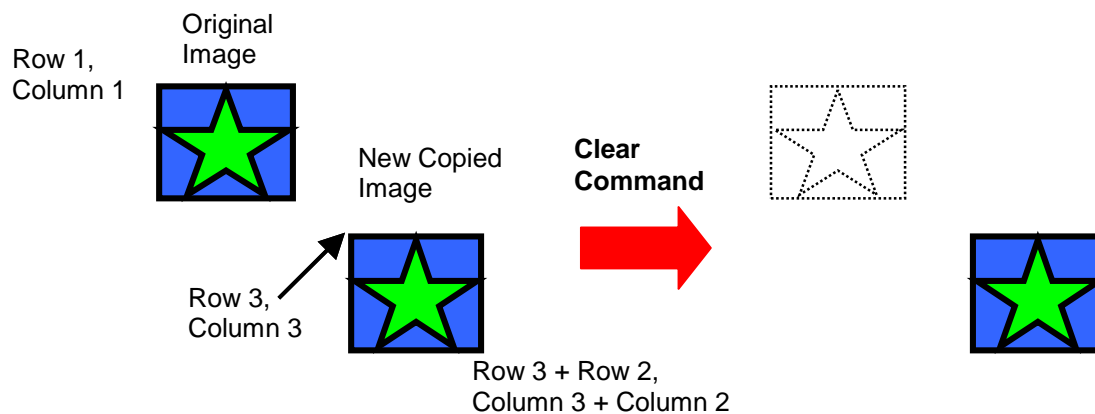

Figure 26 – Example of Copy + Clear = Move Command

Fill Enable/Disable (26h)

This command has two functions.

- Enable/Disable fill (A[0])
0 = Disable filling of color into rectangle in draw rectangle command. (POR)
1 = Enable filling of color into rectangle in draw rectangle command.
- Enable/Disable reverse copy (A[4])
0 = Disable reverse copy (POR)
1 = During copy command, the new image colors are swapped such that “GS0” <-> “GS63”, “GS1” <-> “GS62”,

11 MAXIMUM RATINGS

Table 10 - Maximum Ratings

(Voltage Reference to V_{SS})

Symbol	Parameter	Value	Unit
V_{DD}	Supply Voltage	-0.3 to +4	V
V_{CC}		0 to 18	V
V_{REF}		0 to 18	V
V_{COMH}	Supply Voltage/Output voltage	0 to 16	V
-	SEG/COM output voltage	0 to 16	V
V_{in}	Input voltage	$V_{SS}-0.3$ to $V_{DD}+0.3$	V
T_A	Operating Temperature	-40 to +85	°C
T_{stg}	Storage Temperature Range	-65 to +150	°C

*Maximum Ratings are those values beyond which damage to the device may occur. Functional operation should be restricted to the limits in the Electrical Characteristics tables or Pin Description.

12 DC CHARACTERISTICS

Table 11 - DC Characteristics

(Unless otherwise specified, Voltage Referenced to V_{SS} , $V_{DD} = 2.4$ to $3.5V$, $T_A = 25^\circ C$)

Symbol	Parameter	Test Condition	Min	Typ	Max	Unit
V_{CC}	Operating Voltage		7	11	18	V
V_{DD}	Logic Supply Voltage		2.4	2.7	3.5	V
V_{OH}	High Logic Output Level	$I_{out} = 100\mu A$, 3.3MHz	$0.9 \cdot V_{DD}$	-	V_{DD}	V
V_{OL}	Low Logic Output Level	$I_{out} = 100\mu A$, 3.3MHz	0	-	$0.1 \cdot V_{DD}$	V
V_{IH}	High Logic Input Level	$I_{out} = 100\mu A$, 3.3MHz	$0.8 \cdot V_{DD}$	-	V_{DD}	V
V_{IL}	Low Logic Input Level	$I_{out} = 100\mu A$, 3.3MHz	0	-	$0.2 \cdot V_{DD}$	V
I_{SLEEP}	Sleep mode Current	$V_{DD}=2.7V$, Display OFF, No panel attached	-	-	5	μA
I_{CC}	V_{CC} Supply Current	$V_{DD}=2.7V$, $V_{CC}=11V$, Display ON Contrast =FF, No panel attached	-	770	-	μA
I_{DD}	V_{DD} Supply Current	$V_{DD}=2.7V$, $V_{CC}=11V$, Display ON Contrast =FF, No panel attached	-	170	-	μA
I_{SEG}	Segment Output Current Setting $V_{DD}=2.7V$, $V_{CC}=11V$, $I_{REF}=10\mu A$, All one pattern, Display on, Segment pin under test is connected with a $33K\Omega$ resistive load to V_{CC} .	Contrast = FF	-	160	-	μA
		Contrast = AF	-	110	-	μA
		Contrast = 5F	-	60	-	μA
		Contrast = 00	-	0	-	μA
Dev	Segment output current uniformity	$Dev = (I_{SEG} - I_{MID})/I_{MID}$ $I_{MID} = (I_{MAX} + I_{MIN})/2$ $I_{SEG}[0:287] =$ Segment current at contrast = FF	-	-	3	%
Adj. Dev	Adjacent pin output current uniformity (contrast = FF)	$Adj\ Dev = (I[n]-I[n+1]) / (I[n]+I[n+1])$	-	± 2.0	--	%
V_{CC}	Booster output voltage (V_{CC})	$V_{in}=3V$, $L=22\mu H$; $R1=450K\Omega$; $R2=50K\Omega$; $I_{CC} = 30mA$ (soaking)	11	-	13	V
Pwr	Booster output power	$V_{in}=3V$, $L=22\mu H$; $V_{CC} = 10V \sim 16V$	-	-	400	mW

13 AC CHARACTERISTICS

Table 12 - AC Characteristics

(Unless otherwise specified, Voltage Referenced to V_{SS} , $V_{DD} = 2.4$ to $3.5V$, $T_A = 25^\circ C$.)

Symbol	Parameter	Test Condition	Min	Typ	Max	Unit
F_{OSC}	Oscillation Frequency of Display Timing Generator	$V_{DD} = 2.7V$	-	0.97	-	MHz
F_{FRM}	Frame Frequency for 64 MUX Mode	96RGB x 64 Graphic Display Mode, Display ON, Internal Oscillator Enabled	-	$F_{OSC} \times \frac{1}{(D \times K \times 64)}$	-	Hz

D: divide ratio (POR=1)

K: number of display clocks (POR=136, i.e. phase1 dclk+phase2 dclk+ phase3 dclk=4+7+125)

Table 13 - 6800-Series MPU Parallel Interface Timing Characteristics

($V_{DD} - V_{SS} = 2.4$ to $3.5V$, $T_A = -40$ to $85^{\circ}C$)

Symbol	Parameter	Min	Typ	Max	Unit
t_{cycle}	Clock Cycle Time	300	-	-	ns
t_{AS}	Address Setup Time	0	-	-	ns
t_{AH}	Address Hold Time	0	-	-	ns
t_{DSW}	Write Data Setup Time	40	-	-	ns
t_{DHW}	Write Data Hold Time	15	-	-	ns
t_{DHR}	Read Data Hold Time	20	-	-	ns
t_{OH}	Output Disable Time	-	-	70	ns
t_{ACC}	Access Time	-	-	140	ns
PW_{CSL}	Chip Select Low Pulse Width (read)	120	-	-	ns
	Chip Select Low Pulse Width (write)	60	-	-	ns
PW_{CSH}	Chip Select High Pulse Width (read)	60	-	-	ns
	Chip Select High Pulse Width (write)	60	-	-	ns
t_R	Rise Time	-	-	15	ns
t_F	Fall Time	-	-	15	ns

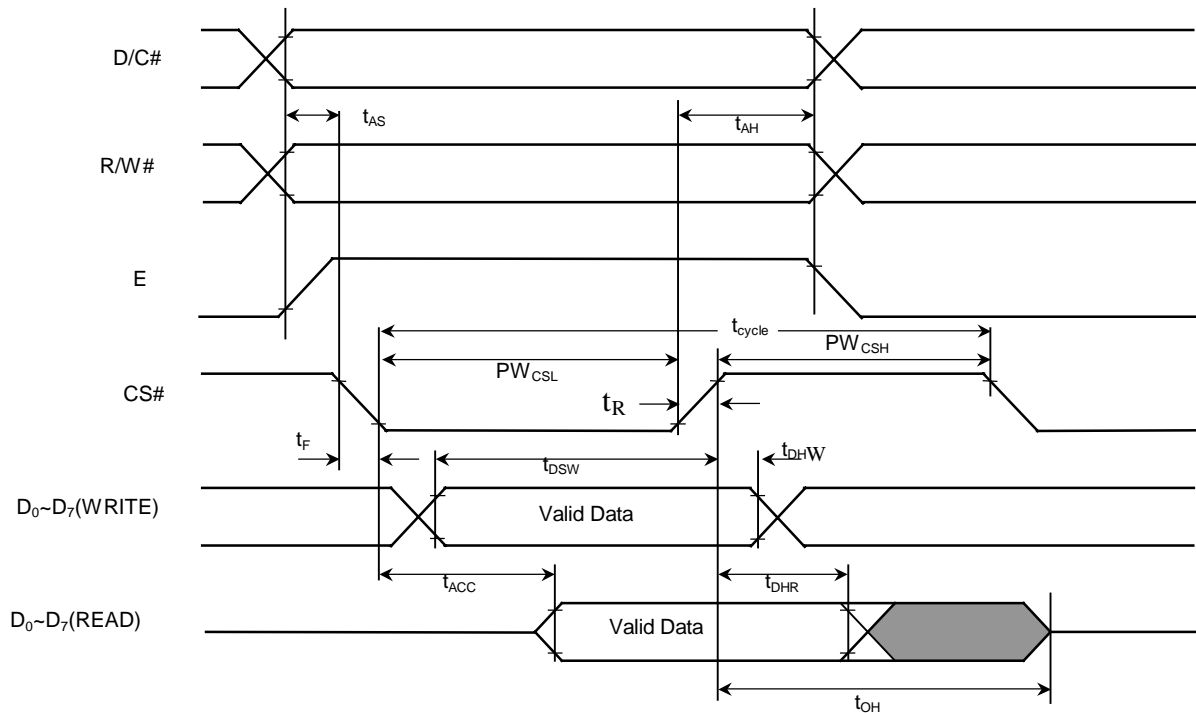

Figure 27 - 6800-series MPU parallel interface characteristics

Table 14 - 8080-Series MPU Parallel Interface Timing Characteristics

($V_{DD} - V_{SS} = 2.4$ to $3.5V$, $T_A = -40$ to $85^\circ C$)

Symbol	Parameter	Min	Typ	Max	Unit
t_{cycle}	Clock Cycle Time	300	-	-	ns
t_{AS}	Address Setup Time	0	-	-	ns
t_{AH}	Address Hold Time	0	-	-	ns
t_{DSW}	Write Data Setup Time	40	-	-	ns
t_{DHW}	Write Data Hold Time	15	-	-	ns
t_{DHR}	Read Data Hold Time	20	-	-	ns
t_{OH}	Output Disable Time	-	-	70	ns
t_{ACC}	Access Time	-	-	140	ns
PW_{CSL}	Chip Select Low Pulse Width (read)	120	-	-	ns
	Chip Select Low Pulse Width (write)	60	-	-	ns
PW_{CSH}	Chip Select High Pulse Width (read)	60	-	-	ns
	Chip Select High Pulse Width (write)	60	-	-	ns
t_R	Rise Time	-	-	15	ns
t_F	Fall Time	-	-	15	ns

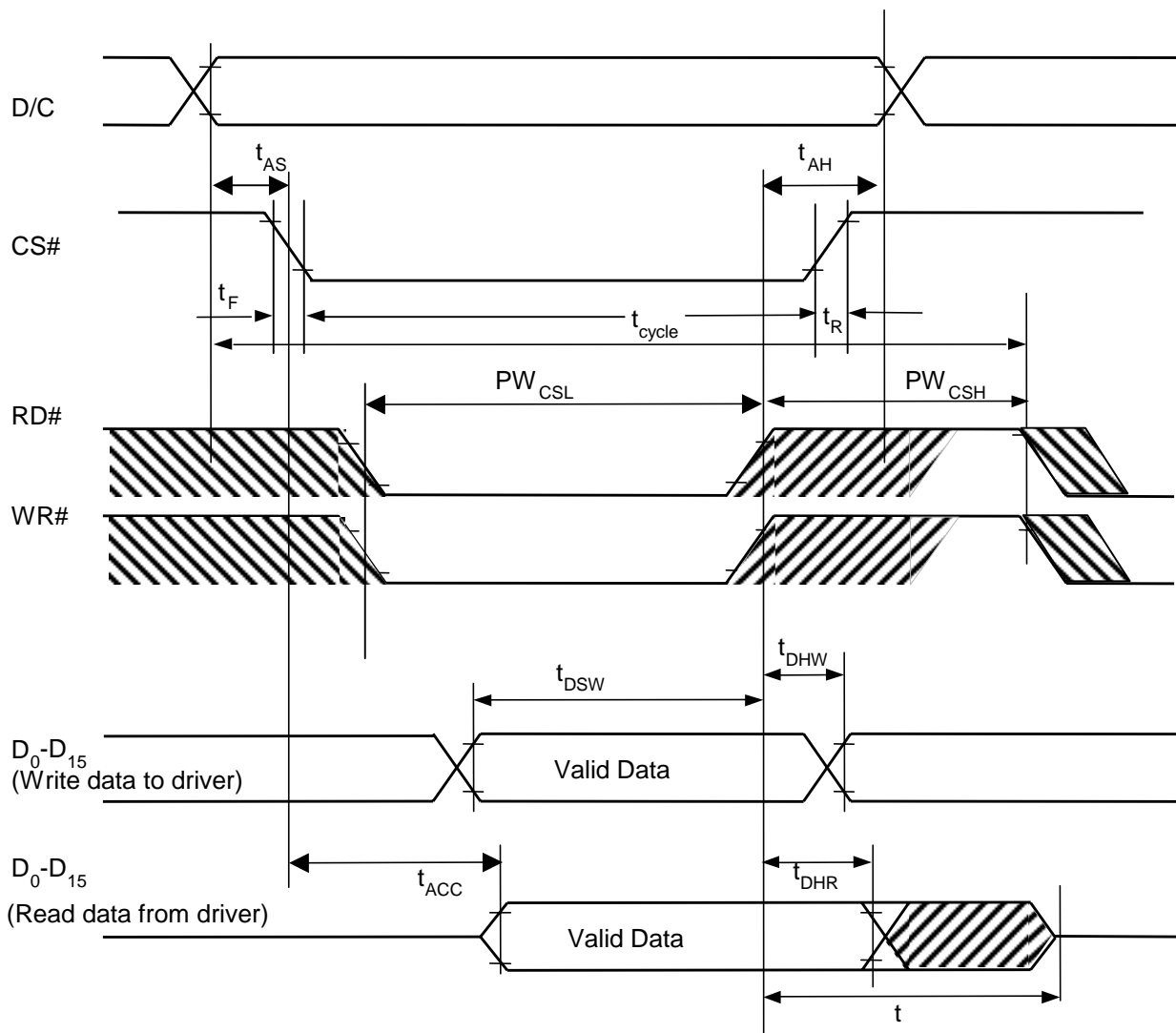

Figure 28 - 8080-series MPU parallel interface characteristics

Table 15 - Serial Interface Timing Characteristics

($V_{DD} - V_{SS} = 2.4$ to $3.5V$, $T_A = -40$ to $85^\circ C$)

Symbol	Parameter	Min	Typ	Max	Unit
t_{cycle}	Clock Cycle Time	250	-	-	ns
t_{AS}	Address Setup Time	150	-	-	ns
t_{AH}	Address Hold Time	150	-	-	ns
t_{CSS}	Chip Select Setup Time	120	-	-	ns
t_{CSH}	Chip Select Hold Time	60	-	-	ns
t_{DSW}	Write Data Setup Time	100	-	-	ns
t_{DHW}	Write Data Hold Time	100	-	-	ns
t_{CLKL}	Clock Low Time	100	-	-	ns
t_{CLKH}	Clock High Time	100	-	-	ns
t_R	Rise Time	-	-	15	ns
t_F	Fall Time	-	-	15	ns

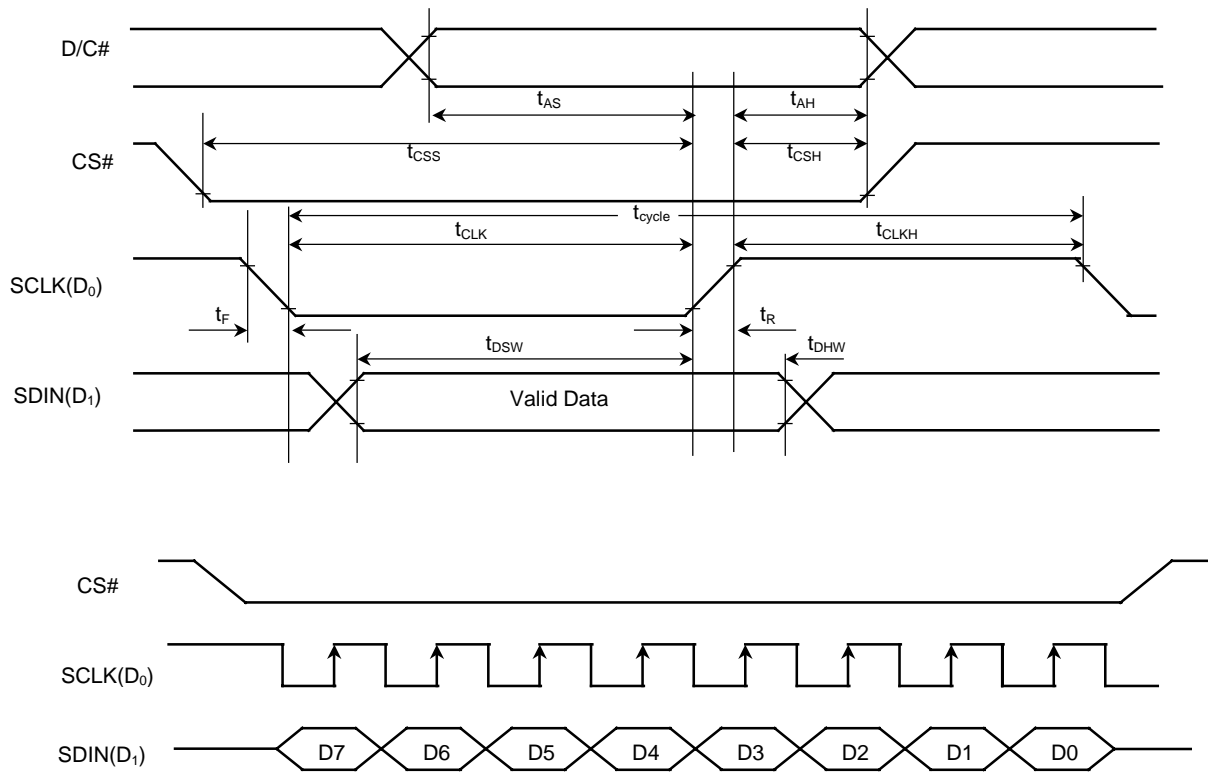
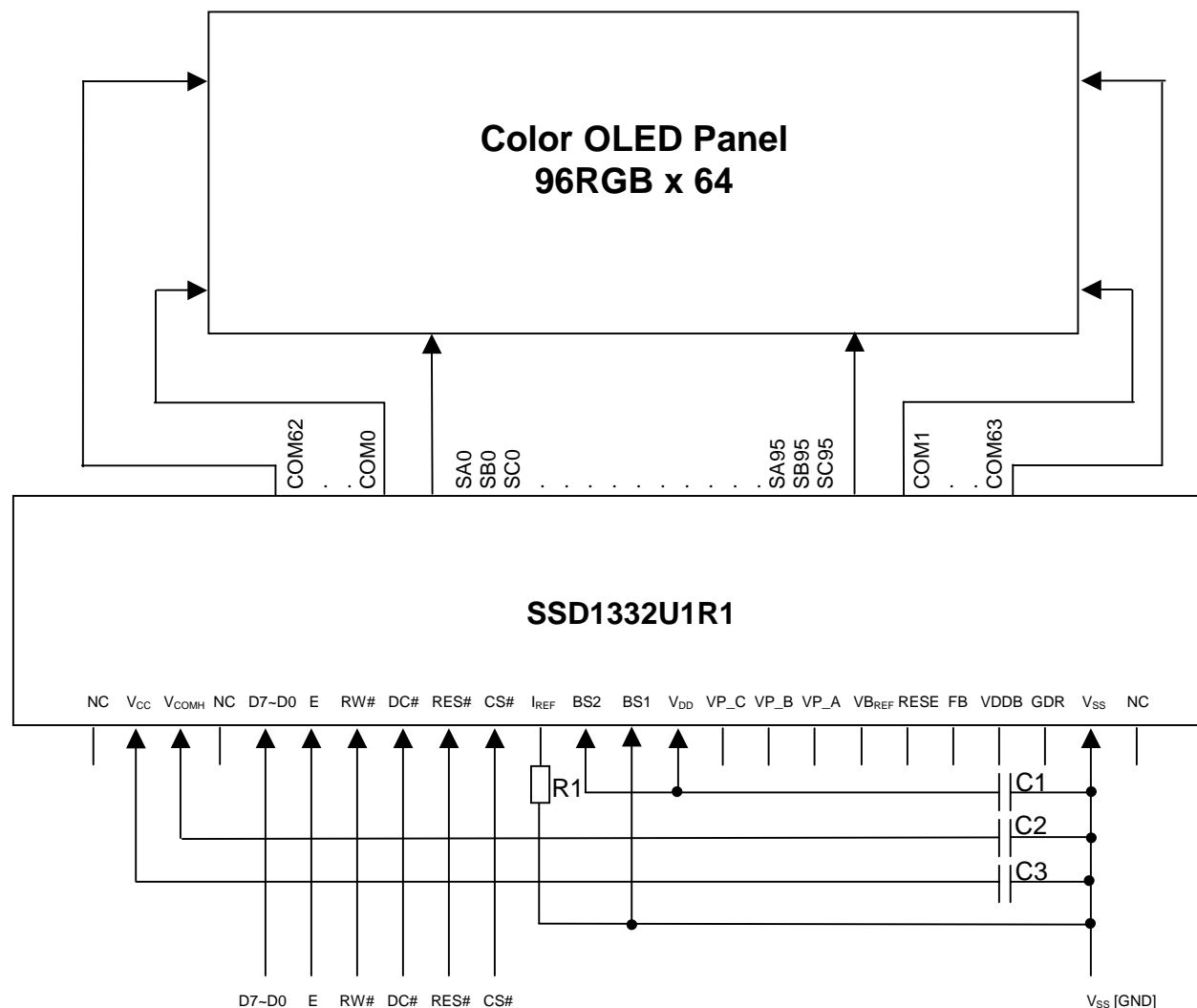

Figure 29 - Serial interface characteristics

14 APPLICATION EXAMPLE

The configuration for 6800-parallel interface mode, externally V_{CC} is shown in the following diagram:
 ($V_{DD} = 3.0V$, external $V_{CC} = 12V$, $I_{REF} = 10\mu A$)



Pin connected to MCU interface: D0~D7, E, R/W#, D/C#, RES#, CS#

Pin internally connected to V_{DD} : M/S#, CLS

Pin internally connected to V_{SS} : VSSB

Pin internally connected to V_{CC} : VREF

Pin externally connected to V_{DD} : BS2

Pin externally connected to V_{SS} : BS1

Pin floated: VP_C, VP_B, VP_A, VBREF, RESE, FB, VDDB, GDR

C1~C3: 4.7uF

Voltage at $I_{REF} = V_{CC} - 3V$

$R1 = (\text{Voltage at } I_{REF} - V_{SS}) / I_{REF} = 910K\Omega$

Figure 30 - Application Example for SSD1332U1R1

15 SSD1332U1R1 COF PACKAGE DIMENSIONS



TAPE
UN-WINDING
DIRECTION

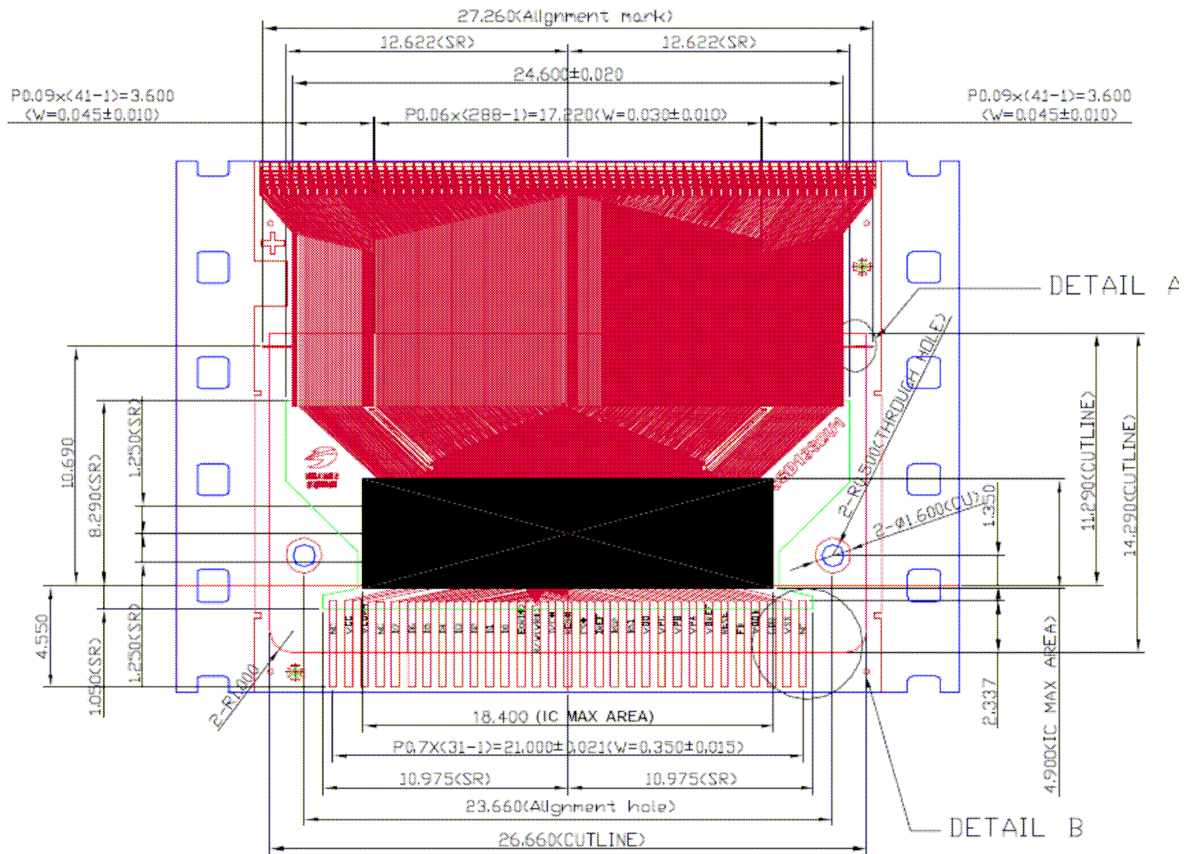

NOTE:

1. GENERAL TOLERANCE: ±0.05mm
2. MATERIAL
 - PI: KAPTON (150EN) 38±4um
 - CU: 8±2um
 - SR: SN9000 15±10um
 - (OTHER TOLERANCE: ±0.200)
3. SN PLATING: 0.15±0.05um
4. TAP SITE: 5 SPH, 23.75mm

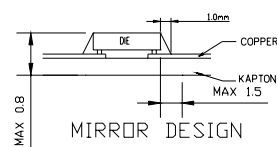
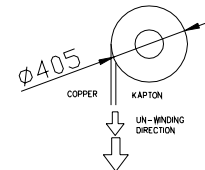

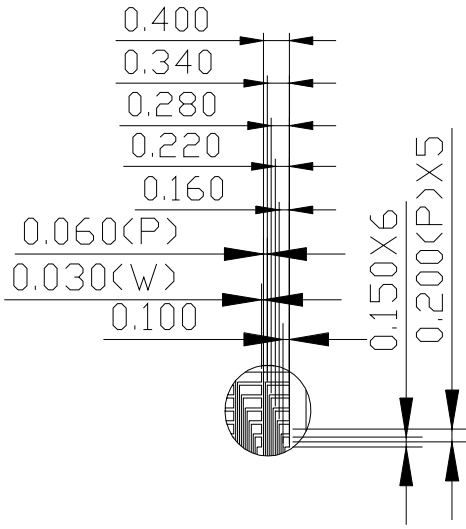

DETAIL A:
TEST PAD

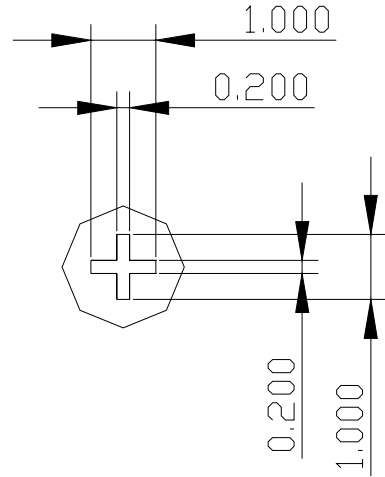

DETAIL B

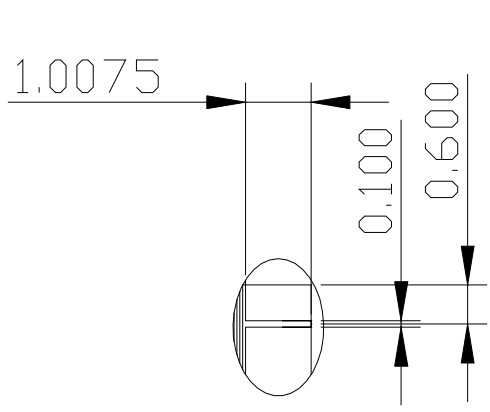

DETAIL C

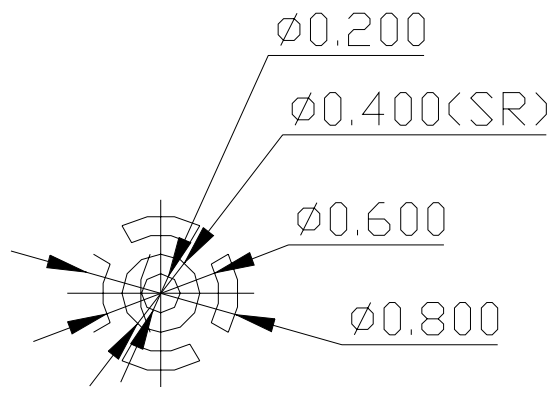

SR ALIGNMENT MARK
SCALE 3:1

16 SSD1332U1R1 COF PIN ASSIGNMENT

1	NC	401	NC
2	VCC	400	NC
3	VCOMH	399	NC
4	NC	398	COM62
5	D7	397	COM60
6	D6	396	COM58
7	D5		
8	D4	369	COM4
9	D3	368	COM2
10	D2	367	COM0
11	D1	366	NC
12	D0	365	NC
13	E<RD>	364	NC
14	RW#<WR>	363	NC
15	DC#	362	NC
16	RES#	361	NC
17	CS#	360	SA0
18	IREF	359	SB0
19	BS2	358	SC0
20	BS1		
21	VDD	75	SA95
22	VP_C	74	SB95
23	VP_B	73	SC95
24	VP_A	72	NC
25	VBREF	71	NC
26	RESE	70	NC
27	FB	69	NC
28	VDDB	68	NC
29	GDR	67	NC
30	VSS	66	COM1
31	NC	65	COM3
		64	COM5
		37	ROW59
		36	ROW61
		35	COM63
		34	NC
		33	NC
		32	NC

Figure 31 - SSD1332U1R1 COF pin assignment

Pin #	Pin name	Pin #	Pin name	Pin #	Pin name	Pin #	Pin name	Pin #	Pin name
1	NC	81	SA93	161	SB66	241	SC39	321	SA13
2	VCC	82	SC92	162	SA66	242	SB39	322	SC12
3	VCOMH	83	SB92	163	SC65	243	SA39	323	SB12
4	NC	84	SA92	164	SB65	244	SC38	324	SA12
5	D7	85	SC91	165	SA65	245	SB38	325	SC11
6	D6	86	SB91	166	SC64	246	SA38	326	SB11
7	D5	87	SA91	167	SB64	247	SC37	327	SA11
8	D4	88	SC90	168	SA64	248	SB37	328	SC10
9	D3	89	SB90	169	SC63	249	SA37	329	SB10
10	D2	90	SA90	170	SB63	250	SC36	330	SA10
11	D1	91	SC89	171	SA63	251	SB36	331	SC9
12	D0	92	SB89	172	SC62	252	SA36	332	SB9
13	E(RD#)	93	SA89	173	SB62	253	SC35	333	SA9
14	R/W#(WR#)	94	SC88	174	SA62	254	SB35	334	SC8
15	D/C#	95	SB88	175	SC61	255	SA35	335	SB8
16	RES	96	SA88	176	SB61	256	SC34	336	SA8
17	CS#	97	SC87	177	SA61	257	SB34	337	SC7
18	IREF	98	SB87	178	SC60	258	SA34	338	SB7
19	BS2	99	SA87	179	SB60	259	SC33	339	SA7
20	BS1	100	SC86	180	SA60	260	SB33	340	SC6
21	VDD	101	SB86	181	SC59	261	SA33	341	SB6
22	VP_C	102	SA86	182	SB59	262	SC32	342	SA6
23	VP_B	103	SC85	183	SA59	263	SB32	343	SC5
24	VP_A	104	SB85	184	SC58	264	SA32	344	SB5
25	VBREF	105	SA85	185	SB58	265	SC31	345	SA5
26	RESE	106	SC84	186	SA58	266	SB31	346	SC4
27	FB	107	SB84	187	SC57	267	SA31	347	SB4
28	VDDB	108	SA84	188	SB57	268	SC30	348	SA4
29	GDR	109	SC83	189	SA57	269	SB30	349	SC3
30	VSS	110	SB83	190	SC56	270	SA30	350	SB3
31	NC	111	SA83	191	SB56	271	SC29	351	SA3
32	NC	112	SC82	192	SA56	272	SB29	352	SC2
33	NC	113	SB82	193	SC55	273	SA29	353	SB2
34	NC	114	SA82	194	SB55	274	SC28	354	SA2
35	COM63	115	SC81	195	SA55	275	SB28	355	SC1
36	COM61	116	SB81	196	SC54	276	SA28	356	SB1
37	COM59	117	SA81	197	SB54	277	SC27	357	SA1
38	COM57	118	SC80	198	SA54	278	SB27	358	SC0
39	COM55	119	SB80	199	SC53	279	SA27	359	SB0
40	COM53	120	SA80	200	SB53	280	SC26	360	SA0
41	COM51	121	SC79	201	SA53	281	SB26	361	NC
42	COM49	122	SB79	202	SC52	282	SA26	362	NC
43	COM47	123	SA79	203	SB52	283	SC25	363	NC
44	COM45	124	SC78	204	SA52	284	SB25	364	NC
45	COM43	125	SB78	205	SC51	285	SA25	365	NC
46	COM41	126	SA78	206	SB51	286	SC24	366	NC
47	COM39	127	SC77	207	SA51	287	SB24	367	COM0
48	COM37	128	SB77	208	SC50	288	SA24	368	COM2
49	COM35	129	SA77	209	SB50	289	SC23	369	COM4
50	COM33	130	SC76	210	SA50	290	SB23	370	COM6
51	COM31	131	SB76	211	SC49	291	SA23	371	COM8
52	COM29	132	SA76	212	SB49	292	SC22	372	COM10
53	COM27	133	SC75	213	SA49	293	SB22	373	COM12
54	COM25	134	SB75	214	SC48	294	SA22	374	COM14
55	COM23	135	SA75	215	SB48	295	SC21	375	COM16
56	COM21	136	SC74	216	SA48	296	SB21	376	COM18
57	COM19	137	SB74	217	SC47	297	SA21	377	COM20
58	COM17	138	SA74	218	SB47	298	SC20	378	COM22
59	COM15	139	SC73	219	SA47	299	SB20	379	COM24
60	COM13	140	SB73	220	SC46	300	SA20	380	COM26
61	COM11	141	SA73	221	SB46	301	SC19	381	COM28
62	COM9	142	SC72	222	SA46	302	SB19	382	COM30
63	COM7	143	SB72	223	SC45	303	SA19	383	COM32
64	COM5	144	SA72	224	SB45	304	SC18	384	COM34
65	COM3	145	SC71	225	SA45	305	SB18	385	COM36
66	COM1	146	SB71	226	SC44	306	SA18	386	COM38
67	NC	147	SA71	227	SB44	307	SC17	387	COM40
68	NC	148	SC70	228	SA44	308	SB17	388	COM42
69	NC	149	SB70	229	SC43	309	SA17	389	COM44
70	NC	150	SA70	230	SB43	310	SC16	390	COM46
71	NC	151	SC69	231	SA43	311	SB16	391	COM48
72	NC	152	SB69	232	SC42	312	SA16	392	COM50
73	SC95	153	SA69	233	SB42	313	SC15	393	COM52
74	SB95	154	SC68	234	SA42	314	SB15	394	COM54
75	SA95	155	SB68	235	SC41	315	SA15	395	COM56
76	SC94	156	SA68	236	SB41	316	SC14	396	COM58
77	SB94	157	SC67	237	SA41	317	SB14	397	COM60
78	SA94	158	SB67	238	SC40	318	SA14	398	COM62
79	SC93	159	SA67	239	SB40	319	SC13	399	NC
80	SB93	160	SC66	240	SA40	320	SB13	400	NC
								401	NC

Table 16 - SSD1332U1R1 COF pin assignment

17 SSD1332T1R1 TAB PACKAGE DIMENSIONS

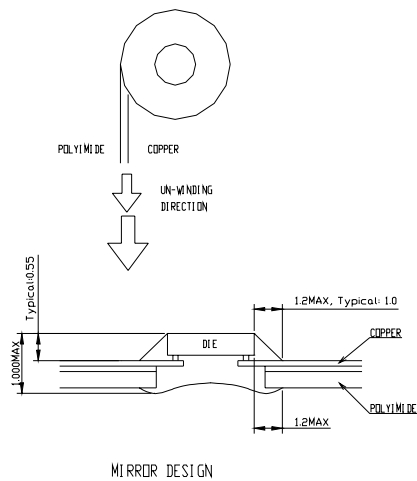
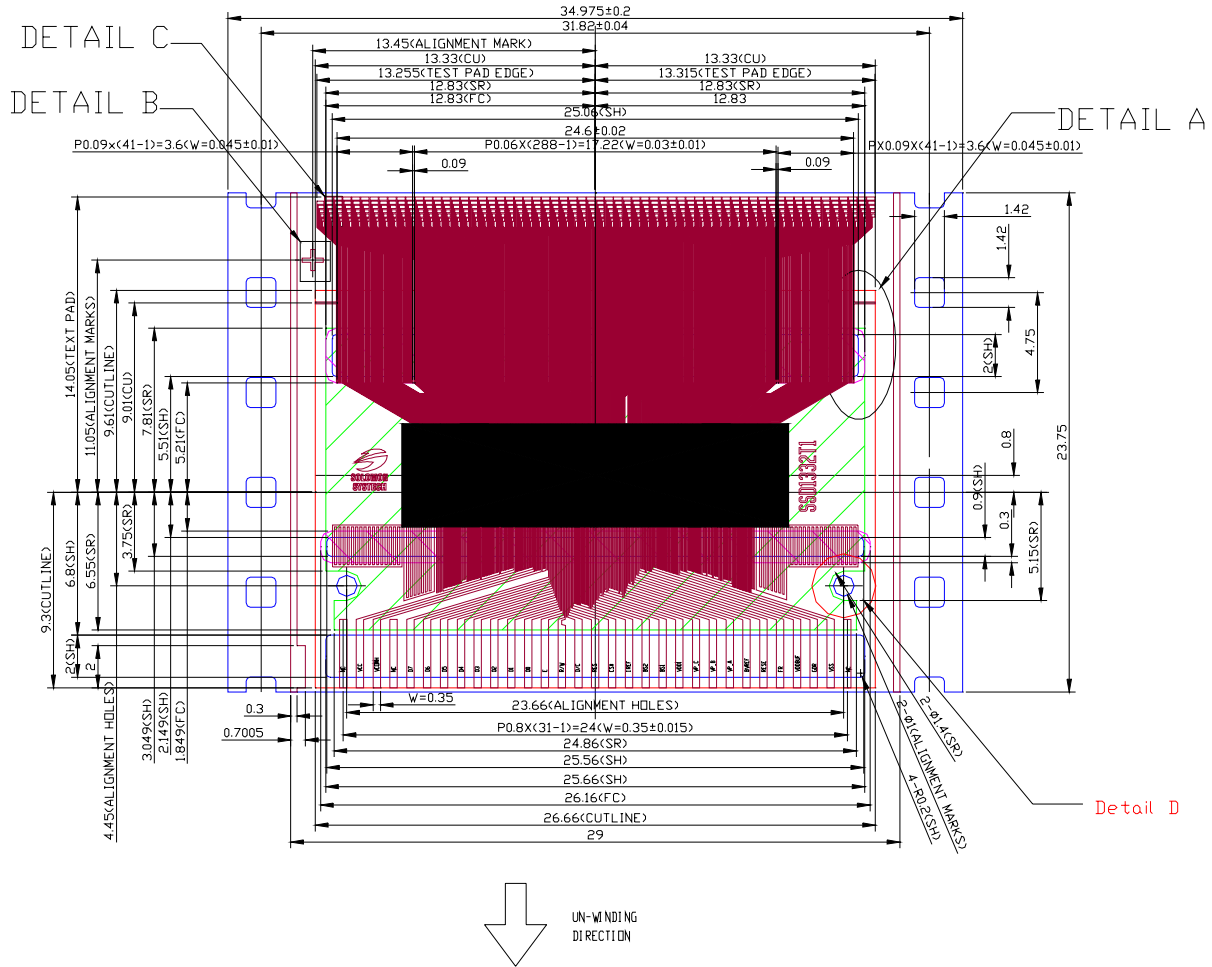

- NOTE:
1. GENERAL TOLERANCE: $\pm 0.05\text{mm}$
 2. CUTLINE TOLERANCE: $\pm 0.15\text{mm}$
 3. MATERIAL
 - PI: $75 \pm 6\mu\text{m}$
 - CU: $15\mu\text{m}$
 - SR: $15 \pm 10\mu\text{m}$
 - (OTHER TOLERANCE: ± 0.200)
 4. SN PLATING: $0.20 \pm 0.05\mu\text{m}$
 5. TAPSITE: 5 SPH, 23.75mm
 6. OPTIONAL FEATURE FOR SOLOMON SYSTEMCH INTERNAL USE ONLY WHICH MAYBE REPLACED BY PUNCHING HOLE

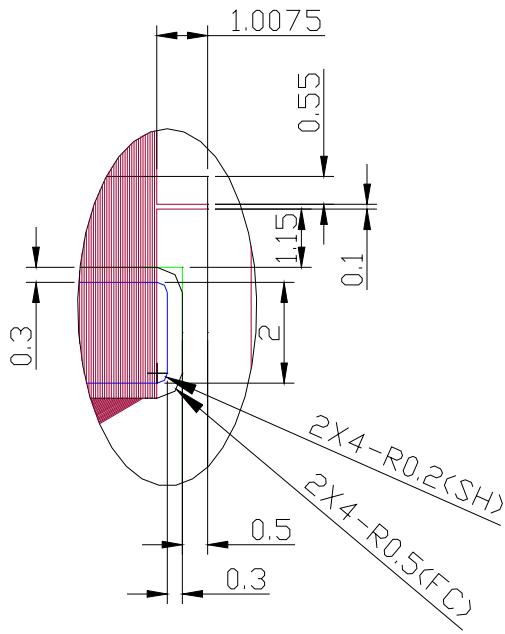

Detail A

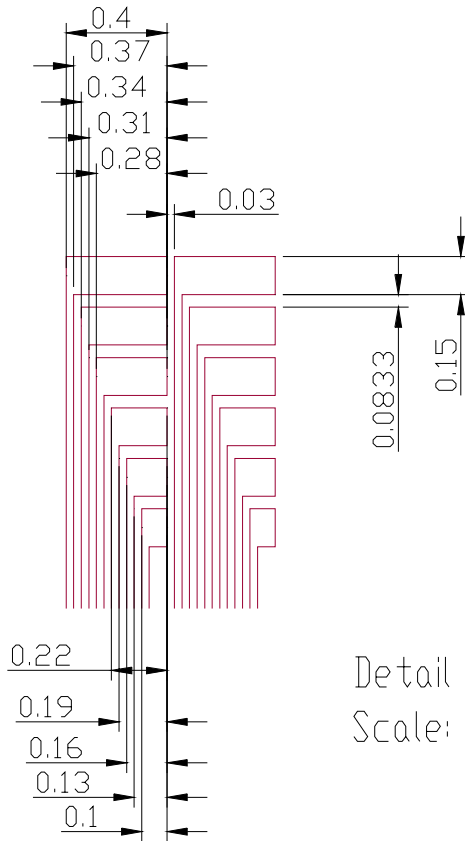

Detail C
Scale: 5:1

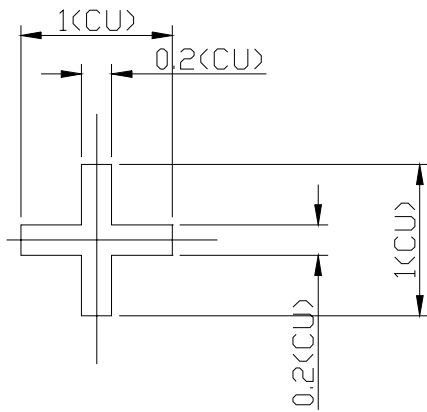

Detail B
Scale: 3:1

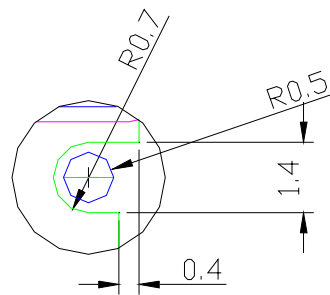

Detail D

18 SSD1332T1R1 TAB PIN ASSIGNMENT

Figure 32 - SSD1332T1R1 TAB pin assignment

1	NC	401	NC
2	VCC	400	NC
3	VCOMH	399	NC
4	NC	398	COM62
5	D7	397	COM60
6	D6	396	COM58
7	D5	369	COM4
8	D4	368	COM2
9	D3	367	COM0
10	D2	366	NC
11	D1	365	NC
12	D0	364	NC
13	E	363	NC
14	R/W	362	NC
15	D/C	361	NC
16	RES#	360	SA0
17	CS#	359	SB0
18	IREF	358	SC0
19	BS2	75	SA95
20	BS1	74	SB95
21	VDD	73	SC95
22	VP_C	72	NC
23	VP_B	71	NC
24	VP_A	70	NC
25	BVREF	69	NC
26	RESE	68	NC
27	FR	67	NC
28	VDDB	66	COM1
29	GDR	65	COM3
30	VSS	64	COM5
31	NC	37	COM61
		36	COM63
		35	NC
		34	NC
		33	NC
		32	NC

Pad.no	Pad.name	Pad.no	Pad.name	Pad.no	Pad.name	Pad.no	Pad.name	Pad.no	Pad.name	Pad.no	Pad.name	Pad.no	Pad.name
1	NC	61	COM11	121	SC79	181	SC59	241	SC39	301	SC19	361	NC
2	VCC	62	COM9	122	SB79	182	SB59	242	SB39	302	SB19	362	NC
3	VCOMH	63	COM7	123	SA79	183	SA59	243	SA39	303	SA19	363	NC
4	NC	64	COM5	124	SC78	184	SC58	244	SC38	304	SC18	364	NC
5	D7	65	COM3	125	SB78	185	SB58	245	SB38	305	SB18	365	NC
6	D6	66	COM1	126	SA78	186	SA58	246	SA38	306	SA18	366	NC
7	D5	67	NC	127	SC77	187	SC57	247	SC37	307	SC17	367	COM0
8	D4	68	NC	128	SB77	188	SB57	248	SB37	308	SB17	368	COM2
9	D3	69	NC	129	SA77	189	SA57	249	SA37	309	SA17	369	COM4
10	D2	70	NC	130	SC76	190	SC56	250	SC36	310	SC16	370	COM6
11	D1	71	NC	131	SB76	191	SB56	251	SB36	311	SB16	371	COM8
12	D0	72	NC	132	SA76	192	SA56	252	SA36	312	SA16	372	COM10
13	E	73	SC95	133	SC75	193	SC55	253	SC35	313	SC15	373	COM12
14	R/W	74	SB95	134	SB75	194	SB55	254	SB35	314	SB15	374	COM14
15	D/C	75	SA95	135	SA75	195	SA55	255	SA35	315	SA15	375	COM16
16	RES#	76	SC94	136	SC74	196	SC54	256	SC34	316	SC14	376	COM18
17	CS#	77	SB94	137	SB74	197	SB54	257	SB34	317	SB14	377	COM20
18	IREF	78	SA94	138	SA74	198	SA54	258	SA34	318	SA14	378	COM22
19	BS2	79	SC93	139	SC73	199	SC53	259	SC33	319	SC13	379	COM24
20	BS1	80	SB93	140	SB73	200	SB53	260	SB33	320	SB13	380	COM26
21	VDD	81	SA93	141	SA73	201	SA53	261	SA33	321	SA13	381	COM28
22	VP_C	82	SC92	142	SC72	202	SC52	262	SC32	322	SC12	382	COM30
23	VP_B	83	SB92	143	SB72	203	SB52	263	SB32	323	SB12	383	COM32
24	VP_A	84	SA92	144	SA72	204	SA52	264	SA32	324	SA12	384	COM34
25	BVREF	85	SC91	145	SC71	205	SC51	265	SC31	325	SC11	385	COM36
26	RESE	86	SB91	146	SB71	206	SB51	266	SB31	326	SB11	386	COM38
27	FR	87	SA91	147	SA71	207	SA51	267	SA31	327	SA11	387	COM40
28	VDDB	88	SC90	148	SC70	208	SC50	268	SC30	328	SC10	388	COM42
29	GDR	89	SB90	149	SB70	209	SB50	269	SB30	329	SB10	389	COM44
30	VSS	90	SA90	150	SA70	210	SA50	270	SA30	330	SA10	390	COM46
31	NC	91	SC89	151	SC69	211	SC49	271	SC29	331	SC9	391	COM48
32	NC	92	SB89	152	SB69	212	SB49	272	SB29	332	SB9	392	COM50
33	NC	93	SA89	153	SA69	213	SA49	273	SA29	333	SA9	393	COM52
34	NC	94	SC88	154	SC68	214	SC48	274	SC28	334	SC8	394	COM54
35	COM63	95	SB88	155	SB68	215	SB48	275	SB28	335	SB8	395	COM56
36	COM61	96	SA88	156	SA68	216	SA48	276	SA28	336	SA8	396	COM58
37	COM59	97	SC87	157	SC67	217	SC47	277	SC27	337	SC7	397	COM60
38	COM57	98	SB87	158	SB67	218	SB47	278	SB27	338	SB7	398	COM62
39	COM55	99	SA87	159	SA67	219	SA47	279	SA27	339	SA7	399	NC
40	COM53	100	SC86	160	SC66	220	SC46	280	SC26	340	SC6	400	NC
41	COM51	101	SB86	161	SB66	221	SB46	281	SB26	341	SB6	401	NC
42	COM49	102	SA86	162	SA66	222	SA46	282	SA26	342	SA6		
43	COM47	103	SC85	163	SC65	223	SC45	283	SC25	343	SC5		
44	COM45	104	SB85	164	SB65	224	SB45	284	SB25	344	SB5		
45	COM43	105	SA85	165	SA65	225	SA45	285	SA25	345	SA5		
46	COM41	106	SC84	166	SC64	226	SC44	286	SC24	346	SC4		
47	COM39	107	SB84	167	SB64	227	SB44	287	SB24	347	SB4		
48	COM37	108	SA84	168	SA64	228	SA44	288	SA24	348	SA4		
49	COM35	109	SC83	169	SC63	229	SC43	289	SC23	349	SC3		
50	COM33	110	SB83	170	SB63	230	SB43	290	SB23	350	SB3		
51	COM31	111	SA83	171	SA63	231	SA43	291	SA23	351	SA3		
52	COM29	112	SC82	172	SC62	232	SC42	292	SC22	352	SC2		
53	COM27	113	SB82	173	SB62	233	SB42	293	SB22	353	SB2		
54	COM25	114	SA82	174	SA62	234	SA42	294	SA22	354	SA2		
55	COM23	115	SC81	175	SC61	235	SC41	295	SC21	355	SC1		
56	COM21	116	SB81	176	SB61	236	SB41	296	SB21	356	SB1		
57	COM19	117	SA81	177	SA61	237	SA41	297	SA21	357	SA1		
58	COM17	118	SC80	178	SC60	238	SC40	298	SC20	358	SC0		
59	COM15	119	SB80	179	SB60	239	SB40	299	SB20	359	SB0		
60	COM13	120	SA80	180	SA60	240	SA40	300	SA20	360	SA0		

Table 17 - SSD1332T1R1 TAB pin assignment

19 SSD1332Z PACKAGE DETAILS

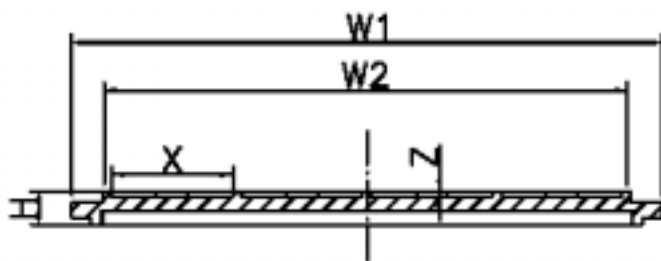
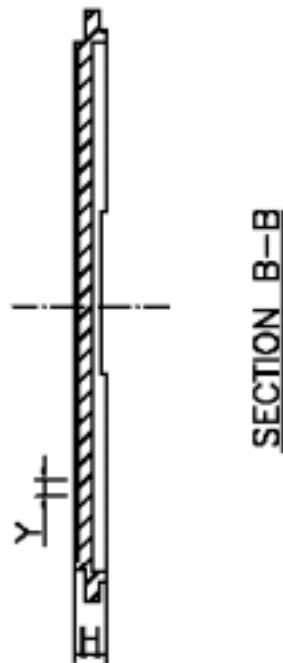
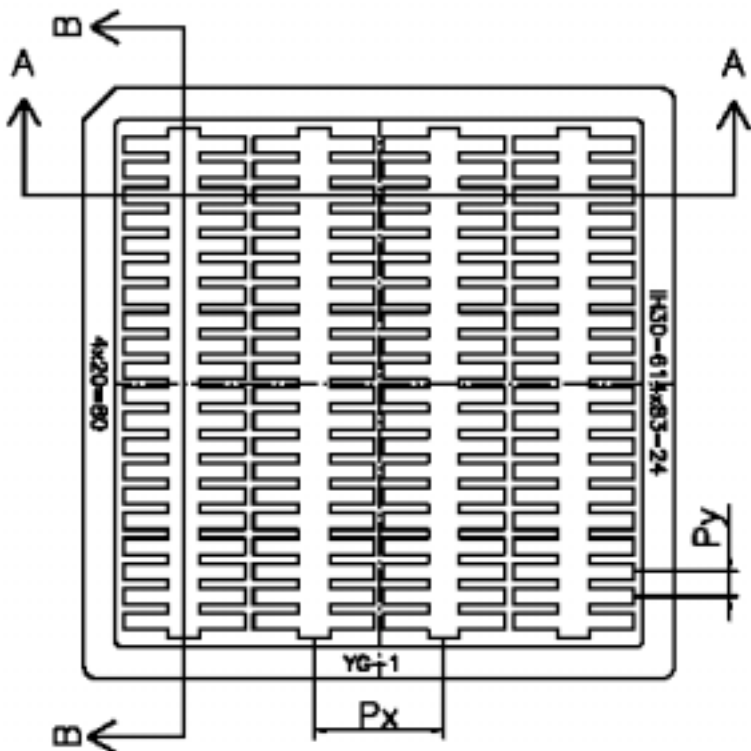

SECTION A-A

	Spec	
	mm	(mil)
W1	76.0 +0.2/-0.1	(2992)
W2	68.0 +0.2/-0.1	(2677)
H	4.20 +/-0.1	(165)
Px	20.36 +/-0.1	(802)
Py	3.23 +/-0.1	(127)
X	15.60 +/-	(614)
Y	2.10 +/-	(83)
Z	0.61 +/-0.05	(24)
N	80	

Solomon Systech reserves the right to make changes without further notice to any products herein. Solomon Systech makes no warranty, representation or guarantee regarding the suitability of its products for any particular purpose, nor does Solomon Systech assume any liability arising out of the application or use of any product or circuit, and specifically disclaims any and all liability, including without limitation consequential or incidental damages. "Typical" parameters can and do vary in different applications. All operating parameters, including "Typicals" must be validated for each customer application by customer's technical experts. Solomon Systech does not convey any license under its patent rights nor the rights of others. Solomon Systech products are not designed, intended, or authorized for use as components in systems intended for surgical implant into the body, or other applications intended to support or sustain life, or for any other application in which the failure of the Solomon Systech product could create a situation where personal injury or death may occur. Should Buyer purchase or use Solomon Systech products for any such unintended or unauthorized application, Buyer shall indemnify and hold Solomon Systech and its offices, employees, subsidiaries, affiliates, and distributors harmless against all claims, costs, damages, and expenses, and reasonable attorney fees arising out of, directly or indirectly, any claim of personal injury or death associated with such unintended or unauthorized use, even if such claim alleges that Solomon Systech was negligent regarding the design or manufacture of the part.

With collaboration of <https://www.displayfuture.com>