

SA3086

80 CH SEGMENT /COMMON DRIVER FOR DOT MATRIX LCD

INTRODUCTION

The SA3086 is an LCD driver LSI which is fabricated by low power CMOS high voltage process technology. In segment driver mode, it can be interfaced in 1-bit serial or 4-bit parallel method by the controller. In common driver mode, dual type mode is applicable. And in segment mode application, the power down function reduces power consumption.

FEATURES

- Power supply voltage: + 5V \pm 10 %, + 3V \pm 10%
- Supply voltage for display: 6 to 28 V (V_{DD} - V_{EE})
- 4-bit parallel / 1-bit serial data processing (in segment mode)
- Single mode operation / dual mode operation (in common mode)
- Power down function (in segment mode)
- Applicable LCD duty 1/64 – 1/256
- Interface

| DRIVERS | |
|---------------|---------------|
| COM (cascade) | SEG (cascade) |
| SA3086 | SA3086 |

- High voltage CMOS process
- Bare die

PAD LOCATION

| No. | NAME | X | Y |
|-----|------|----------|----------|
| 1 | SC51 | -1155.00 | 1684.00 |
| 2 | SC52 | -1344.00 | 1540.00 |
| 3 | SC53 | -1344.00 | 1430.00 |
| 4 | SC54 | -1344.00 | 1320.00 |
| 5 | SC55 | -1344.00 | 1210.00 |
| 6 | SC56 | -1344.00 | 1100.00 |
| 7 | SC57 | -1344.00 | 990.00 |
| 8 | SC58 | -1344.00 | 880.00 |
| 9 | SC59 | -1344.00 | 770.00 |
| 10 | SC60 | -1344.00 | 660.00 |
| 11 | SC61 | -1344.00 | 550.00 |
| 12 | SC62 | -1344.00 | 440.00 |
| 13 | SC63 | -1344.00 | 330.00 |
| 14 | SC64 | -1344.00 | 220.00 |
| 15 | SC65 | -1344.00 | 110.00 |
| 16 | SC66 | -1344.00 | 0.00 |
| 17 | SC67 | -1344.00 | -110.00 |
| 18 | SC68 | -1344.00 | -220.00 |
| 19 | SC69 | -1344.00 | -330.00 |
| 20 | SC70 | -1344.00 | -440.00 |
| 21 | SC71 | -1344.00 | -550.00 |
| 22 | SC72 | -1344.00 | -660.00 |
| 23 | SC73 | -1344.00 | -770.00 |
| 24 | SC74 | -1344.00 | -880.00 |
| 25 | SC75 | -1344.00 | -990.00 |
| 26 | SC76 | -1344.00 | -1100.00 |
| 27 | SC77 | -1344.00 | -1210.00 |
| 28 | SC78 | -1344.00 | -1320.00 |
| 29 | SC79 | -1344.00 | -1430.00 |
| 30 | SC80 | -1344.00 | -1540.00 |
| 31 | ERB | -1090.00 | -1684.00 |
| 32 | VEE | -934.40 | -1684.00 |
| 33 | V5 | -824.40 | -1684.00 |
| 34 | V43 | -714.40 | -1684.00 |

| No. | NAME | Y | Y |
|-----|----------|---------|----------|
| 35 | V12 | -604.40 | -1684.00 |
| 36 | V0 | -494.40 | -1684.00 |
| 37 | CS | -334.70 | -1684.00 |
| 38 | M | -224.70 | -1684.00 |
| 39 | DISPOFFB | -114.70 | -1684.00 |
| 40 | VDD | -4.70 | -1684.00 |
| 41 | SHL | 105.30 | -1684.00 |
| 42 | GND | 215.30 | -1684.00 |
| 43 | D4 DR | 325.30 | -1684.00 |
| 44 | D3 DM | 435.30 | -1684.00 |
| 45 | D2 DL | 545.30 | -1684.00 |
| 46 | DI SID | 655.30 | -1684.00 |
| 47 | CL2 | 765.30 | -1684.00 |
| 48 | AMS | 875.30 | -1684.00 |
| 49 | CL1 | 985.30 | -1684.00 |
| 50 | ELB | 1095.30 | -1684.00 |
| 51 | SC1 | 1344.00 | -1540.00 |
| 52 | SC2 | 1344.00 | -1430.00 |
| 53 | SC3 | 1344.00 | -1320.00 |
| 54 | SC4 | 1344.00 | -1210.00 |
| 55 | SC5 | 1344.00 | -1100.00 |
| 56 | SC6 | 1344.00 | -990.00 |
| 57 | SC7 | 1344.00 | -880.00 |
| 58 | SC8 | 1344.00 | -770.00 |
| 59 | SC9 | 1344.00 | -660.00 |
| 60 | SC10 | 1344.00 | -550.00 |
| 61 | SC11 | 1344.00 | -440.00 |
| 62 | SC12 | 1344.00 | -330.00 |
| 63 | SCI'3 | 1344.00 | -220.00 |
| 64 | SC14 | 1344.00 | -110.00 |
| 65 | SC15 | 1344.00 | 0.00 |
| 66 | SC16 | 1344.00 | 110.00 |
| 67 | SC17 | 1344.00 | 220.00 |
| 68 | SC18 | 1344.00 | 330.00 |

| No. | NAME | X | Y |
|-----|------|----------|----------|
| 69 | SC19 | 1344.00 | 440.00 |
| 70 | SC20 | 1344.00 | 550.00 |
| 71 | SC21 | 1344.00 | 660.00 |
| 72 | SC22 | 1344.00 | 770.00 |
| 73 | SC23 | 1344.00 | 880.00 |
| 74 | SC24 | 1344.00 | 990.00 |
| 75 | SC25 | 1344.00 | 1100.00 |
| 76 | SC26 | 1344.00 | 1210.00 |
| 77 | SC27 | 1344.00 | 1320.00 |
| 78 | SC28 | 1344.00 | 1430.00 |
| 79 | SC29 | 1344.00 | 1540.00 |
| 80 | SC30 | 1155.00 | 1684.00 |
| 81 | SC31 | 1045.00 | 1684.00 |
| 82 | SC32 | 935.00 | 1.684.00 |
| 83 | SC33 | 825.00 | 1684.00 |
| 84 | SC34 | 715.00 | 1684.00 |
| 85 | SC35 | 605.00 | 1684.00 |
| 86 | SC36 | 495.00 | 1684.00 |
| 87 | SC37 | 385.00 | 1684.00 |
| 88 | SC38 | 275.00 | 1684.00 |
| 89 | SC39 | 165.00 | 1684.00 |
| 90 | SC40 | 55.00 | 1684.00 |
| 91 | SC41 | -55.00 | 1684.00 |
| 92 | SC42 | -165.00 | 1684.00 |
| 93 | SC43 | -275.00 | 1684.00 |
| 94 | SC44 | -385.00 | 1684.00 |
| 95 | SC45 | -495.00 | 1684.00 |
| 96 | SC46 | -605.00 | 1684.00 |
| 97 | SC47 | -715.00 | 1684.00 |
| 98 | SC48 | -825.00 | 1684.00 |
| 99 | SC49 | -935.00 | 1684.00 |
| 100 | SC50 | -1045.00 | 1684.00 |

BLOCK DIAGRAM

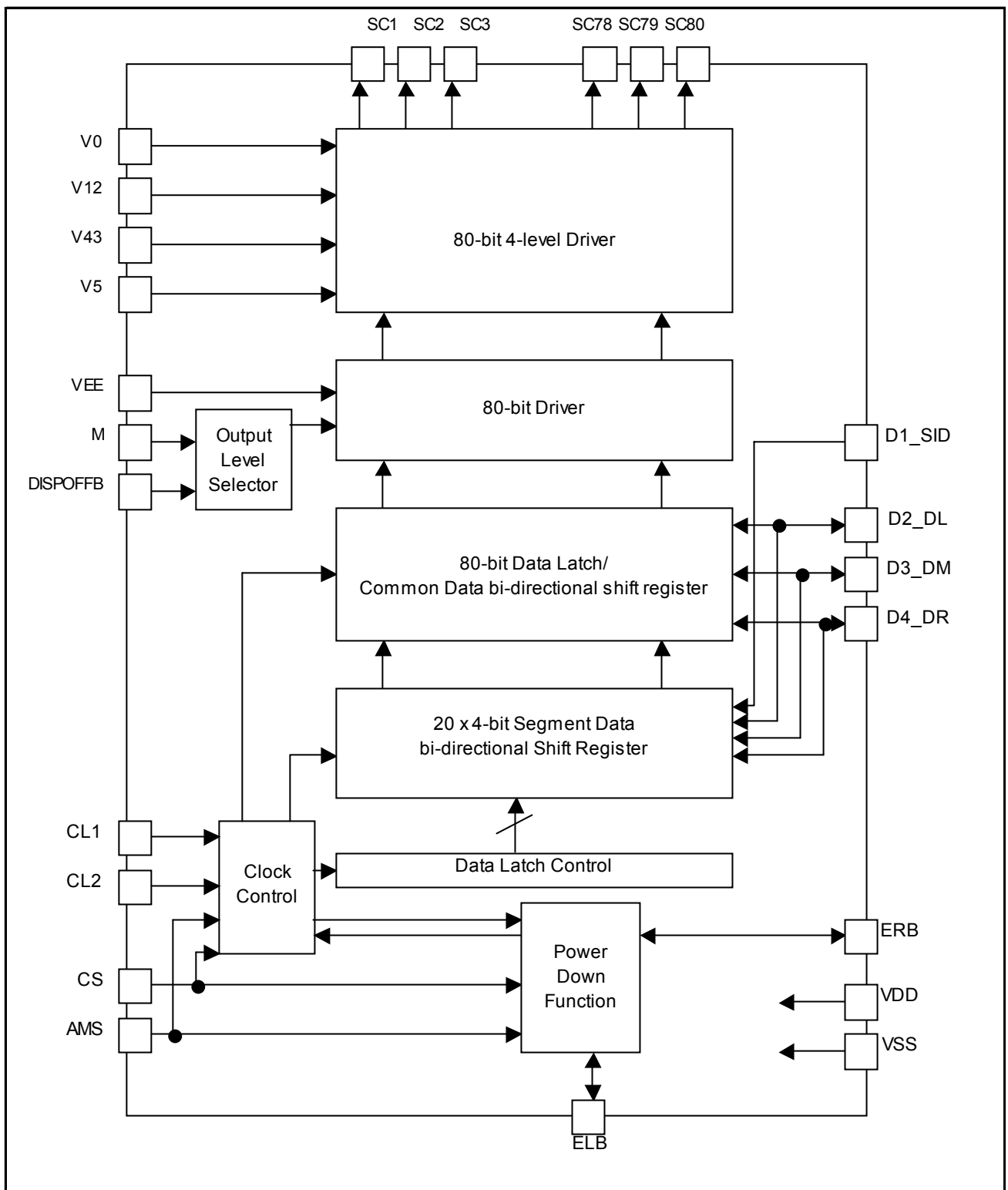

BLOCK DESCRIPTION

| Name | Function | COM/SEG |
|--|--|---------|
| Clock control | <p>Generates latch clock (LCK), shift clock (SCK) and control clock timing according to the input of CL1, CL2 and control inputs (CS, AMS).</p> <p>In case of common driver application, this block generates shift clock (LCK) for the common data bidirectional shift register.</p> | COM/SEG |
| Data latch control | <p>Determines the direction of segment data shift, and input data of each bidirectional shift register. In case of 4-bit segment data parallel transfer mode, data is shifted by 4-bit unit. In case of common driver application mode, data is transferred to the common data shift register directly, so this block is not work.</p> | SEG |
| Power down function | <p>Controls the clock enable state of current driver according to the input value of enable pin (ELB or ERB). If enable input value is "Low", every clock of the current driver is enabled and the clock control block works. But if enable input is "High", current driver is disabled and the input data value has no effect to the output level. So power consumption can be lowered.</p> | SEG |
| Output level selector | <p>Control the output voltage level according to the input control pin (M and DISPOFFB) (refer to PIN DESCRIPTION).</p> | COM/SEG |
| 20 x 4-bit segment data bidirectional shift register | <p>Stores output data value by shifting the input values. When 1-bit serial interface mode application, all 80 shift clocks (SCK) are needed to store all the display data. But in case of 4-bit parallel transfer mode application, only 20 clocks makes the role. When common driver application mode, this block is not work.</p> | SEG |
| 80-bit data latch / common data bidirectional shift register | <p>In case of segment driver application, the data from the 20x4-bit segment data shift register are latched for segment driver output. When single-type common driver application, 1-bit input data (from DL or DR pin) is shifted and latched by the direction according to the SHL signal input. When dual-type common application mode, 80-bit register are divided by two blocks and controlled independently (refer to NOTES).</p> | COM/SEG |
| 80-bit level shifter | <p>Voltage level shifter block for high voltage part. the inputs of this block are logical voltage level and the outputs of this block are high voltage level value. And this value is input to the driver.</p> | COM/SEG |
| 80-bit 4-level driver | <p>Selects the output voltage level according to the M and latched data value. If the data value is "High" the driver output is selected voltage level (V0 or V5), and in the reverse case the driver output value is non-selected level (V12 or V43). In case of segment driver application, non-selected output value is V2 or V3. And when common driver application, this value becomes V1 or V4.</p> | COM/SEG |

PIN DESCRIPTION

| Pin (no) | Input output | Name | Description | Inter-face | | | | | | | | | | | | | | | | | | |
|---------------------------|--------------|--|--|------------|-----|------------------|---------|---|---|-------------------------------|-----|---|---|-----------------------------|---|---|------------------------------|-----|---|---|----------------------------|------------|
| V _{DD} (40) | Power | Operating Voltage | Logical "High" input port (+5V+ 10%, +3V+ 10%) | Power | | | | | | | | | | | | | | | | | | |
| V _{SS} (42) | | | 0V (GND) | | | | | | | | | | | | | | | | | | | |
| V _{EE} (32) | | Driver Supply Voltage | Logical "Low" for high voltage part | | | | | | | | | | | | | | | | | | | |
| VO, V12, V43 V5 (33-36) | Input | LCD driver output voltage level | Bias supply voltage input to drive the LCD. Bias voltage divided by the resistance is usually used as supply voltage source (refer to NOTE 2). | Power | | | | | | | | | | | | | | | | | | |
| SC1 ~ SC80 (1-30, 51-100) | Output | LCD driver output | Display data output pin which corresponds to the respective latch contents. One of V ₀ , V ₁₂ , V ₃₄ and V ₅ is selected as a display driving voltage source according to the combination of the latched data level and M signal (refer to NOTE 1). | LCD | | | | | | | | | | | | | | | | | | |
| CL2 (47) | Input | Data shift clock | <p>Clock pulse input for the bidirectional shift register.</p> <ul style="list-style-type: none"> In case of segment driver application, the data is shifted to 20 x 4-bit segment data shift register at the falling edge of this clock pulse. The clock pulse, which was input when the enable bit (ELB/ERB) is not active condition, is invalid. In case of common driver application, the data is shifted to 80-bit common data bidirectional shift register by the CL1 clock. So this clock pin is not used (Open or connect this to VDD) | Controller | | | | | | | | | | | | | | | | | | |
| M(38) | Input | Alternate signal for LCD driver output | Alternate signal input pin for LCD driving. Normal frame inversion signal is input to this pin. | Controller | | | | | | | | | | | | | | | | | | |
| CL1(49) | Input | Data latch clock | <ul style="list-style-type: none"> In case of segment driver application, this signal is used for latching the shift register contents at the falling edge of this clock pulse. CL1 pulse "High" level initializes power-down function block. In case of common driver application, CL1 is used as shifting clock of common output data. | Controller | | | | | | | | | | | | | | | | | | |
| DISPOFF B (39) | Input | Display oft control | Control input pin to fix the driver output (SC1™SC80) to VO level, during "Low" value input. LCD becomes non-selected by V0 level output from every output of segment drivers and every output of common drivers. | Controller | | | | | | | | | | | | | | | | | | |
| CS (37) | Input | COM/SEG mode control | When CS = "Low", SA3086 is used as 80-bit segment driver. When CS = "High", SA3086 is set to 80-bit common driver. | - | | | | | | | | | | | | | | | | | | |
| AMS (48) | Input | Application mode select | <p>According to the input value of the AMS and the CS pin, application mode of SA3086 is different as below.</p> <table border="1" style="margin-left: auto; margin-right: auto;"> <thead> <tr> <th>CS</th> <th>AMS</th> <th>Application mode</th> <th>COM/SEG</th> </tr> </thead> <tbody> <tr> <td>L</td> <td>L</td> <td>4-bit parallel interface mode</td> <td rowspan="2">SEG</td> </tr> <tr> <td>L</td> <td>H</td> <td>1-bit serial interface mode</td> </tr> <tr> <td>H</td> <td>L</td> <td>single-type application mode</td> <td rowspan="2">COM</td> </tr> <tr> <td>H</td> <td>H</td> <td>dual-type application mode</td> </tr> </tbody> </table> | CS | AMS | Application mode | COM/SEG | L | L | 4-bit parallel interface mode | SEG | L | H | 1-bit serial interface mode | H | L | single-type application mode | COM | H | H | dual-type application mode | Controller |
| CS | AMS | Application mode | COM/SEG | | | | | | | | | | | | | | | | | | | |
| L | L | 4-bit parallel interface mode | SEG | | | | | | | | | | | | | | | | | | | |
| L | H | 1-bit serial interface mode | | | | | | | | | | | | | | | | | | | | |
| H | L | single-type application mode | COM | | | | | | | | | | | | | | | | | | | |
| H | H | dual-type application mode | | | | | | | | | | | | | | | | | | | | |

PIN DESCRIPTION (continued)

| Pin (NO) | Input/Output | Name | Function | Interface | | | | | | | | | | | |
|-----------------------------------|--------------------|---|--|------------|----------------|--|-----|-----|---|--------------------|-------------------|---|------------------|---------------------|---|
| D1 SID, D2DL, D3DM, D4 DR (43-46) | Input/Output | Display data input / serial input data / left, right data input /output | <ul style="list-style-type: none"> In case of segment driver application, these pins are used as 4-bit data input pin (when 4-bit parallel interface mode : AMS = "Low"), or D1SID is used as serial data input pin and other pins are not used. (Open or connect this to VDD) (when 1-bit serial interface mode : AMS = "High"). In case of common driver application, the data are shifted from D2DL (D4DR) to D4DR (D2DL), when single-type application mode (AMS = "Low"). In dual-type application case, the data are shifted from D2DL and D3DM (D4DR and D3DM) to D4-DR (D2 DL). In each case the direction of data shift is determined by SHL input, (refer to NOTE 3, NOTE4) | controller | | | | | | | | | | | |
| SHL(41) | Input | Shift direction control | When SHL = "Low", data is shifted from left to right When SHL = "High", the direction is reversed, (refer to NOTE 3) | - | | | | | | | | | | | |
| ELB,ERB (50,31) | Input/Output | Enable data input/output | <ul style="list-style-type: none"> In case of segment driver application, only when enable input (ELB or ERB) is "Low", the internal operation is enabled (power down function). When several drivers are serially connected, the enable state of each driver is shifted according to the SHL input. (refer to NOTE 4) <table border="1" style="width: 100%; border-collapse: collapse; text-align: center;"> <thead> <tr> <th rowspan="2">SHL</th> <th colspan="2">SEGMENT DRIVER</th> </tr> <tr> <th>ELB</th> <th>ERB</th> </tr> </thead> <tbody> <tr> <td>L</td> <td>Output (last open)</td> <td>Input (first VSS)</td> </tr> <tr> <td>H</td> <td>Input (last VSS)</td> <td>Output (first open)</td> </tr> </tbody> </table> <ul style="list-style-type: none"> In case of common driver application, power down function is not used. (Open) | SHL | SEGMENT DRIVER | | ELB | ERB | L | Output (last open) | Input (first VSS) | H | Input (last VSS) | Output (first open) | - |
| SHL | SEGMENT DRIVER | | | | | | | | | | | | | | |
| | ELB | ERB | | | | | | | | | | | | | |
| L | Output (last open) | Input (first VSS) | | | | | | | | | | | | | |
| H | Input (last VSS) | Output (first open) | | | | | | | | | | | | | |

NOTE 1. Output level control

X: Don't care

| M | Latched data | DISPOFFB | Output level (SC1 ~ SC80) | |
|---|--------------|----------|---------------------------|----------|
| | | | SEG Mode | COM Mode |
| L | L | H | V12(V2) | V12(V1) |
| L | H | H | VO | V5 |
| H | L | H | V43(V3) | V43(V4) |
| H | H | H | V5 | VO |
| X | X | L | VO | VO |

NOTE 2. LCD Driving Voltage Application Circuit

(1) Segment driver application (CS = "Low")

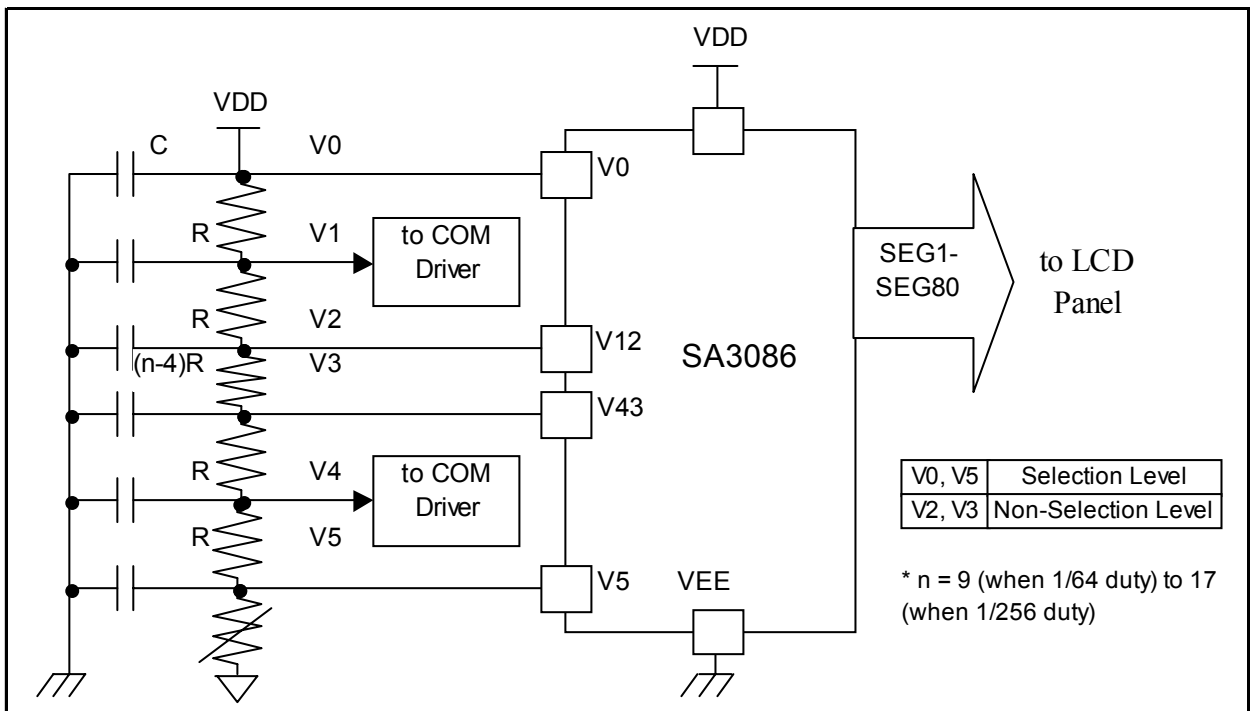

(2) Common driver application (CS= "High")

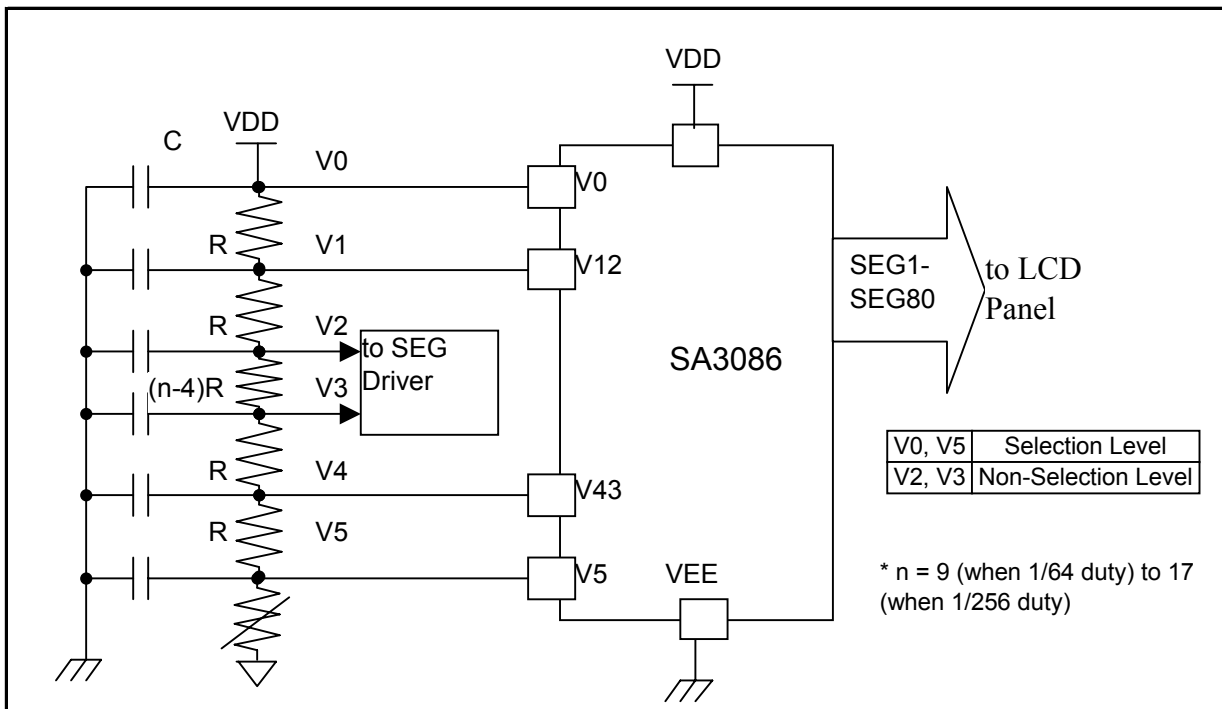

NOTE 3. Data Shift Direction according to Control Signals

(1) When CS = "Low" (segment driver application)

| AMS | SHL | Application mode | Data Direction | Input Pin |
|-----|-----|---|----------------|--------------------------------------|
| L | L | 4-Bit Parallel Data Transfer Mode (SEG) | | D1_SID, D2_DL, D3_DM, D4_DR |
| | H | | | D1_SID |
| H | L | 1-Bit Serial Data Transfer Mode (SEG) | | |
| | H | | | |

(2) When CS = "High" (common driver application)

| AMS | SHL | Application mode | Data Direction | Input Pin |
|-----|-----|------------------------------------|----------------|--------------|
| L | L | Single-type Application Mode (COM) | | D2_DL |
| | H | | | D4_DR |
| H | L | Dual-type Application Mode (COM) | | D2_DL, D3_DM |
| | H | | | D4_DR, D3_DM |

NOTE 4. Usage of Data Pins

| COM / SEG (CS pin) | Application mode (AMS pin) | SHL | Data interface pin | | | |
|-----------------------|---|-----|--------------------|----------------|-------------|--------------|
| | | | D1_SID | D2_DL | D3_DM | D4_DR |
| SEG (CS = "Low") | 4-bit parallel interface mode (AMS = "Low") | X | D1 (input) | D2 (input2) | D3 (input3) | D4 (input4) |
| | 1-bit serial interface mode (AMS = "Low") | X | SID (input) | Connect to VDD | | |
| COM (CS = "High") | single-type application mode (AMS = "Low") | L | open | DL (input) | Open | DR (output) |
| | | H | | DL (output) | | DR (input) |
| | dual-type application mode (AMS = "High") | L | open | DL (input1) | DM (input2) | DR (output2) |
| | | H | | DL (output2) | DM (input2) | DR (input1) |

MAXIMUM ABSOLUTE LIMIT

| Characteristic | Symbol | Value | Unit |
|-----------------------|-----------|-----------------------|------|
| Power supply voltage | V_{DD} | -0.3 - +7.0 | V |
| Driver supply voltage | V_{LCD} | 0 - +30 | |
| Input voltage | V_{IN} | -0.3 - $V_{DD} + 0.3$ | |
| Operating temperature | T_{opr} | -30 - +85 | °C |
| Storage temperature | T_{stg} | -55 - +150 | |

* **NOTE:** Voltage greater than above may do damage to the circuit.

ELECTRICAL CHARACTERISTICS

DC CHARACTERISTICS

(1) Segment Driver Application

($V_{SS} = 0V$, $T_a = -30 \sim +85^\circ C$)

| Characteristic | Symbol | Test Condition | Min. | Typ. | Max. | Unit | |
|-----------------------------|------------|--------------------------------------|---------------|------|-------------|-----------|---------|
| Operating Voltage1 | V_{DD} | - | 2.7 | - | 5.5 | V | |
| | V_{LCD} | $V_{IN} = V_{DD} - V_{EE}$ | 6 | - | 28 | | |
| Input voltage (1) | V_{IH} | - | $0.8V_{DD}$ | - | V_{DD} | V | |
| | V_{IL} | - | 0 | - | $0.2V_{DD}$ | | |
| Output voltage (2) | V_{OH} | $I_{OH} = -0.4mA$ | $V_{DD}-0.4$ | - | - | V | |
| | V_{OL} | $I_{OL} = 0.4mA$ | - | - | 0.4 | | |
| Input leakage current 1 (1) | I_{IL1} | $V_{IN} = V_{DD} \text{ to } V_{SS}$ | -10 | - | 10 | μA | |
| Input leakage current 2 (3) | I_{IL2} | $V_{IN} = V_{DD} \text{ to } V_{EE}$ | -25 | - | 25 | | |
| On resistance (4) | R_{ON} | $I_{ON} = 100\mu A$ | - | 2 | 4 | $k\Omega$ | |
| Supply current (5) | I_{STBY} | $f_{CL1} = 32kHz$ $M = V_{SS}$ | V_{SS} pin | - | - | 100 | μA |
| | I_{DD} | $f_{CL1} = 32kHz$ $f_M = 80 Hz$ | $V_{DD} = 5V$ | - | - | 5 | mA |
| | | | $V_{DD} = 3V$ | - | - | 2 | |
| I_{EE} | | $V_{DD} = 5V$ | - | - | 500 | μA | |

NOTES:

- Applied to CL1, CL2, ELB, ERB, D1_SID – D4_DR, SHL, DISPOFFB, M, CS, AMS pin
- ELB, ERB pin
- V0, V12, V43, V5 pin
- $V_{LCD} = V_{DD} - V_{EE}$, $V0 = V_{DD} = 5V$, $5V = V_{EE} = -23V$
 $V12 = V_{DD} - 2/n(V_{LCD})$, $V43 = V_{EE} + 2/n(V_{LCD})$, $n = 17$ (1/256 duty, 1/17 bias)
- $V0 = V_{DD}$, $V12 = 1.71V(V_{DD} = 5V)$ or $-0.06V(V_{DD} = 3V)$,
 $V43 = -19.71V(V_{DD} = 5V)$ or $-19.94V(V_{DD} = 3V)$, $V5 = V_{EE} = -23V$, no-load condition (1/256 duty, 1/17 bias)
 4-bit parallel interface mode
 I_{STBY} : $V_{DD} = 5V$, $f_{CL2} = 5.12MHz$, $SHL = V_{SS}$, $DISPOFFB = V_{DD}$, $M = V_{SS}$, display data pattern = 0000
 I_{DD} : $V_{DD} = 3V$, $f_{CL2} = 4MHz$, display data pattern = 0101
 $V_{DD} = 5V$, $f_{CL2} = 5.12MHz$, display data pattern = 0101
 I_{EE} : $V_{DD} = 5V$, $f_{CL2} = 5.12MHz$, display data pattern = 0101, V_{EE} pin

DC CHARACTERISTICS (CONTINUED)

(2) Common Driver Application

(V_{SS} = 0V, Ta = -30 - +85°C)

| Characteristic | Symbol | Test Condition | Min. | Typ. | Max. | Unit | |
|-----------------------------|-------------------|--|----------------------|------|--------------------|------|----|
| Operating Voltage1 | V _{DD} | - | 2.7 | - | 5.5 | V | |
| | V _{LCD} | V _{IN} = V _{DD} - V _{EE} | 6 | - | 28 | | |
| Input voltage (1) | V _{IH} | - | 0.8V _{DD} | - | V _{DD} | V | |
| | V _{IL} | - | 0 | - | 0.2V _{DD} | | |
| Output voltage (3) | V _{OH} | I _{OH} = -0.4mA | V _{DD} -0.4 | - | - | V | |
| | V _{OL} | I _{OL} = 0.4Ma | - | - | 0.4 | | |
| Input leakage current 1 (1) | I _{IL1} | V _{IN} = V _{DD} to V _{SS} | -10 | - | 10 | μA | |
| Input leakage current 2 (2) | I _{IL2} | V _{IN} = 0V, V _{DD} = 5V (PULL UP) | -50 | -125 | -250 | | |
| Input leakage current 3 (4) | I _{IL3} | V _{IN} = V _{DD} to V _{SS} | -25 | - | 25 | | |
| On resistance (5) | R _{ON} | I _{ON} = 100μA | - | 2 | 4 | kΩ | |
| Supply current (6) | I _{STBY} | f _{CL1} = 32kHz | V _{ss} pin | - | - | 100 | μA |
| | I _{DD} | f _{CL1} = 32kHz f _M = 80 Hz | V _{DD} = 5V | - | - | 200 | |
| | | | V _{DD} = 3V | - | - | 120 | |
| | | | V _{DD} = 5V | - | - | 150 | |

NOTES:

- Applied to CL1, D2_DL (SHL = LOW), D4_DR (SHL = HIGH), SHL, DISPOFFB, M, CS, AMS pin
- Pull-up input pins : CL2, D1_SID, D3_DM (AMS = HIGH), ELB (SHL = LOW), ERB (SHL = HIGH)
- D2_DL (SHL = HIGH) , D4_DR (SHL = LOW) pin
- V0, V12, V43, V5 pin
- V_{KCD} = V_{DD}-V_{EE}, V0 = V_{DD} = 5V, V5 = V_{EE} = -23V
V12 = V_{DD}-1/n(V_{LCD}), V43 = V_{EE}+1/n(V_{LCD}), n = 17(1/256 duty, 1/17 bias)
- V0 = V_{DD}, V12 = 3.35V (V_{DD} = 5V) or 1.47V (V_{DD} = 3V),
V43 = -21.35V (V_{DD} = 5 V) or -21.47V (V_{DD} = 3 V), V5 = V_{EE} = -23 V, no-load condition (1/256 duty, 1/17 bias)
single-type mode operation : AMS = V_{SS}, SHL = V_{SS}, DISPOFFB = V_{DD}
D1_SID = D3_DM = V_{DD}, D4_DR = OPEN, ELB = ERB = OPEN,
I_{STBY} : V_{DD} = 5V, M = V_{SS}, D2_DL = V_{SS}
I_{DD} : f_M = 80Hz, D2_DL = V_{DD}
V_{DD} = 3 V, display data pattern = 10000000..., 01000000..., 00100000..., 00010000..., ..
V_{DD} = 5 V, display data pattern = 10000000..., 01000000..., 00100000..., 00010000..., ..
I_{EE} : f_M = 80Hz, D2_DL = V_{DD}
V_{DD} = 5V, current through V_{EE} Pin, display data pattern = 10000000..., 01000000...,
00100000..., 00010000...

AC CHARACTERISTICS

(1) Segment Driver Application

(V_{SS} = 0V, T_a = - 30 - +85°C)

| Characteristic | Symbol | Test Condition | (1) V _{DD} = 5V ± 10% | | | (2) V _{DD} = 3V ± 10% | | | Unit |
|---------------------------------------|--------------------------------|-----------------------|--------------------------------|------|------|--------------------------------|------|------|------|
| | | | Min. | Typ. | Max. | Min. | Typ. | Max. | |
| Clock cycle time | t _{CY} | Duty = 50% | 125 | - | - | 250 | - | - | Ns |
| Clock pulse width | t _{WCK} | - | 45 | - | - | 95 | - | - | |
| Clock rise / fall time | t _R /t _F | - | - | - | - | - | - | 30 | |
| Data set-up time | t _{DS} | - | 30 | - | - | 65 | - | - | |
| Data hold time | t _{DH} | - | 30 | - | - | 65 | - | - | |
| Clock set-up time | t _{CS} | - | 80 | - | - | 120 | - | - | |
| Clock hold time | t _{CH} | - | 80 | - | - | 120 | - | - | |
| Propagation delay time | t _{PHL} | ELB Output | - | - | 60 | - | - | 125 | |
| | | ERB Output | - | - | 60 | - | - | 125 | |
| ELB, ERB set-up time | t _{PUS} | ELB Input | 30 | - | - | 65 | - | - | |
| | | ERB Input | 30 | - | - | 65 | - | - | |
| DISPOFFB low pulse width | t _{WDL} | - | 1.2 | - | - | 1.2 | - | - | μs |
| DISPOFFB clear time | t _{CD} | - | 100 | - | - | 100 | - | - | Ns |
| M – OUT propagation delay time | t _{PD1} | C _L = 15pF | - | - | 1.0 | - | - | 1.2 | μs |
| CL1 – OUT propagation delay time | t _{PD2} | | - | - | 1.0 | - | - | 1.2 | |
| DISPOFFB – OUT propagation delay time | t _{PD3} | | - | - | 1.0 | - | - | -s | |

AC CHARACTERISTICS (CONTINUED)

(2) Common Driver Application

(V_{SS} = 0V, T_a = - 30 - +85°C)

| Characteristic | Symbol | Test Condition | (1) V _{DD} = 5V ± 10% | | | (2) V _{DD} = 3V ± 10% | | | Unit |
|---------------------------------------|--------------------------------|-----------------------|--------------------------------|------|------|--------------------------------|------|------|------|
| | | | Min. | Typ. | Max. | Min. | Typ. | Max. | |
| Clock cycle time | t _{CY} | Duty = 50% | 250 | - | - | 500 | - | - | ns |
| Clock pulse width | t _{WCK} | - | 45 | - | - | 95 | - | - | |
| Clock rise / fall time | t _R /t _F | - | - | - | 50 | - | - | 50 | |
| Data set-up time | t _{DS} | - | 30 | - | - | 65 | - | - | |
| Data hold time | t _{DH} | - | 30 | - | - | 65 | - | - | |
| DISPOFFB low pulse width | t _{WDL} | - | 1.2 | - | - | 1.2 | - | - | μs |
| DISPOFFB clear time | t _{CD} | - | 100 | - | - | 100 | - | - | ns |
| Output delay time | t _{DL} | C _L = 15pF | - | - | 200 | - | - | 250 | μs |
| M – OUT propagation delay time | t _{PD1} | | - | - | 1.0 | - | - | 1.2 | |
| CL1 – OUT propagation delay time | t _{PD2} | | - | - | 1.0 | - | - | 1.2 | |
| DISPOFFB – OUT propagation delay time | t _{PD3} | | - | - | 1.0 | - | - | 1.2 | |

AC CHARACTERISTICS (CONTINUED)

(3) Segment Driver Application Timing

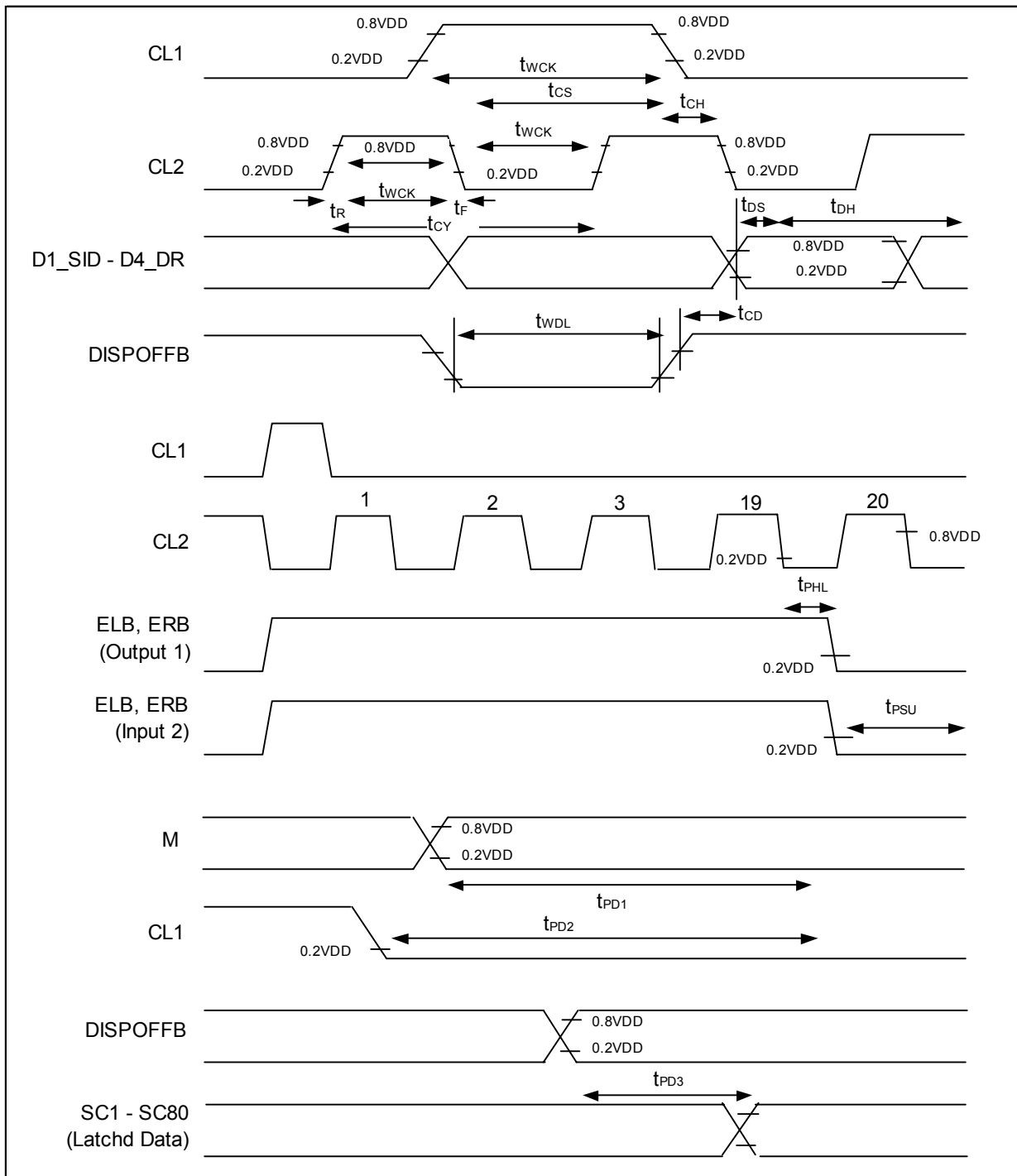

AC CHARACTERISTICS (CONTINUED)

(4) Common Driver Application Timing

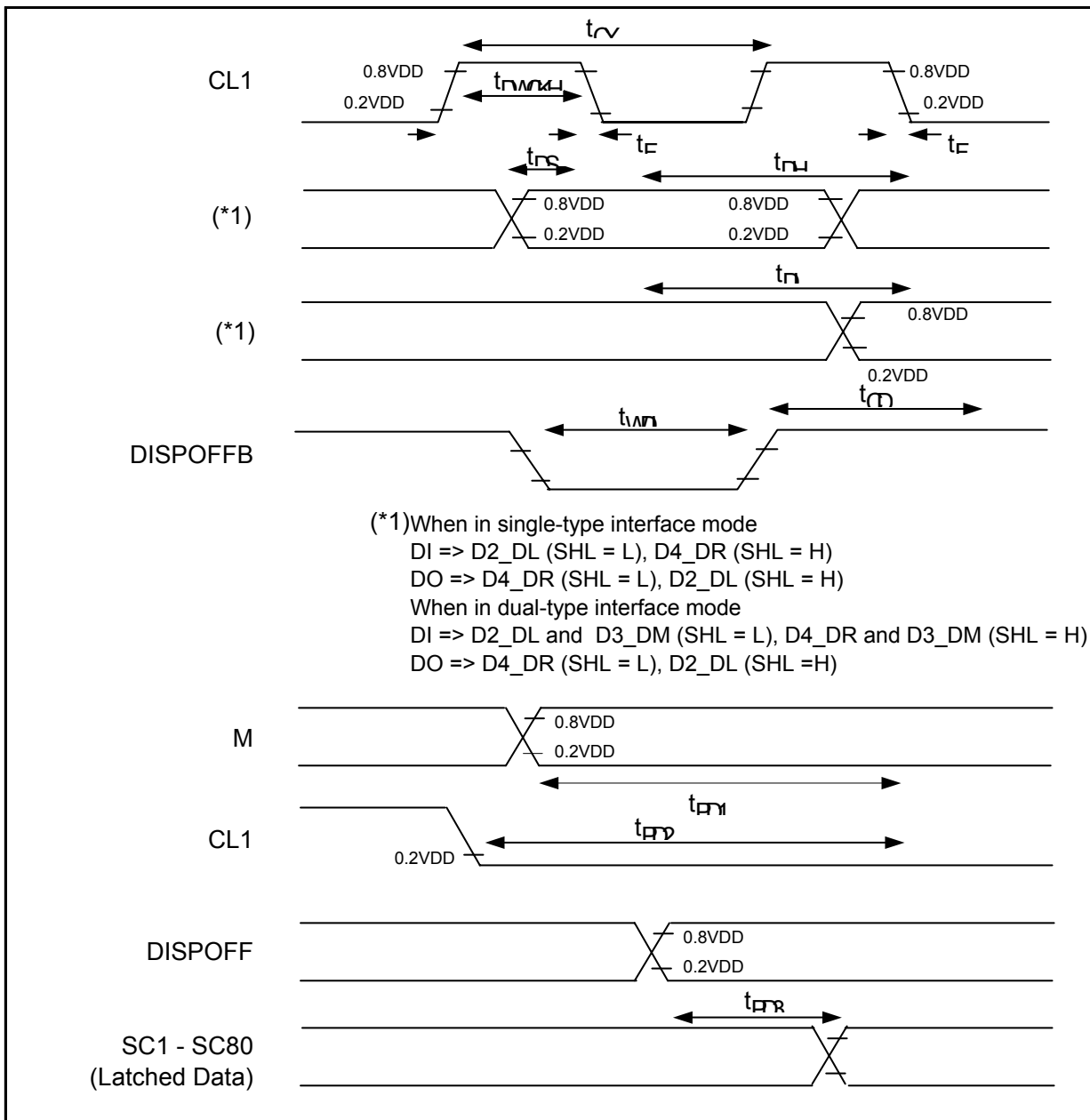

POWER DOWN FUNCTION

In the case of cascade connection of segment mode drivers, S6B0086 has a “power down function” in order to reduce the power consumption.

| SHL | Enable input | Enable output | Current driver status | The other drivers status |
|-----|--------------|---------------|--|--------------------------|
| L | ERB | ELB | While ERB =”Low”, current driver is enabled. | Disabled |
| H | ELB | ERB | While ELB =”Low”, current driver is enabled. | Disabled |

* In the case of common driver application, power down function does not work.

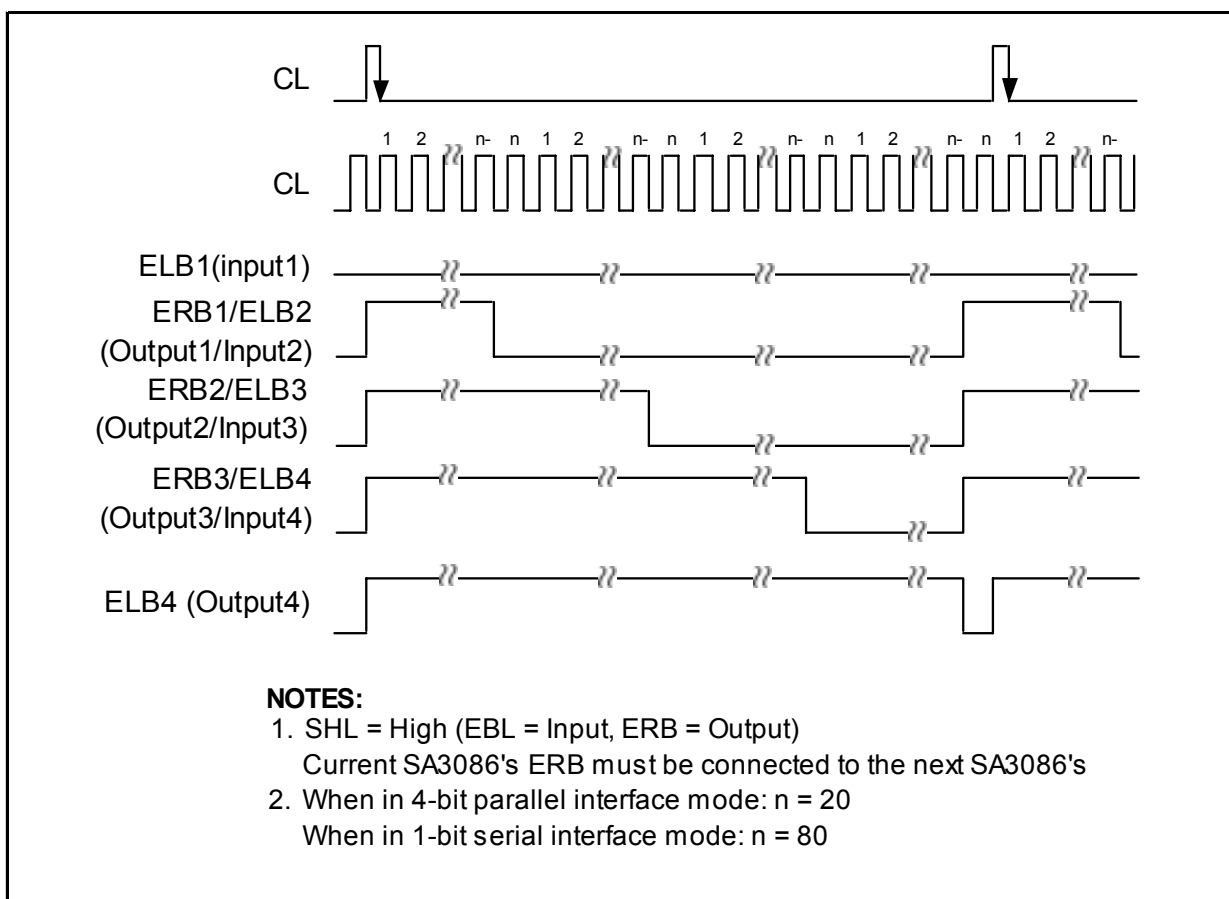

OPERATION TIMING DIAGRAM

(1) 4-BIT Parallel Mode Interface Segment Driver

- When SHL = "Low"

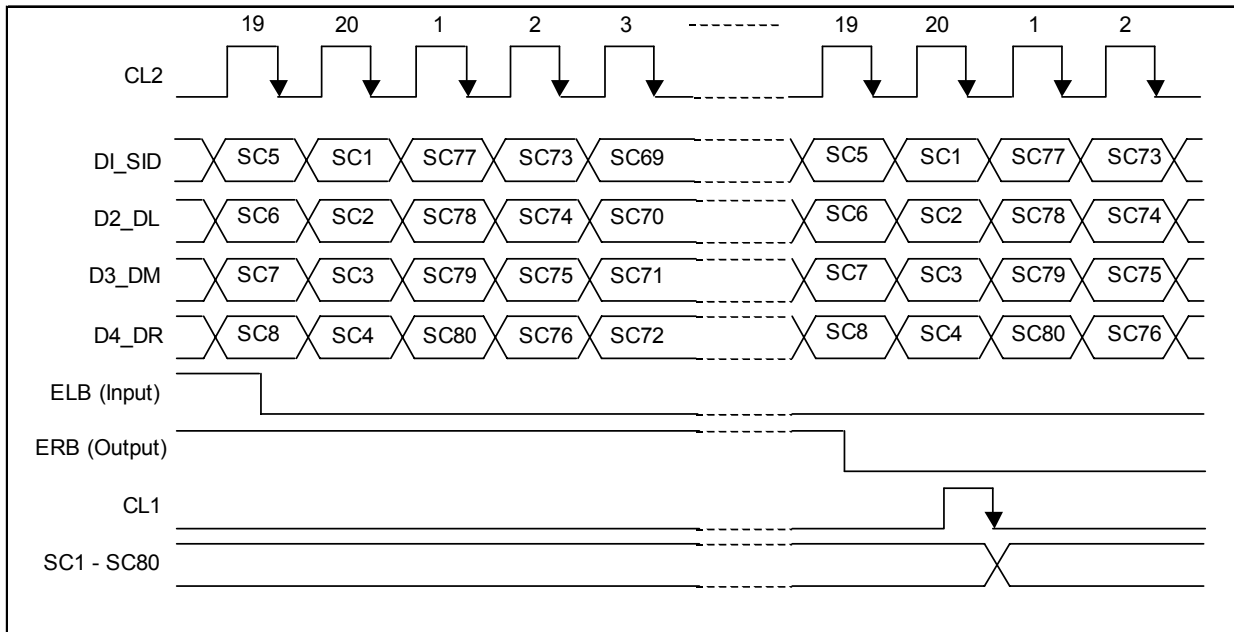

- When SHL = "High"

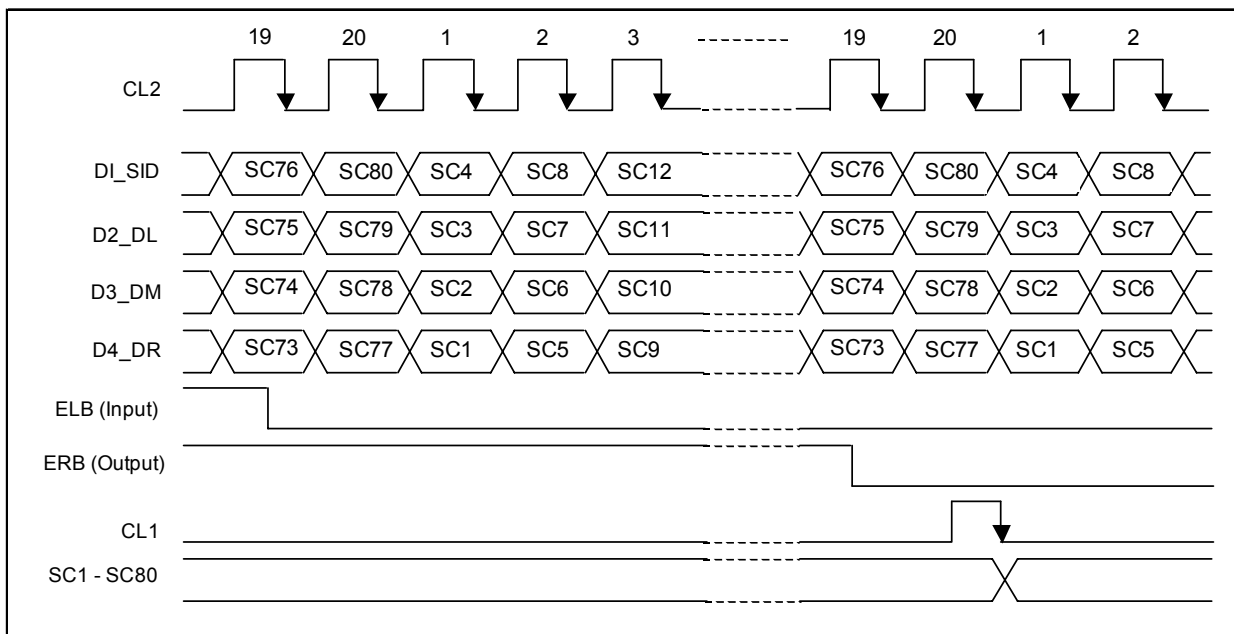

(2) 1-bit Serial Mode Interface Segment Driver

- When SHL = "Low"

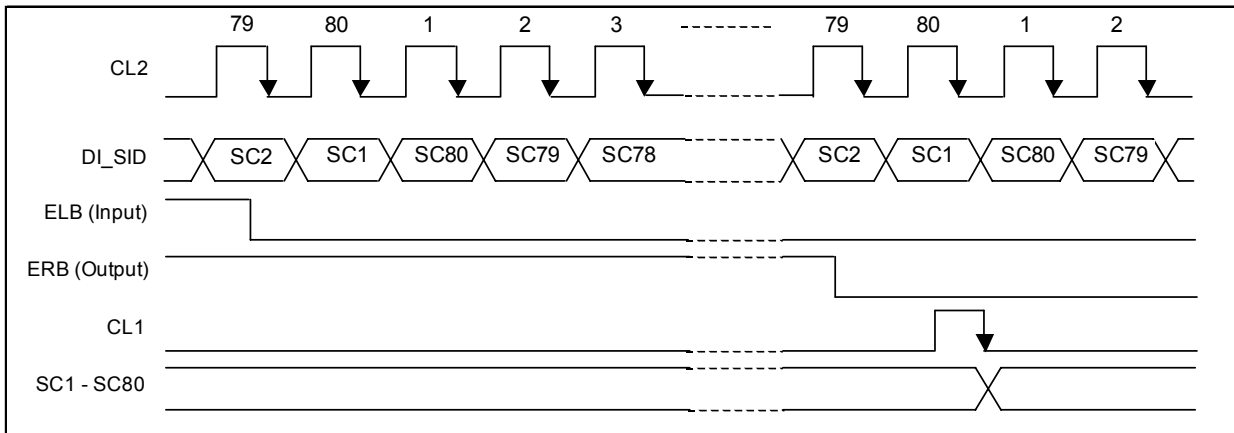

- When SHL = "High"

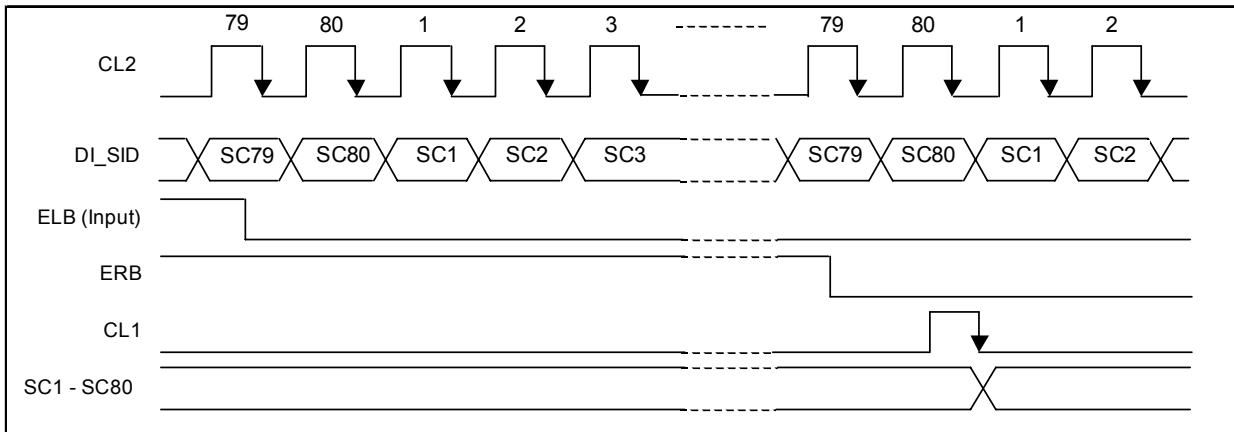

(3) Single-type Interface Mode Common Driver

- When SHL = "Low"

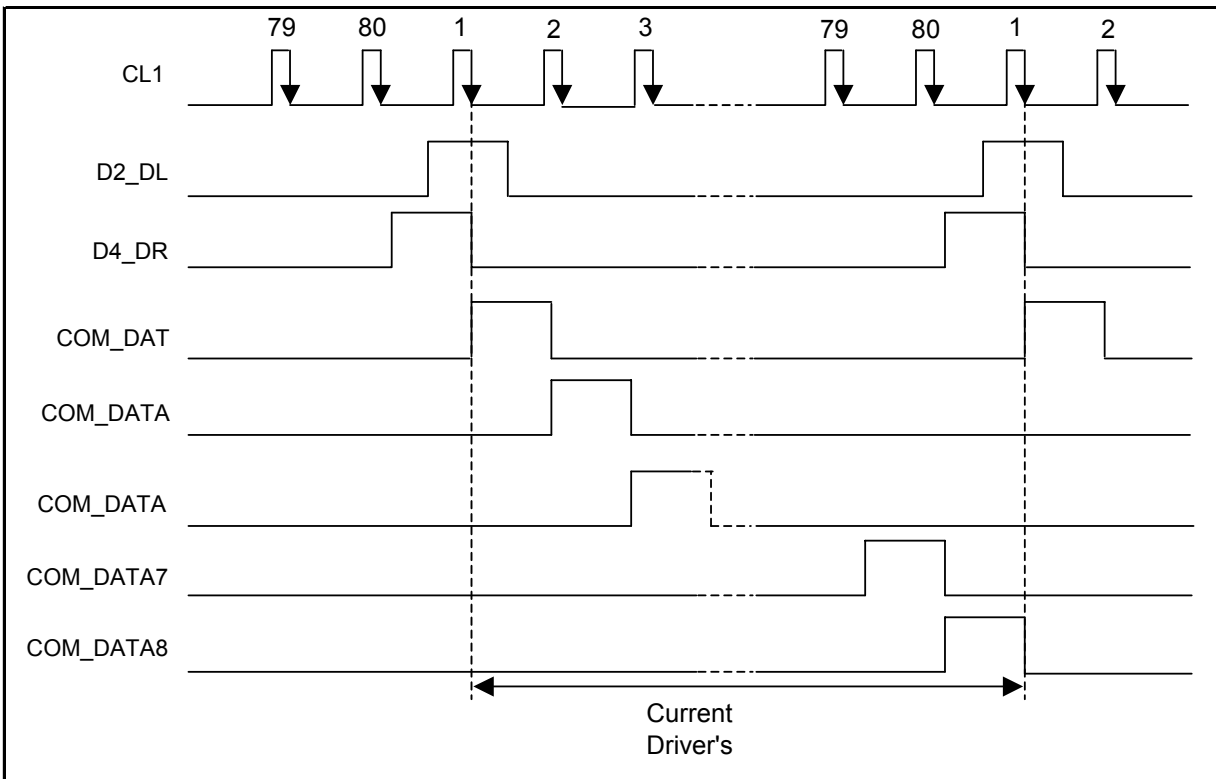

- When SHL = "High"

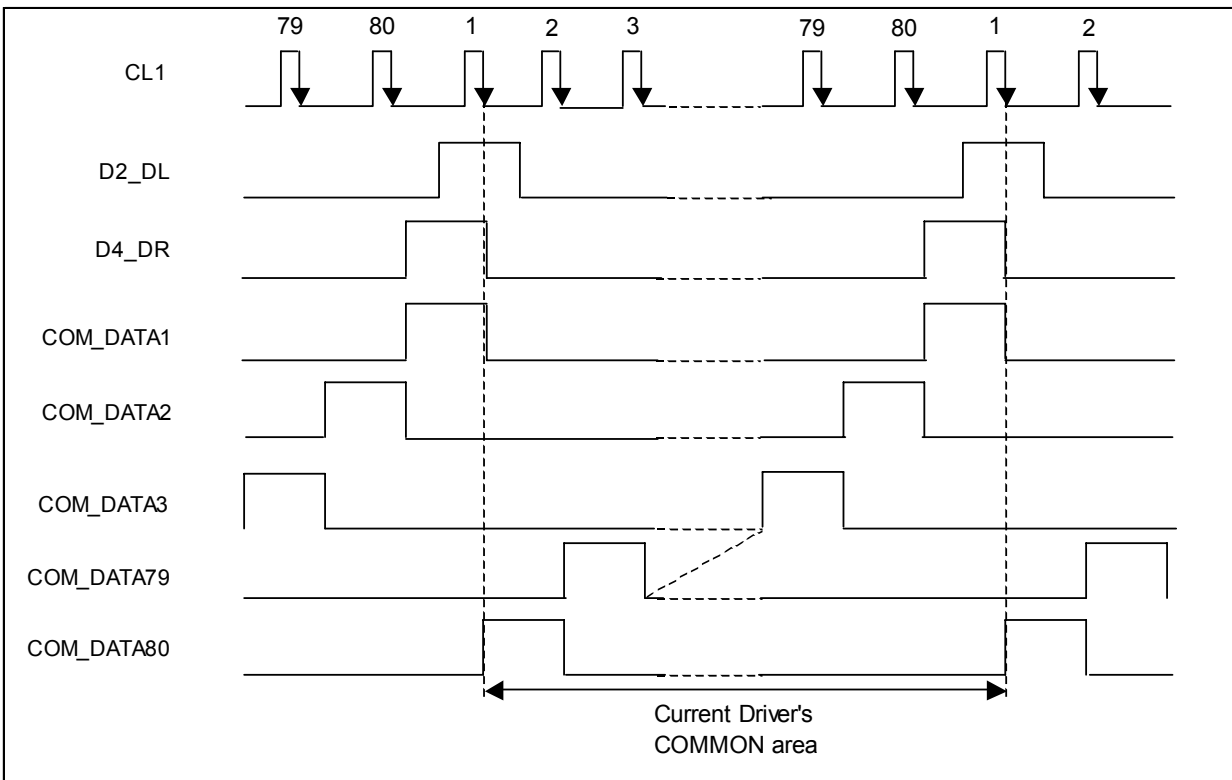

(4) Dual type interface mode driver

- When SHL = "Low"

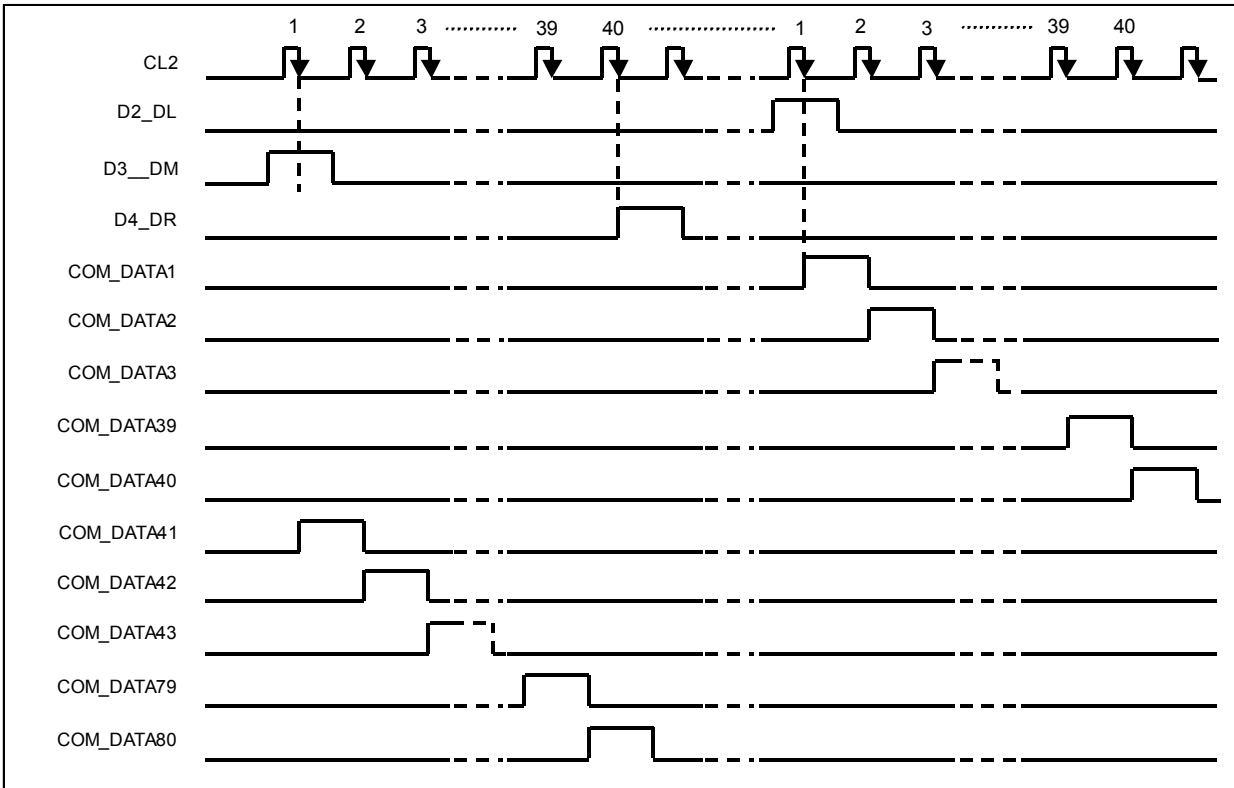

- When SHL = "High"

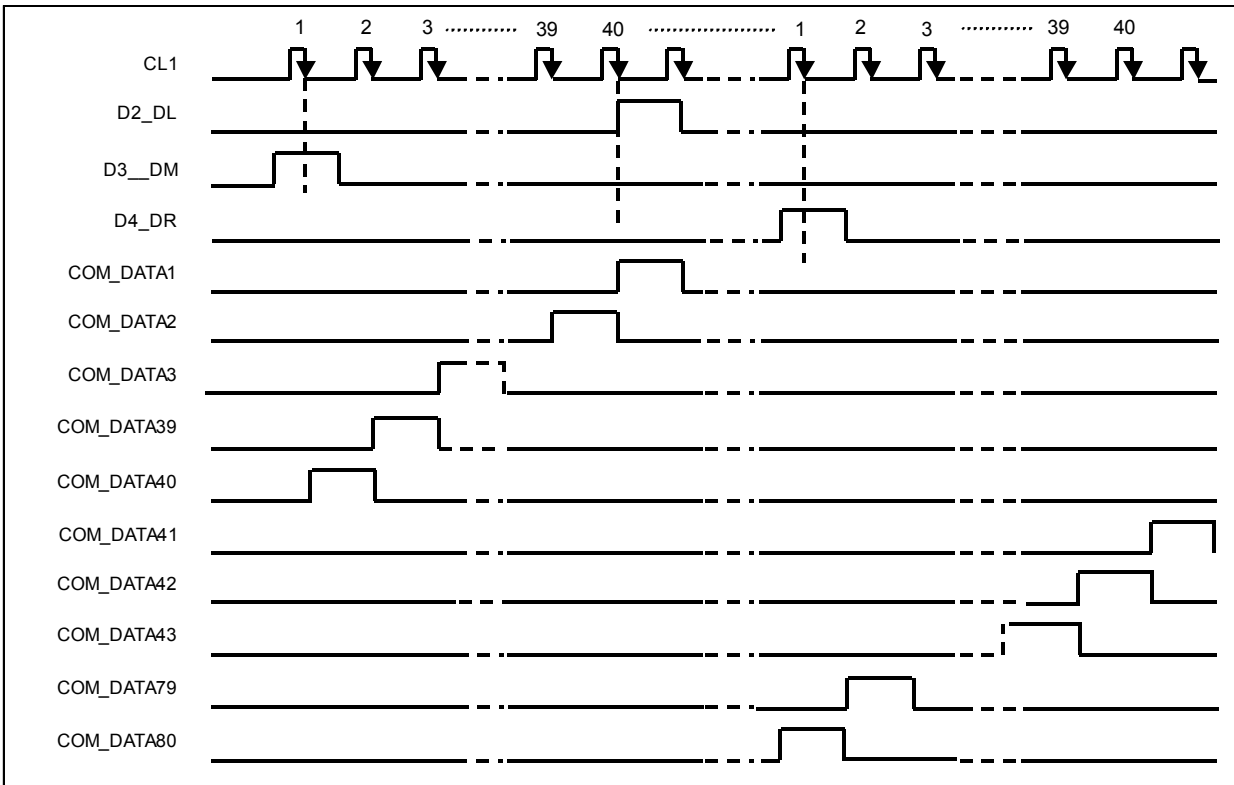

(5) Common / Segment Driver Timing (1/200 DUTY)

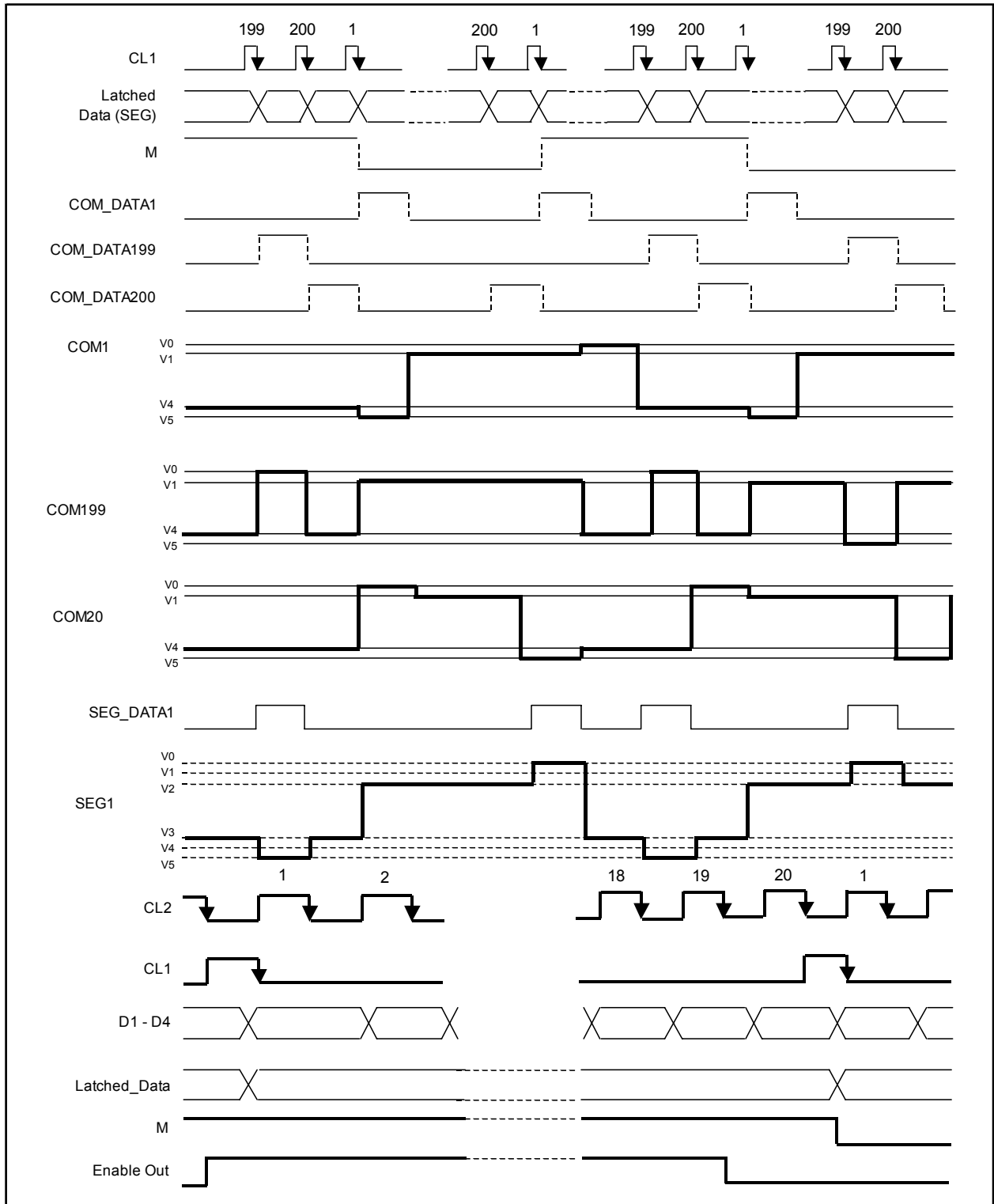

APPLICATION INFORMATION

1-bit Serial Interface (80-Ch. Segment Driver)

a) Lower View (SHL = L, AMS = H)

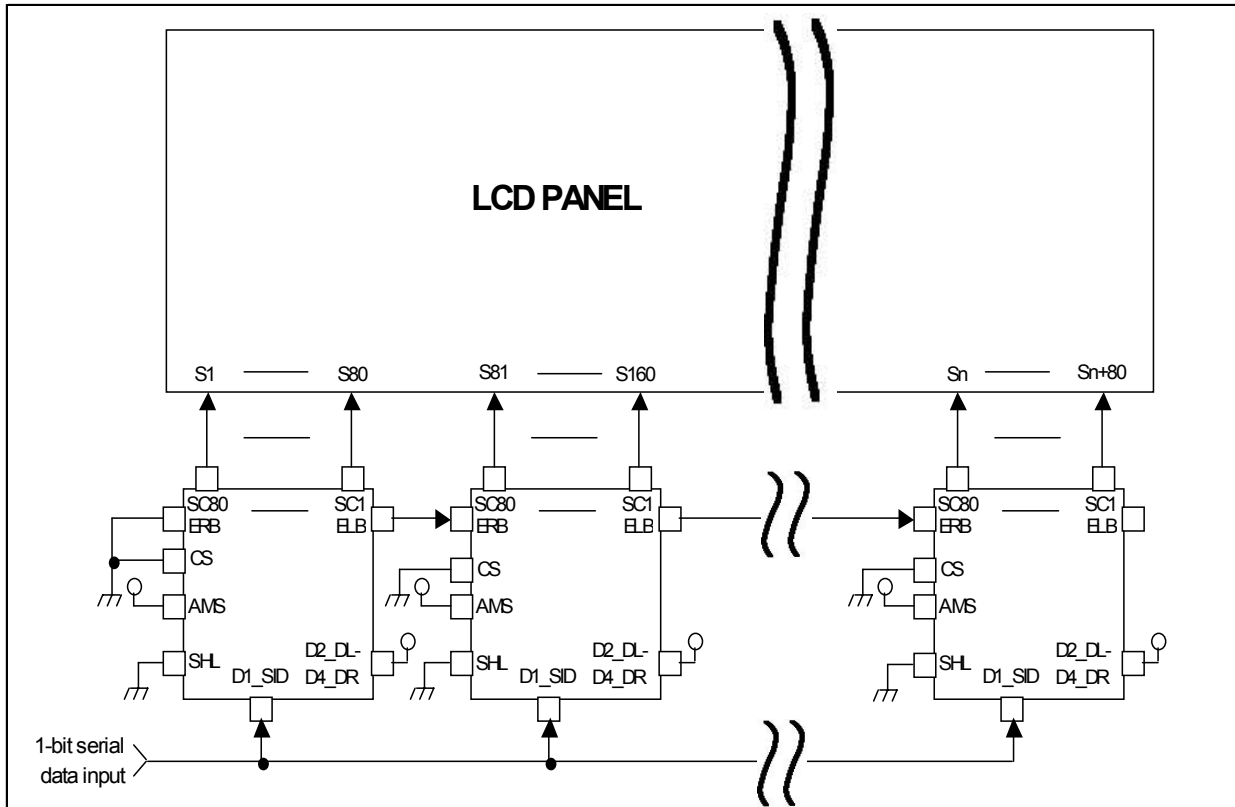

b) Upper View (SHL = H, AMS = H)

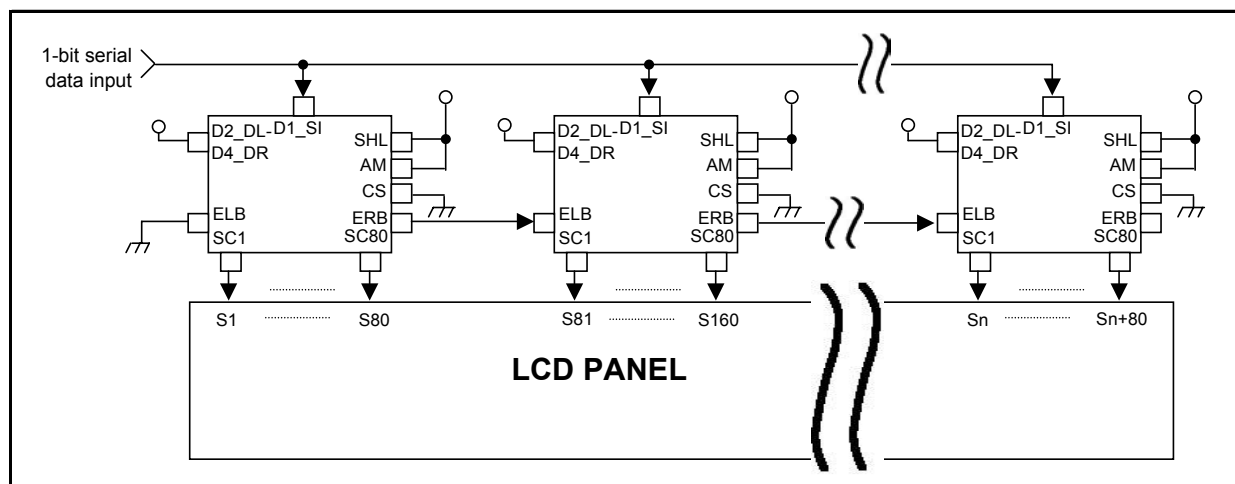

4-Bit Parallel Interface Mode (80 Ch. Segment Driver)

a) Lower View (SHL = L, AMS = L)

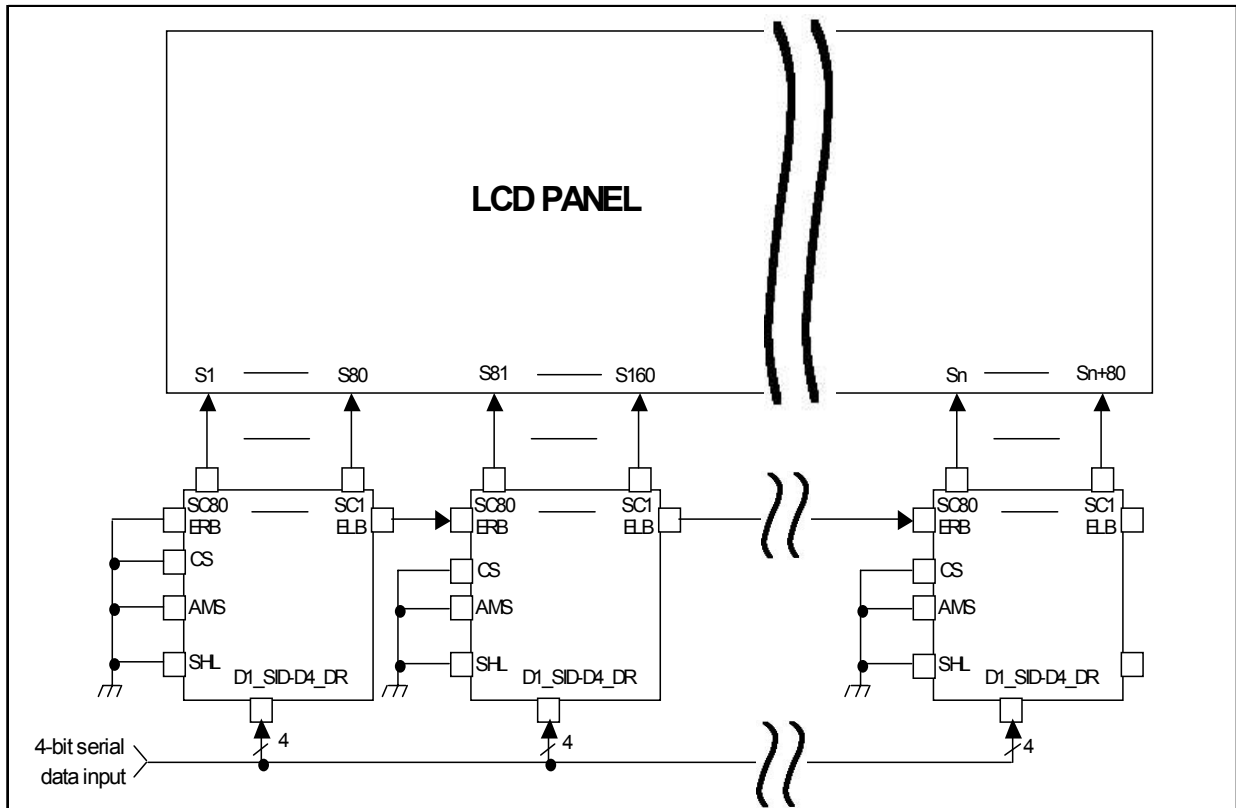

b) Upper View (SHL = H, AMS = L)

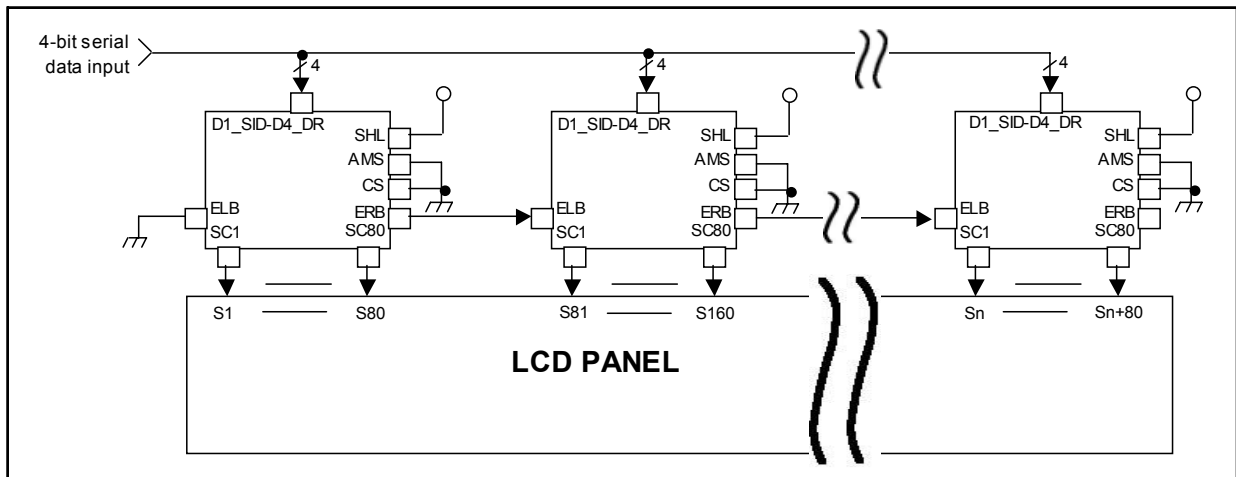

Single-type Interface Mode (80 Ch. Common Driver)

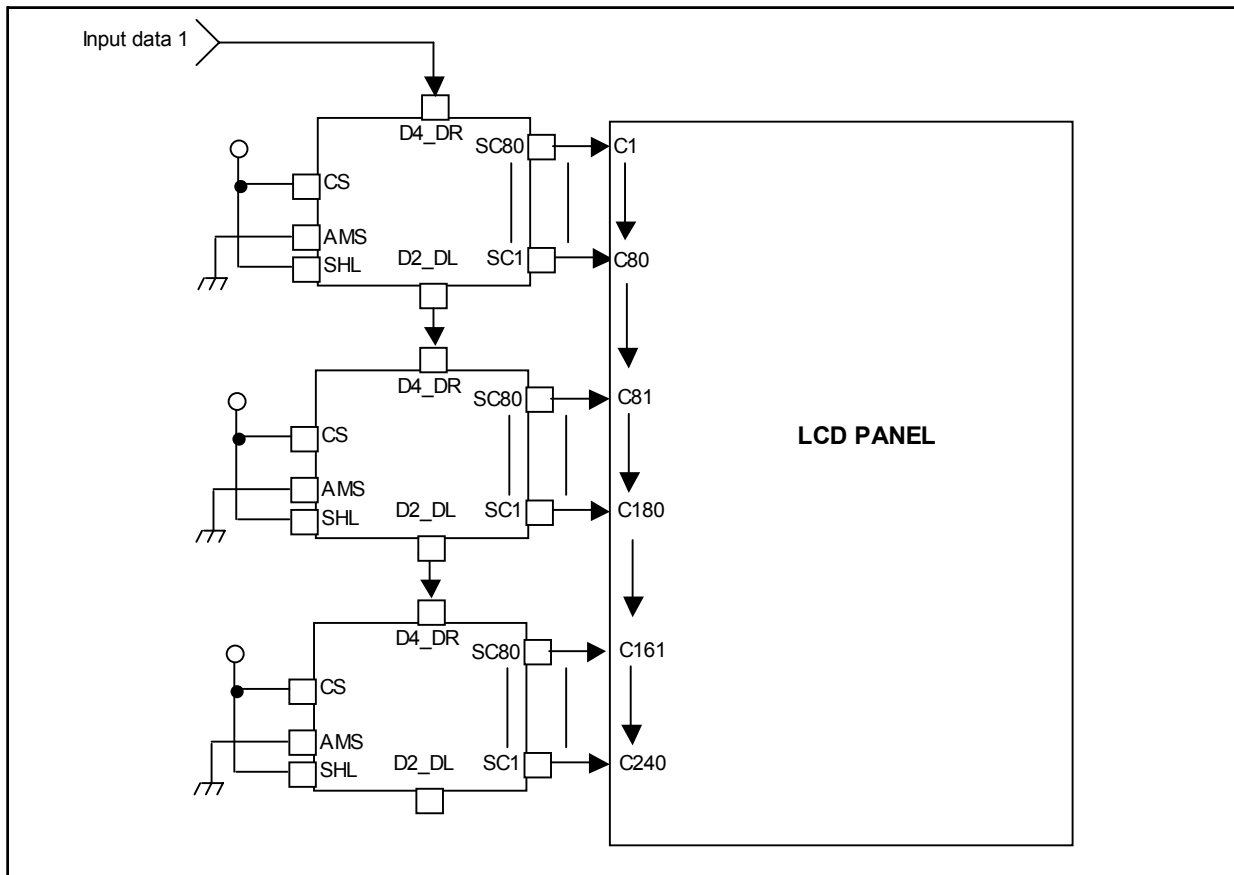

Dual-type Interface Mode (40 Ch. Common Driver)

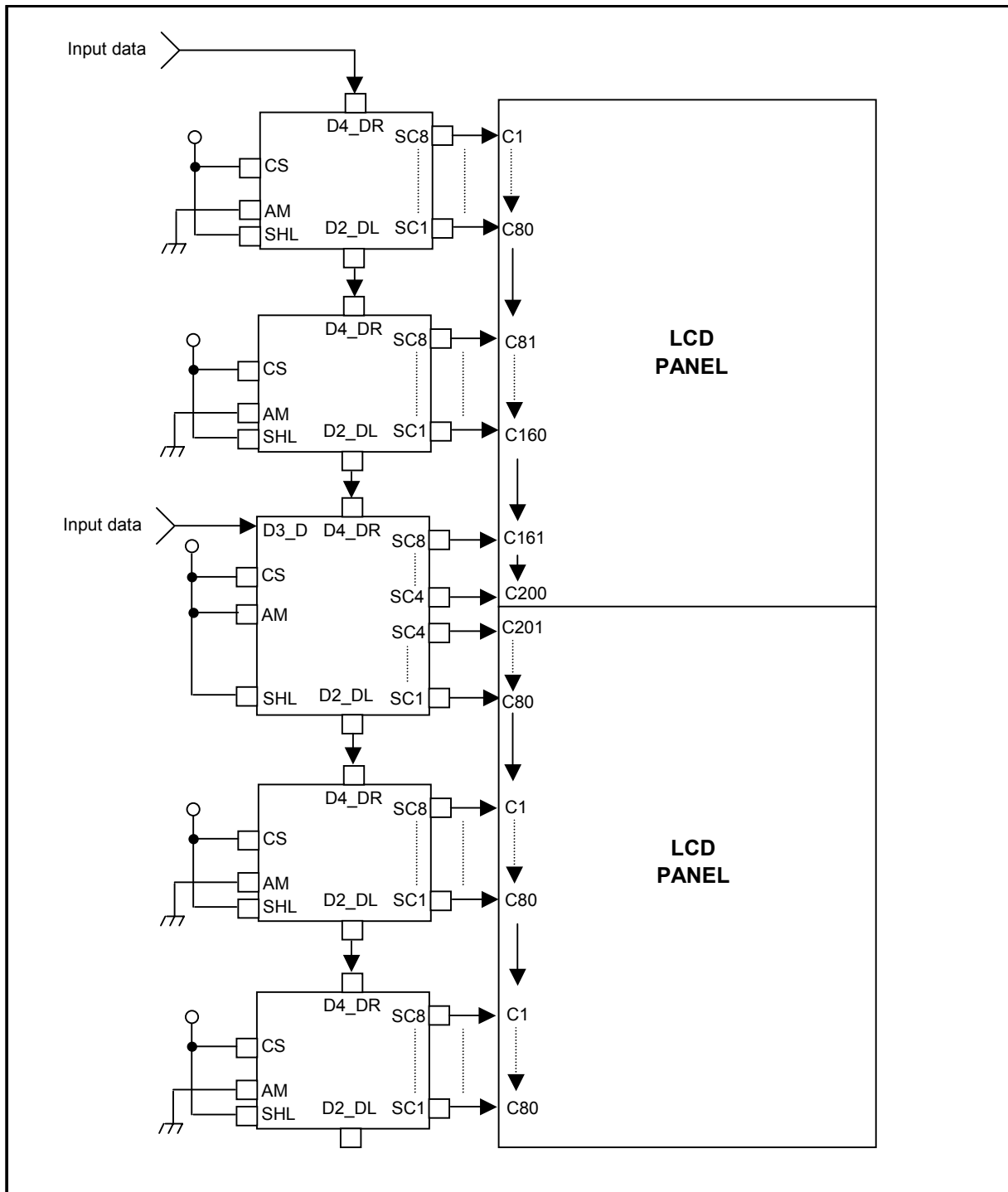

NOTE: Using this application mode (dual-type common mode), the duty ratio can be reduced to half, In case, 1/200 duty can be used to drive the 400 common LCD panel.

APPLICATION CIRCUIT EXAMPLE

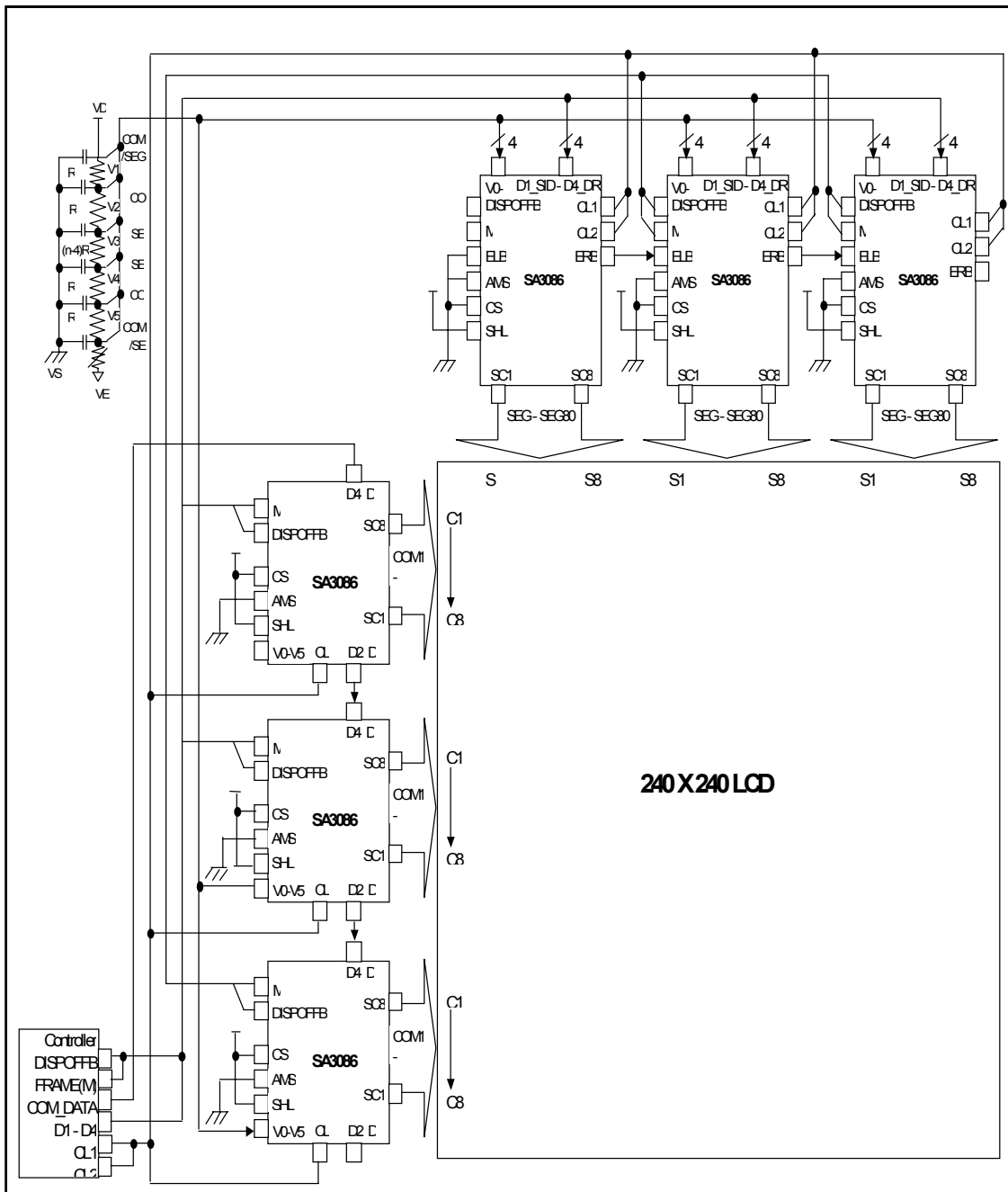

With collaboration of <https://www.displayfuture.com>