

S6B0107

64CH COMMON DRIVER FOR DOT MATRIX LCD

July 2001

Ver. 0.0

Contents in this document are subject to change without notice. No part of this document may be reproduced or transmitted in any form or by any means, electronic or mechanical, for any purpose, without the express written permission of LCD Driver IC Team.

Precautions for Light

Light has characteristics to move electrons in the integrated circuitry of semiconductors, therefore may change the characteristics of semiconductor devices when irradiated with light. Consequently, the users of the packages which may expose chips to external light such as COB, COG, TCP and COF must consider effective methods to block out light from reaching the IC on all parts of the surface area, the top, bottom and the sides of the chip. Follow the precautions below when using the products.

1. Consider and verify the protection of penetrating light to the IC at substrate (board or glass) or product design stage.
2. Always test and inspect products under the environment with no penetration of light.

S6B0107 Specification Revision History		
Version	Content	Date
0.0	Original	July.2001

CONTENTS

INTRODUCTION	1
BLOCK DIAGRAM	2
PIN CONFIGURATION	3
100-QFP.....	3
PAD DIAGRAM (CHIP LAYOUT FOR THE 100QFP).....	4
PAD CENTER COORDINATES (100QFP).....	5
100-TQFP (S6B2107).....	6
PAD DIAGRAM (CHIP LAYOUT FOR THE 100-TQFP).....	7
PAD CENTER COORDINATES (100-TQFP).....	8
PIN DESCRIPTION	10
ELECTRICAL CHARACTERISTICS	13
DC CHARACTERISTICS	13
AC CHARACTERISTICS ($V_{DD} = 5V \pm 10\%$, $T_A = -30^{\circ}C$ to $+85^{\circ}C$).....	14
FUNCTIONAL DESCRIPTION	17
TIMING DIAGRAM	19
1/48 DUTY TIMING (MASTER MODE).....	19
1/128 DUTY TIMING (MASTER MODE).....	20
1/48 DUTY TIMING (SLAVE MODE).....	21
POWER DRIVER CIRCUIT.....	22
APPLICATION CIRCUIT	23

INTRODUCTION

The S6B0107 (TQFP type: S6B2107) is a LCD driver LSI with 64 channel outputs for dot matrix liquid crystal graphic display systems. This device provides 64 shift registers and 64 output drivers. It generates the timing signal to control the S6B0108 (64 channel segment driver - TQFP type: S6B2108). The S6B0107 is fabricated by low power CMOS high voltage process technology, and is composed of the liquid crystal display system in combination with the S6B0108 (64 channel segment driver).

FEATURES

- Dot matrix LCD common driver with 64 channel output
- 64-bit shift register at internal LCD driver circuit
- Internal timing generator circuit for dynamic display
- Selection of master/slave mode
- Applicable LCD duty: 1/48, 1/64, 1/96, 1/128
- Power supply voltage: + 5V \pm 10%
- LCD driving voltage: 8V - 17V ($V_{DD}-V_{EE}$)
- Interface

Driver		Controller
COMMON	SEGMENT	
Other S6B0107	S6B0108	MPU

- High voltage CMOS process
- 100QFP/100TQFP and bare chip available

BLOCK DIAGRAM

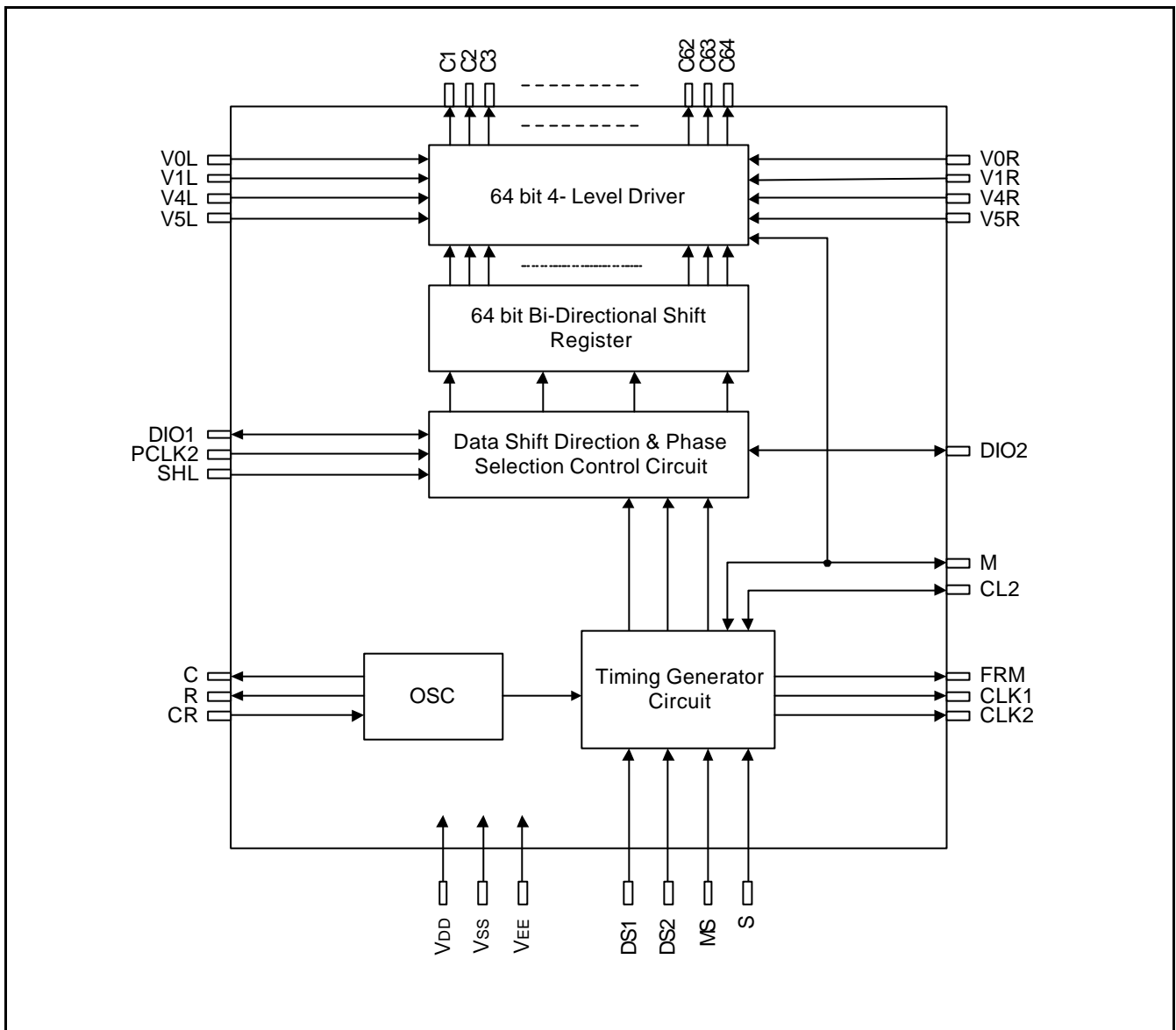

PIN CONFIGURATION

100-QFP

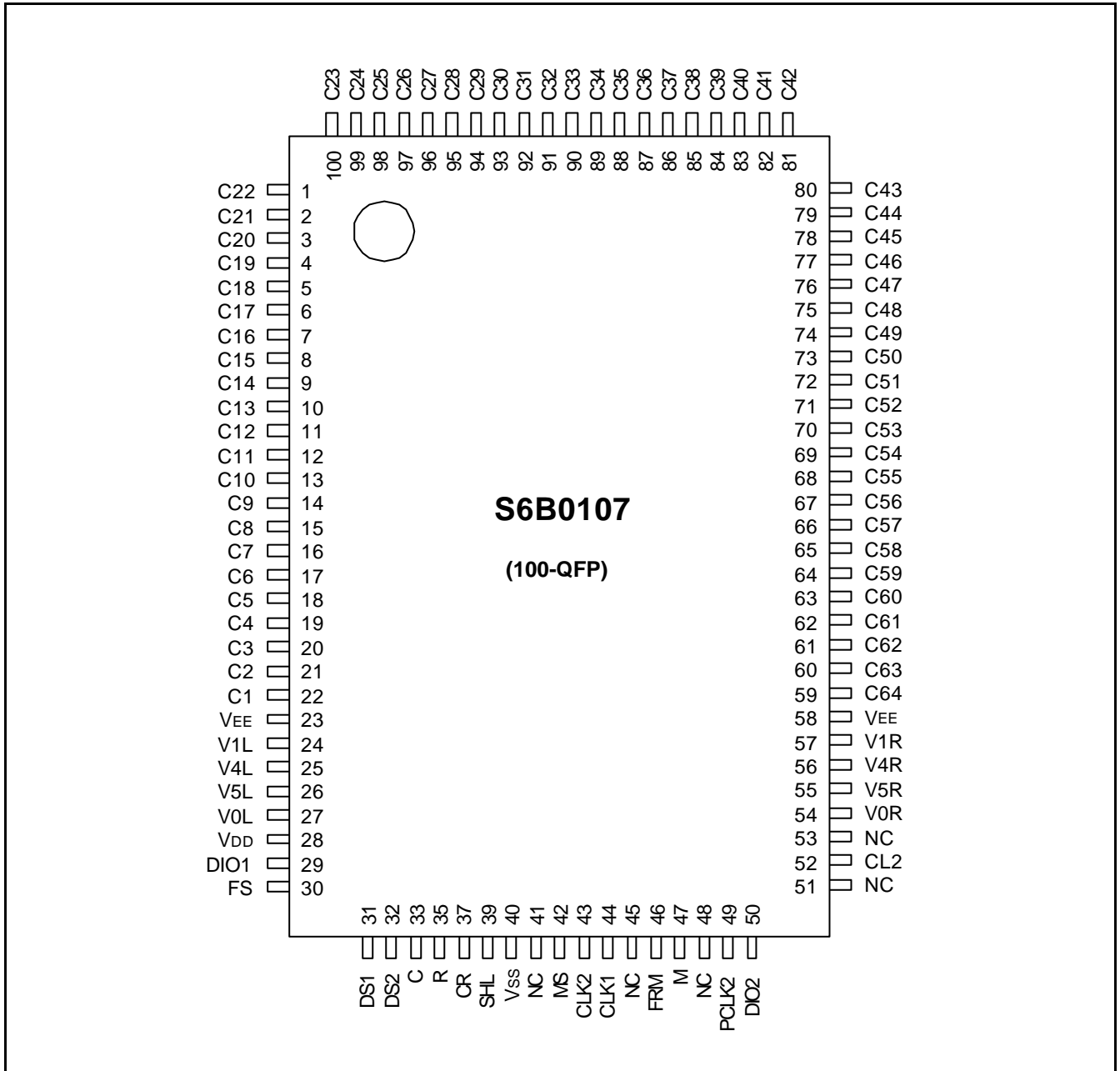

PAD DIAGRAM (CHIP LAYOUT FOR THE 100QFP)

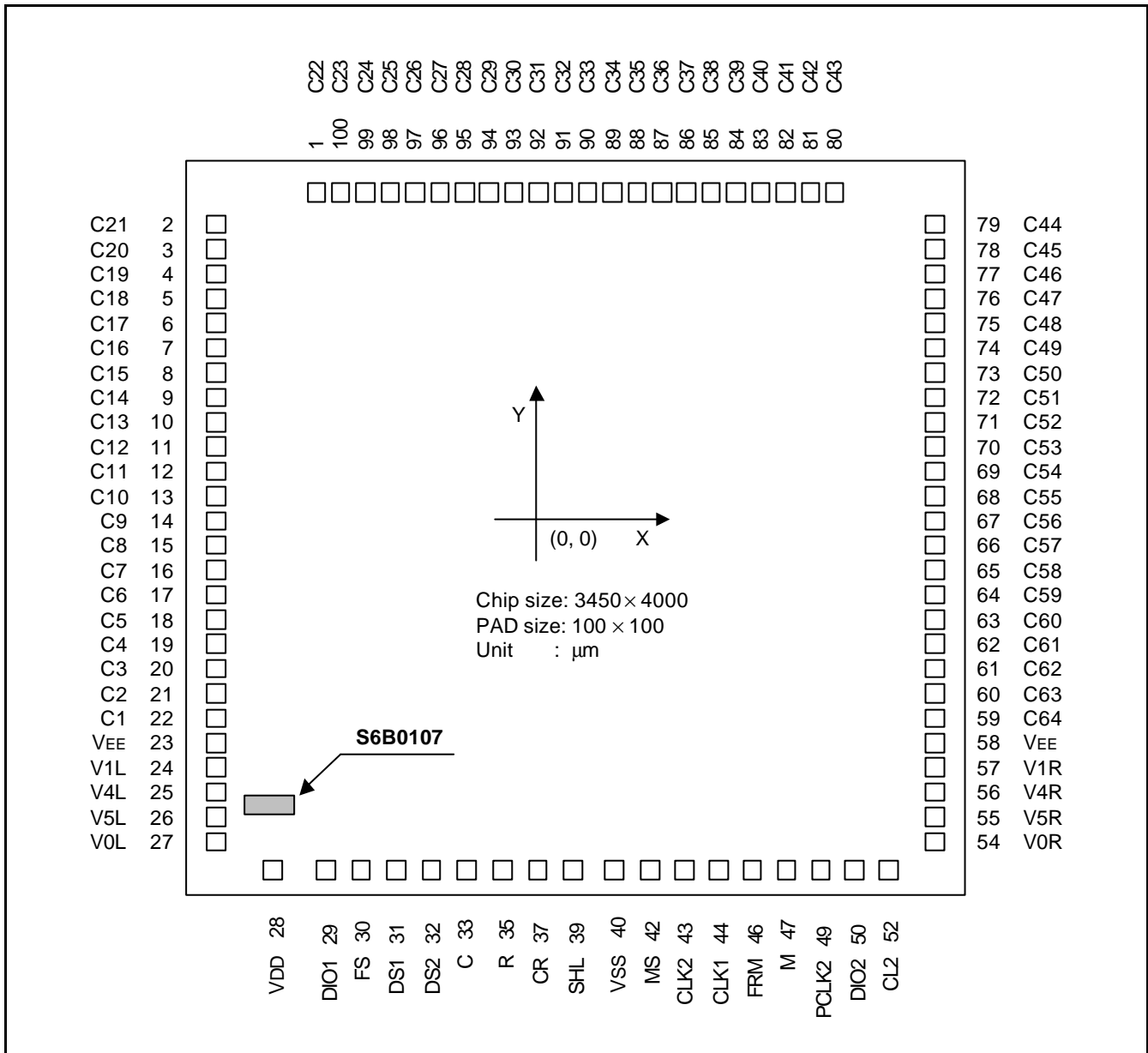

There is the mark S6B0107 on the center of the chip.

PAD CENTER COORDINATES (100QFP)

Pad Number	Pad Name	Coordinate		Pad Number	Pad Name	Coordinate		Pad Number	Pad Name	Coordinate	
		X	Y			X	Y			X	Y
1	C22	-1314.5	1775.4	32	DS2	-677.6	-1775	71	C52	1500.9	630
2	C21	-1499.9	1630	33	C	-527.6	-1775	72	C51	1500.9	755
3	C20	-1499.9	1505	35	R	-377.6	-1775	73	C50	1500.9	880
4	C19	-1499.9	1380	37	CR	-227.6	-1775	74	C49	1500.9	1005
5	C18	-1499.9	1255	39	SHL	-77.6	-1775	75	C48	1500.9	1130
6	C17	-1499.9	1130	40	V _{SS}	113.8	-1775	76	C47	1500.9	1255
7	C16	-1499.9	1005	42	MS	308.7	-1775	77	C46	1500.9	1380
8	C15	-1499.9	880	43	CLK2	458.7	-1775	78	C45	1500.9	1505
9	C14	-1499.9	755	44	CLK1	608.7	-1775	79	C44	1500.9	1630
10	C13	-1499.9	630	46	FRM	758.7	-1775	80	C43	1310.5	1775.4
11	C12	-1499.9	505	47	M	908.7	-1775	81	C42	1185.5	1775.4
12	C11	-1499.9	380	49	PCLK2	1058.7	-1775	82	C41	1060.5	1775.4
13	C10	-1499.9	255	50	DI02	1208.7	-1775	83	C40	935.5	1775.4
14	C9	-1499.9	130	52	CL2	1358.7	-1775	84	C39	810.5	1775.4
15	C8	-1499.9	5	54	V0R	1500.9	-1495	85	C38	685.5	1775.4
16	C7	-1499.9	-120	55	V5R	1500.9	-1370	86	C37	560.5	1775.4
17	C6	-1499.9	-245	56	V4R	1500.9	-1245	87	C36	435.5	1775.4
18	C5	-1499.9	-370	57	V1R	1500.9	-1120	88	C35	310.5	1775.4
19	C4	-1499.9	-495	58	V _{EE}	1500.9	-995	89	C34	185.5	1775.4
20	C3	-1499.9	-620	59	C64	1500.9	-870	90	C33	60.5	1775.4
21	C2	-1499.9	-745	60	C63	1500.9	-745	91	C32	-64.5	1775.4
22	C1	-1499.9	-870	61	C62	1500.9	-620	92	C31	-189.5	1775.4
23	V _{EE}	-1499.9	-995	62	C61	1500.9	-495	93	C30	-314.5	1775.4
24	V1L	-1499.9	-1120	63	C60	1500.9	-370	94	C29	-439.5	1775.4
25	V4L	-1499.9	-1245	64	C59	1500.9	-245	95	C28	-564.5	1775.4
26	V5L	-1499.9	-1370	65	C58	1500.9	-120	96	C27	-689.5	1775.4
27	V0L	-1499.9	-1495	66	C57	1500.9	5	97	C26	-814.5	1775.4
28	V _{DD}	-1345.6	-1775	67	C56	1500.9	130	98	C25	-939.5	1775.4
29	DI01	-1127.6	-1775	68	C55	1500.9	255	99	C24	-1064.5	1775.4
30	FS	-977.6	-1775	69	C54	1500.9	380	100	C23	-1189.5	1775.4
31	DS1	-827.6	-1775	70	C53	1500.9	505				

100-TQFP (S6B2107)

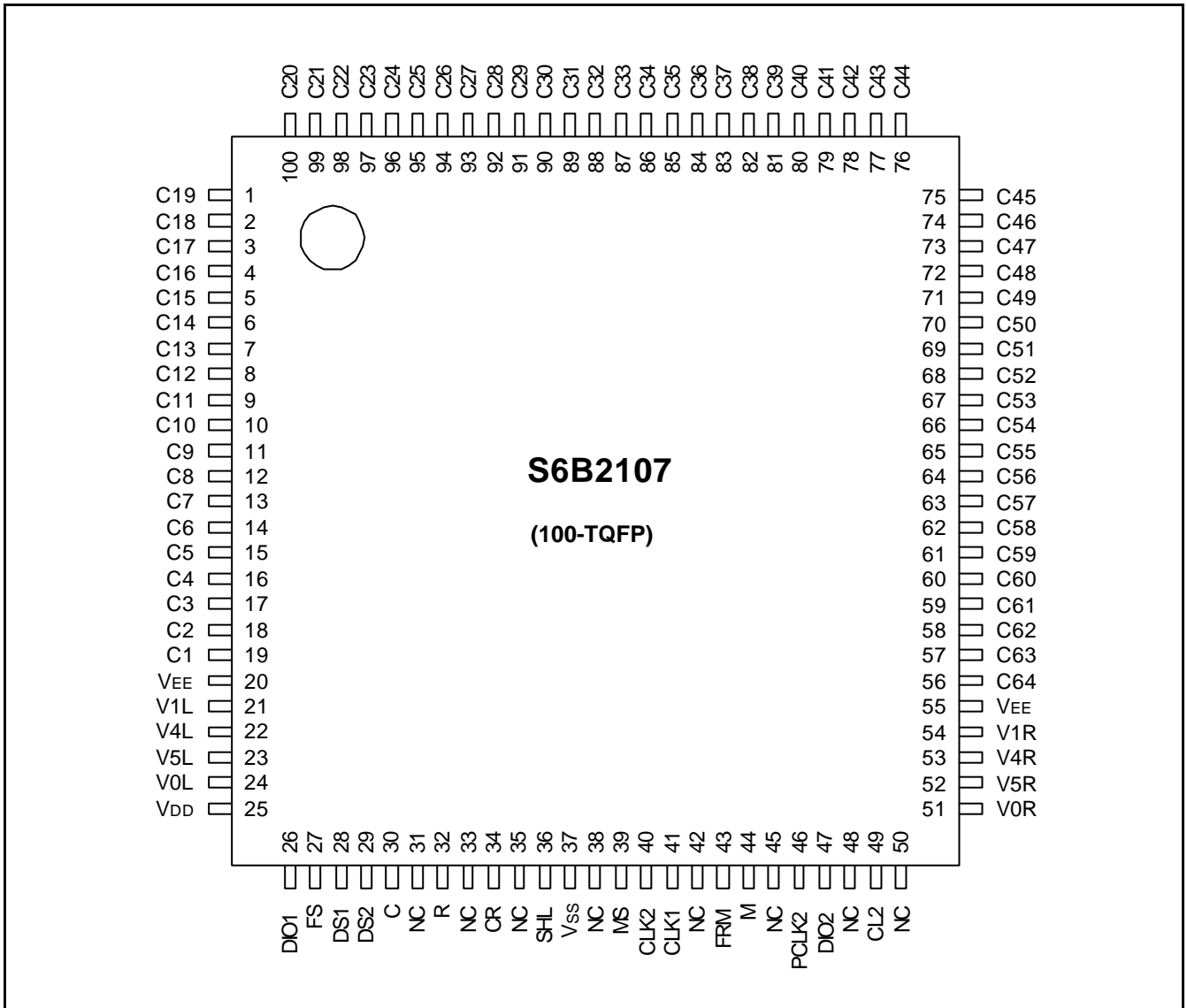

PAD DIAGRAM (CHIP LAYOUT FOR THE 100-TQFP)

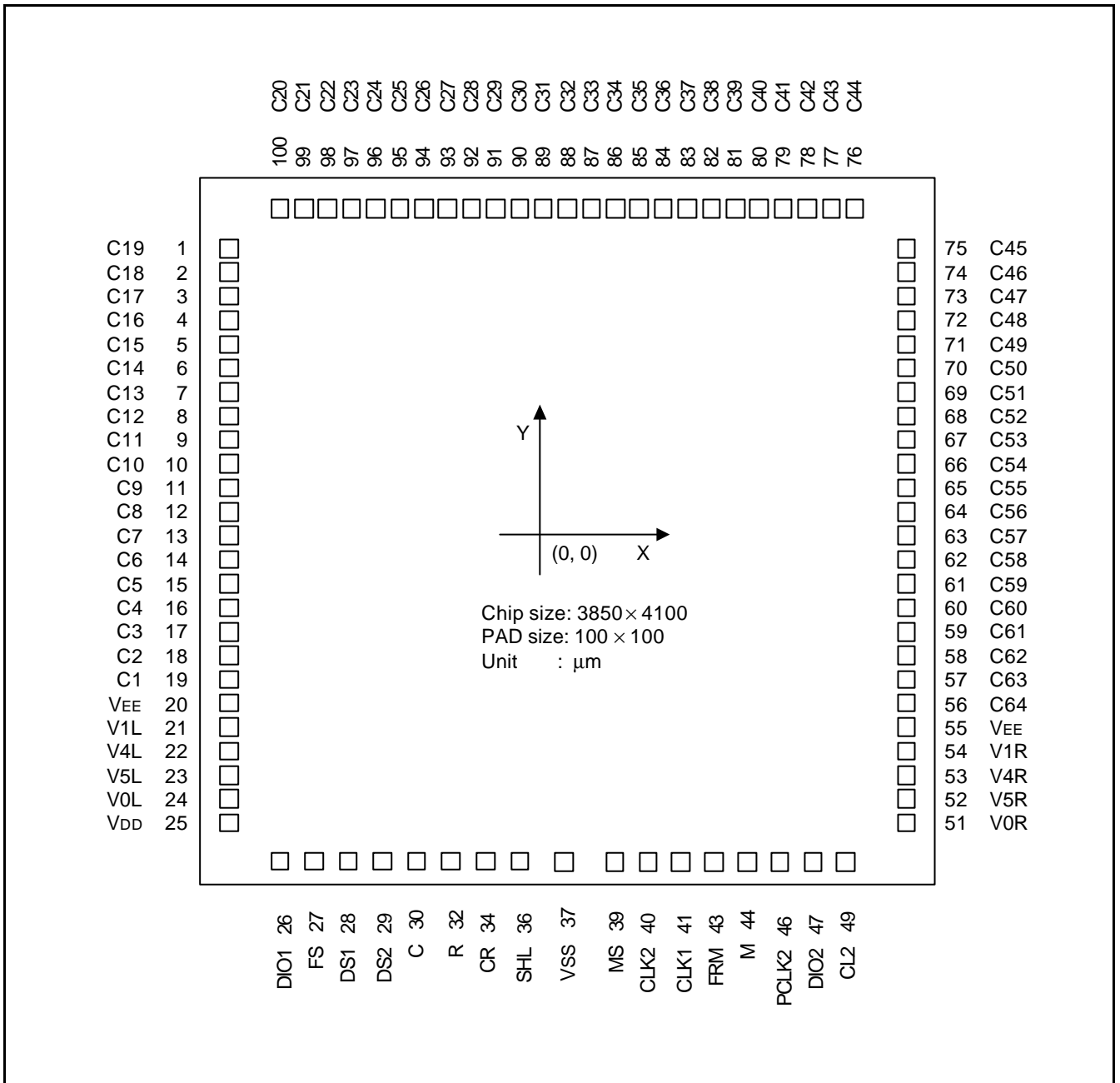

NOTE: There is the mark S6B2107 on the center of the chip.

PAD CENTER COORDINATES (100-TQFP)

Pad Number	Pad Name	Coordinate		Pad Number	Pad Name	Coordinate		Pad Number	Pad Name	Coordinate	
		X	Y			X	Y			X	Y
1	C19	-1697	1534	35	NC			69	C51	1697	784
2	C18	-1697	1409	36	SHL	-195	-1821	70	C50	1697	909
3	C17	-1697	1284	37	V _{SS}	0	-1821	71	C49	1697	1034
4	C16	-1697	1159	38	NC			72	C48	1697	1159
5	C15	-1697	1034	39	MS	195	-1821	73	C47	1697	1284
6	C14	-1697	909	40	CLK2	345	-1821	74	C46	1697	1409
7	C13	-1697	784	41	CLK1	495	-1821	75	C45	1697	1534
8	C12	-1697	659	42	NC			76	C44	1500	1822
9	C11	-1697	534	43	FRM	645	-1821	77	C43	1375	1822
10	C10	-1697	409	44	M	795	-1821	78	C42	1250	1822
11	C9	-1697	284	45	NC			79	C41	1125	1822
12	C8	-1697	159	46	PCLK2	945	-1821	80	C40	1000	1822
13	C7	-1697	34	47	DIO2	1095	-1821	81	C39	875	1822
14	C6	-1697	-91	48	NC			82	C38	750	1822
15	C5	-1697	-216	49	CL2	1245	-1821	83	C37	625	1822
16	C4	-1697	-341	50	NC			84	C36	500	1822
17	C3	-1697	-466	51	V0R	1697	-1466	85	C35	375	1822
18	C2	-1697	-591	52	V5R	1697	-1341	86	C34	250	1822
19	C1	-1697	-716	53	V4R	1697	-1216	87	C33	125	1822
20	V _{EE}	-1697	-841	54	V1R	1697	-1091	88	C32	0	1822
21	V1L	-1697	-966	55	V _{EE}	1697	-966	89	C31	-125	1822
22	V4L	-1697	-1091	56	C64	1697	-841	90	C30	-250	1822
23	V5L	-1697	-1216	57	C63	1697	-716	91	C29	-375	1822
24	V0L	-1697	-1341	58	C62	1697	-591	92	C28	-500	1822
25	V _{DD}	-1697	-1466	59	C61	1697	466	93	C27	-625	1822
26	DIO1	-1245	-1821	60	C60	1697	-341	94	C26	-750	1822
27	FS	-1095	-1821	61	C59	1697	-216	95	C25	-875	1822
28	DS1	-945	-1821	62	C58	1697	-91	96	C24	-1000	1822
29	DS2	-795	-1821	63	C57	1697	34	97	C23	-1125	1822

30	C	-645	-1821	64	C56	1697	159	98	C22	-1250	1822
31	NC			65	C55	1697	284	99	C21	-1375	1822
32	R	-495	-1821	66	C54	1697	409	100	C20	-1500	1822
33	NC			67	C53	1697	534				
34	CR	-345	-1821	68	C52	1697	659				

PIN DESCRIPTION

Table 1. Pin Description

Pin Number QFP (TQFP)	Symbol	I/O	Description						
28(25) 40(37) 23(20), 58(55)	V_{DD} V_{SS} V_{EE}	Power	For internal logic circuit (+5V ± 10%) GND (= 0 V) For LCD driver circuit						
27(24), 54(51) 24(21), 57(54) 25(22), 56(53) 26(23), 55(52)	V0L, V0R V1L, V1R V4L, V4R V5L, V5R	Power	Bias supply voltage terminals to drive LCD. <table border="1" style="margin-left: 20px;"> <thead> <tr> <th>Select Level</th> <th>Non-Select Level</th> </tr> </thead> <tbody> <tr> <td>V0L (R), V5L (R)</td> <td>V1L (R), V4L (R)</td> </tr> </tbody> </table> <p>V0L and V0R (V1L & V1R, V4L & V4R, V5L & V5R) should be connected by the same voltage.</p>	Select Level	Non-Select Level	V0L (R), V5L (R)	V1L (R), V4L (R)		
Select Level	Non-Select Level								
V0L (R), V5L (R)	V1L (R), V4L (R)								
42(39)	MS	Input	Selection of master/slave mode - Master mode (MS = 1) DIO1, DIO2, CL2 and M is output state. - Slave mode (MS = 0) SHL = 1 → DIO1 is input state (DIO2 is output state) SHL = 0 → DIO2 is input state (DIO1 is output state) CL2 and M are input state.						
39(36)	SHL	Input	Selection of data shift direction. <table border="1" style="margin-left: 20px;"> <thead> <tr> <th>SHL</th> <th>Data Shift Direction</th> </tr> </thead> <tbody> <tr> <td>H</td> <td>DIO1 → C1 C64 → DIO0</td> </tr> <tr> <td>L</td> <td>DIO2 → C64 C1 → DIO0</td> </tr> </tbody> </table>	SHL	Data Shift Direction	H	DIO1 → C1 C64 → DIO0	L	DIO2 → C64 C1 → DIO0
SHL	Data Shift Direction								
H	DIO1 → C1 C64 → DIO0								
L	DIO2 → C64 C1 → DIO0								
49(46)	PCLK2	Input	Selection of shift clock (CL2) phase. <table border="1" style="margin-left: 20px;"> <thead> <tr> <th>PCLK2</th> <th>Shift Clock (CL2) Phase</th> </tr> </thead> <tbody> <tr> <td>H</td> <td>Data shift at the rising edge of CL2</td> </tr> <tr> <td>L</td> <td>Data shift at the falling edge of CL2</td> </tr> </tbody> </table>	PCLK2	Shift Clock (CL2) Phase	H	Data shift at the rising edge of CL2	L	Data shift at the falling edge of CL2
PCLK2	Shift Clock (CL2) Phase								
H	Data shift at the rising edge of CL2								
L	Data shift at the falling edge of CL2								
30(27)	FS	Input	Selection of oscillation frequency. - Master mode When the frame frequency is 70 Hz, the oscillation frequency should be $f_{osc} = 430\text{kHz}$ at FS = 1(V_{DD}) $f_{osc} = 215\text{kHz}$ at FS = 0(V_{SS}) - Slave mode Connect to V_{DD} .						

Table 1. Pin Description (Continued)

Pin Number QFP (TQFP)	Symbol	I/O	Description																		
31(28) 32(29)	DS1 DS2	Input	<p>Selection of display duty.</p> <ul style="list-style-type: none"> - Master mode <table border="1"> <thead> <tr> <th>DS1</th> <th>DS2</th> <th>Duty</th> </tr> </thead> <tbody> <tr> <td>L</td> <td>L</td> <td>1/48</td> </tr> <tr> <td>L</td> <td>H</td> <td>1/64</td> </tr> <tr> <td>H</td> <td>L</td> <td>1/96</td> </tr> <tr> <td>H</td> <td>H</td> <td>1/128</td> </tr> </tbody> </table> <ul style="list-style-type: none"> - Slave mode Connect to V_{DD} 	DS1	DS2	Duty	L	L	1/48	L	H	1/64	H	L	1/96	H	H	1/128			
DS1	DS2	Duty																			
L	L	1/48																			
L	H	1/64																			
H	L	1/96																			
H	H	1/128																			
33(30) 35(32) 37(34)	C R CR		<p>RC Oscillator</p> <ul style="list-style-type: none"> - Master mode: Use these terminals as shown below. <ul style="list-style-type: none"> - Slave mode: Stop the oscillator as shown below. 																		
44(41) 43(40)	CLK1 CLK2	Output	<p>Operating clock output for the S6B0108</p> <ul style="list-style-type: none"> - Master mode: connection to CLK1 and CLK2 of the S6B0108 - Slave mode: open 																		
46(43)	FRM	Output	<p>Synchronous frame signal.</p> <ul style="list-style-type: none"> - Master mode: connection to FRM of the S6B0108 - Slave mode: open 																		
47(44)	M	Input/ Output	<p>Alternating signal input for LCD driving.</p> <ul style="list-style-type: none"> - Master mode: output state Connection to M of the S6B0108 - Slave mode: input state Connection to the controller 																		
52(49)	CL2	Input / Output	<p>Data shift clock</p> <ul style="list-style-type: none"> - Master mode: output state Connection to CL of the S6B0108 - Slave mode: input state Connection to shift clock terminal of the controller. 																		
29(26) 50(47)	DIO1 DIO2	Input/ Output	<p>Data input/output pin of internal shift register.</p> <table border="1"> <thead> <tr> <th>MS</th> <th>DS2</th> <th>DIO1</th> <th>DIO2</th> </tr> </thead> <tbody> <tr> <td rowspan="2">H</td> <td>H</td> <td>Output</td> <td>Output</td> </tr> <tr> <td>L</td> <td>Output</td> <td>Output</td> </tr> <tr> <td rowspan="2">L</td> <td>H</td> <td>Input</td> <td>Output</td> </tr> <tr> <td>L</td> <td>Output</td> <td>Input</td> </tr> </tbody> </table>	MS	DS2	DIO1	DIO2	H	H	Output	Output	L	Output	Output	L	H	Input	Output	L	Output	Input
MS	DS2	DIO1	DIO2																		
H	H	Output	Output																		
	L	Output	Output																		
L	H	Input	Output																		
	L	Output	Input																		

Table 1. Pin Description (Continued)

Pin Number QFP (TQFP)	Symbol	I/O	Description															
22-1(19-1) 100-59(100-56)	C1-C64	Output	Common signal output for LCD driving. <table border="1" style="margin-left: 20px;"> <thead> <tr> <th>Data</th> <th>M</th> <th>Out</th> </tr> </thead> <tbody> <tr> <td>L</td> <td>L</td> <td>V₁</td> </tr> <tr> <td>L</td> <td>H</td> <td>V₄</td> </tr> <tr> <td>H</td> <td>L</td> <td>V₅</td> </tr> <tr> <td>H</td> <td>H</td> <td>V₀</td> </tr> </tbody> </table>	Data	M	Out	L	L	V ₁	L	H	V ₄	H	L	V ₅	H	H	V ₀
Data	M	Out																
L	L	V ₁																
L	H	V ₄																
H	L	V ₅																
H	H	V ₀																
34(31), 36(33) 38(35), 41(38) 45(42), 48(45) 51(48), 53(50)	NC		No connection															

MAXIMUM ABSOLUTE LIMIT

Characteristic	Symbol	Value	Unit	Note
Operating voltage	V _{DD}	-0.3 - +7.0	V	(1)
Supply voltage	V _{EE}	V _{DD} -19.0 - V _{DD} +0.3	V	(4)
Driver supply voltage	V _B	-0.3 - V _{DD} +0.3	V	(1), (2)
	V _{LCD}	V _{EE} -0.3 - V _{DD} +0.3	V	(3), (4)
Operating temperature	T _{OPR}	-30 - +85	°C	-
Storage temperature	T _{STG}	-55 - +125	°C	-

NOTES:

- Based on V_{SS} = 0V
- Applies to input terminals and I/O terminals at high impedance. (Except V0L(R), V1L(R), V4L(R) and V5L(R)).
- Applies to V0L(R), V1L(R), V4L(R) and V5L(R).
- Voltage level: V_{DD} ≥ V0L = V0R ≥ V1L = V1R ≥ V4L = V4R ≥ V5L = V5R ≥ V_{EE}.

ELECTRICAL CHARACTERISTICS

DC CHARACTERISTICS

($V_{DD} = +5V \pm 10\%$, $V_{SS} = 0V$, $|V_{DD} - V_{EE}| = 8 - 17V$, $T_a = -30$ to $+85^\circ C$)

Characteristic		Symbol	Condition	Min	Typ	Max	Unit	Note
Input Voltage	High	V_{IH}	-	$0.7V_{DD}$	-	V_{DD}	V	(1)
	Low	V_{IL}		V_{SS}	-	$0.3V_{DD}$		
Output Voltage	High	V_{OH}	$I_{OH} = -0.4mA$	$V_{DD} - 0.4$	-	-	V	(2)
	Low	V_{OL}	$I_{OL} = 0.4mA$	-	-	0.4		
Input leakage current		I_{LKG}	$V_{IN} = V_{DD} - V_{SS}$	-1.0	-	1.0	μA	(1)
OSC frequency		f_{OSC}	$R_f = 47k\Omega \pm 2\%$ $C_f = 20pf \pm 5\%$	315	450	585	kHz	
On resistance (VDIV-Cl)		R_{ON}	$V_{DD} - V_{EE} = 17V$ Load current = $\pm 150\mu A$	-	-	1.5	K Ω	
Operating current		I_{DD1}	Master mode 1/128 Duty	-	-	1.0	mA	(3)
		I_{DD2}	Slave mode 1/128 Duty	-	-	200	μA	(4)
Supply current		I_{EE}	Master mode 1/128 Duty	-	-	100		(5)
Operating Frequency		f_{op1}	Master mode External clock	50	-	600	kHz	
Frequency		f_{op2}	Slave mode	0.5	-	1500		

NOTES:

- Applies to input terminals FS, DS1, DS2, CR, SHL, MS and PCLK2 and I/O terminals DIO1, DIO2, M and CL2 in the input state.
- Applies to output terminals CLK1, CLK2 and FRM and I/O terminals DIO1, DIO2, M and CL2 in the output state.
- This value is specified at about the current flowing through V_{SS} . Internal oscillation circuit: $R_f = 47k\Omega$, $C_f = 20pF$ Each terminal of DS1, DS2, FS, SHL and MS is connected to V_{DD} and out is no load.
- This value is specified at about the current flowing through V_{SS} . Each terminal of DS1, DS2, FS, SHL, PCLK2 and CR is connected to V_{DD} , and MS is connected to V_{SS} . CL2, M, DIO1 is external clock.
- This value is specified at about the current flowing through V_{EE} . Don't connect to V_{LCD} (V1-V5).

AC CHARACTERISTICS ($V_{DD} = 5V \pm 10\%$, $T_A = -30^{\circ}C$ to $+85^{\circ}C$)

Master Mode

($MS = V_{DD}$, $PCLK2 = V_{DD}$, $C_f = 20pF$, $R_f = 47k\Omega$)

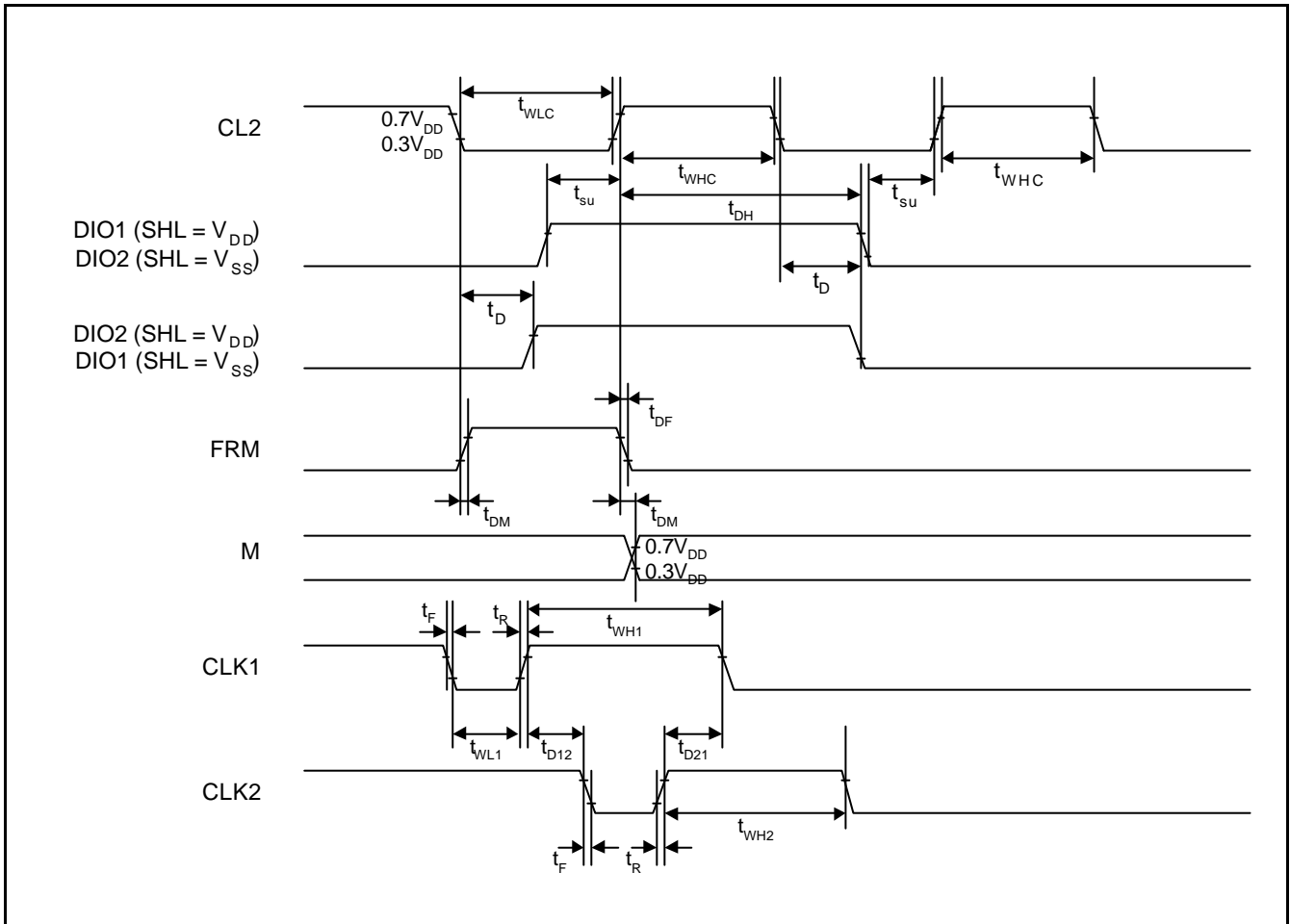

Master Mode

Characteristic	Symbol	Min	Typ	Max	Unit
Data setup time	t_{SU}	20	–	–	μs
Data hold time	t_{DH}	40	–	–	
Data delay time	t_D	5	–	–	
FRM delay time	t_{DF}	-2	–	2	
M delay time	t_{DM}	-2	–	2	
CL2 low level width	t_{WLC}	35	–	–	
CL2 high level width	t_{WHC}	35	–	–	ns
CLK1 low level width	t_{WL1}	700	–	–	
CLK2 low level width	t_{WL2}	700	–	–	
CLK1 high level width	t_{WH1}	2100	–	–	
CLK2 high level width	t_{WH2}	2100	–	–	
CLK1-CLK2 phase difference	t_{D12}	700	–	–	
CLK2-CLK1 phase difference	t_{D21}	700	–	–	
CLK1, CLK2 rise/fall time	t_R/t_F	–	–	150	

Slave Mode (MS = V_{SS})

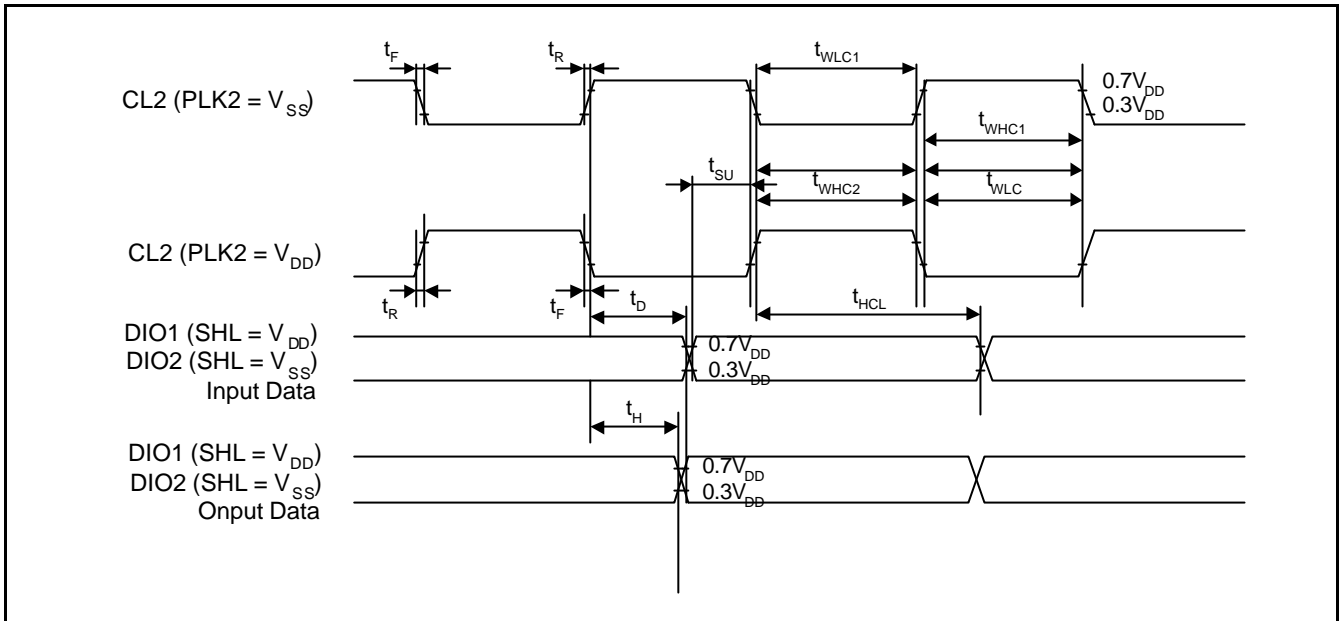

Characteristics	Symbol	Min	Typ	Max	Unit	Note
CL2 low level width	t _{WLC1}	450	–	–	ns	PCLK2 = V _{SS}
CL2 high level width	t _{WHL}	450	–	–	ns	PCLK2 = V _{DD}
CL2 low level width	t _{WLC2}	150	–	–	ns	PCLK2 = V _{DD}
CL2 high level width	t _{WHL}	450	–	–	ns	PCLK2 = V _{DD}
Data setup time	t _{SU}	100	–	–	ns	
Data hold time	t _{DH}	100	–	–	ns	
Data delay time	t _D	–	–	200	ns	(NOTE)
Output data hold time	t _H	10	–	–	ns	
CL2 rise/fall time	t _R /t _F	–	–	30	ns	

NOTE: Connect load CL = 30pF

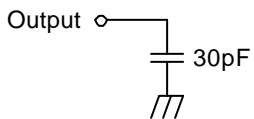

FUNCTIONAL DESCRIPTION

RC Oscillator

The RC Oscillator generates CL2, M, FRM of the S6B0107, and CLK1 and CLK2 of the S6B0108 by the oscillation resistor R and capacitor C.

When selecting the master/slave mode, the oscillation circuit is as following:

Master Mode: In the master mode, use these terminals as shown below.

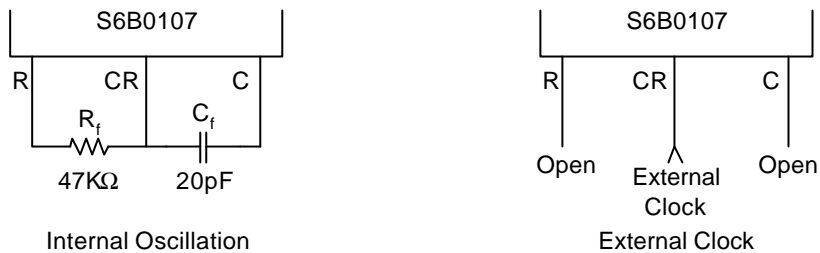

Slave Mode: In the slave mode, stop the oscillator as shown below.

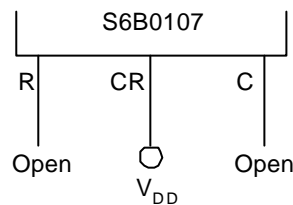

Timing Generation Circuit

It generates CL2, M, FRM, CLK1 and CLK2 by the frequency from the oscillation circuit.

Selection of Master/Slave (M/S) Mode

- When M/S is "H", it generates CL2, M, FRM, CLK1 and CLK2 internally.
- When M/S is "L", it operates by receiving M and CL2 from the mater device

Frequency Selection (FS)

To adjust FRM frequency by 70Hz, the oscillation frequency should be as follows:

FS	Oscillation Frequency
H	$f_{OSC} = 430\text{kHz}$
L	$f_{OSC} = 215\text{kHz}$

In the slave mode, it is connected to V_{DD} .

Duty Selection (DS1, DS2)

It provides various duty selections according to DS1 and DS2.

DS1	DS2	DUTY
L	L	1/48
	H	1/64
H	L	1/96
	H	1/128

Data Shift & Phase Select Control

Phase Selection

It is a circuit to shift data on synchronization or rising edge, or falling edge of the CL2 according to PCLK2.

PCLK2	Phase Selection
H	Data shift on rising edge of CL2
L	Data shift on falling edge of CL2

Data Shift Direction Selection

When M/S is connected to V_{DD} , DIO1 and DIO2 terminal is only output.

When M/S is connected to V_{SS} , it depends on the SHL.

MS	SHL	DIO1	DIO2	Direction of Data
H	H	Output	Output	C1 → C64
	L	Output	Output	C64 → C1
L	H	Input	Output	DIO1 → C1 → C64 → DIO2
	L	Output	Input	DIO2 → C64 → C1 → DIO1

TIMING DIAGRAM

1/48 DUTY TIMING (MASTER MODE)

Condition: DS1 = L, DS2 = L, SHL = H(L), PCLK2 = H

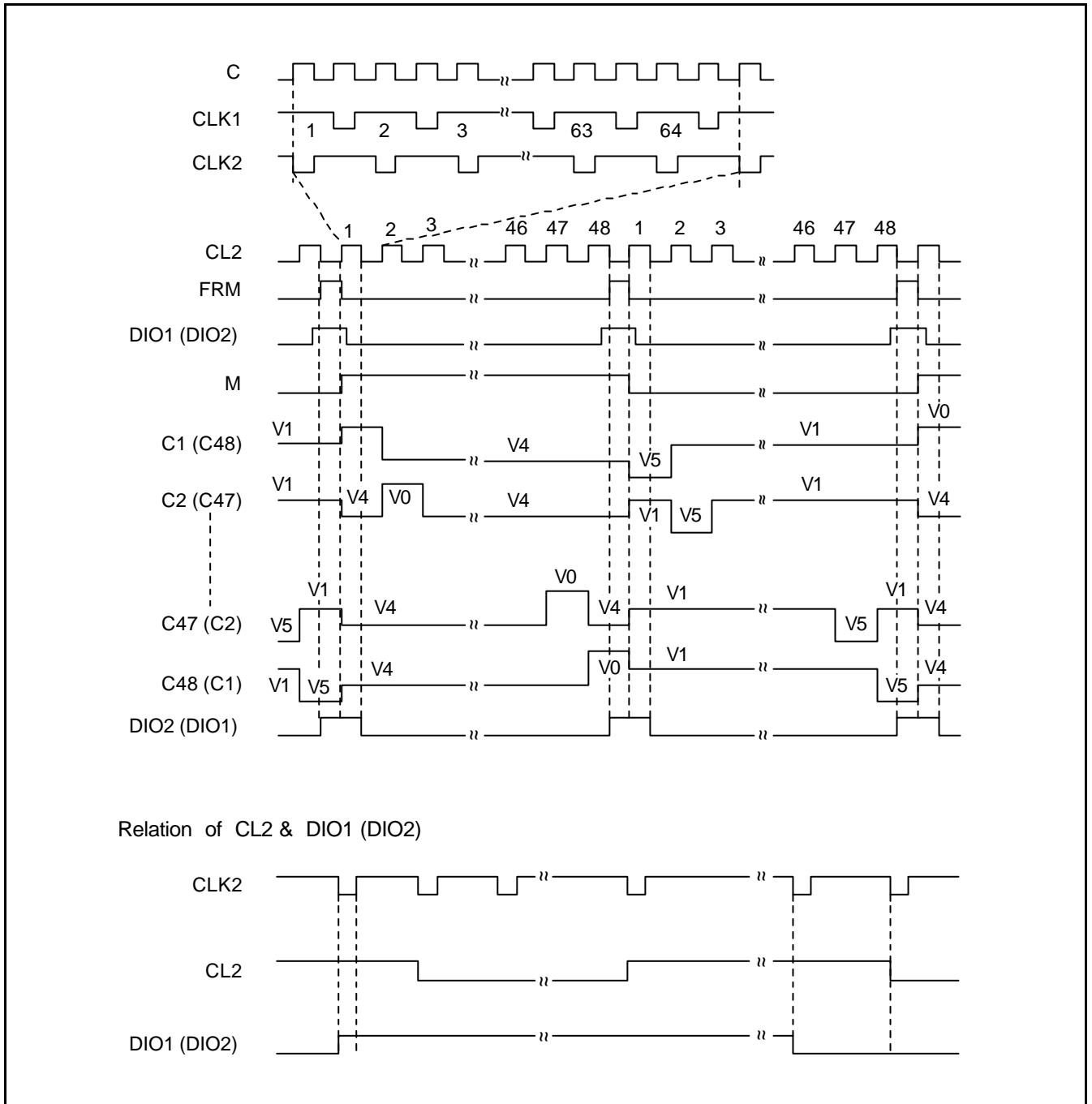

1/128 DUTY TIMING (MASTER MODE)

Condition: DS1 = H, DS2 = H, SHL = H(L), PCLK2 = H

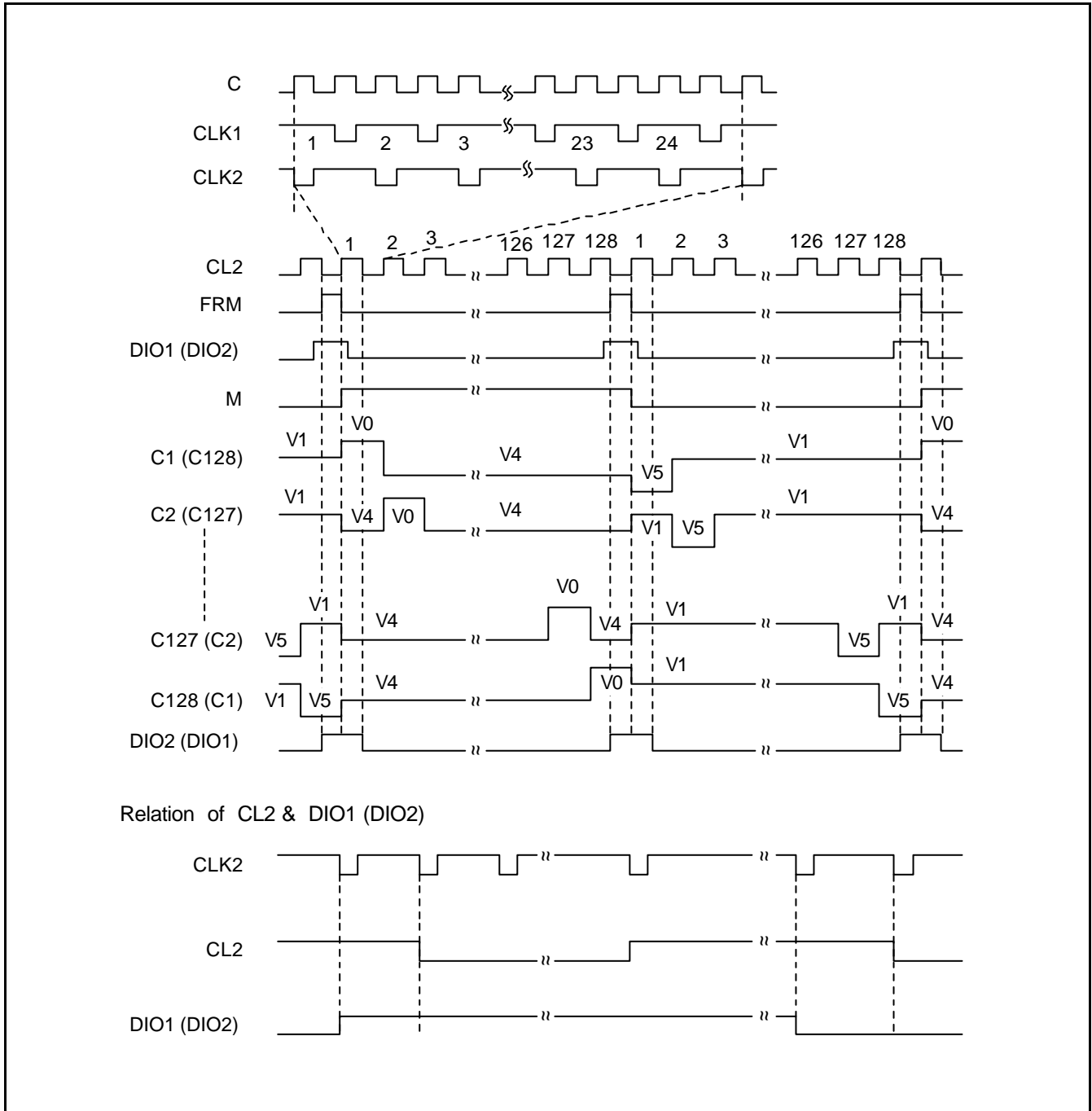

1/48 DUTY TIMING (SLAVE MODE)

Condition: PCLK2 = L, SHL = H(L)

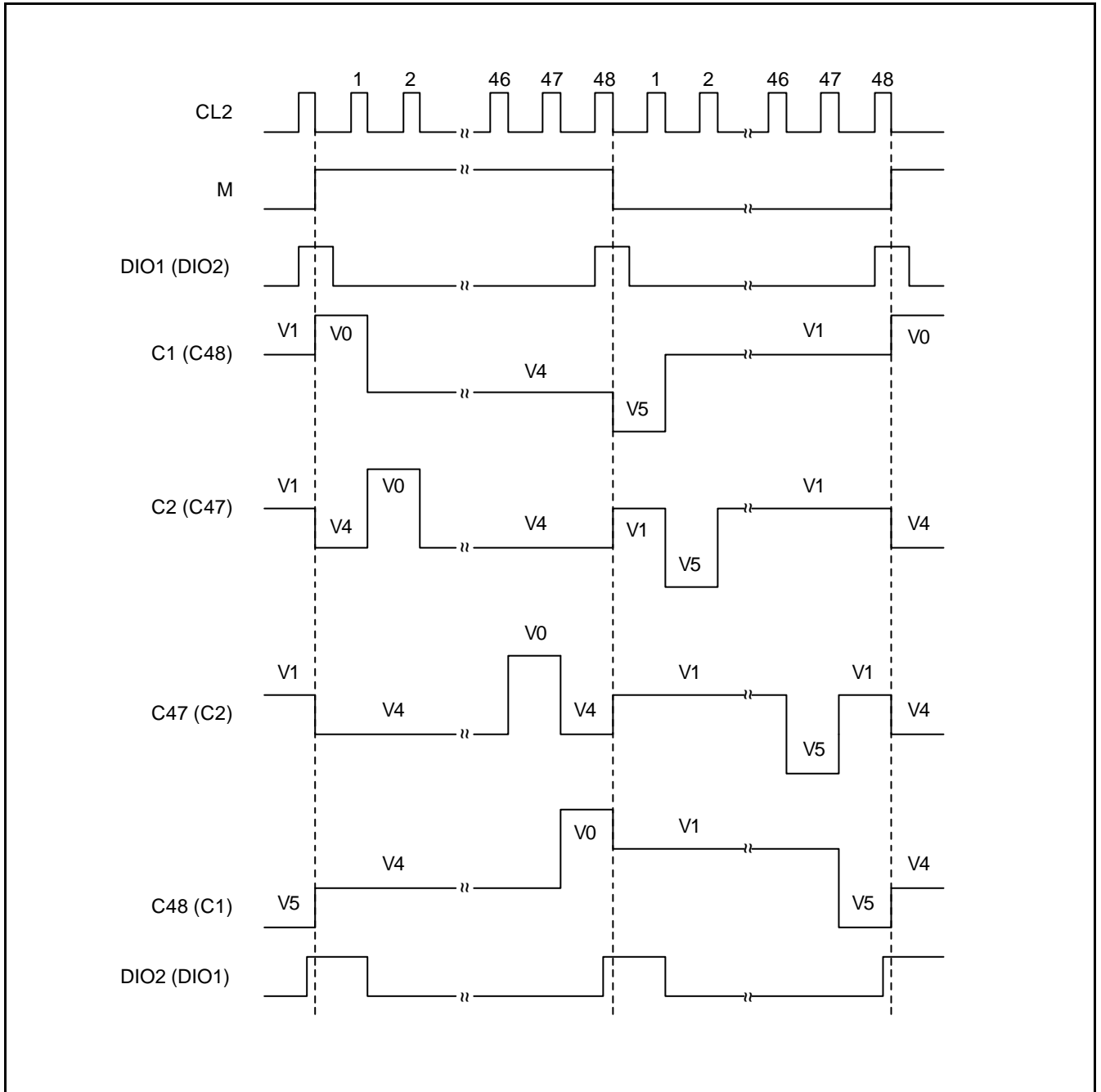

POWER DRIVER CIRCUIT

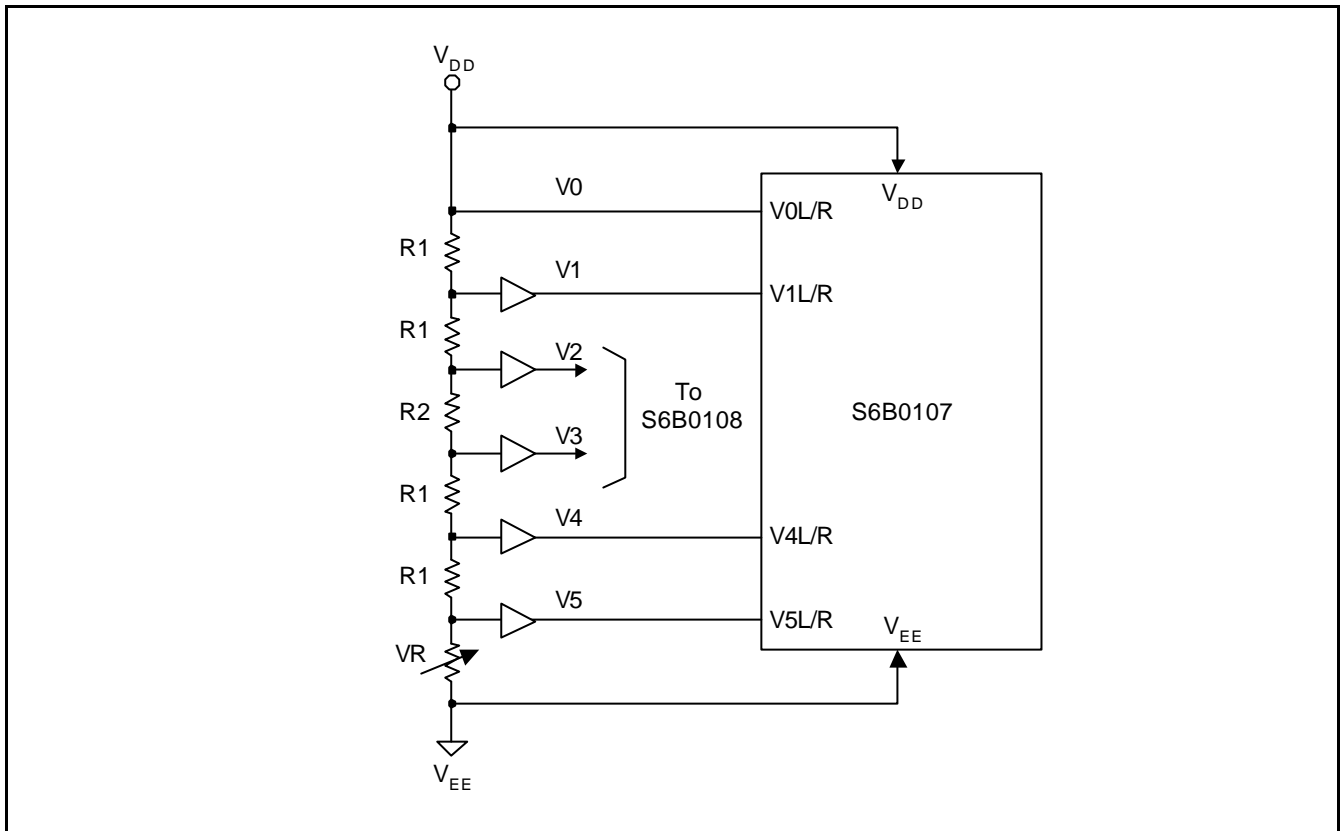

Relation of Duty & Bias

Duty	Bias	RDIV
1/48	1/8	$R2 = 4R1$
1/64	1/9	$R2 = 5R1$
1/96	1/11	$R2 = 7R1$
1/128	1/12	$R2 = 8R1$

When duty factor is 1/48, the value of R1 & R2 should satisfy.

$$R1/(4R1 + R2) = 1/8$$

$$R1 = 3k\Omega, R2 = 12k\Omega$$

APPLICATION CIRCUIT

1/128 duty segment drive (S6B0108) interface circuit

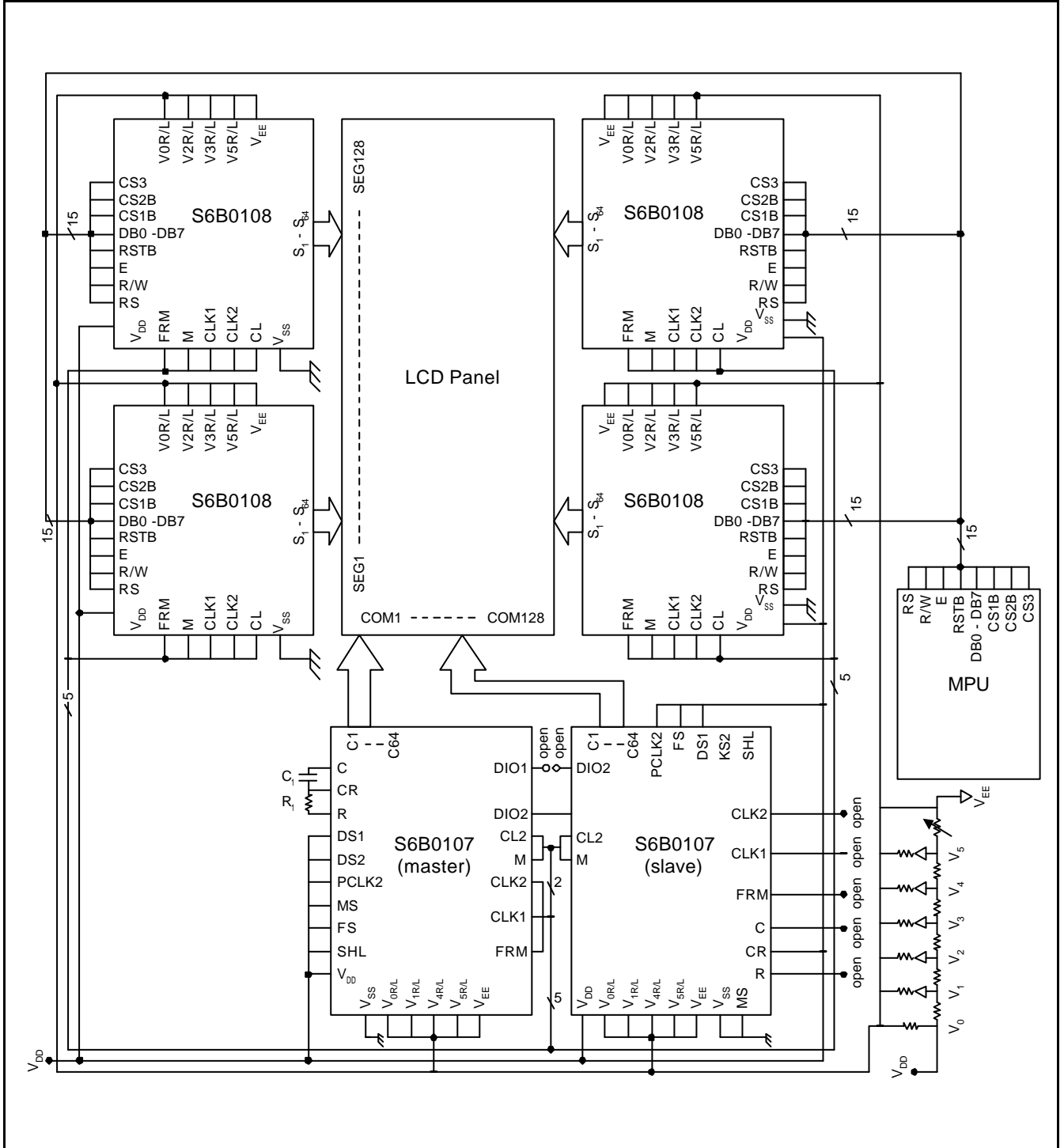

With collaboration of <https://www.displayfuture.com>