



OTA7159A

1536CH TFT LCD Source Driver with TCON

Preliminary

FEB. 20, 2012

Version 0.1

Table of Contents

	<u>PAGE</u>
1. GENERAL DESCRIPTION	4
2. FEATURES	4
3. BLOCK DIAGRAM	5
4. SIGNAL DESCRIPTIONS	6
4.1. PAD DESCRIPTION	6
4.1.1. Left side cascade signals	10
4.1.2. Right side cascade signals	10
4.2. VALUE OF WIRING RESISTANCE TO EACH PIN	11
5. FUNCTIONAL DESCRIPTIONS	12
5.1. POWER ON/OFF SEQUENCE	12
5.2. LVDS DATA MAPPING	13
5.3. BIST FUNCTION	14
5.3.1. BIST pattern	14
5.3.2. BIST Timing	14
5.4. CABC ARCHITECTURE	15
5.5. TCON TIMING	15
5.5.1. Polarity control	15
5.5.2. Gate driver timing (Single Gate)	16
5.5.3. Gate driver timing (Dual Gate)	17
5.6. APPLICATION DIAGRAM	18
5.6.1. Cascade Application (DGEN=0), Gate IC on left (GATELOC=1), 1024 x 768 as example	18
5.6.2. Cascade Application (DGEN=0), Gate IC on right (GATELOC=0), 1024 x 768 as example	19
5.6.3. Dual Gate Application (DGEN=1), Gate IC on left (GATELOC=1), 1024 x 600 as example	20
5.6.4. Dual Gate Application (DGEN=1), Gate IC on right (GATELOC=0), 1024 x 600 as example	21
5.6.5. Power supply application circuit	22
5.7. USEFUL & USELESS CHANNEL OF SOURCE DRIVER	23
5.8. INPUT DATA VS OUTPUT VOLTAGE	23
5.9. GAMMA CORRECTION RESISTOR RATIO	24
5.10. OUTPUT VOLTAGE VS. INPUT DATA	25
6. ELECTRICAL SPECIFICATIONS	27
6.1. ABSOLUTE MAXIMUM RATINGS	27
6.2. RECOMMENDED OPERATING CONDITIONS	27
6.3. DC CHARACTERISTICS	28
6.3.1. System characteristics	28
6.3.2. LVDS DC characteristics	28
6.4. LVDS DC CHARACTERISTICS	28
6.5. AC CHARACTERISTICS	29
6.5.1. System AC characteristics	29
6.5.2. Parallel RGB AC characteristics	29
6.5.3. LVDS AC characteristics	30

7. CHIP INFORMATION	34
7.1. PAD ASSIGNMENT	34
7.2. PAD DIMENSION	34
7.3. PAD LOCATION	35
7.4. ALIGNMENT MARK	46
8. DISCLAIMER	47
9. REVISION HISTORY	48

ORISE Tech Confidential
For 瑞达威 Use Only

1536CH TFT LCD Source Driver with TCON

1. GENERAL DESCRIPTION

OTA7159A is a highly integrated 1536 channel source driver with LVDS and TTL interface Timing Controller for color TFT-LCD panels. OTA7159A integrated source driver, timing controller and pin control Interface.

Input timing supports both LVDS and TTL digital 24bit parallel RGB data format. Source output support 8-bit resolution 256 grayscale with dithering features. Operating parameters can be set via OTP and pin control for all control features.

Special circuit architecture is designed for lower power dissipation.

2. FEATURES

- Special design for medium-sized color TFT LCD source drivers with timing controller
- Integrated 1536 channel source driver
- Supports display resolutions : 1024(RGB)x600,1024(RGB)x768, 800(RGB)x600,800(RGB)480,960(RGB)x540,
- 8-bit resolution 256 gray scale with 2-bits dithering
- Supports LVDS and TTL 24-bit parallel (RGB) input timing
- Support cascade function with bidirectional shift control (CMOS signal)
- Support Dual Gate architecture
- Support stand-by mode for low power consumption
- Support dot inversion driving scheme
- Built-in OTP for internal parameter setting
- Cooperate with external or internal programmable gamma buffer to achieve CABC function for reducing backlight power
- V1~V14 for adjusting external Gamma correction
- Support 1-line and 1+2line polarity inversion
- Support VGH slicing control signal
- Output max. dynamic range : 0.3V ~ VDDA-0.3V
- Max. power for source driver voltage VDDA : 8V ~ 13.5V
- power for digital interface circuit VDD : 2.3v ~ 3.6v
- Operating frequency : 75MHz
- COG package

3. BLOCK DIAGRAM

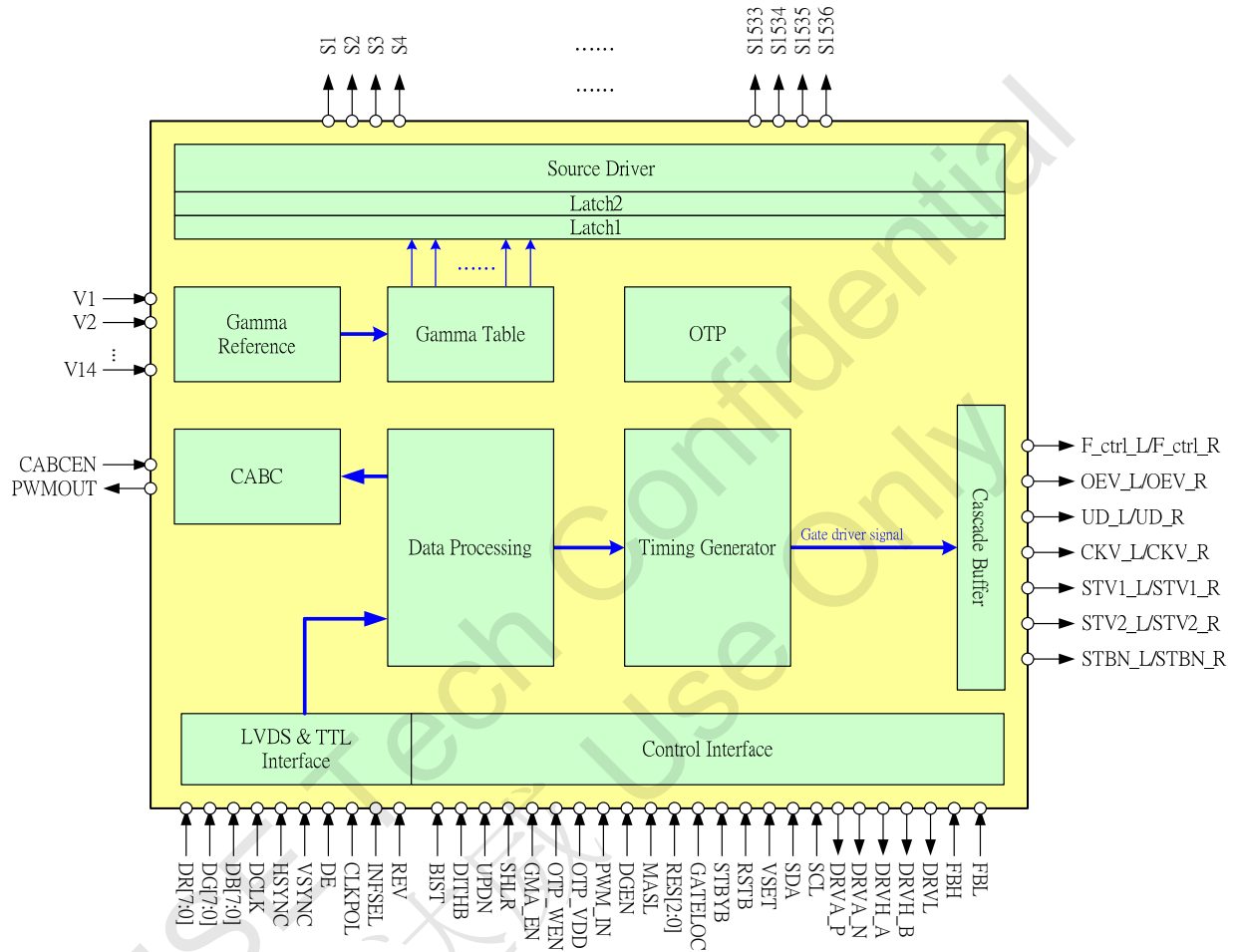

4. SIGNAL DESCRIPTIONS
4.1. Pad Description

Designation	I/O	Description																		
S1 ~ S1536	O	Source Driver output.																		
V1 ~ V14	I	External Gamma voltage input. These voltages must provided by user.																		
SYNC1_L	IO	Cascade data signal for left side pad, gate driver signal output (CABC and BIST sync control)																		
SYNC1_R	IO	Cascade data signal for right side pad, gate driver signal output (CABC and BIST sync control)																		
SYNC2_L	IO	Cascade data signal for left side pad, gate driver signal output (CABC and BIST sync control)																		
SYNC2_R	IO	Cascade data signal for right side pad, gate driver signal output (CABC and BIST sync control)																		
F_Ctrl_L	IO	Cascade data signal for left side pad, gate driver signal output																		
F_Ctrl_R	IO	Cascade data signal for right side pad, gate driver signal output																		
OEV_L	IO	Cascade data signal for left side pad, gate driver signal output																		
OEV_R	IO	Cascade data signal for right side pad, gate driver signal output																		
UD_L	IO	Cascade data signal for left side pad, gate driver signal output																		
UD_R	IO	Cascade data signal for right side pad, gate driver signal output																		
CKV_L	IO	Cascade data signal for left side pad, gate driver signal output																		
CKV_R	IO	Cascade data signal for right side pad, gate driver signal output																		
STV1_L	IO	Cascade data signal for left side pad, gate driver signal output																		
STV1_R	IO	Cascade data signal for right side pad, gate driver signal output																		
STV2_L	IO	Cascade data signal for left side pad, gate driver signal output																		
STV2_R	IO	Cascade data signal for right side pad, gate driver signal output																		
STBN_L	IO	Cascade data signal for left side pad, gate driver signal output																		
STBN_R	IO	Cascade data signal for right side pad, gate driver signal output																		
DCLK	I	INFSEL=L, TTL clock input INFSEL=H, Positive LVDS differential clock input																		
DCLKN	I	Negative LVDS differential clock input																		
D0/D1/D2[7:0]	I	LVDS or Parallel RGB data input. Select by IFSEL pin <table border="1" style="margin-left: 20px;"> <thead> <tr> <th>Input mode</th> <th>TTL</th> <th>LVDS</th> </tr> </thead> <tbody> <tr> <td>INFSEL</td> <td>L</td> <td>H</td> </tr> <tr> <td>D20, D21</td> <td>B0, B1</td> <td>D0N, D0P</td> </tr> <tr> <td>D22, D23</td> <td>B2, B3</td> <td>D1N, D1P</td> </tr> <tr> <td>D24, D25</td> <td>B4, B5</td> <td>D2N, D2P</td> </tr> <tr> <td>D26, D27</td> <td>B6, B7</td> <td>D3N, D3P</td> </tr> </tbody> </table>	Input mode	TTL	LVDS	INFSEL	L	H	D20, D21	B0, B1	D0N, D0P	D22, D23	B2, B3	D1N, D1P	D24, D25	B4, B5	D2N, D2P	D26, D27	B6, B7	D3N, D3P
Input mode	TTL	LVDS																		
INFSEL	L	H																		
D20, D21	B0, B1	D0N, D0P																		
D22, D23	B2, B3	D1N, D1P																		
D24, D25	B4, B5	D2N, D2P																		
D26, D27	B6, B7	D3N, D3P																		
REV	I,PL	Data inverted control. 1: 00->3F, 15->2A, 0: 00->00, 15->15																		
VSYNC	I	In TTL mode, for vertical sync input. Negative polarity In LVDS mode, connected to FPC and pull low																		
HSYNC	I	In TTL mode, for horizontal sync input. Negative polarity In LVDS mode, used as 6-bit/ 8-bit input select <table border="1" style="margin-left: 20px;"> <thead> <tr> <th>HSYNC</th> <th>bit</th> </tr> </thead> <tbody> <tr> <td>L</td> <td>8-bit</td> </tr> <tr> <td>H</td> <td>6-bit</td> </tr> </tbody> </table>	HSYNC	bit	L	8-bit	H	6-bit												
HSYNC	bit																			
L	8-bit																			
H	6-bit																			
DE	I,PL	Data input enable for TTL mode. Active high to enable the data input.																		
CLKPOL	I,PL	Parallel RGB clock polarity control																		
SCL	I,PL	Serial communication clock input.																		
SDA	I,PL	Serial communication data input.																		
CSB	I,PL	Serial communication chip select.																		
MODE	I,PH	DE/ SYNC mode select under TTL mode. Active high to enable the data input.																		
RSTB	I,PH	External reset input, low active Suggest to connecting with an RC reset circuit for stability																		
STBYB	I,PH	External standby mode selection, low active																		
MASL	I,PH	Master / Slave selection, 1 : Master Mode; 0 : Slave Mode																		
GATELOC	I,PL	Gate IC location selection, 1 : Gate IC on left (From panel top view); 0 : Gate IC on right (From panel top view)																		
RES[1:0]	I,PL	Resolution selection																		

Designation	I/O	Description								
		RES1	RES0	Resolution						
		0	0	1024RGBx600 (Default)						
		0	1	1024RGBx768						
		1	0	800RGBx600						
		1	1	800RGBx480						
SHLR	I,PH	Left / Right shift control, 0 : Shift left : S1536 → S1535 → ... → S2 → S1 1 : Shift right, S1 → S2 → S3 → ... → S1536								
UPDN	I,PL	Up / Down rotate control 0 : STV2 output vertical start pulse and UD output logic "0" to gate driver 1 : STV1 output vertical start pulse and UD output logic "1" to gate driver								
INFSEL	I,PL	Interface selection control 0 : TTL interface 1 : LVDS interface When set as LVDS interface, TTL interface (DCLK,DR/G/B,HSYN,VSYN,DE) can be left floating								
DGEN	I,PH	Dual gate function enable / disable, 0 : Disable; 1 : Enable								
CABCEN	I,PL	CABC function enable / disable, 0 : Disable; 1 : Enable								
DITHER	I,PL	Dithering function enable / disable, 0: Disable; 1: Enable								
HFRC	I,PL	H-FRC selection 1: H-FRC enable 0: H-FRC disable								
BIST	I,PL	BIST Mode enable / disable, 0 : Disable; 1 : Enable								
PWMIN	I,PH	PWM input								
PWMOUT	O	PWM output after CABC function								
PINCTRL	I,PH	Enable pin control function. 0: Disable pin control function and 3-wire control register. 1: Enable pin control function								
FRAME	I,PL	Frame inverse or not select. When FRAME=H, Uniform, set SEL=1, only for dual gate When FRAME=L, Frame inverse.								
SEL	I,PL	Gate on sequence select. <table border="1" style="display: inline-table; vertical-align: middle;"> <thead> <tr> <th>SEL</th> <th>Pin control function</th> </tr> </thead> <tbody> <tr> <td>0</td> <td>Z</td> </tr> <tr> <td>1</td> <td>反Z</td> </tr> </tbody> </table>			SEL	Pin control function	0	Z	1	反Z
SEL	Pin control function									
0	Z									
1	反Z									
PWR_EN	I,PL	Power enable. 0:Disable DC2DC and VCOM buffer, 1:enable DC2DC and VCOM buffer								
NBW	I,PL	Normally black or normally white setting. When NBW=H, Normally black When NBW=L, Normally white								
GMA_EN	I,PH	Internal Gamma enable 0: Enable internal Gamma, Gamma input voltage generated by internal circuit 1: Disable internal Gamma, V1~V14 Gamma input voltage								
GMA_SEL	I,PL	Gamma table select.								
VSET	I,PL	Gamma voltage input selection. 1: 10 gamma voltage input, V2, V6, V9, V13 is disable 0: V1~V14 gamma voltage input.								
TEST[29:0]	I/O	Test mode selection, for MP testing usage								
VDDA	P	Positive Power for source driver, connect to +13.5v (max.)								
VSSA	P	Analog ground								
VDD	P	Digital power input, range 2.3v ~ 3.6v								
VSS	P	Digital power ground								
VDDL	P	LVDS power input, range 2.3v ~ 3.6v								
VSSL	P	LVDS power ground								
DRVA	O	DC2DC output driver signal for the boost converter. (for VDDA)								
FBA	O	DC2DC output driver signal for the boost converter. (for VDDA)								

Designation	I/O	Description
DRVH	O	DC2DC output driver signal for the boost converter. (for VGH)
DRVL	O	DC2DC output driver signal for the boost converter. (for VGL)
DRVL_B	O	DC2DC output driver signal for the boost converter. (for VGL)
FBH	I	DC2DC controller feedback input (for VGH)
FBL	I	DC2DC controller feedback input (for VGL)
VCOMI	I	VCOM buffer in
VCOMO	O	VCOM buffer out
COM_PASSA COM_PASSB	S	Pass line for COM, internal link together between input side and output side
DUM_GND	SH	dummy pad, internal connect to ground.

NOTE :

I : Input ,O : Output, P : Power, D : Dummy, S : shorted line , M : mark, P : Power pad

T : Testing, SH : shielding, I/O : Input / Output, PS : Power Setting, C : Capacitor pin.

ORISE Tech Confidential
For 瑞达威 Use Only

Cascade Signal Description
4.1.1. Left side cascade signals

	MASL=1 GATELOC=0	MASL=1 GATELOC=1	MASL=0 GATELOC=0	MASL=0 GATELOC=1
Description	Master Mode Master on right	Master Mode Master on left	Slave Mode Master on right	Slave Mode Master on left
F_Ctrl_L	DAT0	F_Ctrl	X	DAT0
OEV_L	DAT1	OEV	X	DAT1
SYNC1_L	DAT2	XON	X	DAT2
SYNC2_L	DAT3	SYNC2	X	DAT3
UD_L	DAT4	UD	X	DAT4
CKV_L	DAT5	CKV	X	DAT5
STV2_L	DAT6	STV2	X	DAT6
STV1_L	DAT7	STV1	X	DAT7
STBN_L	DAT8	XON	X	DAT8

4.1.2. Right side cascade signals

	MASL=1 GATELOC =0	MASL=1 GATELOC =1	MASL=0 GATELOC =0	MASL=0 GATELOC =1
Description	Master Mode Master on right	Master Mode Master on left	Slave Mode Master on right	Slave Mode Master on left
F_Ctrl_R	F_Ctrl	DAT0	DAT0	X
OEV_R	OEV	DAT1	DAT1	X
SYNC1_R	XON	DAT2	DAT2	X
SYNC2_R	SYNC2	DAT3	DAT3	X
UD_R	UD	DAT4	DAT4	X
CKV_R	CKV	DAT5	DAT5	X
STV1_R	STV1	DAT6	DAT6	X
STV2_R	STV2	DAT7	DAT7	X
STBN_R	XON	DAT8	DAT8	X

4.2. Value of wiring resistance to each pin

The recommended wiring resistance values are shown below. The wiring resistance values affect the current capacity of the power supply, so be sure to design using values that do not exceed those recommended.

Pin Name	Wiring resistance value (Ω)	Pin Name	Wiring resistance value (Ω)
VDDA	<5	DRVA	<5
VDD	<10	FBA	<50
VDDL	<5	DRVH	<10
VSSA	<5	DRVL	<10
VSS	<10	DRVL_B	<10
VSSL	<5	GPM	<10
V1~V14	<200	GPMB	<10
D0/D1/D2[7:0]	<10	FBH	<50
HSYNC	<200	FBL	<50
VSYNC	<200	SDA	<200
DE	<200	SCL	<200
DCLK/DCLKN	<10	PWMIN	<200
VCOMI	<200	PWMOUT	<200
VCOMO	<5	Cascade signals	<200 & 20pf
CLKPOL			
RGBSWAP			
GMA_EN			
GMA_SEL			
RSTB			
STBYB			
MASL			
GATELOC			
RES[2:0]			
SHLR			
UPDN			
INFSEL	<1K		
DGEN			
CABCEN			
DITHB			
BIST			
MODE			
FRAME			
SEL			
PWR_EN			
NBW			
VSET			

5. FUNCTIONAL DESCRIPTIONS

5.1. Power On/Off Sequence

In order to prevent IC from power on reset fail, the rising time (T_{POR}) of the digital power supply VDD should be maintained within the given specifications. Refer to "AC Characteristics" for more detail on timing.

Power-On/Off Timing Sequence:

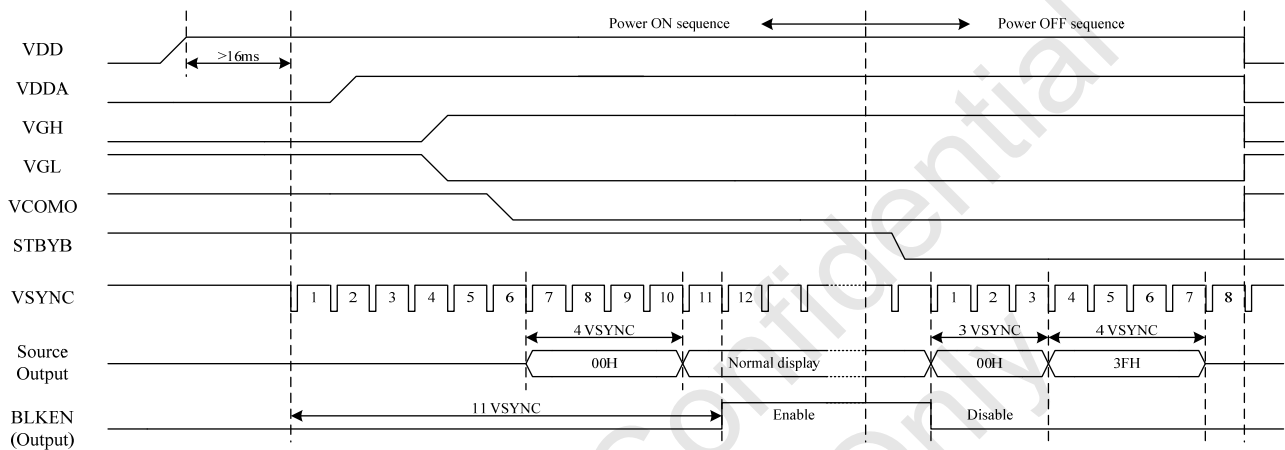

Enter and Exit Standby Mode Sequence:

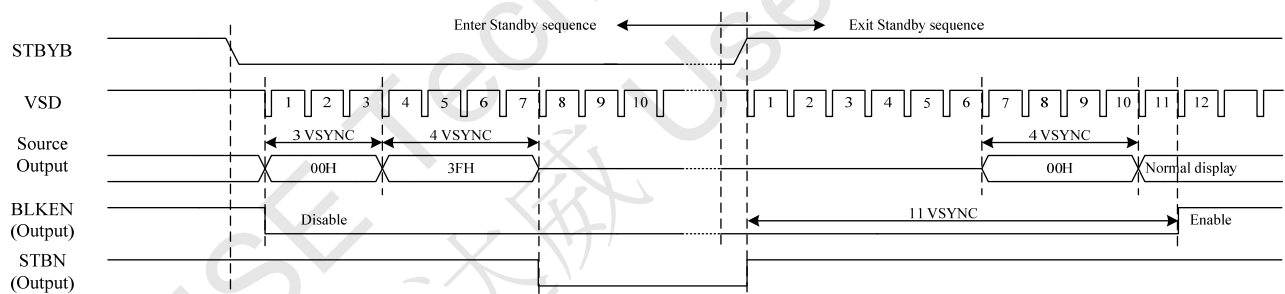

5.2. LVDS Data Mapping

The OTA7159A support LVDS interface input with NS data format.

NS data mapping:

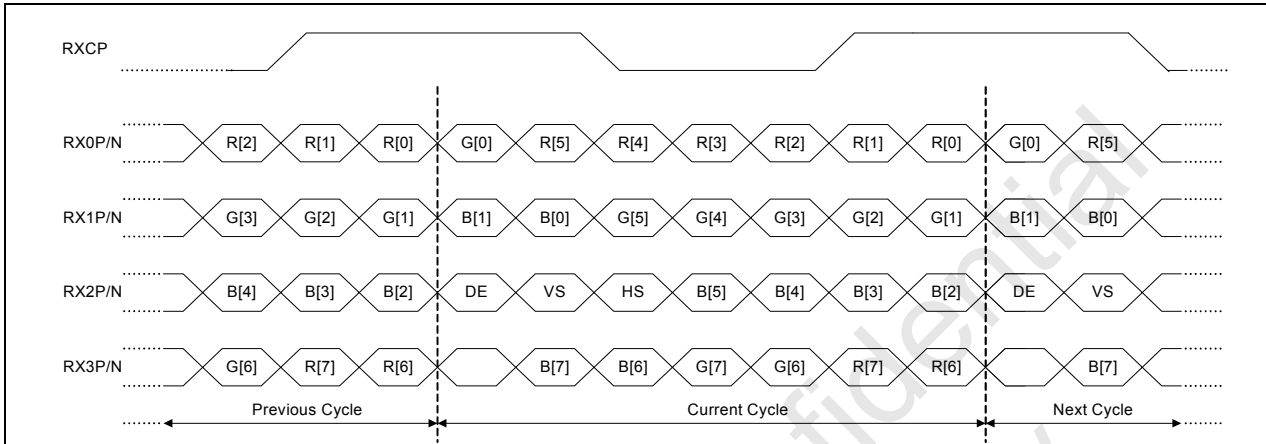

Note 1: For 6-Bit Mode, MSB are R/G/B [5] and R/G/B [0] are LSB

Note 2: For 8-Bit Mode, MSB are R/G/B [7] and R/G/B [0] are LSB

5.3. BIST function

When BIST = HIGH and no any input signals, the internal pattern generator activates and outputs the following self test patterns. These self test patterns show around 2 seconds.

5.3.1. BIST pattern

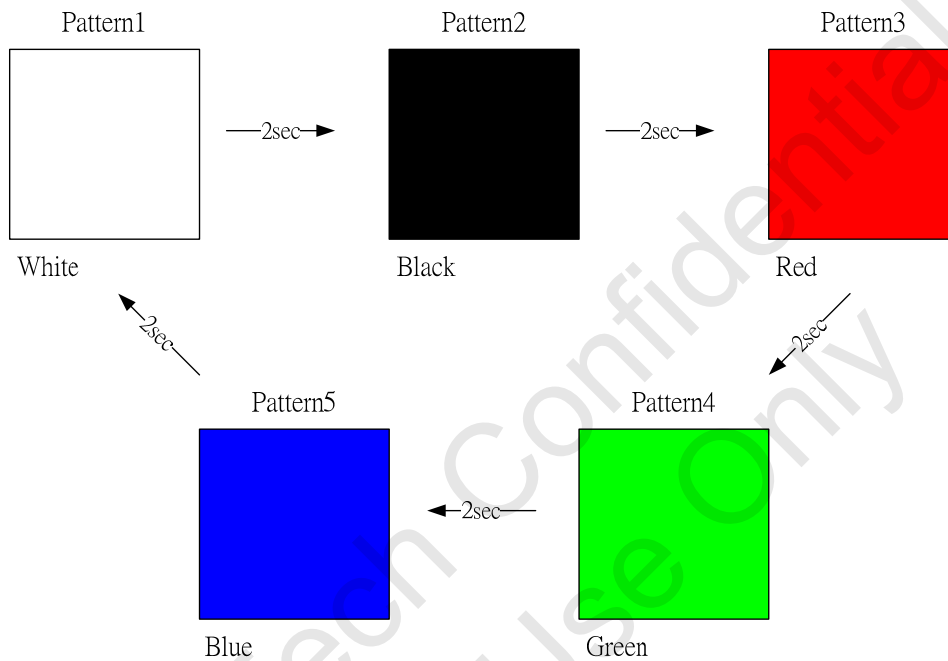

5.3.2. BIST Timing

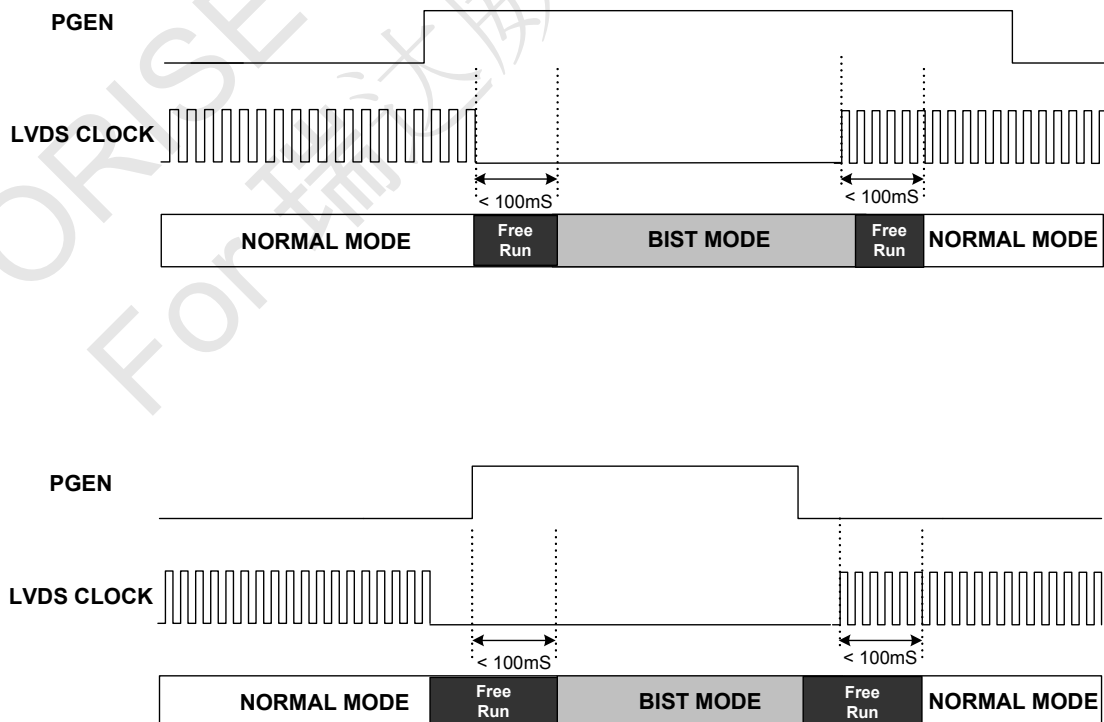

5.4. CABC architecture

The OTA7159A support CABC function with external or internal programmable gamma buffer. The interface between gamma buffer and OTA7159A is I2C.

5.5. TCON timing

5.5.1. Polarity control

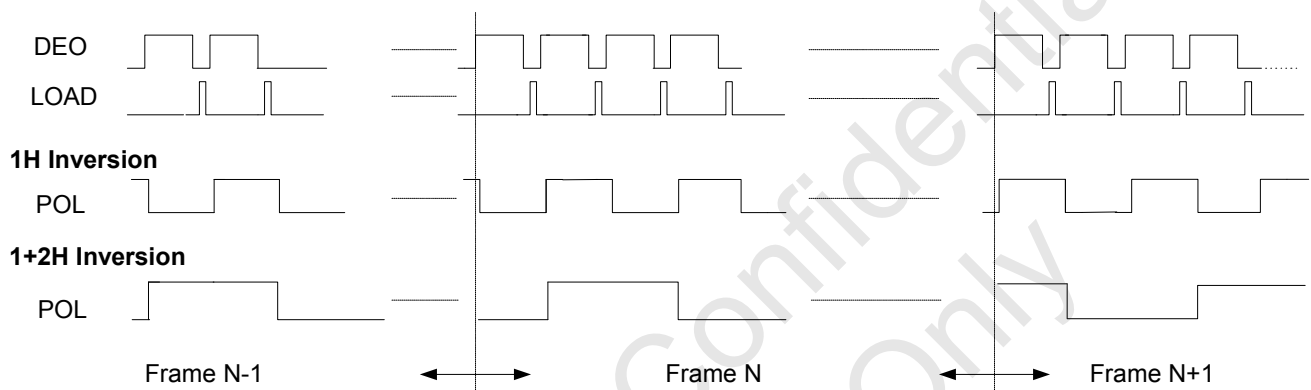

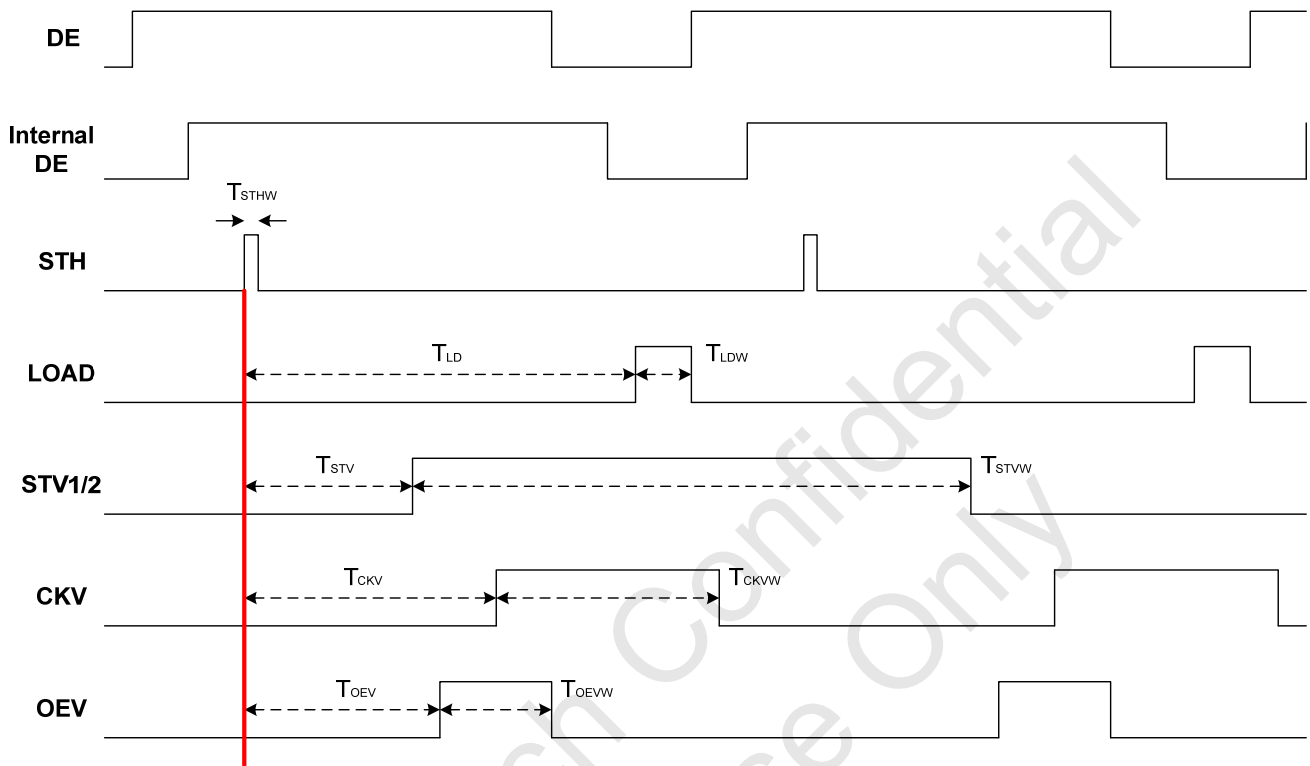
5.5.2. Gate driver timing (Single Gate)

	TLD	TLDW	TOEV	TOEVW	TCKV	TCKVW	TSTV	TSTVW	TSTHW	Unit
Default	TLD [9:0]	TLDW [9:0]	TOE1 [9:0]	TOE1W [9:0]	TCPV [9:0]	TCPVW [9:0]	TSTV [9:0]	TSTVW [9:0]	FIXED	Bit
XGA	TBD	TBD	TBD	TBD	TBD	TBD	TBD	1 LINE	1	T_{CLK}

Note: STH, LOAD and POL are internal signals inside OTA7159A

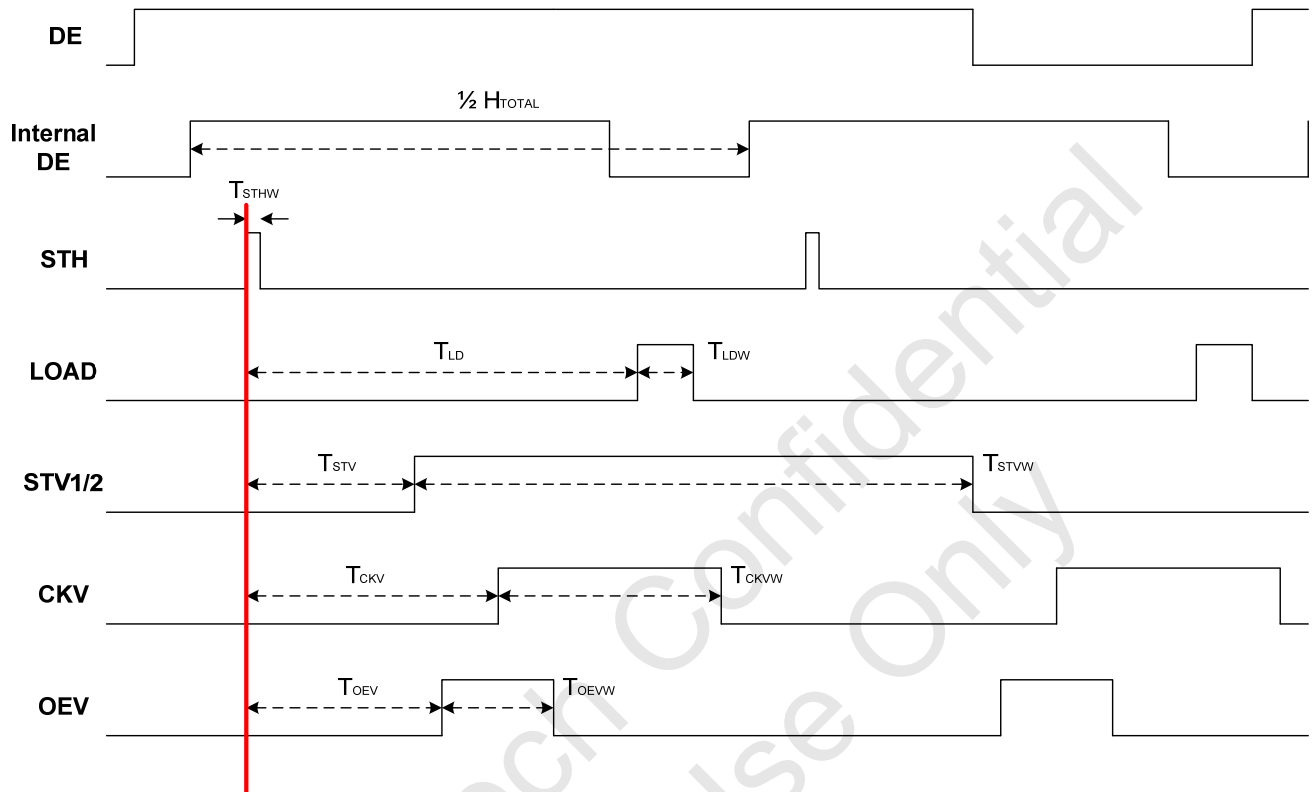
5.5.3. Gate driver timing (Dual Gate)

	TLD	TLDW	TOEV	TOEVW	TCKV	TCKVW	TSTV	TSTVW	TSTHW	Unit
Default	TLD [9:0]	TLDW [9:0]	TOE1 [9:0]	TOE1W [9:0]	TCPV [9:0]	TCPVW [9:0]	TSTV [9:0]	TSTVW [9:0]	FIXED	Bit
XGA	TBD	TBD	TBD	TBD	TBD	TBD	TBD	TBD	1 LINE	1 T_{CLK}

Note: STH, LOAD and POL are internal signals inside OTA7159A

5.6. Application Diagram

5.6.1. Cascade Application (DGEN=0), Gate IC on left (GATELOC=1), 1024 x 768 as example

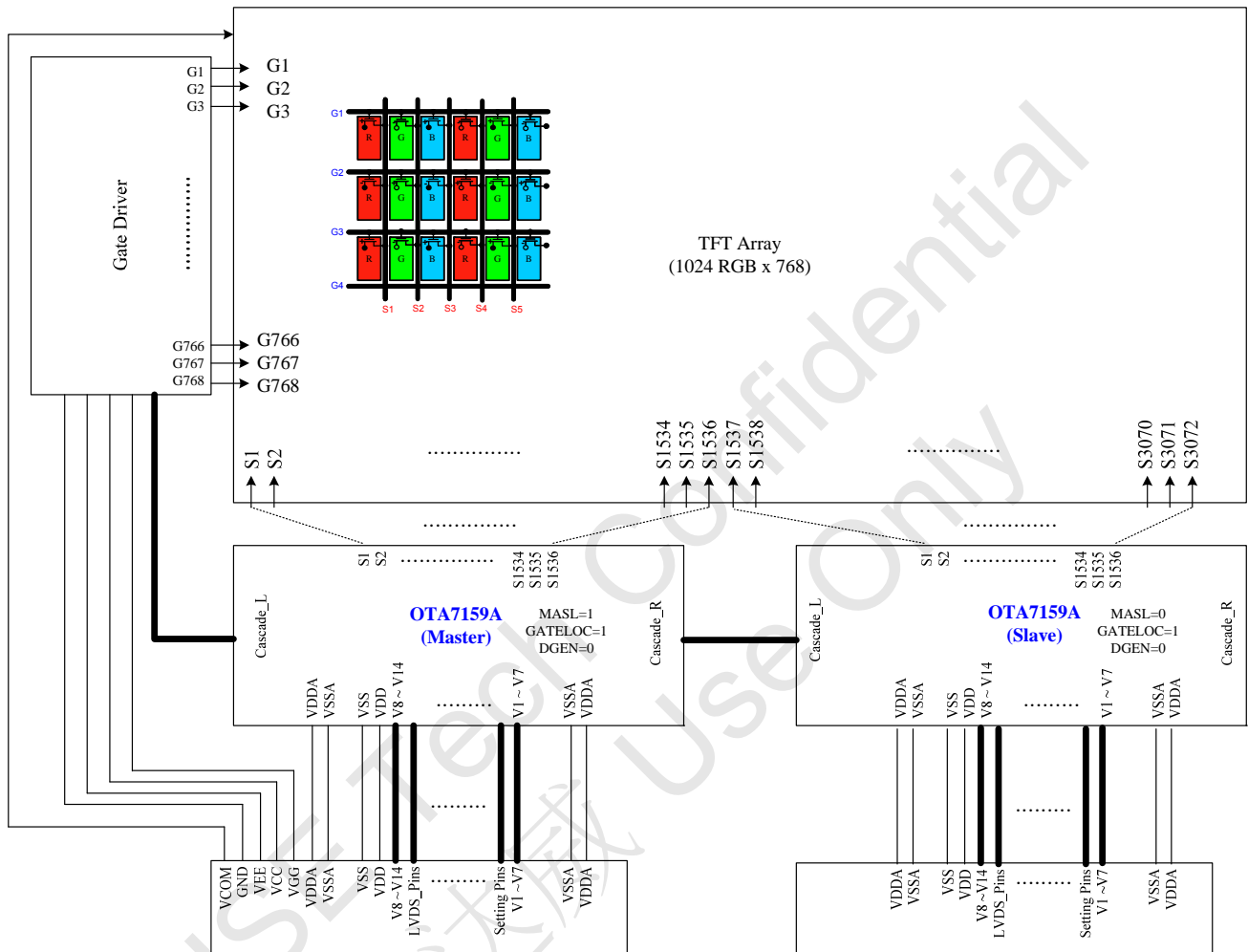

5.6.2. Cascade Application (DGEN=0), Gate IC on right (GATELOC=0), 1024 x 768 as example

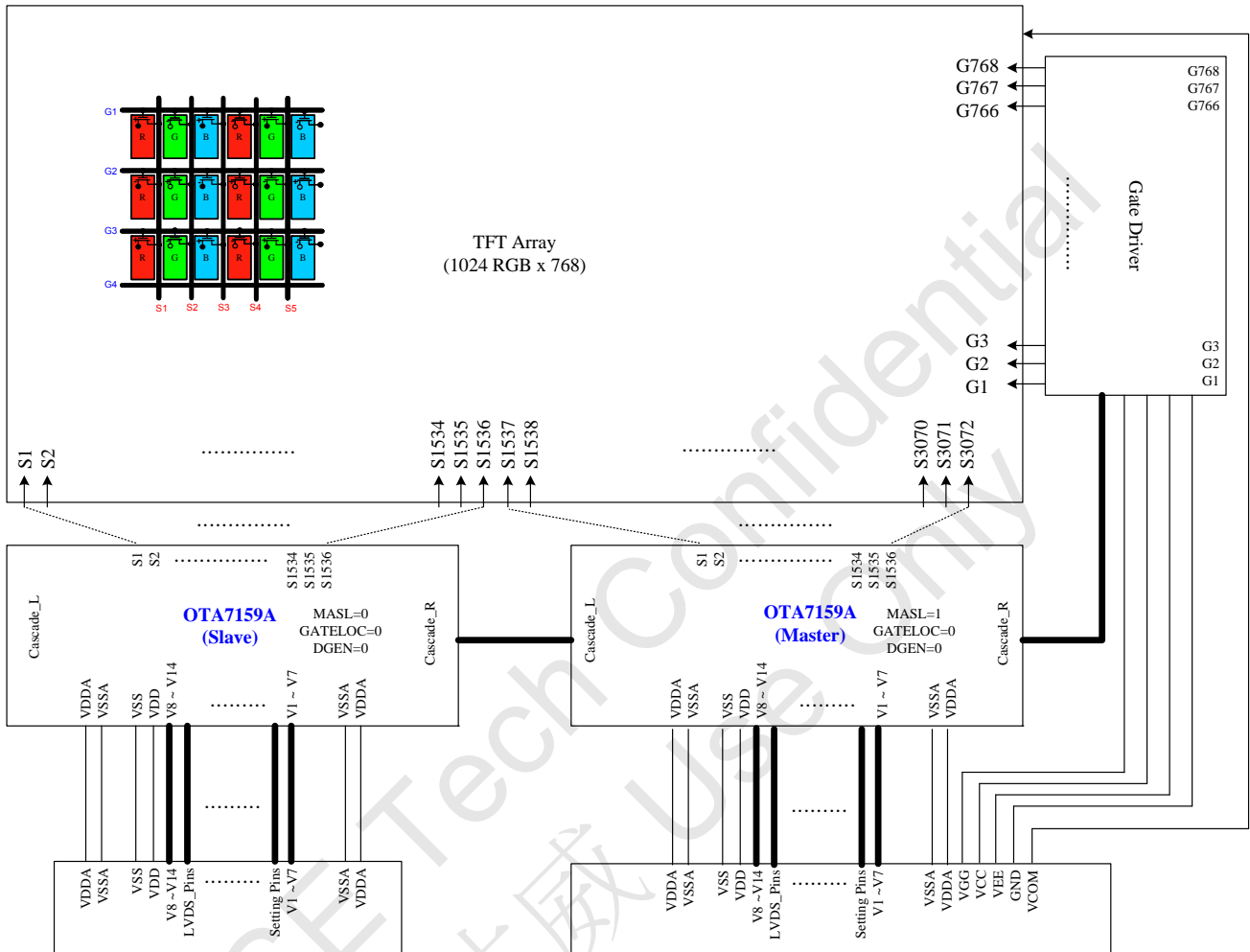

5.6.3. Dual Gate Application (DGEN=1) , Gate IC on left (GATELOC=1), 1024 x 600 as example

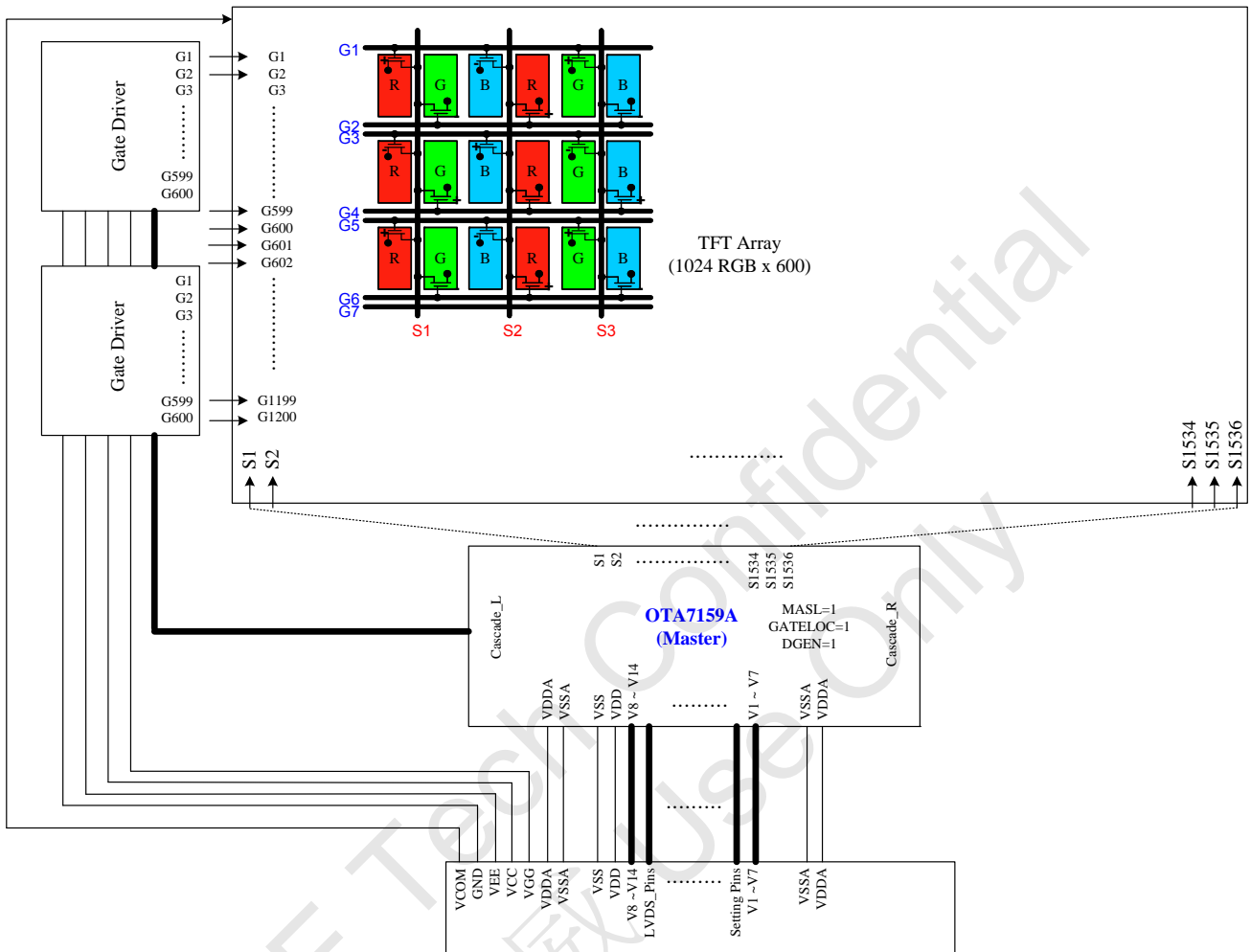

5.6.4. Dual Gate Application (DGEN=1), Gate IC on right (GATELOC=0), 1024 x 600 as example

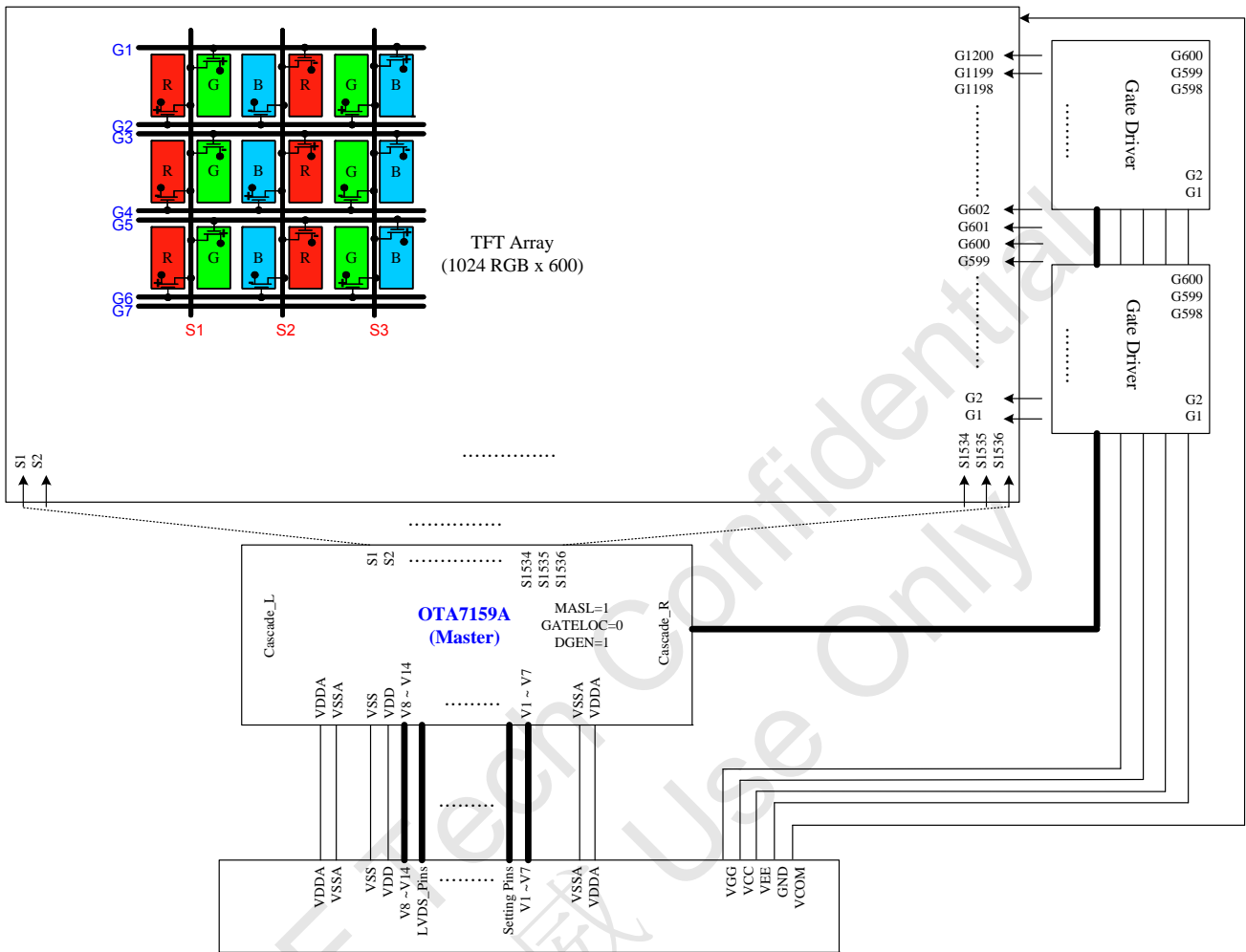

5.6.5. Power supply application circuit

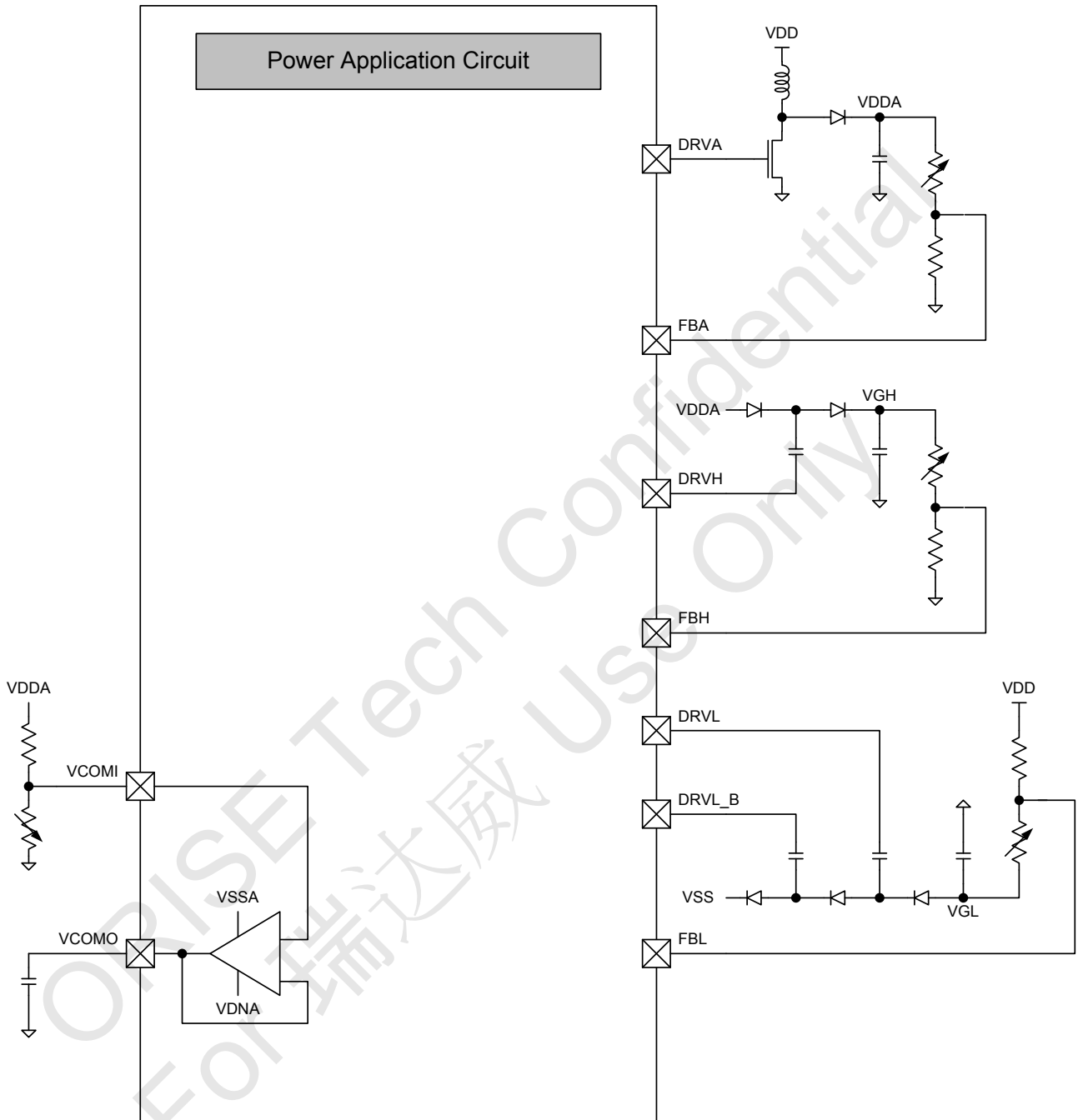

5.7. Useful & Useless Channel of Source Driver

RES1	RES0	Resolution	Useful channels #	Disable Channels
0	0	1024x600	1536ch	
0	1	1024x768	1536ch	
1	0	800x600	1200ch	S601 ~ S936
1	1	800x480	1200ch	S601 ~ S936

5.8. Input Data VS Output Voltage

The figure below shows the relationship between the input data and the output voltage. Refer to the following pages for the relative resistor values and voltage calculation method.

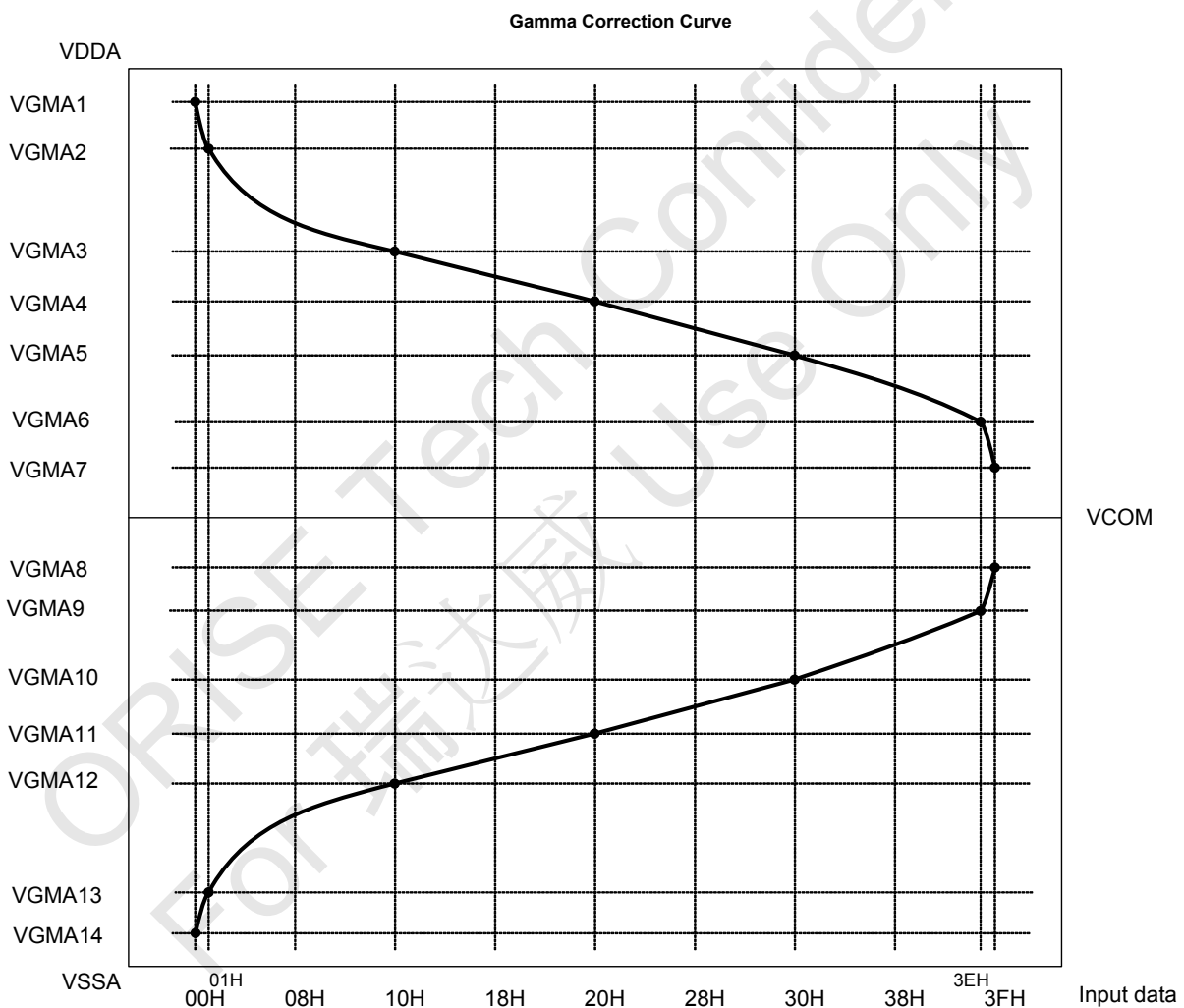

Remark: $VDDA-0.3 \geq VGMA1 \geq VGMA2 \geq VGMA3 \geq VGMA4 \geq VGMA5 \geq VGMA6 \geq VGMA7$;
 $VGMA8 \geq VGMA9 \geq VGMA10 \geq VGMA11 \geq VGMA12 \geq VGMA13 \geq VGMA14 \geq VSSA+0.3$

5.9. Gamma Correction Resistor Ratio

Name	Resistor
R0	10.48
R1	9.31
R2	8.15
R3	6.98
R4	5.82
R5	4.66
R6	3.88
R7	3.24
R8	2.81
R9	2.47
R10	2.21
R11	2.01
R12	1.81
R13	1.68
R14	1.59
R15	1.49
R16	1.38
R17	1.31
R18	1.24
R19	1.19
R20	1.14
R21	1.1
R22	1.05
R23	1.02
R24	0.99
R25	0.96
R26	0.93
R27	0.91
R28	0.89
R29	0.88
R30	0.86
R31	0.84

Name	Resistor
R32	0.83
R33	0.83
R34	0.82
R35	0.81
R36	0.81
R37	0.81
R38	0.81
R39	0.8
R40	0.8
R41	0.8
R42	0.81
R43	0.82
R44	0.83
R45	0.84
R46	0.85
R47	0.87
R48	0.88
R49	0.9
R50	0.93
R51	0.99
R52	1.02
R53	1.07
R54	1.17
R55	1.29
R56	1.41
R57	1.58
R58	1.79
R59	2.08
R60	2.59
R61	4.51
R62	35.72

5.10. Output Voltage vs. Input Data

	Positive polarity Output Voltage	Negative polarity Output Voltage
00H	V1	V14
01H	V1 + (V3-V1) X10.48 / 68.59	V14 + (V12-V14) X 10.48 / 68.59
02H	V1 + (V3-V1) X19.79 / 68.59	V14 + (V12-V14) X 19.79 / 68.59
03H	V1 + (V3-V1) X27.94 / 68.59	V14 + (V12-V14) X 27.94 / 68.59
04H	V1 + (V3-V1) X34.92 / 68.59	V14 + (V12-V14) X 34.92 / 68.59
05H	V1 + (V3-V1) X40.74 / 68.59	V14 + (V12-V14) X 40.74 / 68.59
06H	V1 + (V3-V1) X45.4 / 68.59	V14 + (V12-V14) X 45.4 / 68.59
07H	V1 + (V3-V1) X49.28 / 68.59	V14 + (V12-V14) X 49.28 / 68.59
08H	V1 + (V3-V1) X52.52 / 68.59	V14 + (V12-V14) X 52.52 / 68.59
09H	V1 + (V3-V1) X55.33 / 68.59	V14 + (V12-V14) X 55.33 / 68.59
0AH	V1 + (V3-V1) X57.8 / 68.59	V14 + (V12-V14) X 57.8 / 68.59
0BH	V1 + (V3-V1) X60.01 / 68.59	V14 + (V12-V14) X 60.01 / 68.59
0CH	V1 + (V3-V1) X62.02 / 68.59	V14 + (V12-V14) X 62.02 / 68.59
0DH	V1 + (V3-V1) X63.83 / 68.59	V14 + (V12-V14) X 63.83 / 68.59
0EH	V1 + (V3-V1) X65.51 / 68.59	V14 + (V12-V14) X 65.51 / 68.59
0FH	V1 + (V3-V1) X67.1 / 68.59	V14 + (V12-V14) X 67.1 / 68.59
10H	V3	V12
11H	V3 + (V4-V3) X 1.38 / 16.69	V12 + (V11-V12) X 1.38 / 16.69
12H	V3 + (V4-V3) X 2.69 / 16.69	V12 + (V11-V12) X 2.69 / 16.69
13H	V3 + (V4-V3) X 3.93 / 16.69	V12 + (V11-V12) X 3.93 / 16.69
14H	V3 + (V4-V3) X 5.12 / 16.69	V12 + (V11-V12) X 5.12 / 16.69
15H	V3 + (V4-V3) X 6.26 / 16.69	V12 + (V11-V12) X 6.26 / 16.69
16H	V3 + (V4-V3) X 7.36 / 16.69	V12 + (V11-V12) X 7.36 / 16.69
17H	V3 + (V4-V3) X 8.41 / 16.69	V12 + (V11-V12) X 8.41 / 16.69
18H	V3 + (V4-V3) X 9.43 / 16.69	V12 + (V11-V12) X 9.43 / 16.69
19H	V3 + (V4-V3) X 10.42 / 16.69	V12 + (V11-V12) X 10.42 / 16.69
1AH	V3 + (V4-V3) X 11.38 / 16.69	V12 + (V11-V12) X 11.38 / 16.69
1BH	V3 + (V4-V3) X 12.31 / 16.69	V12 + (V11-V12) X 12.31 / 16.69
1CH	V3 + (V4-V3) X 13.22 / 16.69	V12 + (V11-V12) X 13.22 / 16.69
1DH	V3 + (V4-V3) X 14.11 / 16.69	V12 + (V11-V12) X 14.11 / 16.69
1EH	V3 + (V4-V3) X 14.99 / 16.69	V12 + (V11-V12) X 14.99 / 16.69
1FH	V3 + (V4-V3) X 15.85 / 16.69	V12 + (V11-V12) X 15.85 / 16.69

	Positive polarity Output Voltage	Negative polarity Output Voltage
20H	V4	V11
21H	V4 + (V5-V4) X 0.83 / 13.14	V11 + (V10-V11) X 0.83 / 13.14
22H	V4 + (V5-V4) X 1.66 / 13.14	V11 + (V10-V11) X 1.66 / 13.14
23H	V4 + (V5-V4) X 2.48 / 13.14	V11 + (V10-V11) X 2.48 / 13.14
24H	V4 + (V5-V4) X 3.29 / 13.14	V11 + (V10-V11) X 3.29 / 13.14
25H	V4 + (V5-V4) X 4.1 / 13.14	V11 + (V10-V11) X 4.1 / 13.14
26H	V4 + (V5-V4) X 4.91 / 13.14	V11 + (V10-V11) X 4.91 / 13.14
27H	V4 + (V5-V4) X 5.72 / 13.14	V11 + (V10-V11) X 5.72 / 13.14
28H	V4 + (V5-V4) X 6.52 / 13.14	V11 + (V10-V11) X 6.52 / 13.14
29H	V4 + (V5-V4) X 7.32 / 13.14	V11 + (V10-V11) X 7.32 / 13.14
2AH	V4 + (V5-V4) X 8.12 / 13.14	V11 + (V10-V11) X 8.12 / 13.14
2BH	V4 + (V5-V4) X 8.93 / 13.14	V11 + (V10-V11) X 8.93 / 13.14
2CH	V4 + (V5-V4) X 9.75 / 13.14	V11 + (V10-V11) X 9.75 / 13.14
2DH	V4 + (V5-V4) X 10.58 / 13.14	V11 + (V10-V11) X 10.58 / 13.14
2EH	V4 + (V5-V4) X 11.42 / 13.14	V11 + (V10-V11) X 11.42 / 13.14
2FH	V4 + (V5-V4) X 12.27 / 13.14	V11 + (V10-V11) X 12.27 / 13.14
30H	V5	V10
31H	V5 + (V7-V5) X 0.88 / 57.93	V10 + (V8-V10) X 0.88 / 57.93
32H	V5 + (V7-V5) X 1.78 / 57.93	V10 + (V8-V10) X 1.78 / 57.93
33H	V5 + (V7-V5) X 2.71 / 57.93	V10 + (V8-V10) X 2.71 / 57.93
34H	V5 + (V7-V5) X 3.7 / 57.93	V10 + (V8-V10) X 3.7 / 57.93
35H	V5 + (V7-V5) X 4.72 / 57.93	V10 + (V8-V10) X 4.72 / 57.93
36H	V5 + (V7-V5) X 5.79 / 57.93	V10 + (V8-V10) X 5.79 / 57.93
37H	V5 + (V7-V5) X 6.96 / 57.93	V10 + (V8-V10) X 6.96 / 57.93
38H	V5 + (V7-V5) X 8.25 / 57.93	V10 + (V8-V10) X 8.25 / 57.93
39H	V5 + (V7-V5) X 9.66 / 57.93	V10 + (V8-V10) X 9.66 / 57.93
3AH	V5 + (V7-V5) X 11.24 / 57.93	V10 + (V8-V10) X 11.24 / 57.93
3BH	V5 + (V7-V5) X 13.03 / 57.93	V10 + (V8-V10) X 13.03 / 57.93
3CH	V5 + (V7-V5) X 15.11 / 57.93	V10 + (V8-V10) X 15.11 / 57.93
3DH	V5 + (V7-V5) X 17.7 / 57.93	V10 + (V8-V10) X 17.7 / 57.93
3EH	V5 + (V7-V5) X 22.21 / 57.93	V10 + (V8-V10) X 22.21 / 57.93
3FH	V7	V8

6. ELECTRICAL SPECIFICATIONS

6.1. Absolute Maximum Ratings

VOLTAGE

(GND = AGND = 0V, TA=25°C)

	MIN	MAX	UNIT
Digital Supply Voltage, VDD	-0.5	4v	V
Analog Supply Voltage, AVDD,V1~V14	-0.5	15v	V

Note1 : The maximum applicable voltage on any pin is respected to 0V.

Note2 : Device is subject to be damaged permanently if stresses beyond those absolute maximum ratings listed above.

TEMPERATURE

	MIN	MAX	UNIT
Operating temperature	-20	85	°C
Storage temperature	-55	125	°C

*Comments

Stresses above those listed under "Absolute Maximum Ratings" may cause permanent damage to the device.

These are stress ratings only. Functional operation of this device at these or any other conditions above those

Indicated in the operational sections of this specification is not implied and exposed to absolute maximum rating

Conditions for extended periods may affect reliability.

6.2. Recommended Operating Conditions

(GND = AGND = 0V, TA= -20 to +85°C)

Parameter	Symbol	MIN.	Typ.	MAX.	UNIT
Digital supply voltage	VDD	2.3	-	3.6	V
LVDS supply voltage	VDDL	2.3	-	3.6	V
Analog supply voltage	VDDA	6.5	-	13.5	V

6.3. DC Characteristics
6.3.1. System characteristics

(VDD=3.3V, VDPA=5V, VDPA=-5V, GND=AGND=0V, TA=-20 to +85°C)

Parameter	Symbol	MIN.	Typ.	MAX.	UNIT	Conditions
Input low voltage level	Vil	0	-	0.3*VDD	V	For digital I/O
Input high voltage level	Vih	0.7*VDD	-	VDD	V	For digital I/O
Input leakage current	Ii	-	-	+/- 1uA	μA	For digital I/O
Output high voltage level	Voh	0.8*VDD	-	-	V	For digital I/O, Ioh = 400uA
Output low voltage level	Vol	-	-	0.2*VDD	V	For digital I/O, Iol = 400uA
Pull low/high resistor	Ri	200K	250K	300K	ohm	For digital I/O
Digital Operation current	Idd	-	TBD	-	mA	
Digital Stand-by current	Ist1	-	TBD	-	μA	
Analog Operation current	Idda	-	TBD	-	mA	
Analog Stand-by current	Ist2	-	TBD	-	μA	
Input level of V1 ~ V7	Vref1	VDDA/2+0.3	-	VDDA-0.3	V	Gamma positive voltage input
Input level of V8 ~ V14	Vref2	0.3	-	VDDA/2-0.3	V	Gamma negative voltage input
Output Voltage deviation	Vod1	-	+/- 20	+/- 35	mV	Vso=VDDA-0.1 ~ VDDA-0.5 & Vso=0.1 ~ 0.5
Output Voltage deviation	Vod2	-	+/- 15	+/- 20	mV	Vso=0.5 ~ VDDA-0.5
Output Voltage offset Between Chips	Voc	-	-	+/- 20	mV	Vso=0.5 ~ VDDA-0.5
Dynamic Range of Output	Vdr	0.3	-	VDDA-0.3	V	S1 ~ S1536
Sinking Current of Outputs	IOLy	80	-	-	μA	S1 ~ S1536
Driving Current of Outputs	IOHy	80	-	-	μA	S1 ~ S1536
Resistance of Gamma Table	Rg	0.7*Rn	Rn	1.3*Rn	ohm	Assume internal resistor Rn

6.3.2. LVDS DC characteristics

TBD

6.4. LVDS DC characteristics

Parameter	Symbol	Min.	Typ.	Max	Unit	Conditions
Differential Input High Threshold	V _{TH}	-	-	100	mV	V _{CM} =+1.2V
Differential Input Low Threshold	V _{TL}	-100	-	-	mV	
Average Supply Current	I _{CC}	-	TBD	-	mA	CLK=65MHz

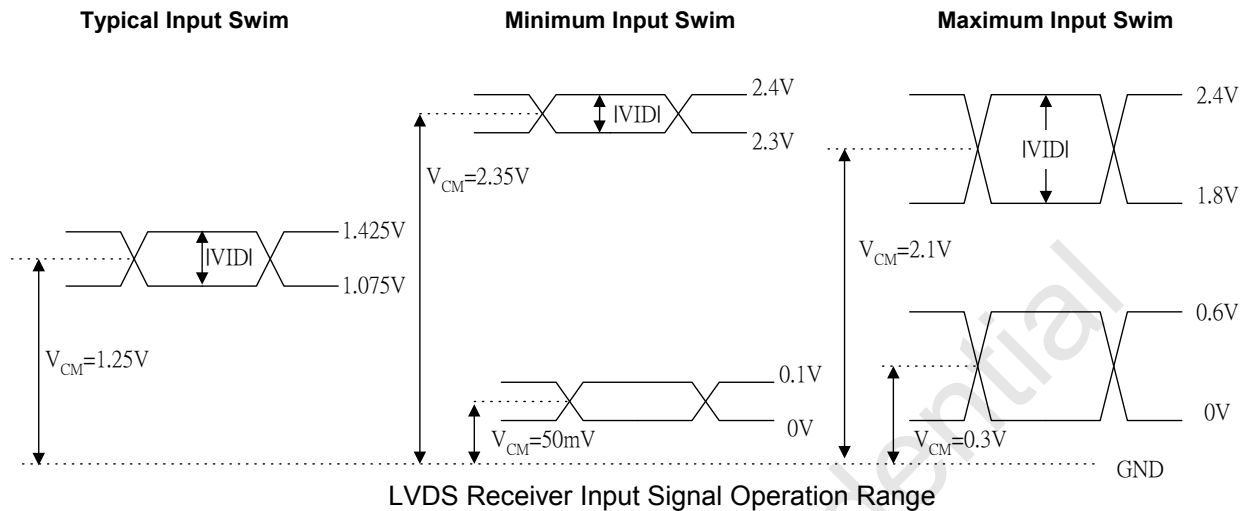

6.5. AC Characteristics

6.5.1. System AC characteristics

(VDD=3.3V, VDDA=13.5V, VSS=VSSA=0V, TA=-20 to +85°C)

Parameter	Symbol	MIN.	Typ.	MAX.	UNIT	Conditions
VDD Power On Slew rate	T	-	-	20	ms	From GND to 90% VDD
RSTB pulse width	T	10	-	-	us	

6.5.2. Parallel RGB AC characteristics

(VDD=3.3V, VDDA=13.5V, VSS=VSSA=0V, TA=-20 to +85°C)

Parameter	Symbol	MIN.	Typ.	MAX.	UNIT	Conditions
DCLK Frequency	Fclk	-	-	50	MHz	
DCLK Cycle Time	Tclk	20	-	-	ns	
DCLK Pulse Duty	Tcwh	45	50	55	%	
VSYNC setup time	Tvst	8	-	-	ns	
VSYNC hold time	Tvhd	8	-	-	ns	
HSYNC setup time	Thst	8	-	-	ns	
HSYNC hold time	Thhd	8	-	-	ns	
Data set-up time	Tdsu	8	-	-	ns	
Data hold time	Tdhd	8	-	-	ns	
DE set-up time	Tesu	8	-	-	ns	
DE hold time	Tehd	8	-	-	ns	
Output stable time	Tsst	-	-	6	us	10% to 90% target voltage. CL=120pF, R=10k ohm.

6.5.3. LVDS AC characteristics

(VDD=3.3V, VDDA=13.5V, VSS=VSSA=0V, TA=-20 to +85°C)

Parameter	Symbol	Min.	Typ.	Max	Unit	Conditions
Operating Frequency range	F _{OP}	40	-	90	MHz	
Receiver Skew Margin	R _{SKM}	-	-	450	ps	LVDS clock = 85MHz, 100mV LVDS signal
Pick-to-pick Jitter Tolerance (Note1)	T _{JIT}	2.0	-	-	ns	
Receiver startup time (after a valid LVDS clock is applied)	T _{STRAT}	-	-	10	ms	LVDS clock = 85MHz, 100mV LVDS signal
Input capacitance of LVDS pins	C _{IN}	-	7.0	-	pF	

Note1: Jitter tolerance is a system level tolerance test. It involves applying jitter to the input clock of an LVDS transmitter and monitoring the resulting bit error rate for the link. Different jitter frequencies are tested, up to 10 MHz. The jitter shown is an accumulated jitter.

ORISE Tech Confidential
For 瑞达威 Use Only

Timing Diagram

Input Clock and Data Timing Diagram

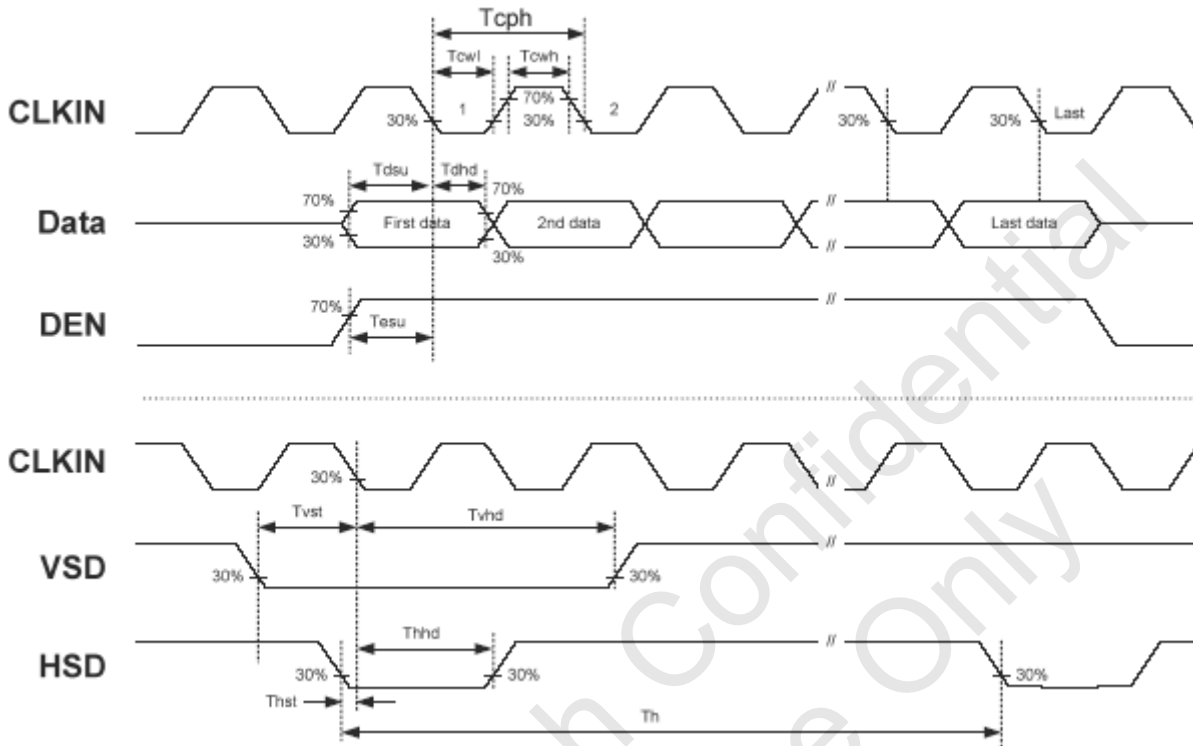

Source Output Timing Diagram (Cascade)

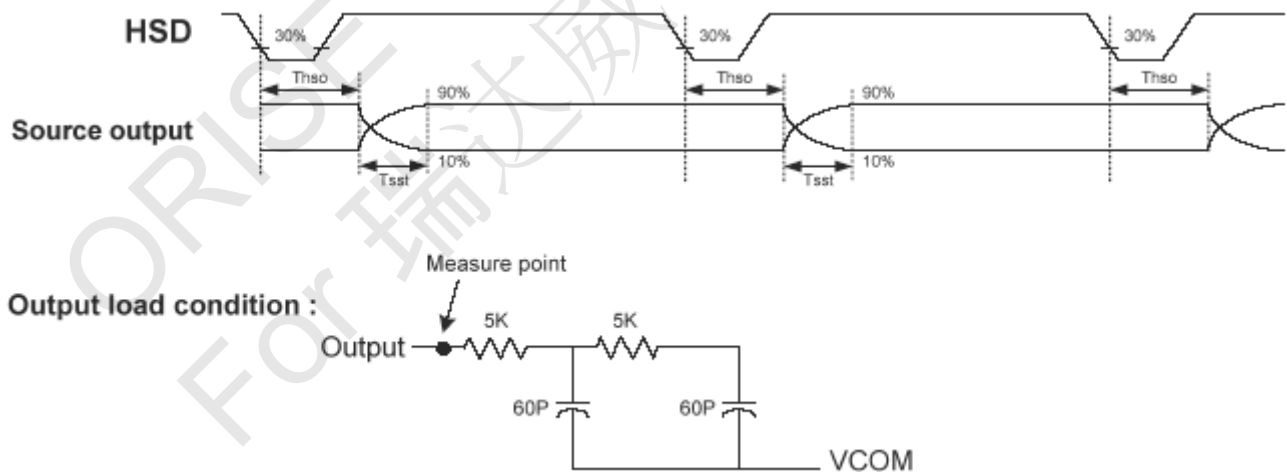

Vertical Timing Diagram HV (Cascade)

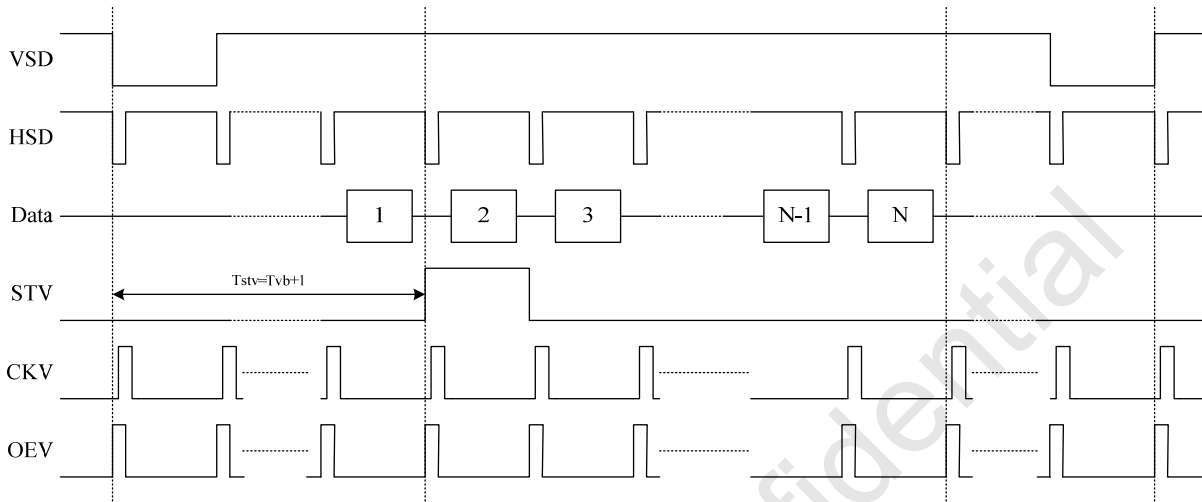

Vertical Timing Diagram DE (Cascade)

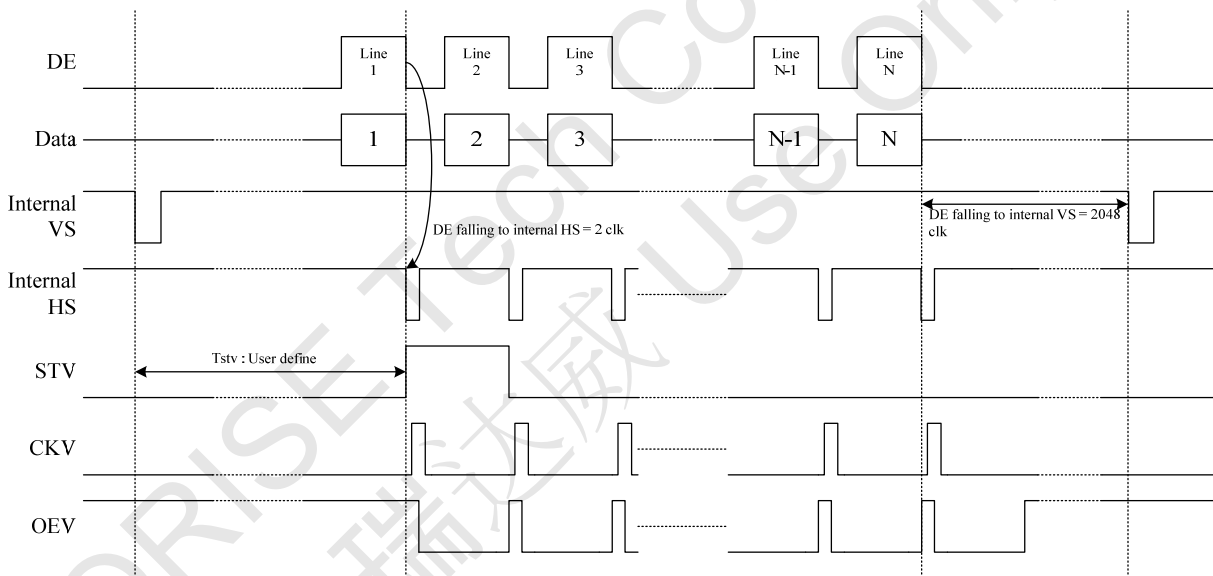

Gate output timing diagram (Cascade)

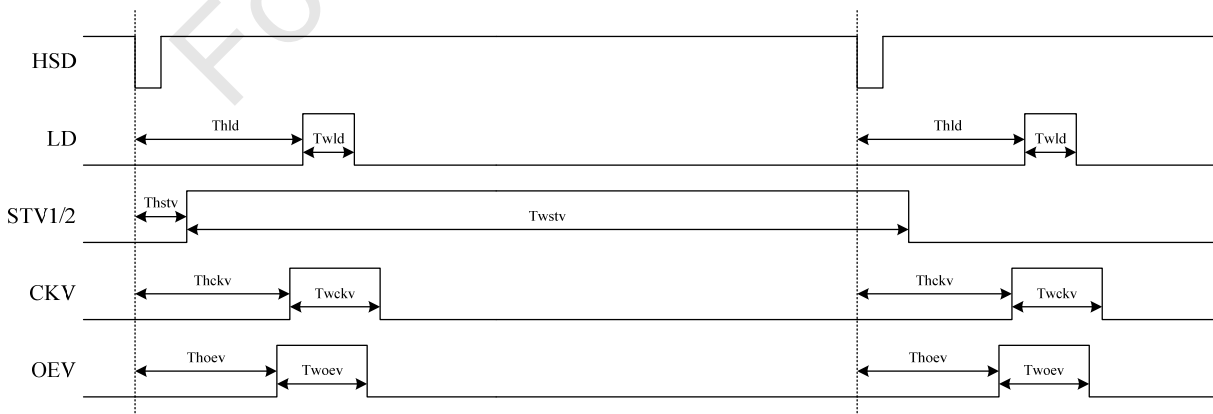

Vertical Timing Diagram HV (Dual Gate)

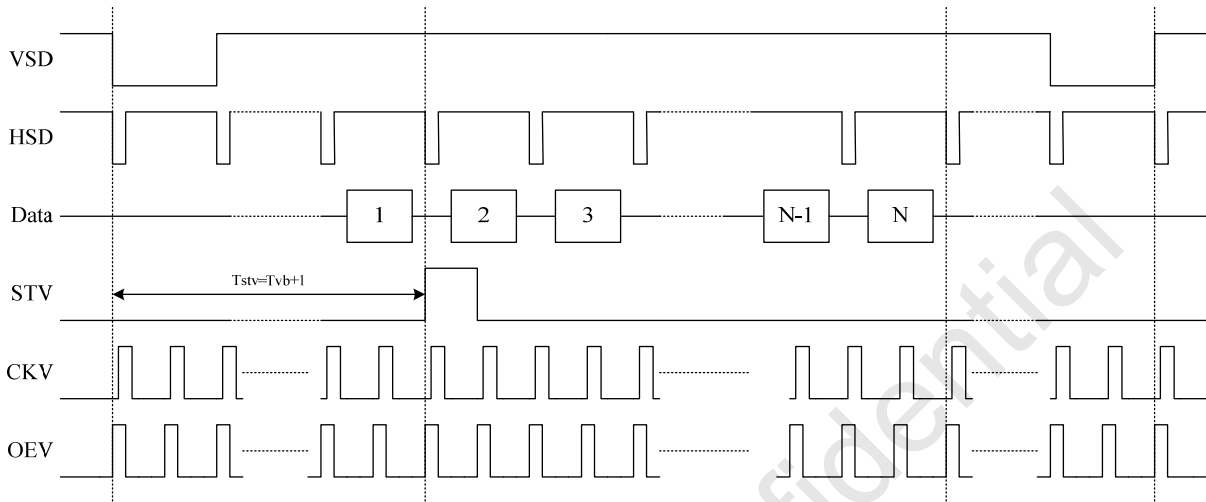

Vertical Timing Diagram DE (Dual Gate)

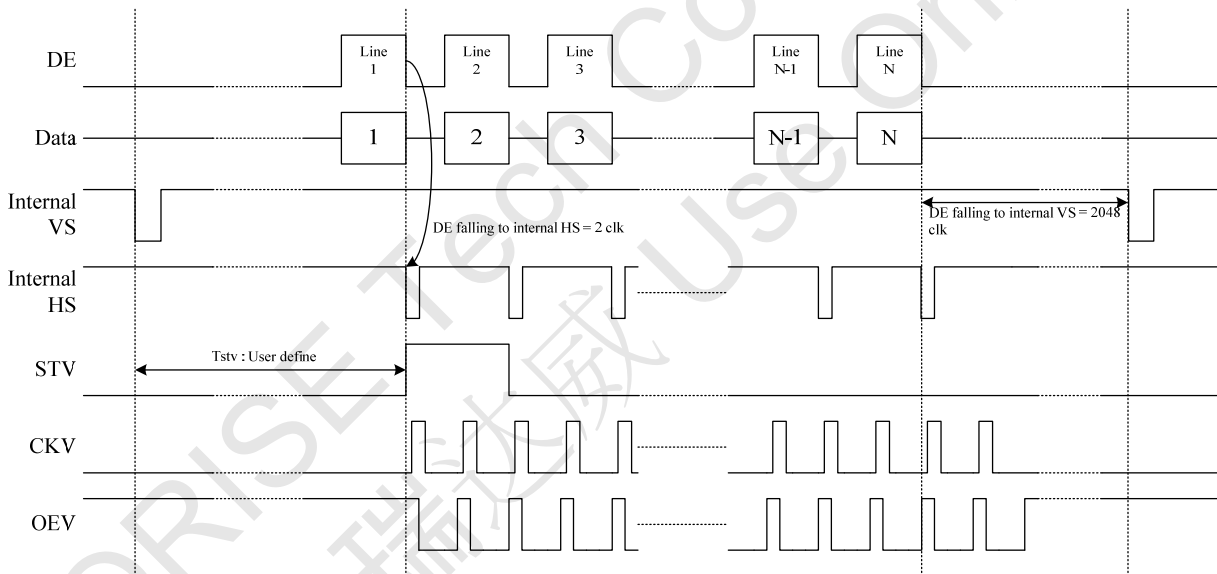

Gate output timing diagram (Dual Gate)

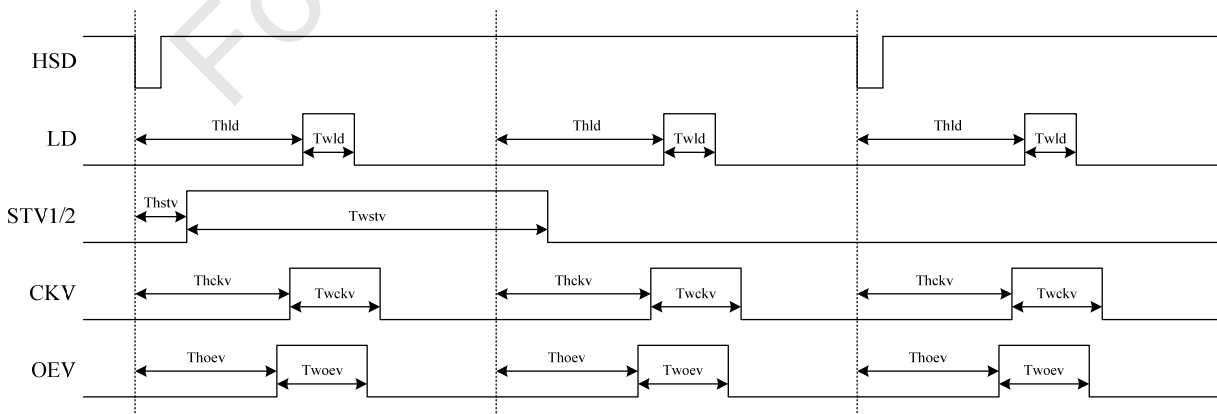

7. CHIP INFORMATION

7.1. PAD Assignment

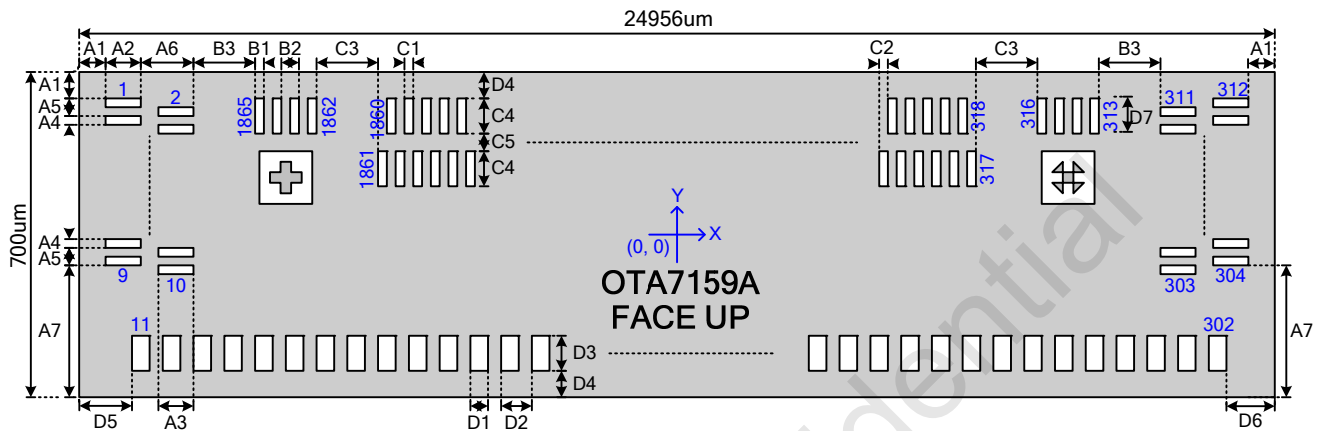

Note1: Chip size included scribe line.

Note2: Have Temperature compensation design.

Symbol	Size	Symbol	Size	Symbol	Size	Symbol	Size	Symbol	Size
A1	48	A6	100	C1	15	D1	65	D6	88
A2	67	A7	293	C2	15	D2	85	D7	70
A3	80	B1	30	C3	20	D3	100	Unit: um	
A4	30	B2	50	C4	100	D4	57		
A5	80	B3	43	C5	30	D5	68		

7.2. PAD Dimension

Item	PAD No.	Size		Unit
		X	Y	
Chip Size	-	24956	700	μm
Chip thickness	-	300 ± 20		
Pad pitch	11-302	85	-	
	1,3,5,7,9,304,306,308,310,311	-	80	
	2,4,6,8,10,303,305,307,309,312	-	80	
	313-316, 1862-1865	50	-	
	317-1861	15	130	
Pad size	11-302	65	100	
	1,3,5,7,9,304,306,308,310,311	67	30	
	2,4,6,8,10,303,305,307,309,312	80	30	
	313-316, 1862-1865	30	70	
	317-1861	15	100	

Note1: Chip size included scribe line.

7.3. Pad Location

NO.	PAD NAME	X	Y
1	F_Ctrl_R	-12396.5	278
2	OEV_R	-12303	238
3	SYNC1_R	-12396.5	198
4	SYNC2_R	-12303	158
5	UD_R	-12396.5	118
6	CKV_R	-12303	78
7	STV2_R	-12396.5	38
8	STV1_R	-12303	-2
9	F_Ctrl_R	-12396.5	-42
10	STBN_R	-12303	-82
11	COM_PASSB	-12377.5	-243
12	COM_PASSB	-12292.5	-243
13	TEST0	-12207.5	-243
14	TEST1	-12122.5	-243
15	TEST2	-12037.5	-243
16	TEST3	-11952.5	-243
17	DUM_GND	-11867.5	-243
18	VSSA	-11782.5	-243
19	VSSA	-11697.5	-243
20	VSSA	-11612.5	-243
21	VSSA	-11527.5	-243
22	DUM_GND	-11442.5	-243
23	VDDA	-11357.5	-243
24	VDDA	-11272.5	-243
25	VDDA	-11187.5	-243
26	VDDA	-11102.5	-243
27	DUM_GND	-11017.5	-243
28	VSS	-10932.5	-243
29	VSS	-10847.5	-243
30	VSS	-10762.5	-243
31	VSS	-10677.5	-243
32	DUM_GND	-10592.5	-243
33	VDD	-10507.5	-243
34	VDD	-10422.5	-243
35	VDD	-10337.5	-243
36	VDD	-10252.5	-243
37	DUM_GND	-10167.5	-243
38	TEST4	-10082.5	-243
39	TEST5	-9997.5	-243
40	TEST6	-9912.5	-243
41	TEST7	-9827.5	-243
42	TEST8	-9742.5	-243
43	TEST9	-9657.5	-243
44	TEST10	-9572.5	-243
45	TEST11	-9487.5	-243
46	TEST12	-9402.5	-243
47	TEST13	-9317.5	-243
48	DUM_GND	-9232.5	-243
49	PWMIN	-9147.5	-243
50	PWMIN	-9062.5	-243
51	NBW	-8977.5	-243
52	NBW	-8892.5	-243
53	PINCTRL	-8807.5	-243
54	PINCTRL	-8722.5	-243
55	DUM_GND	-8637.5	-243

NO.	PAD NAME	X	Y
56	PWMOUT	-8552.5	-243
57	PWMOUT	-8467.5	-243
58	DUM_GND	-8382.5	-243
59	DITHER	-8297.5	-243
60	DITHER	-8212.5	-243
61	HFRC	-8127.5	-243
62	HFRC	-8042.5	-243
63	TEST14	-7957.5	-243
64	TEST15	-7872.5	-243
65	FRAME	-7787.5	-243
66	FRAME	-7702.5	-243
67	SEL	-7617.5	-243
68	SEL	-7532.5	-243
69	GMA_SEL	-7447.5	-243
70	GMA_SEL	-7362.5	-243
71	CSB	-7277.5	-243
72	CSB	-7192.5	-243
73	DUM_GND	-7107.5	-243
74	SDA	-7022.5	-243
75	SDA	-6937.5	-243
76	DUM_GND	-6852.5	-243
77	SCL	-6767.5	-243
78	SCL	-6682.5	-243
79	DUM_GND	-6597.5	-243
80	VDD	-6512.5	-243
81	VDD	-6427.5	-243
82	VDD	-6342.5	-243
83	VDD	-6257.5	-243
84	DUM_GND	-6172.5	-243
85	VSS	-6087.5	-243
86	VSS	-6002.5	-243
87	VSS	-5917.5	-243
88	VSS	-5832.5	-243
89	DUM_GND	-5747.5	-243
90	VDDA	-5662.5	-243
91	VDDA	-5577.5	-243
92	VDDA	-5492.5	-243
93	VDDA	-5407.5	-243
94	DUM_GND	-5322.5	-243
95	VSSA	-5237.5	-243
96	VSSA	-5152.5	-243
97	VSSA	-5067.5	-243
98	VSSA	-4982.5	-243
99	DUM_GND	-4897.5	-243
100	V1	-4812.5	-243
101	V1	-4727.5	-243
102	V2	-4642.5	-243
103	V2	-4557.5	-243
104	V3	-4472.5	-243
105	V3	-4387.5	-243
106	V4	-4302.5	-243
107	V4	-4217.5	-243
108	V5	-4132.5	-243
109	V5	-4047.5	-243
110	V6	-3962.5	-243

NO.	PAD NAME	X	Y
111	V6	-3877.5	-243
112	V7	-3792.5	-243
113	V7	-3707.5	-243
114	DUM	-3622.5	-243
115	DUM	-3537.5	-243
116	DUM_GND	-3452.5	-243
117	DUM_GND	-3367.5	-243
118	VSYNC	-3282.5	-243
119	DUM_GND	-3197.5	-243
120	HSYNC	-3112.5	-243
121	DUM_GND	-3027.5	-243
122	DE	-2942.5	-243
123	VSSL	-2857.5	-243
124	VSSL	-2772.5	-243
125	VSSL	-2687.5	-243
126	VSSL	-2602.5	-243
127	D27	-2517.5	-243
128	D26	-2432.5	-243
129	DUM_GND	-2347.5	-243
130	D25	-2262.5	-243
131	D24	-2177.5	-243
132	DUM_GND	-2092.5	-243
133	D23	-2007.5	-243
134	D22	-1922.5	-243
135	DUM_GND	-1837.5	-243
136	D21	-1752.5	-243
137	D20	-1667.5	-243
138	DUM_GND	-1582.5	-243
139	DCLK	-1497.5	-243
140	DCLKN	-1412.5	-243
141	DUM_GND	-1327.5	-243
142	VDDL	-1242.5	-243
143	VDDL	-1157.5	-243
144	VDDL	-1072.5	-243
145	VDDL	-987.5	-243
146	REV	-902.5	-243
147	DUM_GND	-817.5	-243
148	D17	-732.5	-243
149	D16	-647.5	-243
150	DUM_GND	-562.5	-243
151	D15	-477.5	-243
152	D14	-392.5	-243
153	DUM_GND	-307.5	-243
154	D13	-222.5	-243
155	D12	-137.5	-243
156	DUM_GND	-52.5	-243
157	D11	32.5	-243
158	D10	117.5	-243
159	DUM_GND	202.5	-243
160	D07	287.5	-243
161	D06	372.5	-243
162	DUM_GND	457.5	-243
163	D05	542.5	-243
164	D04	627.5	-243
165	DUM_GND	712.5	-243

NO.	PAD NAME	X	Y
166	D03	797.5	-243
167	D02	882.5	-243
168	DUM_GND	967.5	-243
169	D01	1052.5	-243
170	D00	1137.5	-243
171	DUM_GND	1222.5	-243
172	DUM_GND	1307.5	-243
173	GMA_EN	1392.5	-243
174	GMA_EN	1477.5	-243
175	V8	1562.5	-243
176	V8	1647.5	-243
177	V9	1732.5	-243
178	V9	1817.5	-243
179	V10	1902.5	-243
180	V10	1987.5	-243
181	V11	2072.5	-243
182	V11	2157.5	-243
183	V12	2242.5	-243
184	V12	2327.5	-243
185	V13	2412.5	-243
186	V13	2497.5	-243
187	V14	2582.5	-243
188	V14	2667.5	-243
189	DUM_GND	2752.5	-243
190	VSSA	2837.5	-243
191	VSSA	2922.5	-243
192	VSSA	3007.5	-243
193	VSSA	3092.5	-243
194	DUM_GND	3177.5	-243
195	VDDA	3262.5	-243
196	VDDA	3347.5	-243
197	VDDA	3432.5	-243
198	VDDA	3517.5	-243
199	DUM_GND	3602.5	-243
200	VSS	3687.5	-243
201	VSS	3772.5	-243
202	VSS	3857.5	-243
203	VSS	3942.5	-243
204	DUM_GND	4027.5	-243
205	VDD	4112.5	-243
206	VDD	4197.5	-243
207	VDD	4282.5	-243
208	VDD	4367.5	-243
209	DUM_GND	4452.5	-243
210	DGEN	4537.5	-243
211	DGEN	4622.5	-243
212	MASL	4707.5	-243
213	MASL	4792.5	-243
214	GATELOC	4877.5	-243
215	GATELOC	4962.5	-243
216	CABCEN	5047.5	-243
217	CABCEN	5132.5	-243
218	VSET	5217.5	-243
219	VSET	5302.5	-243
220	DUM	5387.5	-243
221	DUM	5472.5	-243
222	MODE	5557.5	-243

NO.	PAD NAME	X	Y
223	MODE	5642.5	-243
224	INFSEL	5727.5	-243
225	INFSEL	5812.5	-243
226	BIST	5897.5	-243
227	BIST	5982.5	-243
228	RES0	6067.5	-243
229	RES0	6152.5	-243
230	RES1	6237.5	-243
231	RES1	6322.5	-243
232	CLKPOL	6407.5	-243
233	CLKPOL	6492.5	-243
234	STBYB	6577.5	-243
235	STBYB	6662.5	-243
236	RSTB	6747.5	-243
237	RSTB	6832.5	-243
238	SHLR	6917.5	-243
239	SHLR	7002.5	-243
240	UPDN	7087.5	-243
241	UPDN	7172.5	-243
242	DUM_GND	7257.5	-243
243	TEST16	7342.5	-243
244	TEST17	7427.5	-243
245	TEST18	7512.5	-243
246	TEST19	7597.5	-243
247	TEST20	7682.5	-243
248	TEST21	7767.5	-243
249	TEST22	7852.5	-243
250	TEST23	7937.5	-243
251	TEST24	8022.5	-243
252	TEST25	8107.5	-243
253	TEST26	8192.5	-243
254	TEST27	8277.5	-243
255	TEST28	8362.5	-243
256	TEST29	8447.5	-243
257	DUM_GND	8532.5	-243
258	VDD	8617.5	-243
259	VDD	8702.5	-243
260	VDD	8787.5	-243
261	VDD	8872.5	-243
262	DUM_GND	8957.5	-243
263	VSS	9042.5	-243
264	VSS	9127.5	-243
265	VSS	9212.5	-243
266	VSS	9297.5	-243
267	DUM_GND	9382.5	-243
268	VDDA	9467.5	-243
269	VDDA	9552.5	-243
270	VDDA	9637.5	-243
271	VDDA	9722.5	-243
272	DUM_GND	9807.5	-243
273	VSSA	9892.5	-243
274	VSSA	9977.5	-243
275	VSSA	10062.5	-243
276	VSSA	10147.5	-243
277	DUM_GND	10232.5	-243
278	DUM_GND	10317.5	-243
279	VCOMI	10402.5	-243

NO.	PAD NAME	X	Y
280	VCOMI	10487.5	-243
281	PWR_EN	10572.5	-243
282	PWR_EN	10657.5	-243
283	FBL	10742.5	-243
284	FBL	10827.5	-243
285	FBH	10912.5	-243
286	FBH	10997.5	-243
287	FBA	11082.5	-243
288	FBA	11167.5	-243
289	DUM	11252.5	-243
290	DUM	11337.5	-243
291	DRVA	11422.5	-243
292	DRVA	11507.5	-243
293	DRVH	11592.5	-243
294	DRVH	11677.5	-243
295	DRVL	11762.5	-243
296	DRVL	11847.5	-243
297	DRVL_B	11932.5	-243
298	DRVL_B	12017.5	-243
299	VCOMO	12102.5	-243
300	VCOMO	12187.5	-243
301	COM_PASSA	12272.5	-243
302	COM_PASSA	12357.5	-243
303	STBN_L	12303	-82
304	F_Ctrl_L	12396.5	-42
305	STV2_L	12303	-2
306	STV1_L	12396.5	38
307	CKV_L	12303	78
308	UD_L	12396.5	118
309	SYNC2_L	12303	158
310	SYNC1_L	12396.5	198
311	F_Ctrl_L	12396.5	278
312	OEVL	12303	238
313	DUM_GND	12205	258
314	COM_PASSA	12155	258
315	COM_PASSA	12105	258
316	DUM_GND	12055	258
317	S1	12012.5	113
318	S2	11997.5	243
319	S3	11982.5	113
320	S4	11967.5	243
321	S5	11952.5	113
322	S6	11937.5	243
323	S7	11922.5	113
324	S8	11907.5	243
325	S9	11892.5	113
326	S10	11877.5	243
327	S11	11862.5	113
328	S12	11847.5	243
329	S13	11832.5	113
330	S14	11817.5	243
331	S15	11802.5	113
332	S16	11787.5	243
333	S17	11772.5	113
334	S18	11757.5	243
335	S19	11742.5	113
336	S20	11727.5	243

NO.	PAD NAME	X	Y
337	S21	11712.5	113
338	S22	11697.5	243
339	S23	11682.5	113
340	S24	11667.5	243
341	S25	11652.5	113
342	S26	11637.5	243
343	S27	11622.5	113
344	S28	11607.5	243
345	S29	11592.5	113
346	S30	11577.5	243
347	S31	11562.5	113
348	S32	11547.5	243
349	S33	11532.5	113
350	S34	11517.5	243
351	S35	11502.5	113
352	S36	11487.5	243
353	S37	11472.5	113
354	S38	11457.5	243
355	S39	11442.5	113
356	S40	11427.5	243
357	S41	11412.5	113
358	S42	11397.5	243
359	S43	11382.5	113
360	S44	11367.5	243
361	S45	11352.5	113
362	S46	11337.5	243
363	S47	11322.5	113
364	S48	11307.5	243
365	S49	11292.5	113
366	S50	11277.5	243
367	S51	11262.5	113
368	S52	11247.5	243
369	S53	11232.5	113
370	S54	11217.5	243
371	S55	11202.5	113
372	S56	11187.5	243
373	S57	11172.5	113
374	S58	11157.5	243
375	S59	11142.5	113
376	S60	11127.5	243
377	S61	11112.5	113
378	S62	11097.5	243
379	S63	11082.5	113
380	S64	11067.5	243
381	S65	11052.5	113
382	S66	11037.5	243
383	S67	11022.5	113
384	S68	11007.5	243
385	S69	10992.5	113
386	S70	10977.5	243
387	S71	10962.5	113
388	S72	10947.5	243
389	S73	10932.5	113
390	S74	10917.5	243
391	S75	10902.5	113
392	S76	10887.5	243
393	S77	10872.5	113

NO.	PAD NAME	X	Y
394	S78	10857.5	243
395	S79	10842.5	113
396	S80	10827.5	243
397	S81	10812.5	113
398	S82	10797.5	243
399	S83	10782.5	113
400	S84	10767.5	243
401	S85	10752.5	113
402	S86	10737.5	243
403	S87	10722.5	113
404	S88	10707.5	243
405	S89	10692.5	113
406	S90	10677.5	243
407	S91	10662.5	113
408	S92	10647.5	243
409	S93	10632.5	113
410	S94	10617.5	243
411	S95	10602.5	113
412	S96	10587.5	243
413	S97	10572.5	113
414	S98	10557.5	243
415	S99	10542.5	113
416	S100	10527.5	243
417	S101	10512.5	113
418	S102	10497.5	243
419	S103	10482.5	113
420	S104	10467.5	243
421	S105	10452.5	113
422	S106	10437.5	243
423	S107	10422.5	113
424	S108	10407.5	243
425	S109	10392.5	113
426	S110	10377.5	243
427	S111	10362.5	113
428	S112	10347.5	243
429	S113	10332.5	113
430	S114	10317.5	243
431	S115	10302.5	113
432	S116	10287.5	243
433	S117	10272.5	113
434	S118	10257.5	243
435	S119	10242.5	113
436	S120	10227.5	243
437	S121	10212.5	113
438	S122	10197.5	243
439	S123	10182.5	113
440	S124	10167.5	243
441	S125	10152.5	113
442	S126	10137.5	243
443	S127	10122.5	113
444	S128	10107.5	243
445	S129	10092.5	113
446	S130	10077.5	243
447	S131	10062.5	113
448	S132	10047.5	243
449	S133	10032.5	113
450	S134	10017.5	243

NO.	PAD NAME	X	Y
451	S135	10002.5	113
452	S136	9987.5	243
453	S137	9972.5	113
454	S138	9957.5	243
455	S139	9942.5	113
456	S140	9927.5	243
457	S141	9912.5	113
458	S142	9897.5	243
459	S143	9882.5	113
460	S144	9867.5	243
461	S145	9852.5	113
462	S146	9837.5	243
463	S147	9822.5	113
464	S148	9807.5	243
465	S149	9792.5	113
466	S150	9777.5	243
467	S151	9762.5	113
468	S152	9747.5	243
469	S153	9732.5	113
470	S154	9717.5	243
471	S155	9702.5	113
472	S156	9687.5	243
473	S157	9672.5	113
474	S158	9657.5	243
475	S159	9642.5	113
476	S160	9627.5	243
477	S161	9612.5	113
478	S162	9597.5	243
479	S163	9582.5	113
480	S164	9567.5	243
481	S165	9552.5	113
482	S166	9537.5	243
483	S167	9522.5	113
484	S168	9507.5	243
485	S169	9492.5	113
486	S170	9477.5	243
487	S171	9462.5	113
488	S172	9447.5	243
489	S173	9432.5	113
490	S174	9417.5	243
491	S175	9402.5	113
492	S176	9387.5	243
493	S177	9372.5	113
494	S178	9357.5	243
495	S179	9342.5	113
496	S180	9327.5	243
497	S181	9312.5	113
498	S182	9297.5	243
499	S183	9282.5	113
500	S184	9267.5	243
501	S185	9252.5	113
502	S186	9237.5	243
503	S187	9222.5	113
504	S188	9207.5	243
505	S189	9192.5	113
506	S190	9177.5	243
507	S191	9162.5	113

NO.	PAD NAME	X	Y
508	S192	9147.5	243
509	S193	9132.5	113
510	S194	9117.5	243
511	S195	9102.5	113
512	S196	9087.5	243
513	S197	9072.5	113
514	S198	9057.5	243
515	S199	9042.5	113
516	S200	9027.5	243
517	S201	9012.5	113
518	S202	8997.5	243
519	S203	8982.5	113
520	S204	8967.5	243
521	S205	8952.5	113
522	S206	8937.5	243
523	S207	8922.5	113
524	S208	8907.5	243
525	S209	8892.5	113
526	S210	8877.5	243
527	S211	8862.5	113
528	S212	8847.5	243
529	S213	8832.5	113
530	S214	8817.5	243
531	S215	8802.5	113
532	S216	8787.5	243
533	S217	8772.5	113
534	S218	8757.5	243
535	S219	8742.5	113
536	S220	8727.5	243
537	S221	8712.5	113
538	S222	8697.5	243
539	S223	8682.5	113
540	S224	8667.5	243
541	S225	8652.5	113
542	S226	8637.5	243
543	S227	8622.5	113
544	S228	8607.5	243
545	S229	8592.5	113
546	S230	8577.5	243
547	S231	8562.5	113
548	S232	8547.5	243
549	S233	8532.5	113
550	S234	8517.5	243
551	S235	8502.5	113
552	S236	8487.5	243
553	S237	8472.5	113
554	S238	8457.5	243
555	S239	8442.5	113
556	S240	8427.5	243
557	S241	8412.5	113
558	S242	8397.5	243
559	S243	8382.5	113
560	S244	8367.5	243
561	S245	8352.5	113
562	S246	8337.5	243
563	S247	8322.5	113
564	S248	8307.5	243

NO.	PAD NAME	X	Y
565	S249	8292.5	113
566	S250	8277.5	243
567	S251	8262.5	113
568	S252	8247.5	243
569	S253	8232.5	113
570	S254	8217.5	243
571	S255	8202.5	113
572	S256	8187.5	243
573	S257	8172.5	113
574	S258	8157.5	243
575	S259	8142.5	113
576	S260	8127.5	243
577	S261	8112.5	113
578	S262	8097.5	243
579	S263	8082.5	113
580	S264	8067.5	243
581	S265	8052.5	113
582	S266	8037.5	243
583	S267	8022.5	113
584	S268	8007.5	243
585	S269	7992.5	113
586	S270	7977.5	243
587	S271	7962.5	113
588	S272	7947.5	243
589	S273	7932.5	113
590	S274	7917.5	243
591	S275	7902.5	113
592	S276	7887.5	243
593	S277	7872.5	113
594	S278	7857.5	243
595	S279	7842.5	113
596	S280	7827.5	243
597	S281	7812.5	113
598	S282	7797.5	243
599	S283	7782.5	113
600	S284	7767.5	243
601	S285	7752.5	113
602	S286	7737.5	243
603	S287	7722.5	113
604	S288	7707.5	243
605	S289	7692.5	113
606	S290	7677.5	243
607	S291	7662.5	113
608	S292	7647.5	243
609	S293	7632.5	113
610	S294	7617.5	243
611	S295	7602.5	113
612	S296	7587.5	243
613	S297	7572.5	113
614	S298	7557.5	243
615	S299	7542.5	113
616	S300	7527.5	243
617	S301	7512.5	113
618	S302	7497.5	243
619	S303	7482.5	113
620	S304	7467.5	243
621	S305	7452.5	113

NO.	PAD NAME	X	Y
622	S306	7437.5	243
623	S307	7422.5	113
624	S308	7407.5	243
625	S309	7392.5	113
626	S310	7377.5	243
627	S311	7362.5	113
628	S312	7347.5	243
629	S313	7332.5	113
630	S314	7317.5	243
631	S315	7302.5	113
632	S316	7287.5	243
633	S317	7272.5	113
634	S318	7257.5	243
635	S319	7242.5	113
636	S320	7227.5	243
637	S321	7212.5	113
638	S322	7197.5	243
639	S323	7182.5	113
640	S324	7167.5	243
641	S325	7152.5	113
642	S326	7137.5	243
643	S327	7122.5	113
644	S328	7107.5	243
645	S329	7092.5	113
646	S330	7077.5	243
647	S331	7062.5	113
648	S332	7047.5	243
649	S333	7032.5	113
650	S334	7017.5	243
651	S335	7002.5	113
652	S336	6987.5	243
653	S337	6972.5	113
654	S338	6957.5	243
655	S339	6942.5	113
656	S340	6927.5	243
657	S341	6912.5	113
658	S342	6897.5	243
659	S343	6882.5	113
660	S344	6867.5	243
661	S345	6852.5	113
662	S346	6837.5	243
663	S347	6822.5	113
664	S348	6807.5	243
665	S349	6792.5	113
666	S350	6777.5	243
667	S351	6762.5	113
668	S352	6747.5	243
669	S353	6732.5	113
670	S354	6717.5	243
671	S355	6702.5	113
672	S356	6687.5	243
673	S357	6672.5	113
674	S358	6657.5	243
675	S359	6642.5	113
676	S360	6627.5	243
677	S361	6612.5	113
678	S362	6597.5	243

NO.	PAD NAME	X	Y
679	S363	6582.5	113
680	S364	6567.5	243
681	S365	6552.5	113
682	S366	6537.5	243
683	S367	6522.5	113
684	S368	6507.5	243
685	S369	6492.5	113
686	S370	6477.5	243
687	S371	6462.5	113
688	S372	6447.5	243
689	S373	6432.5	113
690	S374	6417.5	243
691	S375	6402.5	113
692	S376	6387.5	243
693	S377	6372.5	113
694	S378	6357.5	243
695	S379	6342.5	113
696	S380	6327.5	243
697	S381	6312.5	113
698	S382	6297.5	243
699	S383	6282.5	113
700	S384	6267.5	243
701	S385	6252.5	113
702	S386	6237.5	243
703	S387	6222.5	113
704	S388	6207.5	243
705	S389	6192.5	113
706	S390	6177.5	243
707	S391	6162.5	113
708	S392	6147.5	243
709	S393	6132.5	113
710	S394	6117.5	243
711	S395	6102.5	113
712	S396	6087.5	243
713	S397	6072.5	113
714	S398	6057.5	243
715	S399	6042.5	113
716	S400	6027.5	243
717	S401	6012.5	113
718	S402	5997.5	243
719	S403	5982.5	113
720	S404	5967.5	243
721	S405	5952.5	113
722	S406	5937.5	243
723	S407	5922.5	113
724	S408	5907.5	243
725	S409	5892.5	113
726	S410	5877.5	243
727	S411	5862.5	113
728	S412	5847.5	243
729	S413	5832.5	113
730	S414	5817.5	243
731	S415	5802.5	113
732	S416	5787.5	243
733	S417	5772.5	113
734	S418	5757.5	243
735	S419	5742.5	113

NO.	PAD NAME	X	Y
736	S420	5727.5	243
737	S421	5712.5	113
738	S422	5697.5	243
739	S423	5682.5	113
740	S424	5667.5	243
741	S425	5652.5	113
742	S426	5637.5	243
743	S427	5622.5	113
744	S428	5607.5	243
745	S429	5592.5	113
746	S430	5577.5	243
747	S431	5562.5	113
748	S432	5547.5	243
749	S433	5532.5	113
750	S434	5517.5	243
751	S435	5502.5	113
752	S436	5487.5	243
753	S437	5472.5	113
754	S438	5457.5	243
755	S439	5442.5	113
756	S440	5427.5	243
757	S441	5412.5	113
758	S442	5397.5	243
759	S443	5382.5	113
760	S444	5367.5	243
761	S445	5352.5	113
762	S446	5337.5	243
763	S447	5322.5	113
764	S448	5307.5	243
765	S449	5292.5	113
766	S450	5277.5	243
767	S451	5262.5	113
768	S452	5247.5	243
769	S453	5232.5	113
770	S454	5217.5	243
771	S455	5202.5	113
772	S456	5187.5	243
773	S457	5172.5	113
774	S458	5157.5	243
775	S459	5142.5	113
776	S460	5127.5	243
777	S461	5112.5	113
778	S462	5097.5	243
779	S463	5082.5	113
780	S464	5067.5	243
781	S465	5052.5	113
782	S466	5037.5	243
783	S467	5022.5	113
784	S468	5007.5	243
785	S469	4992.5	113
786	S470	4977.5	243
787	S471	4962.5	113
788	S472	4947.5	243
789	S473	4932.5	113
790	S474	4917.5	243
791	S475	4902.5	113
792	S476	4887.5	243

NO.	PAD NAME	X	Y
793	S477	4872.5	113
794	S478	4857.5	243
795	S479	4842.5	113
796	S480	4827.5	243
797	S481	4812.5	113
798	S482	4797.5	243
799	S483	4782.5	113
800	S484	4767.5	243
801	S485	4752.5	113
802	S486	4737.5	243
803	S487	4722.5	113
804	S488	4707.5	243
805	S489	4692.5	113
806	S490	4677.5	243
807	S491	4662.5	113
808	S492	4647.5	243
809	S493	4632.5	113
810	S494	4617.5	243
811	S495	4602.5	113
812	S496	4587.5	243
813	S497	4572.5	113
814	S498	4557.5	243
815	S499	4542.5	113
816	S500	4527.5	243
817	S501	4512.5	113
818	S502	4497.5	243
819	S503	4482.5	113
820	S504	4467.5	243
821	S505	4452.5	113
822	S506	4437.5	243
823	S507	4422.5	113
824	S508	4407.5	243
825	S509	4392.5	113
826	S510	4377.5	243
827	S511	4362.5	113
828	S512	4347.5	243
829	S513	4332.5	113
830	S514	4317.5	243
831	S515	4302.5	113
832	S516	4287.5	243
833	S517	4272.5	113
834	S518	4257.5	243
835	S519	4242.5	113
836	S520	4227.5	243
837	S521	4212.5	113
838	S522	4197.5	243
839	S523	4182.5	113
840	S524	4167.5	243
841	S525	4152.5	113
842	S526	4137.5	243
843	S527	4122.5	113
844	S528	4107.5	243
845	S529	4092.5	113
846	S530	4077.5	243
847	S531	4062.5	113
848	S532	4047.5	243
849	S533	4032.5	113

NO.	PAD NAME	X	Y
850	S534	4017.5	243
851	S535	4002.5	113
852	S536	3987.5	243
853	S537	3972.5	113
854	S538	3957.5	243
855	S539	3942.5	113
856	S540	3927.5	243
857	S541	3912.5	113
858	S542	3897.5	243
859	S543	3882.5	113
860	S544	3867.5	243
861	S545	3852.5	113
862	S546	3837.5	243
863	S547	3822.5	113
864	S548	3807.5	243
865	S549	3792.5	113
866	S550	3777.5	243
867	S551	3762.5	113
868	S552	3747.5	243
869	S553	3732.5	113
870	S554	3717.5	243
871	S555	3702.5	113
872	S556	3687.5	243
873	S557	3672.5	113
874	S558	3657.5	243
875	S559	3642.5	113
876	S560	3627.5	243
877	S561	3612.5	113
878	S562	3597.5	243
879	S563	3582.5	113
880	S564	3567.5	243
881	S565	3552.5	113
882	S566	3537.5	243
883	S567	3522.5	113
884	S568	3507.5	243
885	S569	3492.5	113
886	S570	3477.5	243
887	S571	3462.5	113
888	S572	3447.5	243
889	S573	3432.5	113
890	S574	3417.5	243
891	S575	3402.5	113
892	S576	3387.5	243
893	S577	3372.5	113
894	S578	3357.5	243
895	S579	3342.5	113
896	S580	3327.5	243
897	S581	3312.5	113
898	S582	3297.5	243
899	S583	3282.5	113
900	S584	3267.5	243
901	S585	3252.5	113
902	S586	3237.5	243
903	S587	3222.5	113
904	S588	3207.5	243
905	S589	3192.5	113
906	S590	3177.5	243

NO.	PAD NAME	X	Y
907	S591	3162.5	113
908	S592	3147.5	243
909	S593	3132.5	113
910	S594	3117.5	243
911	S595	3102.5	113
912	S596	3087.5	243
913	S597	3072.5	113
914	S598	3057.5	243
915	S599	3042.5	113
916	S600	3027.5	243
917	S601	3012.5	113
918	S602	2997.5	243
919	S603	2982.5	113
920	S604	2967.5	243
921	S605	2952.5	113
922	S606	2937.5	243
923	S607	2922.5	113
924	S608	2907.5	243
925	S609	2892.5	113
926	S610	2877.5	243
927	S611	2862.5	113
928	S612	2847.5	243
929	S613	2832.5	113
930	S614	2817.5	243
931	S615	2802.5	113
932	S616	2787.5	243
933	S617	2772.5	113
934	S618	2757.5	243
935	S619	2742.5	113
936	S620	2727.5	243
937	S621	2712.5	113
938	S622	2697.5	243
939	S623	2682.5	113
940	S624	2667.5	243
941	S625	2652.5	113
942	S626	2637.5	243
943	S627	2622.5	113
944	S628	2607.5	243
945	S629	2592.5	113
946	S630	2577.5	243
947	S631	2562.5	113
948	S632	2547.5	243
949	S633	2532.5	113
950	S634	2517.5	243
951	S635	2502.5	113
952	S636	2487.5	243
953	S637	2472.5	113
954	S638	2457.5	243
955	S639	2442.5	113
956	S640	2427.5	243
957	S641	2412.5	113
958	S642	2397.5	243
959	S643	2382.5	113
960	S644	2367.5	243
961	S645	2352.5	113
962	S646	2337.5	243
963	S647	2322.5	113

NO.	PAD NAME	X	Y
964	S648	2307.5	243
965	S649	2292.5	113
966	S650	2277.5	243
967	S651	2262.5	113
968	S652	2247.5	243
969	S653	2232.5	113
970	S654	2217.5	243
971	S655	2202.5	113
972	S656	2187.5	243
973	S657	2172.5	113
974	S658	2157.5	243
975	S659	2142.5	113
976	S660	2127.5	243
977	S661	2112.5	113
978	S662	2097.5	243
979	S663	2082.5	113
980	S664	2067.5	243
981	S665	2052.5	113
982	S666	2037.5	243
983	S667	2022.5	113
984	S668	2007.5	243
985	S669	1992.5	113
986	S670	1977.5	243
987	S671	1962.5	113
988	S672	1947.5	243
989	S673	1932.5	113
990	S674	1917.5	243
991	S675	1902.5	113
992	S676	1887.5	243
993	S677	1872.5	113
994	S678	1857.5	243
995	S679	1842.5	113
996	S680	1827.5	243
997	S681	1812.5	113
998	S682	1797.5	243
999	S683	1782.5	113
1000	S684	1767.5	243
1001	S685	1752.5	113
1002	S686	1737.5	243
1003	S687	1722.5	113
1004	S688	1707.5	243
1005	S689	1692.5	113
1006	S690	1677.5	243
1007	S691	1662.5	113
1008	S692	1647.5	243
1009	S693	1632.5	113
1010	S694	1617.5	243
1011	S695	1602.5	113
1012	S696	1587.5	243
1013	S697	1572.5	113
1014	S698	1557.5	243
1015	S699	1542.5	113
1016	S700	1527.5	243
1017	S701	1512.5	113
1018	S702	1497.5	243
1019	S703	1482.5	113
1020	S704	1467.5	243

NO.	PAD NAME	X	Y
1021	S705	1452.5	113
1022	S706	1437.5	243
1023	S707	1422.5	113
1024	S708	1407.5	243
1025	S709	1392.5	113
1026	S710	1377.5	243
1027	S711	1362.5	113
1028	S712	1347.5	243
1029	S713	1332.5	113
1030	S714	1317.5	243
1031	S715	1302.5	113
1032	S716	1287.5	243
1033	S717	1272.5	113
1034	S718	1257.5	243
1035	S719	1242.5	113
1036	S720	1227.5	243
1037	S721	1212.5	113
1038	S722	1197.5	243
1039	S723	1182.5	113
1040	S724	1167.5	243
1041	S725	1152.5	113
1042	S726	1137.5	243
1043	S727	1122.5	113
1044	S728	1107.5	243
1045	S729	1092.5	113
1046	S730	1077.5	243
1047	S731	1062.5	113
1048	S732	1047.5	243
1049	S733	1032.5	113
1050	S734	1017.5	243
1051	S735	1002.5	113
1052	S736	987.5	243
1053	S737	972.5	113
1054	S738	957.5	243
1055	S739	942.5	113
1056	S740	927.5	243
1057	S741	912.5	113
1058	S742	897.5	243
1059	S743	882.5	113
1060	S744	867.5	243
1061	S745	852.5	113
1062	S746	837.5	243
1063	S747	822.5	113
1064	S748	807.5	243
1065	S749	792.5	113
1066	S750	777.5	243
1067	S751	762.5	113
1068	S752	747.5	243
1069	S753	732.5	113
1070	S754	717.5	243
1071	S755	702.5	113
1072	S756	687.5	243
1073	S757	672.5	113
1074	S758	657.5	243
1075	S759	642.5	113
1076	S760	627.5	243
1077	S761	612.5	113

NO.	PAD NAME	X	Y
1078	S762	597.5	243
1079	S763	582.5	113
1080	S764	567.5	243
1081	S765	552.5	113
1082	S766	537.5	243
1083	S767	522.5	113
1084	S768	507.5	243
1085	DUM_GND	455	258
1086	DUM_GND	405	258
1087	DUM_GND	355	258
1088	DUM_GND	300	258
1089	DUM_GND	250	258
1090	DUM_GND	200	258
1091	DUM_GND	150	258
1092	DUM_GND	100	258
1093	DUM_GND	50	258
1094	DUM_GND	0	258
1095	DUM_GND	-50	258
1096	DUM_GND	-100	258
1097	DUM_GND	-150	258
1098	DUM_GND	-200	258
1099	DUM_GND	-250	258
1100	DUM_GND	-300	258
1101	DUM_GND	-355	258
1102	DUM_GND	-405	258
1103	DUM_GND	-455	258
1104	V_5V	492.5	113
1105	V_5V	462.5	113
1106	V_5V	432.5	113
1107	V_5V	402.5	113
1108	VSSD	372.5	113
1109	VSSD	342.5	113
1110	VSSD	-342.5	113
1111	VSSD	-372.5	113
1112	V_5V	-402.5	113
1113	V_5V	-432.5	113
1114	V_5V	-462.5	113
1115	V_5V	-492.5	113
1116	S769	-507.5	243
1117	S770	-522.5	113
1118	S771	-537.5	243
1119	S772	-552.5	113
1120	S773	-567.5	243
1121	S774	-582.5	113
1122	S775	-597.5	243
1123	S776	-612.5	113
1124	S777	-627.5	243
1125	S778	-642.5	113
1126	S779	-657.5	243
1127	S780	-672.5	113
1128	S781	-687.5	243
1129	S782	-702.5	113
1130	S783	-717.5	243
1131	S784	-732.5	113
1132	S785	-747.5	243
1133	S786	-762.5	113
1134	S787	-777.5	243

NO.	PAD NAME	X	Y
1135	S788	-792.5	113
1136	S789	-807.5	243
1137	S790	-822.5	113
1138	S791	-837.5	243
1139	S792	-852.5	113
1140	S793	-867.5	243
1141	S794	-882.5	113
1142	S795	-897.5	243
1143	S796	-912.5	113
1144	S797	-927.5	243
1145	S798	-942.5	113
1146	S799	-957.5	243
1147	S800	-972.5	113
1148	S801	-987.5	243
1149	S802	-1002.5	113
1150	S803	-1017.5	243
1151	S804	-1032.5	113
1152	S805	-1047.5	243
1153	S806	-1062.5	113
1154	S807	-1077.5	243
1155	S808	-1092.5	113
1156	S809	-1107.5	243
1157	S810	-1122.5	113
1158	S811	-1137.5	243
1159	S812	-1152.5	113
1160	S813	-1167.5	243
1161	S814	-1182.5	113
1162	S815	-1197.5	243
1163	S816	-1212.5	113
1164	S817	-1227.5	243
1165	S818	-1242.5	113
1166	S819	-1257.5	243
1167	S820	-1272.5	113
1168	S821	-1287.5	243
1169	S822	-1302.5	113
1170	S823	-1317.5	243
1171	S824	-1332.5	113
1172	S825	-1347.5	243
1173	S826	-1362.5	113
1174	S827	-1377.5	243
1175	S828	-1392.5	113
1176	S829	-1407.5	243
1177	S830	-1422.5	113
1178	S831	-1437.5	243
1179	S832	-1452.5	113
1180	S833	-1467.5	243
1181	S834	-1482.5	113
1182	S835	-1497.5	243
1183	S836	-1512.5	113
1184	S837	-1527.5	243
1185	S838	-1542.5	113
1186	S839	-1557.5	243
1187	S840	-1572.5	113
1188	S841	-1587.5	243
1189	S842	-1602.5	113
1190	S843	-1617.5	243
1191	S844	-1632.5	113

NO.	PAD NAME	X	Y
1192	S845	-1647.5	243
1193	S846	-1662.5	113
1194	S847	-1677.5	243
1195	S848	-1692.5	113
1196	S849	-1707.5	243
1197	S850	-1722.5	113
1198	S851	-1737.5	243
1199	S852	-1752.5	113
1200	S853	-1767.5	243
1201	S854	-1782.5	113
1202	S855	-1797.5	243
1203	S856	-1812.5	113
1204	S857	-1827.5	243
1205	S858	-1842.5	113
1206	S859	-1857.5	243
1207	S860	-1872.5	113
1208	S861	-1887.5	243
1209	S862	-1902.5	113
1210	S863	-1917.5	243
1211	S864	-1932.5	113
1212	S865	-1947.5	243
1213	S866	-1962.5	113
1214	S867	-1977.5	243
1215	S868	-1992.5	113
1216	S869	-2007.5	243
1217	S870	-2022.5	113
1218	S871	-2037.5	243
1219	S872	-2052.5	113
1220	S873	-2067.5	243
1221	S874	-2082.5	113
1222	S875	-2097.5	243
1223	S876	-2112.5	113
1224	S877	-2127.5	243
1225	S878	-2142.5	113
1226	S879	-2157.5	243
1227	S880	-2172.5	113
1228	S881	-2187.5	243
1229	S882	-2202.5	113
1230	S883	-2217.5	243
1231	S884	-2232.5	113
1232	S885	-2247.5	243
1233	S886	-2262.5	113
1234	S887	-2277.5	243
1235	S888	-2292.5	113
1236	S889	-2307.5	243
1237	S890	-2322.5	113
1238	S891	-2337.5	243
1239	S892	-2352.5	113
1240	S893	-2367.5	243
1241	S894	-2382.5	113
1242	S895	-2397.5	243
1243	S896	-2412.5	113
1244	S897	-2427.5	243
1245	S898	-2442.5	113
1246	S899	-2457.5	243
1247	S900	-2472.5	113
1248	S901	-2487.5	243

NO.	PAD NAME	X	Y
1249	S902	-2502.5	113
1250	S903	-2517.5	243
1251	S904	-2532.5	113
1252	S905	-2547.5	243
1253	S906	-2562.5	113
1254	S907	-2577.5	243
1255	S908	-2592.5	113
1256	S909	-2607.5	243
1257	S910	-2622.5	113
1258	S911	-2637.5	243
1259	S912	-2652.5	113
1260	S913	-2667.5	243
1261	S914	-2682.5	113
1262	S915	-2697.5	243
1263	S916	-2712.5	113
1264	S917	-2727.5	243
1265	S918	-2742.5	113
1266	S919	-2757.5	243
1267	S920	-2772.5	113
1268	S921	-2787.5	243
1269	S922	-2802.5	113
1270	S923	-2817.5	243
1271	S924	-2832.5	113
1272	S925	-2847.5	243
1273	S926	-2862.5	113
1274	S927	-2877.5	243
1275	S928	-2892.5	113
1276	S929	-2907.5	243
1277	S930	-2922.5	113
1278	S931	-2937.5	243
1279	S932	-2952.5	113
1280	S933	-2967.5	243
1281	S934	-2982.5	113
1282	S935	-2997.5	243
1283	S936	-3012.5	113
1284	S937	-3027.5	243
1285	S938	-3042.5	113
1286	S939	-3057.5	243
1287	S940	-3072.5	113
1288	S941	-3087.5	243
1289	S942	-3102.5	113
1290	S943	-3117.5	243
1291	S944	-3132.5	113
1292	S945	-3147.5	243
1293	S946	-3162.5	113
1294	S947	-3177.5	243
1295	S948	-3192.5	113
1296	S949	-3207.5	243
1297	S950	-3222.5	113
1298	S951	-3237.5	243
1299	S952	-3252.5	113
1300	S953	-3267.5	243
1301	S954	-3282.5	113
1302	S955	-3297.5	243
1303	S956	-3312.5	113
1304	S957	-3327.5	243
1305	S958	-3342.5	113

NO.	PAD NAME	X	Y
1306	S959	-3357.5	243
1307	S960	-3372.5	113
1308	S961	-3387.5	243
1309	S962	-3402.5	113
1310	S963	-3417.5	243
1311	S964	-3432.5	113
1312	S965	-3447.5	243
1313	S966	-3462.5	113
1314	S967	-3477.5	243
1315	S968	-3492.5	113
1316	S969	-3507.5	243
1317	S970	-3522.5	113
1318	S971	-3537.5	243
1319	S972	-3552.5	113
1320	S973	-3567.5	243
1321	S974	-3582.5	113
1322	S975	-3597.5	243
1323	S976	-3612.5	113
1324	S977	-3627.5	243
1325	S978	-3642.5	113
1326	S979	-3657.5	243
1327	S980	-3672.5	113
1328	S981	-3687.5	243
1329	S982	-3702.5	113
1330	S983	-3717.5	243
1331	S984	-3732.5	113
1332	S985	-3747.5	243
1333	S986	-3762.5	113
1334	S987	-3777.5	243
1335	S988	-3792.5	113
1336	S989	-3807.5	243
1337	S990	-3822.5	113
1338	S991	-3837.5	243
1339	S992	-3852.5	113
1340	S993	-3867.5	243
1341	S994	-3882.5	113
1342	S995	-3897.5	243
1343	S996	-3912.5	113
1344	S997	-3927.5	243
1345	S998	-3942.5	113
1346	S999	-3957.5	243
1347	S1000	-3972.5	113
1348	S1001	-3987.5	243
1349	S1002	-4002.5	113
1350	S1003	-4017.5	243
1351	S1004	-4032.5	113
1352	S1005	-4047.5	243
1353	S1006	-4062.5	113
1354	S1007	-4077.5	243
1355	S1008	-4092.5	113
1356	S1009	-4107.5	243
1357	S1010	-4122.5	113
1358	S1011	-4137.5	243
1359	S1012	-4152.5	113
1360	S1013	-4167.5	243
1361	S1014	-4182.5	113
1362	S1015	-4197.5	243

NO.	PAD NAME	X	Y
1363	S1016	-4212.5	113
1364	S1017	-4227.5	243
1365	S1018	-4242.5	113
1366	S1019	-4257.5	243
1367	S1020	-4272.5	113
1368	S1021	-4287.5	243
1369	S1022	-4302.5	113
1370	S1023	-4317.5	243
1371	S1024	-4332.5	113
1372	S1025	-4347.5	243
1373	S1026	-4362.5	113
1374	S1027	-4377.5	243
1375	S1028	-4392.5	113
1376	S1029	-4407.5	243
1377	S1030	-4422.5	113
1378	S1031	-4437.5	243
1379	S1032	-4452.5	113
1380	S1033	-4467.5	243
1381	S1034	-4482.5	113
1382	S1035	-4497.5	243
1383	S1036	-4512.5	113
1384	S1037	-4527.5	243
1385	S1038	-4542.5	113
1386	S1039	-4557.5	243
1387	S1040	-4572.5	113
1388	S1041	-4587.5	243
1389	S1042	-4602.5	113
1390	S1043	-4617.5	243
1391	S1044	-4632.5	113
1392	S1045	-4647.5	243
1393	S1046	-4662.5	113
1394	S1047	-4677.5	243
1395	S1048	-4692.5	113
1396	S1049	-4707.5	243
1397	S1050	-4722.5	113
1398	S1051	-4737.5	243
1399	S1052	-4752.5	113
1400	S1053	-4767.5	243
1401	S1054	-4782.5	113
1402	S1055	-4797.5	243
1403	S1056	-4812.5	113
1404	S1057	-4827.5	243
1405	S1058	-4842.5	113
1406	S1059	-4857.5	243
1407	S1060	-4872.5	113
1408	S1061	-4887.5	243
1409	S1062	-4902.5	113
1410	S1063	-4917.5	243
1411	S1064	-4932.5	113
1412	S1065	-4947.5	243
1413	S1066	-4962.5	113
1414	S1067	-4977.5	243
1415	S1068	-4992.5	113
1416	S1069	-5007.5	243
1417	S1070	-5022.5	113
1418	S1071	-5037.5	243
1419	S1072	-5052.5	113

NO.	PAD NAME	X	Y
1420	S1073	-5067.5	243
1421	S1074	-5082.5	113
1422	S1075	-5097.5	243
1423	S1076	-5112.5	113
1424	S1077	-5127.5	243
1425	S1078	-5142.5	113
1426	S1079	-5157.5	243
1427	S1080	-5172.5	113
1428	S1081	-5187.5	243
1429	S1082	-5202.5	113
1430	S1083	-5217.5	243
1431	S1084	-5232.5	113
1432	S1085	-5247.5	243
1433	S1086	-5262.5	113
1434	S1087	-5277.5	243
1435	S1088	-5292.5	113
1436	S1089	-5307.5	243
1437	S1090	-5322.5	113
1438	S1091	-5337.5	243
1439	S1092	-5352.5	113
1440	S1093	-5367.5	243
1441	S1094	-5382.5	113
1442	S1095	-5397.5	243
1443	S1096	-5412.5	113
1444	S1097	-5427.5	243
1445	S1098	-5442.5	113
1446	S1099	-5457.5	243
1447	S1100	-5472.5	113
1448	S1101	-5487.5	243
1449	S1102	-5502.5	113
1450	S1103	-5517.5	243
1451	S1104	-5532.5	113
1452	S1105	-5547.5	243
1453	S1106	-5562.5	113
1454	S1107	-5577.5	243
1455	S1108	-5592.5	113
1456	S1109	-5607.5	243
1457	S1110	-5622.5	113
1458	S1111	-5637.5	243
1459	S1112	-5652.5	113
1460	S1113	-5667.5	243
1461	S1114	-5682.5	113
1462	S1115	-5697.5	243
1463	S1116	-5712.5	113
1464	S1117	-5727.5	243
1465	S1118	-5742.5	113
1466	S1119	-5757.5	243
1467	S1120	-5772.5	113
1468	S1121	-5787.5	243
1469	S1122	-5802.5	113
1470	S1123	-5817.5	243
1471	S1124	-5832.5	113
1472	S1125	-5847.5	243
1473	S1126	-5862.5	113
1474	S1127	-5877.5	243
1475	S1128	-5892.5	113
1476	S1129	-5907.5	243

NO.	PAD NAME	X	Y
1477	S1130	-5922.5	113
1478	S1131	-5937.5	243
1479	S1132	-5952.5	113
1480	S1133	-5967.5	243
1481	S1134	-5982.5	113
1482	S1135	-5997.5	243
1483	S1136	-6012.5	113
1484	S1137	-6027.5	243
1485	S1138	-6042.5	113
1486	S1139	-6057.5	243
1487	S1140	-6072.5	113
1488	S1141	-6087.5	243
1489	S1142	-6102.5	113
1490	S1143	-6117.5	243
1491	S1144	-6132.5	113
1492	S1145	-6147.5	243
1493	S1146	-6162.5	113
1494	S1147	-6177.5	243
1495	S1148	-6192.5	113
1496	S1149	-6207.5	243
1497	S1150	-6222.5	113
1498	S1151	-6237.5	243
1499	S1152	-6252.5	113
1500	S1153	-6267.5	243
1501	S1154	-6282.5	113
1502	S1155	-6297.5	243
1503	S1156	-6312.5	113
1504	S1157	-6327.5	243
1505	S1158	-6342.5	113
1506	S1159	-6357.5	243
1507	S1160	-6372.5	113
1508	S1161	-6387.5	243
1509	S1162	-6402.5	113
1510	S1163	-6417.5	243
1511	S1164	-6432.5	113
1512	S1165	-6447.5	243
1513	S1166	-6462.5	113
1514	S1167	-6477.5	243
1515	S1168	-6492.5	113
1516	S1169	-6507.5	243
1517	S1170	-6522.5	113
1518	S1171	-6537.5	243
1519	S1172	-6552.5	113
1520	S1173	-6567.5	243
1521	S1174	-6582.5	113
1522	S1175	-6597.5	243
1523	S1176	-6612.5	113
1524	S1177	-6627.5	243
1525	S1178	-6642.5	113
1526	S1179	-6657.5	243
1527	S1180	-6672.5	113
1528	S1181	-6687.5	243
1529	S1182	-6702.5	113
1530	S1183	-6717.5	243
1531	S1184	-6732.5	113
1532	S1185	-6747.5	243
1533	S1186	-6762.5	113

NO.	PAD NAME	X	Y
1534	S1187	-6777.5	243
1535	S1188	-6792.5	113
1536	S1189	-6807.5	243
1537	S1190	-6822.5	113
1538	S1191	-6837.5	243
1539	S1192	-6852.5	113
1540	S1193	-6867.5	243
1541	S1194	-6882.5	113
1542	S1195	-6897.5	243
1543	S1196	-6912.5	113
1544	S1197	-6927.5	243
1545	S1198	-6942.5	113
1546	S1199	-6957.5	243
1547	S1200	-6972.5	113
1548	S1201	-6987.5	243
1549	S1202	-7002.5	113
1550	S1203	-7017.5	243
1551	S1204	-7032.5	113
1552	S1205	-7047.5	243
1553	S1206	-7062.5	113
1554	S1207	-7077.5	243
1555	S1208	-7092.5	113
1556	S1209	-7107.5	243
1557	S1210	-7122.5	113
1558	S1211	-7137.5	243
1559	S1212	-7152.5	113
1560	S1213	-7167.5	243
1561	S1214	-7182.5	113
1562	S1215	-7197.5	243
1563	S1216	-7212.5	113
1564	S1217	-7227.5	243
1565	S1218	-7242.5	113
1566	S1219	-7257.5	243
1567	S1220	-7272.5	113
1568	S1221	-7287.5	243
1569	S1222	-7302.5	113
1570	S1223	-7317.5	243
1571	S1224	-7332.5	113
1572	S1225	-7347.5	243
1573	S1226	-7362.5	113
1574	S1227	-7377.5	243
1575	S1228	-7392.5	113
1576	S1229	-7407.5	243
1577	S1230	-7422.5	113
1578	S1231	-7437.5	243
1579	S1232	-7452.5	113
1580	S1233	-7467.5	243
1581	S1234	-7482.5	113
1582	S1235	-7497.5	243
1583	S1236	-7512.5	113
1584	S1237	-7527.5	243
1585	S1238	-7542.5	113
1586	S1239	-7557.5	243
1587	S1240	-7572.5	113
1588	S1241	-7587.5	243
1589	S1242	-7602.5	113
1590	S1243	-7617.5	243

NO.	PAD NAME	X	Y
1591	S1244	-7632.5	113
1592	S1245	-7647.5	243
1593	S1246	-7662.5	113
1594	S1247	-7677.5	243
1595	S1248	-7692.5	113
1596	S1249	-7707.5	243
1597	S1250	-7722.5	113
1598	S1251	-7737.5	243
1599	S1252	-7752.5	113
1600	S1253	-7767.5	243
1601	S1254	-7782.5	113
1602	S1255	-7797.5	243
1603	S1256	-7812.5	113
1604	S1257	-7827.5	243
1605	S1258	-7842.5	113
1606	S1259	-7857.5	243
1607	S1260	-7872.5	113
1608	S1261	-7887.5	243
1609	S1262	-7902.5	113
1610	S1263	-7917.5	243
1611	S1264	-7932.5	113
1612	S1265	-7947.5	243
1613	S1266	-7962.5	113
1614	S1267	-7977.5	243
1615	S1268	-7992.5	113
1616	S1269	-8007.5	243
1617	S1270	-8022.5	113
1618	S1271	-8037.5	243
1619	S1272	-8052.5	113
1620	S1273	-8067.5	243
1621	S1274	-8082.5	113
1622	S1275	-8097.5	243
1623	S1276	-8112.5	113
1624	S1277	-8127.5	243
1625	S1278	-8142.5	113
1626	S1279	-8157.5	243
1627	S1280	-8172.5	113
1628	S1281	-8187.5	243
1629	S1282	-8202.5	113
1630	S1283	-8217.5	243
1631	S1284	-8232.5	113
1632	S1285	-8247.5	243
1633	S1286	-8262.5	113
1634	S1287	-8277.5	243
1635	S1288	-8292.5	113
1636	S1289	-8307.5	243
1637	S1290	-8322.5	113
1638	S1291	-8337.5	243
1639	S1292	-8352.5	113
1640	S1293	-8367.5	243
1641	S1294	-8382.5	113
1642	S1295	-8397.5	243
1643	S1296	-8412.5	113
1644	S1297	-8427.5	243
1645	S1298	-8442.5	113
1646	S1299	-8457.5	243
1647	S1300	-8472.5	113

NO.	PAD NAME	X	Y
1648	S1301	-8487.5	243
1649	S1302	-8502.5	113
1650	S1303	-8517.5	243
1651	S1304	-8532.5	113
1652	S1305	-8547.5	243
1653	S1306	-8562.5	113
1654	S1307	-8577.5	243
1655	S1308	-8592.5	113
1656	S1309	-8607.5	243
1657	S1310	-8622.5	113
1658	S1311	-8637.5	243
1659	S1312	-8652.5	113
1660	S1313	-8667.5	243
1661	S1314	-8682.5	113
1662	S1315	-8697.5	243
1663	S1316	-8712.5	113
1664	S1317	-8727.5	243
1665	S1318	-8742.5	113
1666	S1319	-8757.5	243
1667	S1320	-8772.5	113
1668	S1321	-8787.5	243
1669	S1322	-8802.5	113
1670	S1323	-8817.5	243
1671	S1324	-8832.5	113
1672	S1325	-8847.5	243
1673	S1326	-8862.5	113
1674	S1327	-8877.5	243
1675	S1328	-8892.5	113
1676	S1329	-8907.5	243
1677	S1330	-8922.5	113
1678	S1331	-8937.5	243
1679	S1332	-8952.5	113
1680	S1333	-8967.5	243
1681	S1334	-8982.5	113
1682	S1335	-8997.5	243
1683	S1336	-9012.5	113
1684	S1337	-9027.5	243
1685	S1338	-9042.5	113
1686	S1339	-9057.5	243
1687	S1340	-9072.5	113
1688	S1341	-9087.5	243
1689	S1342	-9102.5	113
1690	S1343	-9117.5	243
1691	S1344	-9132.5	113
1692	S1345	-9147.5	243
1693	S1346	-9162.5	113
1694	S1347	-9177.5	243
1695	S1348	-9192.5	113
1696	S1349	-9207.5	243
1697	S1350	-9222.5	113
1698	S1351	-9237.5	243
1699	S1352	-9252.5	113
1700	S1353	-9267.5	243
1701	S1354	-9282.5	113
1702	S1355	-9297.5	243
1703	S1356	-9312.5	113
1704	S1357	-9327.5	243

NO.	PAD NAME	X	Y
1705	S1358	-9342.5	113
1706	S1359	-9357.5	243
1707	S1360	-9372.5	113
1708	S1361	-9387.5	243
1709	S1362	-9402.5	113
1710	S1363	-9417.5	243
1711	S1364	-9432.5	113
1712	S1365	-9447.5	243
1713	S1366	-9462.5	113
1714	S1367	-9477.5	243
1715	S1368	-9492.5	113
1716	S1369	-9507.5	243
1717	S1370	-9522.5	113
1718	S1371	-9537.5	243
1719	S1372	-9552.5	113
1720	S1373	-9567.5	243
1721	S1374	-9582.5	113
1722	S1375	-9597.5	243
1723	S1376	-9612.5	113
1724	S1377	-9627.5	243
1725	S1378	-9642.5	113
1726	S1379	-9657.5	243
1727	S1380	-9672.5	113
1728	S1381	-9687.5	243
1729	S1382	-9702.5	113
1730	S1383	-9717.5	243
1731	S1384	-9732.5	113
1732	S1385	-9747.5	243
1733	S1386	-9762.5	113
1734	S1387	-9777.5	243
1735	S1388	-9792.5	113
1736	S1389	-9807.5	243
1737	S1390	-9822.5	113
1738	S1391	-9837.5	243
1739	S1392	-9852.5	113
1740	S1393	-9867.5	243
1741	S1394	-9882.5	113
1742	S1395	-9897.5	243
1743	S1396	-9912.5	113
1744	S1397	-9927.5	243
1745	S1398	-9942.5	113
1746	S1399	-9957.5	243
1747	S1400	-9972.5	113
1748	S1401	-9987.5	243
1749	S1402	-10002.5	113
1750	S1403	-10017.5	243
1751	S1404	-10032.5	113
1752	S1405	-10047.5	243
1753	S1406	-10062.5	113
1754	S1407	-10077.5	243
1755	S1408	-10092.5	113
1756	S1409	-10107.5	243
1757	S1410	-10122.5	113
1758	S1411	-10137.5	243
1759	S1412	-10152.5	113
1760	S1413	-10167.5	243
1761	S1414	-10182.5	113

NO.	PAD NAME	X	Y
1762	S1415	-10197.5	243
1763	S1416	-10212.5	113
1764	S1417	-10227.5	243
1765	S1418	-10242.5	113
1766	S1419	-10257.5	243
1767	S1420	-10272.5	113
1768	S1421	-10287.5	243
1769	S1422	-10302.5	113
1770	S1423	-10317.5	243
1771	S1424	-10332.5	113
1772	S1425	-10347.5	243
1773	S1426	-10362.5	113
1774	S1427	-10377.5	243
1775	S1428	-10392.5	113
1776	S1429	-10407.5	243
1777	S1430	-10422.5	113
1778	S1431	-10437.5	243
1779	S1432	-10452.5	113
1780	S1433	-10467.5	243
1781	S1434	-10482.5	113
1782	S1435	-10497.5	243
1783	S1436	-10512.5	113
1784	S1437	-10527.5	243
1785	S1438	-10542.5	113
1786	S1439	-10557.5	243
1787	S1440	-10572.5	113
1788	S1441	-10587.5	243
1789	S1442	-10602.5	113
1790	S1443	-10617.5	243
1791	S1444	-10632.5	113
1792	S1445	-10647.5	243
1793	S1446	-10662.5	113
1794	S1447	-10677.5	243
1795	S1448	-10692.5	113
1796	S1449	-10707.5	243
1797	S1450	-10722.5	113
1798	S1451	-10737.5	243
1799	S1452	-10752.5	113
1800	S1453	-10767.5	243
1801	S1454	-10782.5	113
1802	S1455	-10797.5	243
1803	S1456	-10812.5	113
1804	S1457	-10827.5	243
1805	S1458	-10842.5	113
1806	S1459	-10857.5	243
1807	S1460	-10872.5	113
1808	S1461	-10887.5	243
1809	S1462	-10902.5	113
1810	S1463	-10917.5	243
1811	S1464	-10932.5	113
1812	S1465	-10947.5	243
1813	S1466	-10962.5	113
1814	S1467	-10977.5	243
1815	S1468	-10992.5	113
1816	S1469	-11007.5	243
1817	S1470	-11022.5	113
1818	S1471	-11037.5	243

NO.	PAD NAME	X	Y
1819	S1472	-11052.5	113
1820	S1473	-11067.5	243
1821	S1474	-11082.5	113
1822	S1475	-11097.5	243
1823	S1476	-11112.5	113
1824	S1477	-11127.5	243
1825	S1478	-11142.5	113
1826	S1479	-11157.5	243
1827	S1480	-11172.5	113
1828	S1481	-11187.5	243
1829	S1482	-11202.5	113
1830	S1483	-11217.5	243
1831	S1484	-11232.5	113
1832	S1485	-11247.5	243
1833	S1486	-11262.5	113
1834	S1487	-11277.5	243
1835	S1488	-11292.5	113
1836	S1489	-11307.5	243
1837	S1490	-11322.5	113
1838	S1491	-11337.5	243
1839	S1492	-11352.5	113
1840	S1493	-11367.5	243
1841	S1494	-11382.5	113
1842	S1495	-11397.5	243
1843	S1496	-11412.5	113
1844	S1497	-11427.5	243
1845	S1498	-11442.5	113
1846	S1499	-11457.5	243
1847	S1500	-11472.5	113
1848	S1501	-11487.5	243
1849	S1502	-11502.5	113
1850	S1503	-11517.5	243
1851	S1504	-11532.5	113
1852	S1505	-11547.5	243
1853	S1506	-11562.5	113
1854	S1507	-11577.5	243
1855	S1508	-11592.5	113
1856	S1509	-11607.5	243
1857	S1510	-11622.5	113
1858	S1511	-11637.5	243
1859	S1512	-11652.5	113
1860	S1513	-11667.5	243
1861	S1514	-11682.5	113
1862	S1515	-11697.5	243
1863	S1516	-11712.5	113
1864	S1517	-11727.5	243
1865	S1518	-11742.5	113
1866	S1519	-11757.5	243
1867	S1520	-11772.5	113
1868	S1521	-11787.5	243
1869	S1522	-11802.5	113
1870	S1523	-11817.5	243
1871	S1524	-11832.5	113
1872	S1525	-11847.5	243
1873	S1526	-11862.5	113
1874	S1527	-11877.5	243
1875	S1528	-11892.5	113

NO.	PAD NAME	X	Y
1876	S1529	-11907.5	243
1877	S1530	-11922.5	113
1878	S1531	-11937.5	243
1879	S1532	-11952.5	113
1880	S1533	-11967.5	243

NO.	PAD NAME	X	Y
1881	S1534	-11982.5	113
1882	S1535	-11997.5	243
1883	S1536	-12012.5	113
1884	DUM_GND	-12055	258
1885	COM_PASSB	-12105	258

NO.	PAD NAME	X	Y
1886	COM_PASSB	-12155	258
1887	DUM_GND	-12205	258

7.4. Alignment Mark

--Alignment Mark coordinate

Left (-12131.5, 115.5)

Right (12131.5, 115.5)

--Alignment Mark size

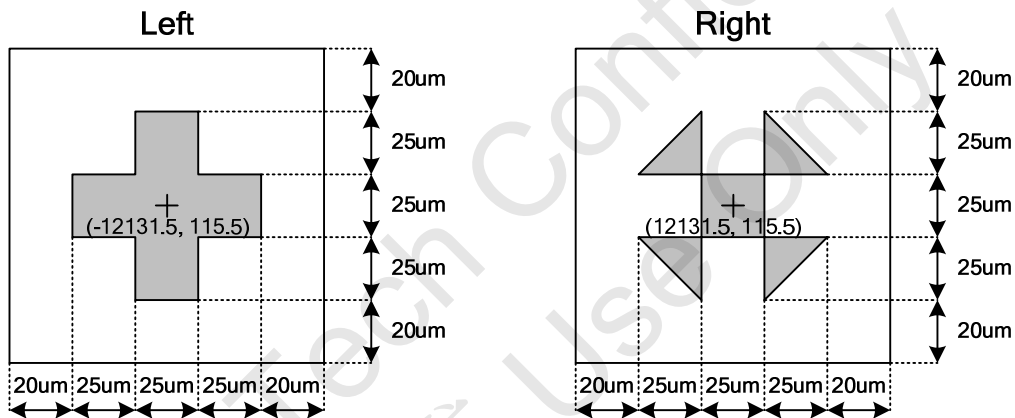

8. DISCLAIMER

The information appearing in this publication is believed to be accurate.

Integrated circuits sold by ORISE Technology are covered by the warranty and patent indemnification provisions stipulated in the terms of sale only. ORISE Technology makes no warranty, express, statutory implied or by description regarding the information in this publication or regarding the freedom of the described chip(s) from patent infringement. FURTHERMORE, ORISE Technology MAKES NO WARRANTY OF MERCHANTABILITY OR FITNESS FOR ANY PURPOSE. ORISE Technology reserves the right to halt production or alter the specifications and prices at any time without notice. Accordingly, the reader is cautioned to verify that the data sheets and other information in this publication are current before placing orders. Products described herein are intended for use in normal commercial applications. Applications involving unusual environmental or reliability requirements, e.g. military equipment or medical life support equipment, are specifically not recommended without additional processing by ORISE Technology for such applications. Please note that application circuits illustrated in this document are for reference purposes only.

ORISE Tech Confidential
For 瑞达威 Use Only

9. REVISION HISTORY

Date	Revision #	Description	Page	Auditor
FEB. 20, 2012	0.1	Original	48	Han.Chen

With collaboration of <https://www.displayfuture.com>