

**Features**

- Internal LCD drivers
 - 16 common signal drivers
 - 80 segment signal drivers
- Maximum display dimensions
 - 16 characters * 2 lines or
 - 32 characters * 1 line
- Interfaces with 4-bit or 8-bit MPU
- Versatile display functions provided on chip:
 - Display Clear, Cursor Home, Display ON/OFF, Cursor ON/OFF, Character Blinking, Cursor Shift, and Display Shift
- Three duty factors, selected by PROGRAM:
 - 1/8, 1/11, and 1/16
- Displays Data RAM (DD RAM): 80 X 8 bits (Displays up to 80 characters)
- Character Generator RAM (CG RAM):
 - 64 X 8 bits for general data,
 - 8 5 X 8 programmable dot patterns, or
 - 4 5 X 10 programmable dot patterns
- Low voltage reset
- ITO option for A-type and B-type LCD waveform
- Character Generator ROM (CG ROM):
 - 2 kinds of CG ROM sizes:
 - 192 characters:
 - 160 5 X 8 dot patterns
 - 32 5 X 10 dot patterns
 - 240 characters:
 - 192 5 X 8 dot patterns
 - 48 5 X 10 dot patterns
 - Custom CG ROM is also available
- Built-in power-on reset function
- Logic power supply: single +5V supply
- LCD driver power supply: V1~V5 ($V_{DD}+0.3 - V_{DD}-7.0$), divided by Built-in LCD power division resistor.
- Two oscillator operations (Freq. = 500KHz - 540KHz):
 - Built-in RC oscillation
 - External clock
- CMOS Process
- Available in COG FORM

General Description

The NT7603 is a dot matrix LCD controller and driver LSI that can operate with either a 4-bit or an 8-bit microprocessor (MPU). NT7603 receives control character codes from the MPU, stores them in an internal RAM (up to 80 characters), transforms each character code into a 5 X 7, 5 X 8, or 5 X 10 dot matrix character pattern, and then displays the codes on the LCD panel. The built-in Character Generator ROM consists of 256 different character patterns.

The NT7603 also contains Character Generator RAM where the user can store 8 different character patterns at run time. These memory features make character display flexible. NT7603 also provides many display instructions to achieve versatile LCD display functions. The NT7603 is fabricated on a single LSI chip using the CMOS process, resulting in very low power requirements.

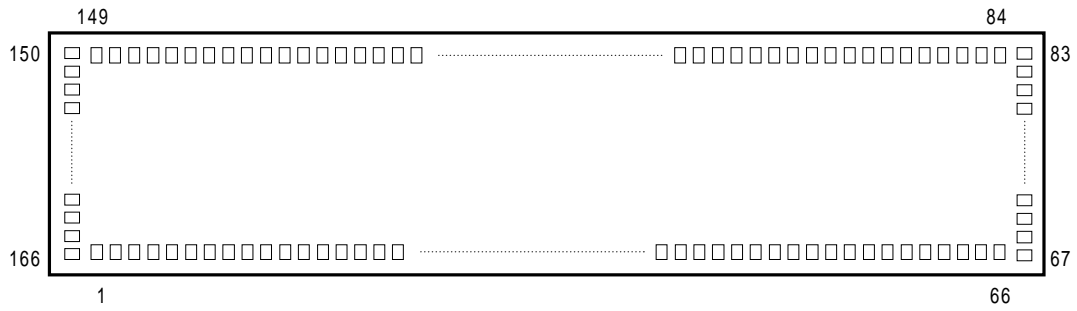
Pad Configuration

Item	Pad No.	Size		Unit
		X	Y	
Chip size	-	5156	1349	μm
Pad pitch	1- 166	70		

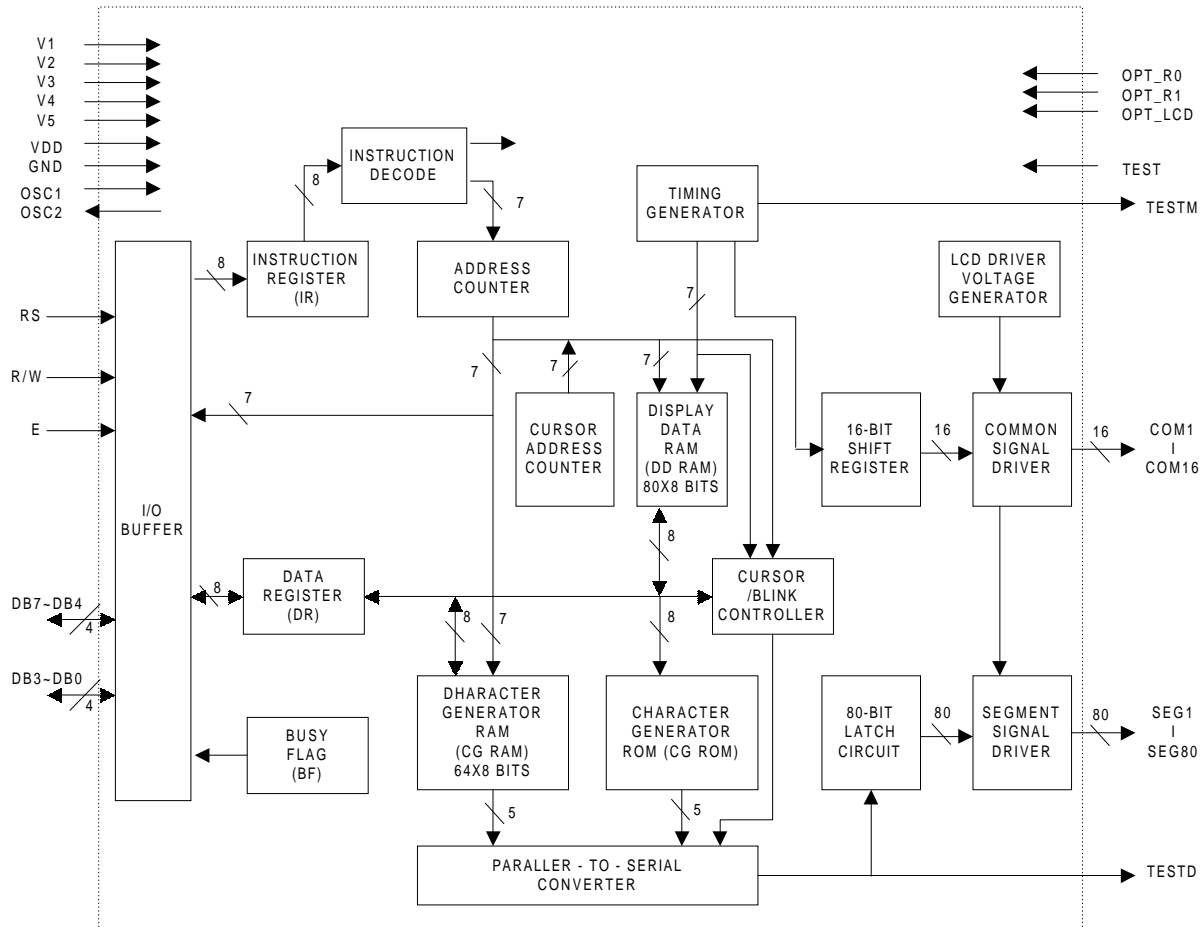
Block Diagram

Pad Description (Total 166 pads for COG type.)

Pad No.	Designation	I/O	External Connection	Description
1 – 15	GND	P	Power supply	GND: 0V
16	OSC1	I		For external clock operation, clock inputs to OSC1.
17	OSC2	O		Clock output.
18	V1	P	Power supply	Power supply for LCD driver. VDD ≥V1 ≥V2 ≥V3 ≥V4 ≥V5 ≥GND
19	V2	P	Power supply	Power supply for LCD driver
20	V3	P	Power supply	Power supply for LCD driver
21	V4	P	Power supply	Power supply for LCD driver
22 – 25	V5	P	Power supply	Power supply for LCD driver
26, 28	OPT_R0, OPT_R1	I	ITO Option	The built-in bias resistor select: OPT_R1, OPT_R0: No ITO=1. ITO on=0 1,1: 2.2KΩ; 1,0: 4KΩ; 0,1: 6.8KΩ; 0,0:No built-in bias resistor:
29 – 43	VDD	P	Power supply	VDD: +5V
44, 45	RS	I	MPU	Register select signal 0: Instruction register (write), Busy flag, address counter (read) 1: Data register (write, read)
46, 47	R/W	I	MPU	Read/Write control signal 0: Write 1: Read
48, 49	E	I	MPU	Read/Write start signal
50, 51	DB0	I/O	MPU	Lower 4 tri-state bi-directional data bus for transmitting data between MPU and NT7603. Not used during 4-bit operation.
52, 53	DB1			
54, 55	DB2			
56, 57	DB3			
58, 59	DB4	I/O	MPU	Higher 4 tri-state bi-directional data bus for transmitting data between MPU and NT7603. DB7 is also used as busy flag.
60, 61	DB5			
62, 63	DB6			
64, 65	DB7			
66	OPT_LCD	I	ITO Option	No ITO. (Option =1): B-Type waveform ITO On. (Option =0): A-Type waveform
68	TESTD	O	Test output	Test data output. (No connect for user)
164 – 157	COM1 – 8	O	LCD panel	Common signal output pins, for place on the upper glass (IC face up).
69 – 76,	COM9 – 16	O	LCD panel	
156 – 77	SEG1 – 80	O	LCD panel	Segment signal output pins
165	TEST	I	Test pin	Test pin internally pull-down. (No connect for user)
166	TESTM	O	Test output	LCD driver clock output. (No connect for user)
67, 27	GND_OUT	P		GND output pin, use for pull-down ITO option.

Functional Description

The NT7603 is dot-matrix LCD controller and driver LSI. It operates with either a 4-bit or an 8-bit microprocessor (MPU). The NT7603 receives both instructions and data from the MPU. Some instructions set operation modes, such as the function mode, data entry mode, and display mode; as well as some control LCD display functions, such as clear display, restore display, shift display, and cursor. Other instructions include read and write both data and addresses. All instructions allow users convenient and powerful functions to control the LCD dot-matrix displays.

Data is written into and read from the Data Display RAM (DD RAM) or the Character Generator RAM (CG RAM). As display character codes, the data stored in the DD RAM decodes a set of dot-matrix character patterns that are built into the Character Generator ROM (CG ROM). The CG ROM, with many character patterns (up to 256 patterns), defines the character pattern fonts. The NT7603 regularly scans the character patterns through the segment drivers. The CG RAM stores character pattern fonts at run time if users intend to show character patterns that are not defined in the CG ROM. This feature makes character display flexible. Other unused bytes can be used as general-purpose data storage.

The LCD driver circuit consists of 16 common signal drivers and 80 segment signal drivers allowing a variety of application configurations to be implemented.

Character Generator ROM (CG ROM)

The character generator ROM generates LCD dot character patterns from the 8-bit character pattern codes. The NT7603 provides 2 CG ROM configurations:

1. 192 Characters:

The CG ROM contains 160 5 X 8 dot character patterns and 32 5 X 10 dot character patterns, which the relation between the character codes and character patterns is shown in Table 1. The character codes from 00H to 0FH are used to get character patterns from the CG RAM. Character codes from 10H to 1FH and from 80H to 9FH map to full character patterns. Character codes from E0H to FFH are assigned to generate 5 X 10 dot character patterns, and other codes are used to generate 5x8 dot character patterns.

2. 240 Characters:

The CG ROM contains 192 5 X 8 dot character patterns and 48 5 X 10 dot character patterns, which the relation between the character codes and character patterns is shown in Table 2. The character codes from 00H to 0FH are used to get character patterns from the CG RAM. Character codes from 10H to 1FH and from E0H to FFH are assigned to generate 5 X 10 dot character patterns, and other codes to generate 5 X 8 dot character patterns. No null character pattern exists in this type. Note that the underlined cursor, displayed on the 8th duty may be obscure if the 8th row of a dot character pattern is coded. We recommend that users display the cursor in the blinking mode if they code 5x8 dot character patterns is their custom CG ROM.

Custom character patterns are available by mask-programming ROM. For convenience of character pattern development, NOVATEK has developed a user-friendly editor program for the NT7603 to help determine the character patterns users prefer. By executing the program on the computer, users can easily create and modify their character patterns. By transferring the resulting files generated by the program through a modem or some other communication method, the user and NOVATEK have established a reliable, fast link for programming the CG ROM.

Absolute Maximum Ratings*

Power Supply Voltage (V_{DD}) -0.3V to +7.0V
 Power Supply Voltage (V_1 to V_5)
 GND to $V_{DD}+0.3V$
 Input Voltage (V_i) -0.3V to $V_{DD} +0.3V$
 Operating Temperature (T_{OPR}) -20°C to +70°C
 Storage Temperature (T_{STG}) -55°C to +125°C

***Comments**

Stresses above those listed under "Absolute Maximum Ratings" may cause permanent damage to this device. These are stress ratings only. Functional operation of this device at these or any other conditions above those indicated in the operational sections of this specification is not implied or intended. Exposure to the absolute maximum rating conditions for extended periods may affect device reliability.

- All voltage values are referenced to GND = 0V
- V_1 to V_5 , must maintain $V_{DD} \geq V_1 \geq V_2 \geq V_3 \geq V_4 \geq V_5 \geq GND$.

DC Electrical Characteristics ($V_{DD} = 5.0V$, GND = 0V, $T_A = 25^\circ C$)

Symbol	Parameter	Min.	Typ.	Max.	Unit	Conditions	Applicable Pin
VDD	Operating Voltage	4.5	5.0	5.5	V		
V_{IH1}	"H" Level Input Voltage (1)	2.2	-	V_{DD}	V		DB0 – DB7, RS, R/W, E
V_{IL1}	"L" Level Input Voltage (1)	-0.3	-	0.8	V		
V_{IH2}	"H" Level Input Voltage (2)	$V_{DD} -1.0$	-	V_{DD}	V		OSC1
V_{IL2}	"L" Level Input Voltage (2)	GND	-	1.0	V		
V_{OH1}	"H" Level Output Voltage (1)	2.4	-	-	V	$I_{OH} = -0.25mA$	DB0 - DB7 (TTL)
V_{OL1}	"L" Level Output Voltage (1)	-	-	0.4	V	$I_{OL} = 1.2mA$	
V_{COM}	Driver Voltage Descending (COM)	-	-	0.3	V	$I_D = 5\mu A$	COM1 - 16
V_{SEG}	Driver Voltage Descending (SEG)	-	-	0.3	V	$I_D = 5\mu A$	SEG1 - 80
I_{IL}	Input Leakage Current	-1	-	1	μA	$V_{IN} = 0$ to V_{DD}	Not include OSCI
-IP	Pull-up MOS Current	50	125	250	μA	$V_{DD} = 5V$	RS, R/W, DB0-DB7
I_{OP}	Power Supply Current	-	1	1.5	mA	Rf oscillation, from external clock $V_{DD} = 5V$, $f_{osc} = f_{CP} =$ 540KHz, include LCD bias current.	V_{DD}

DC Electrical Character (continued)

Symbol	Parameter	Min.	Typ.	Max.	Unit	Conditions	Applicable Pin
External Clock Operation							
f _{CP}	External Clock Operating Frequency	250	540	700	KHz		
t _{DUTY}	External Clock Duty Cycle	45	50	55	%		
t _{RCP}	External Clock Rise Time	0.1	-	0.5	μs		
t _{FCP}	External Clock Fall Time	0.1	-	0.5	μs		
Internal Clock Operation (Built-in RC Oscillator)							
f _{OSC}	Oscillator Frequency	380	540	700	KHz	R _f = 50KΩ (reference only)	
V _{LCD1} V _{LCD2}	LCD Driving Voltage	3.0	-	V _{DD}	V	V _{DD} - V ₅	

AC Characteristics

 Read Cycle (V_{DD} = 5.0V, GND = 0V, T_A = 25°C)

Symbol	Parameter	Min.	Typ.	Max.	Unit	Conditions
t _{CYCE}	Enable Cycle Time	500	-	-	ns	Figure 1
t _{WHE}	Enable "H" Level Pulse Width	300	-	-	ns	Figure 1
t _{RE} , t _{FE}	Enable Rise/Fall Time	-	-	25	ns	Figure 1
t _{AS}	RS, R/W Setup Time	60 ¹	-	-	ns	Figure 1
		100 ²				
t _{AH}	RS, R/W Address Hold Time	10	-	-	ns	Figure 1
t _{RD}	Read Data Output Delay	-	-	190	ns	Figure 1
t _{DHR}	Read Data Hold Time	20	-	-	ns	Figure 1

AC Characteristics (continued)

 Write Cycle ($V_{DD} = 5.0V$, $GND = 0V$, $T_A = 25^\circ C$)

Symbol	Parameter	Min.	Typ.	Max.	Unit	Conditions
t _{CYCE}	Enable Cycle Time	500	-	-	ns	Figure 2
t _{WHE}	Enable "H" Level Pulse Width	300	-	-	ns	Figure 2
t _{RE} , t _{FE}	Enable Rise/Fall Time	-	-	25	ns	Figure 2
t _{AS}	RS, R/W Setup Time	60 ¹	-	-	ns	Figure 2
		100 ²				
t _{AH}	RS, R/W Address Hold Time	10	-	-	ns	Figure 2
t _{DS}	Data Output Delay	100	-	-	ns	Figure 2
t _{DHR}	Data Hold Time	10	-	-	ns	Figure 2

 Notes: 1: 8-bit operation mode
 2: 4-bit operation mode

Power Supply Conditions Using Internal Reset Circuit

Symbol	Parameter	Min.	Typ.	Max.	Unit	Conditions
t _{RON}	Power Supply Rise Time	0.1	-	10	ms	Figure 3
t _{OFF}	Power Supply OFF Time	1	-	-	ms	Figure 3

Timing Waveforms

Read Operation

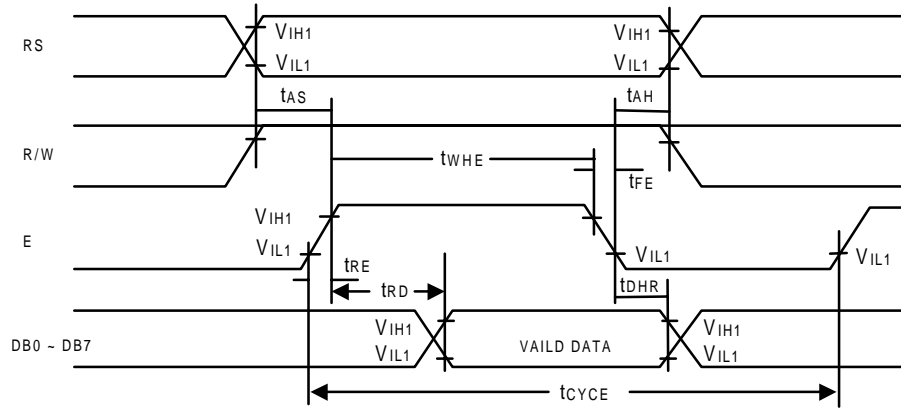

Figure 1. Bus Read Operation Sequence
(Reading out data from NT7603 to MPU)

Write Operation

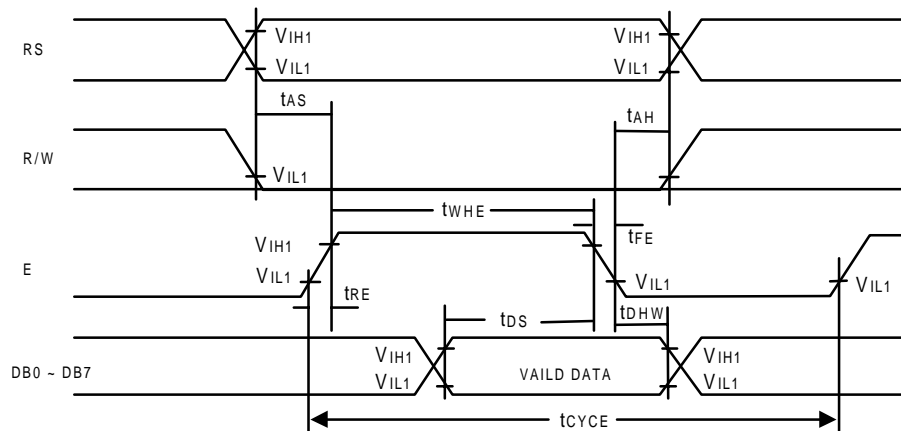

Figure 2. Bus Write Operation Sequence
(Writing out data from NT7603 to MPU)

Interface Signals with Segment Driver LSI

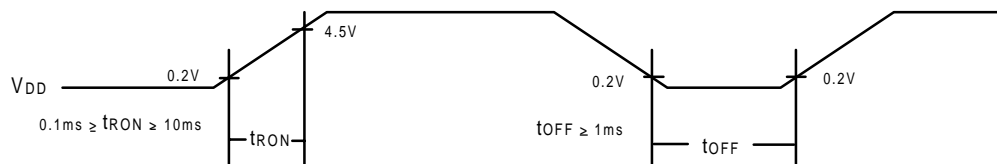
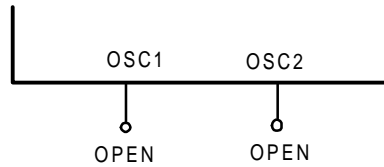

Figure 3. t_{OFF} stipulates the time of power ODD for instantaneous Power supply to or when power supply repeats ON and OFF.

Note 1: The NT7603 has two clock options:

A. Internal Oscillator (Built-in RC)



B. External Clock Operation

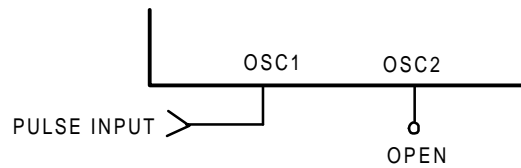

Note 2: Input/Output Terminals:

A. Input Terminal

Applicable Terminal: E (No Pull Up MOS)

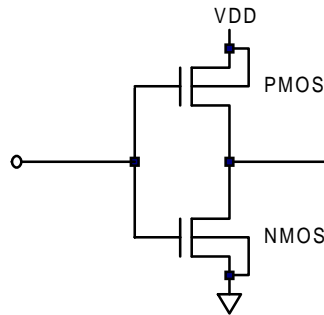

Applicable Terminal: RS, R/W (with Pull Up MOS)

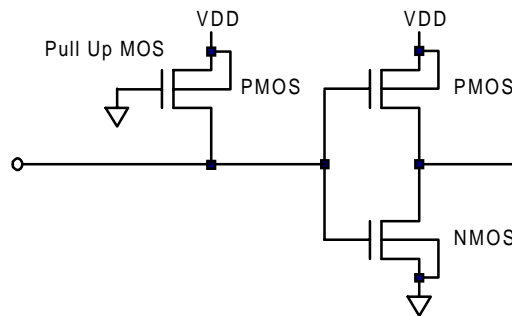

B. Output Terminal

Applicable Terminal: TESTM

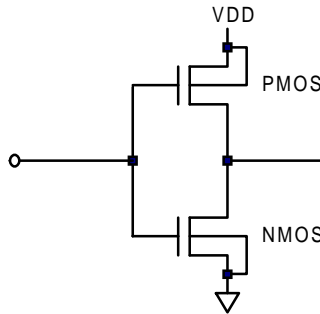
C. I/O Terminal

Applicable Terminal: DB0 to DB7

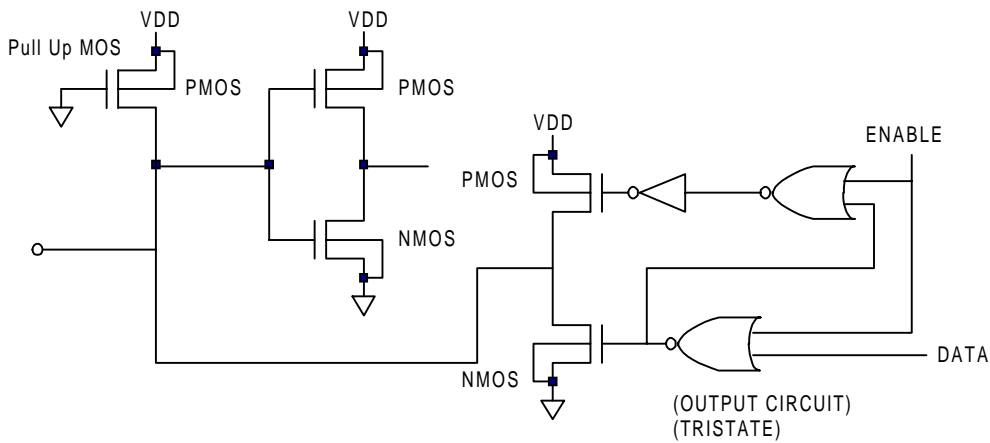
Note 3: ITO Options:

Set Option=0: Place ITO on the Option Pad.

Set Option=1: No ITO on the Option Pad.

No ITO:

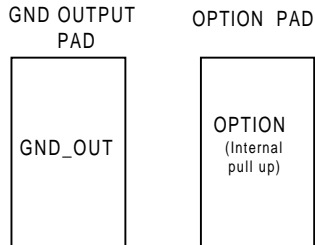

Option=1

ITO On:

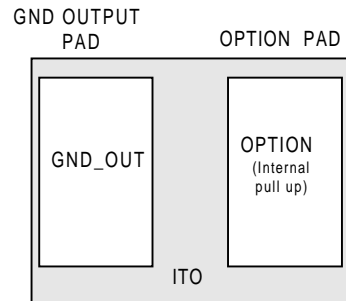

Option=0

**Table 1. NT7603-01 Correspondence between Character Codes and Character Patterns
(NOVATEK Standard 192 Character CG ROM)**

		Higher 4-bit (D4 to D7) of Character Code (Hexadecimal)																			
		0	1	2	3	4	5	6	7	8	9	A	B	C	D	E	F				
Lower 4-bit (D0 to D3) of Character Code (Hexadecimal)	0	CG RAM (1)			0	1	2	3	4	5	6	7	8	9	A	B	C	D	E	F	
	1	CG RAM (2)	!	1	A	Q	a	a													
	2	CG RAM (3)	"	2	B	R	b	r													
	3	CG RAM (4)	#	3	C	S	c	s													
	4	CG RAM (5)	\$	4	D	T	t	t													
	5	CG RAM (6)	%	5	E	U	e	u													
	6	CG RAM (7)	&	6	F	V	f	v													
	7	CG RAM (8)	'	7	G	W	g	w													
8	CG RAM (1)	(8	H	X	h	x														
9	CG RAM (2))	9	I	Y	i	y														
A	CG RAM (3)	*	A	J	Z	j	z														
B	CG RAM (4)	+	B	K	[k	[
C	CG RAM (5)	,	C	L]	l]														
D	CG RAM (6)	-	D	M	^	m	^														
E	CG RAM (7)	.	E	N	_	n	_														
F	CG RAM (8)	/	F	O	`	o	`														

Table 2. Example of 240 Character CG ROM

		Higher 4-bit (D4 to D7) of Character Code (Hexadecimal)															
		0	1	2	3	4	5	6	7	8	9	A	B	C	D	E	F
Lower 4 bit (D0 to D3) of Character Code (Hexadecimal)	0	CG RAM (1)	+		0	P	'	F	G	E	A	.	r	N	P	t	
	1	CG RAM (2)	=	!	1	A	Q	a	g	o	z	i	"	J	t	y	v
	2	CG RAM (3)	7	"	2	R	b	r	e	B	e	'	e	e	e	e	x
	3	CG RAM (4)	L	#	3	S	c	s	A	a	c	'	V	M	e	v	
	4	CG RAM (5)	7	*	4	T	d	t	a	b	t	'	e	n	z	o	
	5	CG RAM (6)	7	z	5	E	u	e	u	a	b	e	'	t	a	n	T
	6	CG RAM (7)	7	6	F	U	t	v	a	b	O	F	'	u	U	O	+
	7	CG RAM (8)	7	'	7	W	e	w	S	O	R	X	'	A	L	7	
	8	CG RAM (1)	7	C	B	X	H	x	e	g	e	'	+	+	E	K	+
	9	CG RAM (2)	7	9	I	Y	i	w	e	O	i	'	z	T	T	A	+
	A	CG RAM (3)	*	*	8	J	Z	z	e	O	A	Z	'	Z	P	F	
	B	CG RAM (4)	7	+	8	K	K	c	i	A	3	e	L	P	v	*	
	C	CG RAM (5)	=	.	<	L	\	l	l	i	N	8	*	U	B	z	
	D	CG RAM (6)	e	-	-	M	M	3	1	2	5	*	.	W	A		
	E	CG RAM (7)	#	.	>	N	n	'	A	2	2	'	U	O	O	P	
	F	CG RAM (8)	#	/	>	O	L	A	A	c	e	'	U	O	O	O	

Instruction Set

Instruction	Code										Function	Execution time (max) (f _{osc} = 250KHz)										
	RS	RW	DB7	DB6	DB5	DB4	DB3	DB2	DB1	DB0												
Display Clear	0	0	0	0	0	0	0	0	0	1	Clear entire display area.	1.64ms										
Display/ Cursor Home	0	0	0	0	0	0	0	0	1	*	Restore display from shift and load address counter with DD RAM address 00H.	1.64ms										
Entry Mode Set	0	0	0	0	0	0	0	1	I/D	S	Specify direction of cursor movement and display shift mode. This operation takes place after each data transfer (read/write).	40μs										
Display ON/OFF	0	0	0	0	0	0	1	D	C	B	Specify activation of display (D) cursor (C) and blinking of character at cursor position (B).	40μs										
Display/ Cursor Shift	0	0	0	0	0	1	S/C	R/L	*	*	Shift display or move cursor.	40μs										
Function Set	0	0	0	0	1	DL	N	F	*	*	Set interface data length (DL), number of display line (N), and character font (F).	40μs										
RAM Address Set	0	0	0	1	ACG						Load the address counter with a CG RAM address. Subsequent data access is for CG RAM data.	40μs										
DD RAM Address Set	0	0	1	ADD						Load the address counter with a DD RAM address. Subsequent data access is for DD RAM data.	40μs											
Busy Flag/ Address Counter Read	0	1	AC						Read Busy Flag (BF) and contents of Address Counter (AC).	40μs												
CG RAM/ DD RAM Data Write	1	0	Write data						Write data to CG RAM or DD RAM.	40μs												
CG RAM/ DD RAM Data Read	1	1	Read data						Read data from CG RAM or DD RAM.	40μs												
	I/D = 1 : Increment S = 1 : Display Shift On D = 1 : Display On C = 1 : Cursor Display On B = 1 : Cursor Blink On S/C = 1 : Shift Display R/L = 1 : Shift Right DL = 1 : 8-Bit N = 1 : Dual Line F = 1 : 5x10 dots BF = 1 : Internal Operation BF = 0 : Ready for Instruction										I/D = 0 : Decrement S/C = 0 : Move Cursor R/L = 0 : Shift Left DL = 0 : 4-Bit N = 0 : Signal Line F = 0 : 5x8 dots										DD RAM : Display Data RAM CG RAM : Character Generator RAM ACG : Character Generator RAM Address ADD : Display Data RAM Address AC : Address Counter	

Note 1: Symbol "*" signifies an insignificant bit (disregard).

Note 2: Correct input value for "N" is predetermined for each model.

Interface to LCD
(1) Character Font and Number of Lines

The NT7603 provide a 5 X 7 dot character font 1-line mode, a 5 X 10 dot character font 1-line mode and a 5 X 7 dot character font 2-line mode, as shown in the table below.

Three types of common signals are available as displayed in the table. The number of lines and the font type can be selected by the program.

Number of Lines	Character Font	Number of Common Signals	Duty Factor	Bias
1	5 X 7 dots + Cursor (or 5x8 dots)	8	1/8	1/4
1	5 X 10 dots + Cursor	11	1/11	1/4
2	5 X 7 dots + Cursor (or 5x8 dots)	16	1/16	1/5

(2) Connection to LCD

The following 4 LCD connection examples show the various combinations between characters and lines. NT7603 can directly drive the following combinations:

- (a) 5 X 8 Font - 16 character X 1 line (1/8 duty cycle, 1/4 bias)

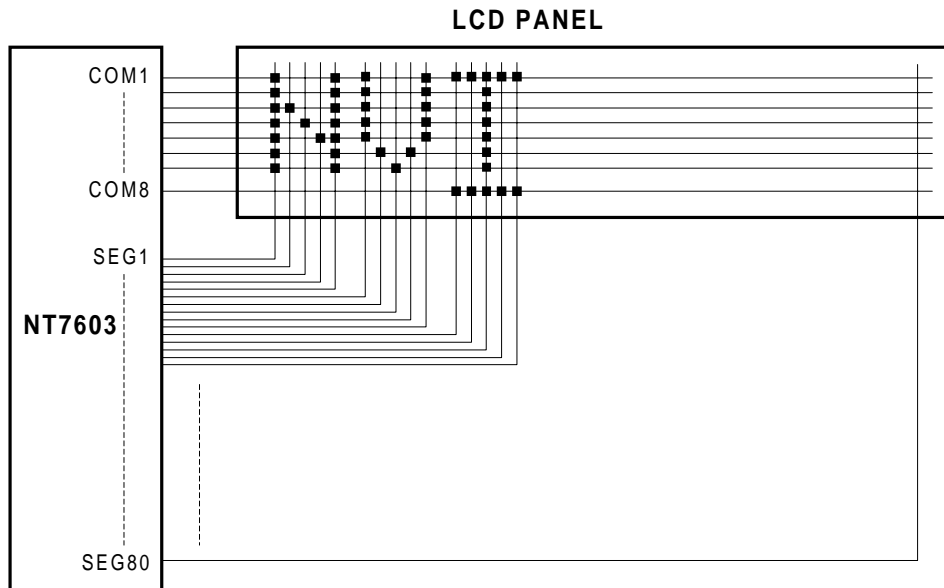

(b) 5 X 10 Font - 16 character X 1 line (1/11 duty cycle, 1/4 bias)

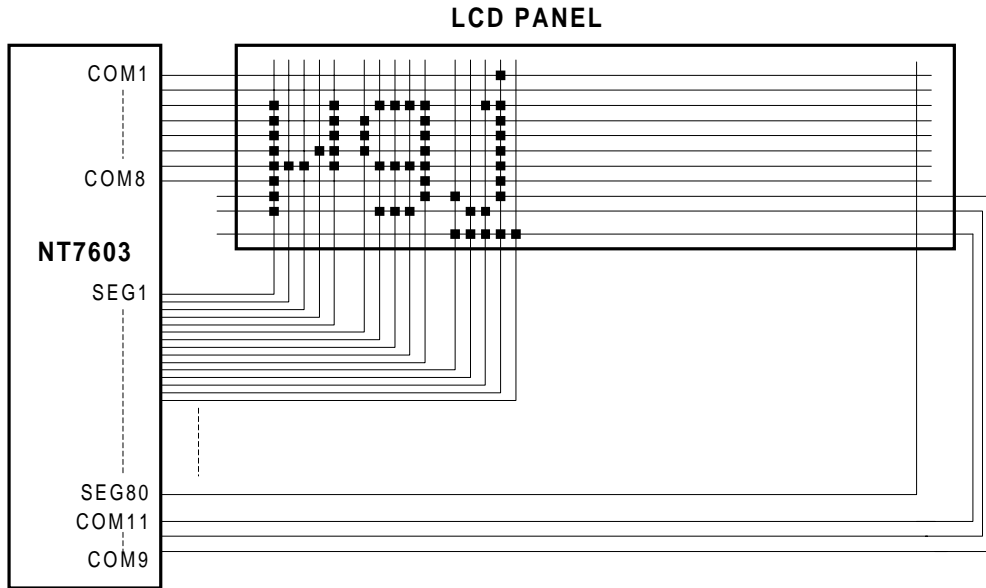

(c) 5 X 8 Font - 16 character X 2 line (1/16 duty cycle, 1/5 bias)

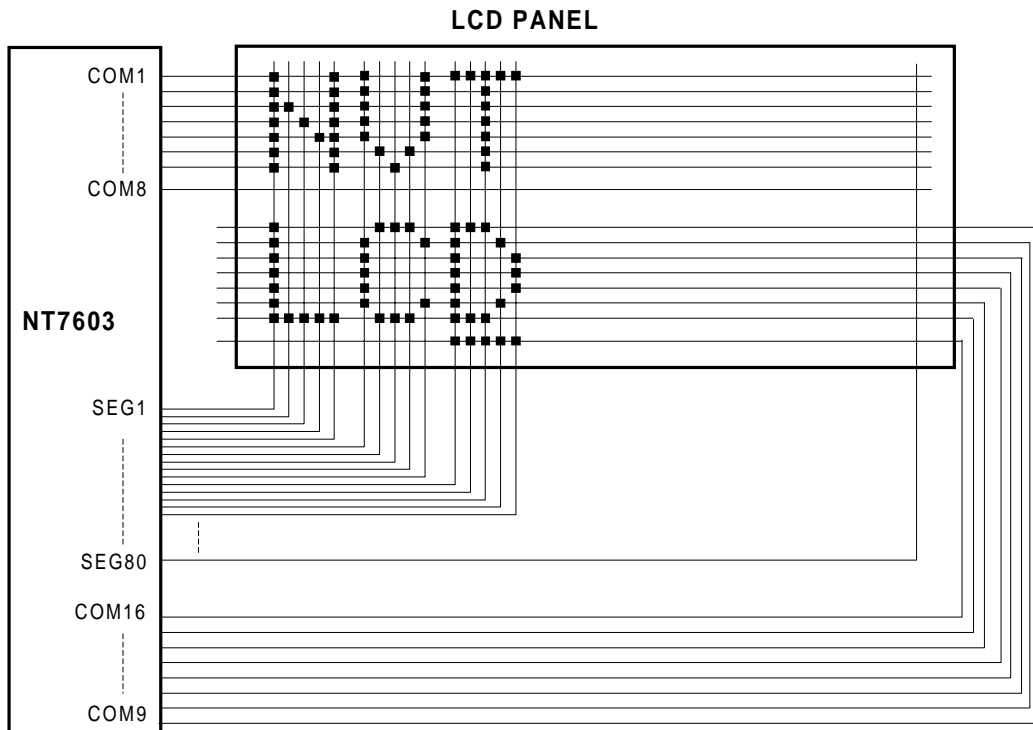

(d) 5 X 8 Font - 32 character X 1 line (1/16 duty cycle, 1/5bias)

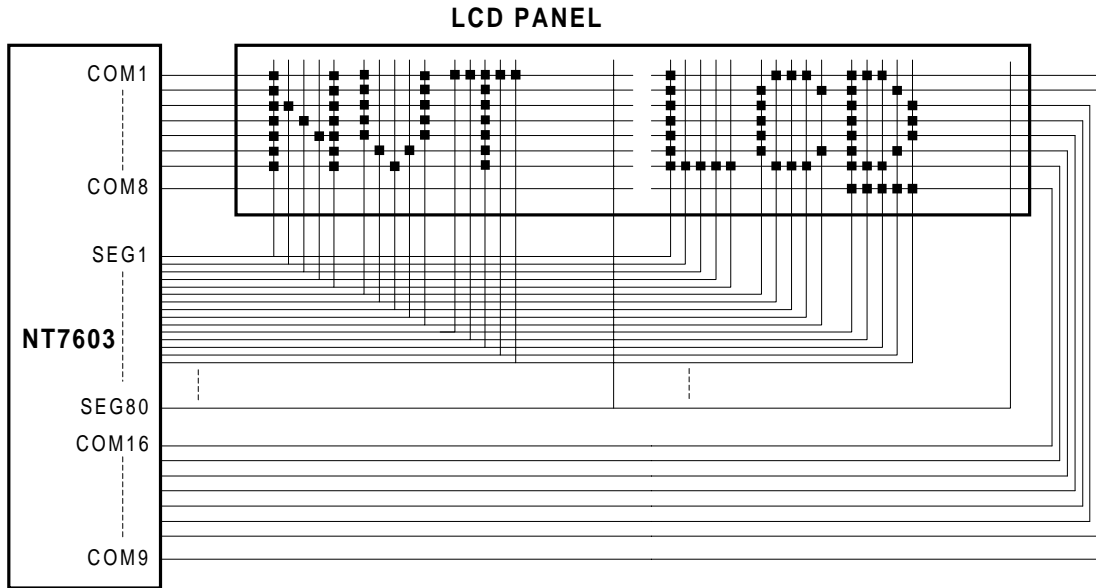

(3)Orientation type of NT7603:

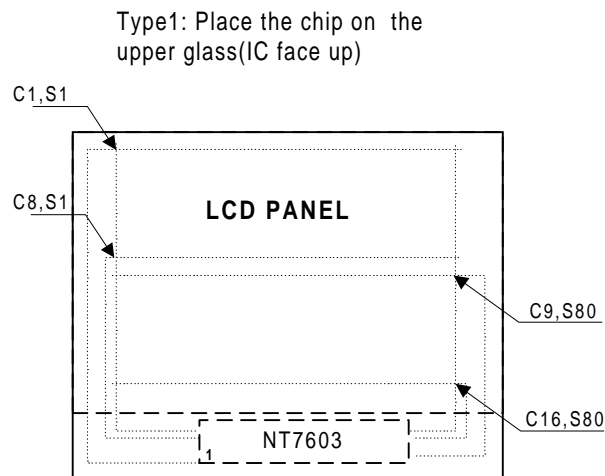

(3) Bias Power Connection

NT7603 provides 1/4 or 1/5 bias for various duty cycle applications. The built-in power division resistor divide voltage is described in the following table. The division resistor is The connection of NT7603, power supply, and resistors are also shown as follows:

Power Division	1/8, 1/11 Duty Cycle - 1/4 Bias	1/16 Duty Cycle - 1/5 Bias
V ₁	$V_{DD} - 1/4 V_{LCD}$	$V_{DD} - 1/5 V_{LCD}$
V ₂	$V_{DD} - 1/2 V_{LCD}$	$V_{DD} - 2/5 V_{LCD}$
V ₃	$V_{DD} - 1/2 V_{LCD}$	$V_{DD} - 3/5 V_{LCD}$
V ₄	$V_{DD} - 3/4 V_{LCD}$	$V_{DD} - 4/5 V_{LCD}$
V ₅	$V_{DD} - V_{LCD}$	$V_{DD} - V_{LCD}$

The bias is auto selected by duty cycle. When LCD is set to 1/16 duty, the bias is set to 1/5. Otherwise, the bias is set to 1/4.

The ITO Option can select the division resistor value:

OPT_R1	OPT_R0	Division Resistor
No ITO (1)	No ITO (1)	2.2KΩ
No ITO (1)	ITO On (0)	4KΩ
ITO On (0)	No ITO (1)	6.8KΩ
ITO On (0)	No ITO (0)	No built-in resistor (external input)

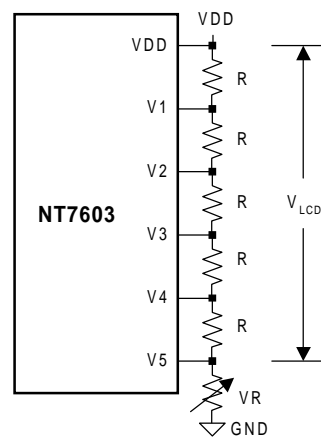
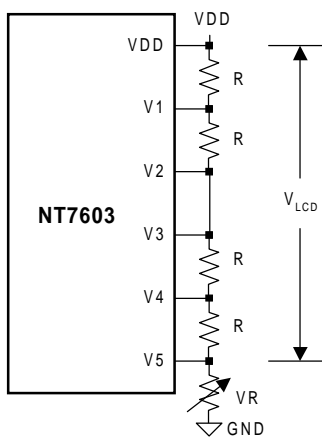
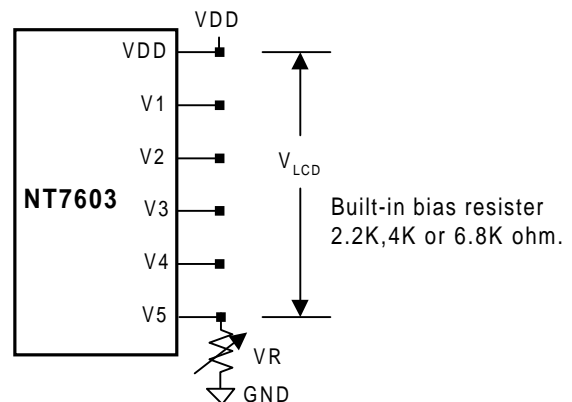

Exit Power division. (The resistance value depends on the LCD panel size.)

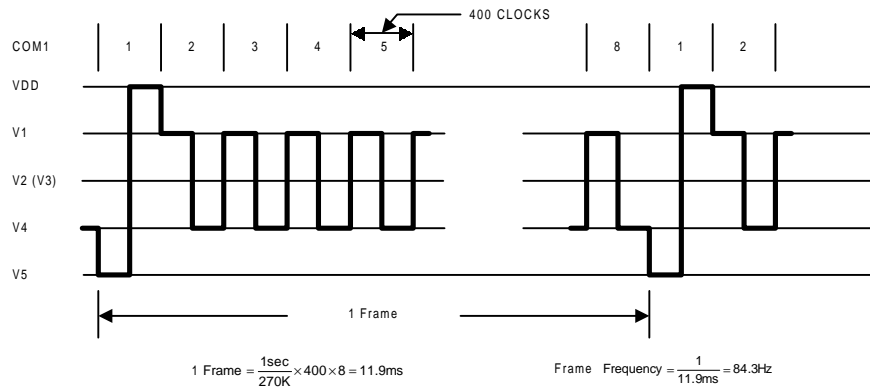
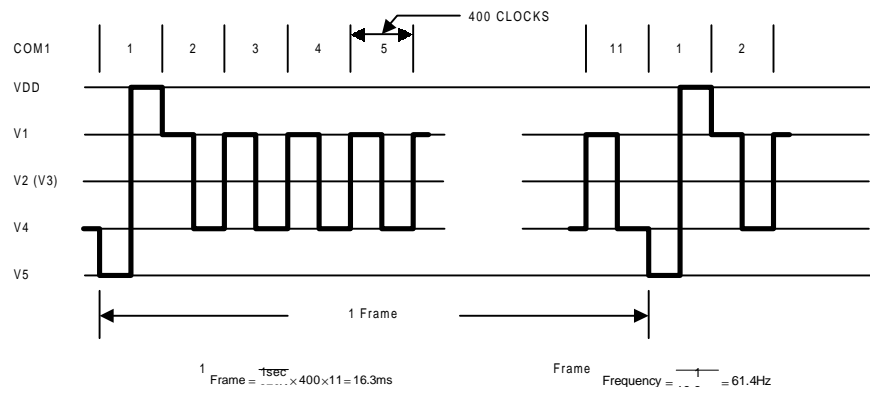
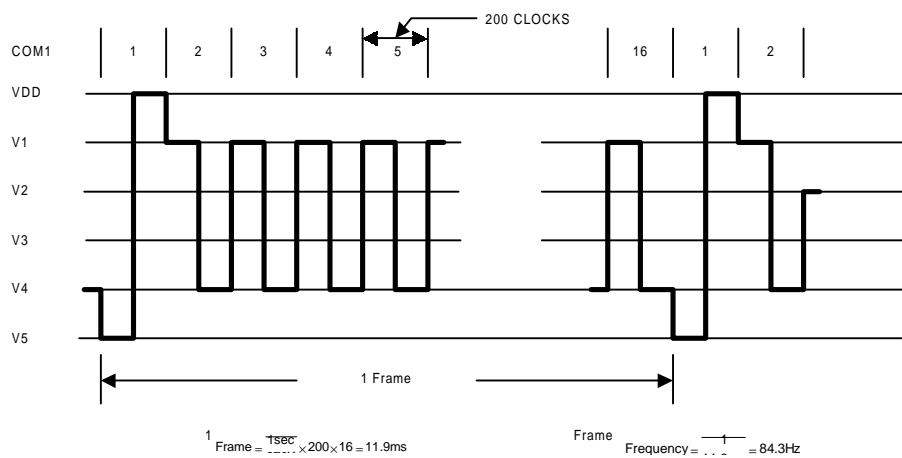
(4) LCD Waveform
A-type, 1/8 Duty Cycle, 1/4 Bias

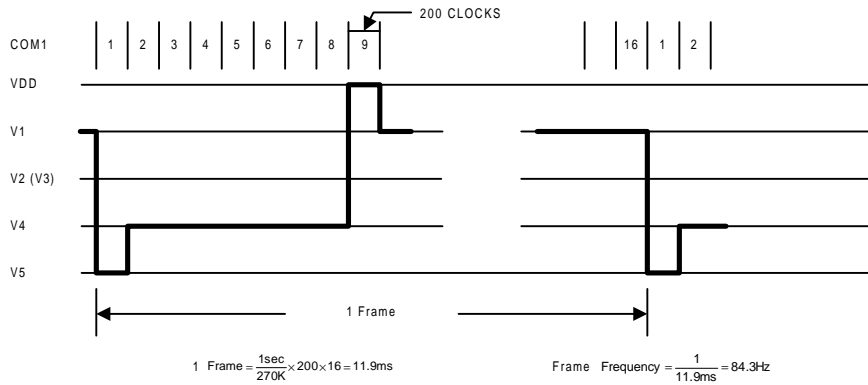
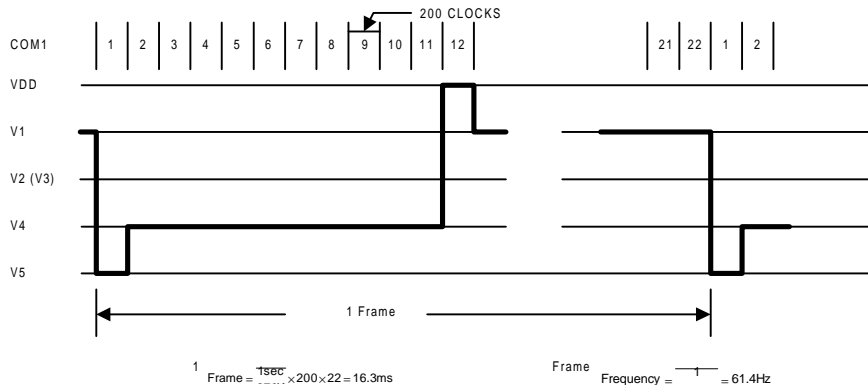
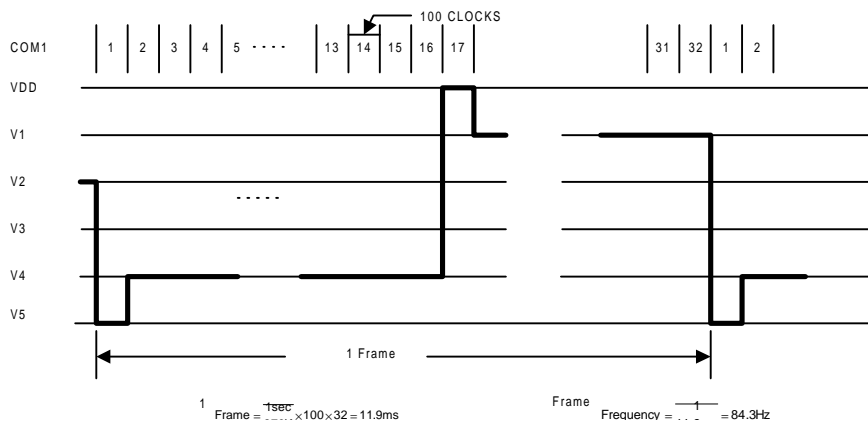
A-type, 1/11 Duty Cycle, 1/4 Bias

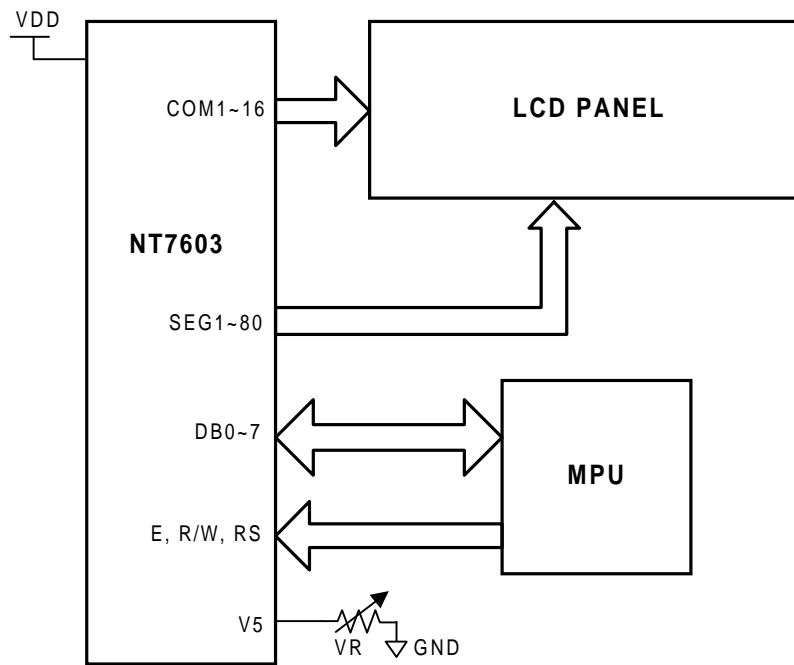
A-type, 1/16 Duty Cycle, 1/5 Bias

B-type, 1/8 Duty Cycle, 1/4 Bias

B-type, 1/11 Duty Cycle, 1/4 Bias

B-type, 1/16 Duty Cycle, 1/5 Bias

Application Circuit (for reference only)

Ordering Information

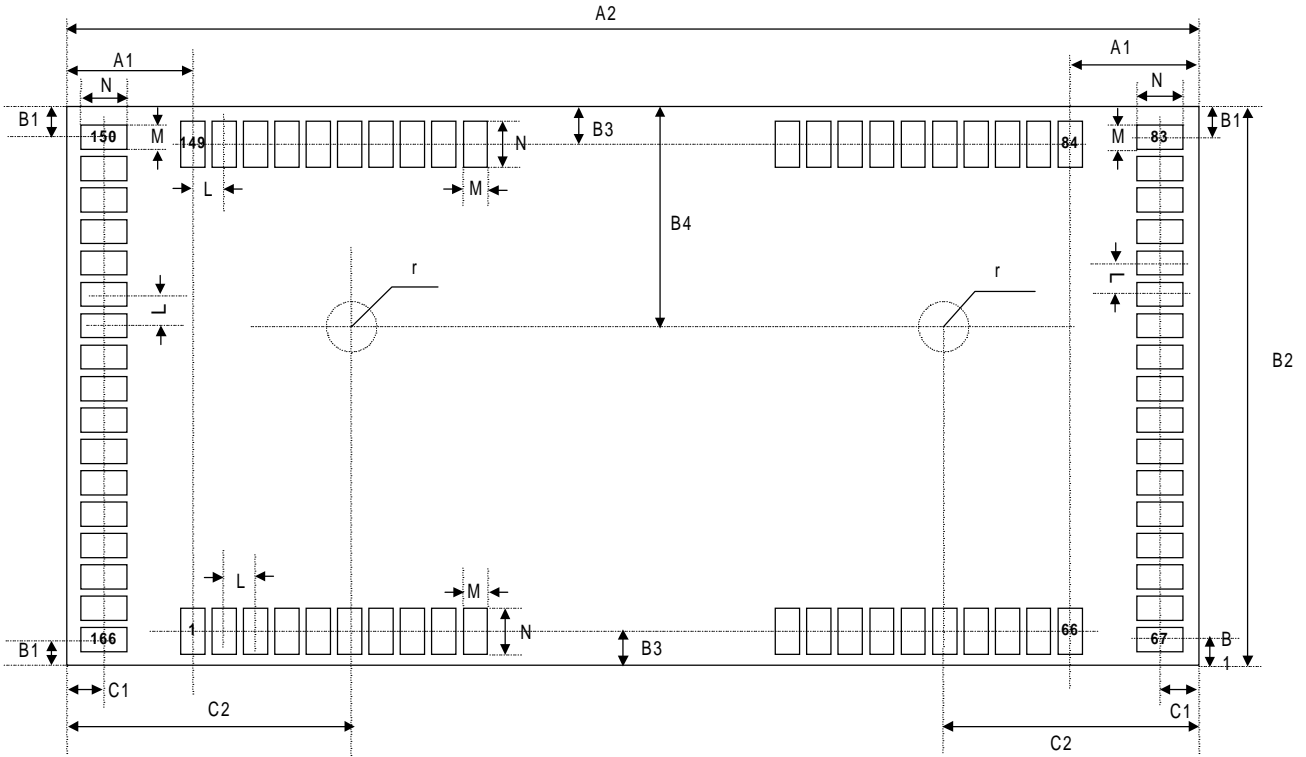
Part No.	CG ROM	Package	Shipment Style
NT7603BDB-01	192 CGROM (ref P12)	COG CHIP FORM	Bumped Die on Blue tape
NT7603BDT-01	192 CGROM (ref P12)	COG CHIP FORM	Bumped Die on chip Tray
NT7603BDW-01	192 CGROM (ref P12)	COG CHIP FORM	Bumped Die on Wafer

Pad Configuration of NT7603

 Unit: μm
 Chip Window: $1220 \times 5010 \mu\text{m}^2$

A1	230	C1	66
A2	5010	C2	511.55
B1	50	r	35
B2	1220	M	42
B3	70	N	90
B4	500.2	L	70

PAD Location

NO.	PAD NAME	X	Y	NO.	PAD NAME	X	Y
1	GND	-2275	-540	13	GND	-1435	-540
2	GND	-2205	-540	14	GND	-1365	-540
3	GND	-2135	-540	15	GND	-1295	-540
4	GND	-2065	-540	16	OSC1	-1225	-540
5	GND	-1995	-540	17	OSC2	-1155	-540
6	GND	-1925	-540	18	V1	-1085	-540
7	GND	-1855	-540	19	V2	-1015	-540
8	GND	-1785	-540	20	V3	-945	-540
9	GND	-1715	-540	21	V4	-875	-540
10	GND	-1645	-540	22	V5	-805	-540
11	GND	-1575	-540	23	V5	-735	-540
12	GND	-1505	-540	24	V5	-665	-540

NO.	PAD NAME	X	Y	NO.	PAD NAME	X	Y
25	V5	-595	-540	74	COM[14]	2439	-70
26	OPT_R0	-525	-540	75	COM[15]	2439	0
27	GND	-455	-540	76	COM[16]	2439	70
28	OPT_R1	-385	-540	77	SEG[80]	2439	140
29	VDD	-315	-540	78	SEG[79]	2439	210
30	VDD	-245	-540	79	SEG[78]	2439	280
31	VDD	-175	-540	80	SEG[77]	2439	350
32	VDD	-105	-540	81	SEG[76]	2439	420
33	VDD	-35	-540	82	SEG[75]	2439	490
34	VDD	35	-540	83	SEG[74]	2439	560
35	VDD	105	-540	84	SEG[73]	2275	540
36	VDD	175	-540	85	SEG[72]	2205	540
37	VDD	245	-540	86	SEG[71]	2135	540
38	VDD	315	-540	87	SEG[70]	2065	540
39	VDD	385	-540	88	SEG[69]	1995	540
40	VDD	455	-540	89	SEG[68]	1925	540
41	VDD	525	-540	90	SEG[67]	1855	540
42	VDD	595	-540	91	SEG[66]	1785	540
43	VDD	665	-540	92	SEG[65]	1715	540
44	RS	735	-540	93	SEG[64]	1645	540
45	RS	805	-540	94	SEG[63]	1575	540
46	RW	875	-540	95	SEG[62]	1505	540
47	RW	945	-540	96	SEG[61]	1435	540
48	E	1015	-540	97	SEG[60]	1365	540
49	E	1085	-540	98	SEG[59]	1295	540
50	DB[0]	1155	-540	99	SEG[58]	1225	540
51	DB[0]	1225	-540	100	SEG[57]	1155	540
52	DB[1]	1295	-540	101	SEG[56]	1085	540
53	DB[1]	1365	-540	102	SEG[55]	1015	540
54	DB[2]	1435	-540	103	SEG[54]	945	540
55	DB[2]	1505	-540	104	SEG[53]	875	540
56	DB[3]	1575	-540	105	SEG[52]	805	540
57	DB[3]	1645	-540	106	SEG[51]	735	540
58	DB[4]	1715	-540	107	SEG[50]	665	540
59	DB[4]	1785	-540	108	SEG[49]	595	540
60	DB[5]	1855	-540	109	SEG[48]	525	540
61	DB[5]	1925	-540	110	SEG[47]	455	540
62	DB[6]	1995	-540	111	SEG[46]	385	540
63	DB[6]	2065	-540	112	SEG[45]	315	540
64	DB[7]	2135	-540	113	SEG[44]	245	540
65	DB[7]	2205	-540	114	SEG[43]	175	540
66	OPT_LCD	2275	-540	115	SEG[42]	105	540
67	GND	2439	-560	116	SEG[41]	35	540
68	TESTD	2439	-490	117	SEG[40]	-35	540
69	COM[9]	2439	-420	118	SEG[39]	-105	540
70	COM[10]	2439	-350	119	SEG[38]	-175	540
71	COM[11]	2439	-280	120	SEG[37]	-245	540
72	COM[12]	2439	-210	121	SEG[36]	-315	540
73	COM[13]	2439	-140	122	SEG[35]	-385	540

NO.	PAD NAME	X	Y	NO.	PAD NAME	X	Y
123	SEG[34]	-455	540	146	SEG[11]	-2065	540
124	SEG[33]	-525	540	147	SEG[10]	-2135	540
125	SEG[32]	-595	540	148	SEG[9]	-2205	540
126	SEG[31]	-665	540	149	SEG[8]	-2275	540
127	SEG[30]	-735	540	150	SEG[7]	-2439	560
128	SEG[29]	-805	540	151	SEG[6]	-2439	490
129	SEG[28]	-875	540	152	SEG[5]	-2439	420
130	SEG[27]	-945	540	153	SEG[4]	-2439	350
131	SEG[26]	-1015	540	154	SEG[3]	-2439	280
132	SEG[25]	-1085	540	155	SEG[2]	-2439	210
133	SEG[24]	-1155	540	156	SEG[1]	-2439	140
134	SEG[23]	-1225	540	157	COM[8]	-2439	70
135	SEG[22]	-1295	540	158	COM[7]	-2439	0
136	SEG[21]	-1365	540	159	COM[6]	-2439	-70
137	SEG[20]	-1435	540	160	COM[5]	-2439	-140
138	SEG[19]	-1505	540	161	COM[4]	-2439	-210
139	SEG[18]	-1575	540	162	COM[3]	-2439	-280
140	SEG[17]	-1645	540	163	COM[2]	-2439	-350
141	SEG[16]	-1715	540	164	COM[1]	-2439	-420
142	SEG[15]	-1785	540	165	TEST	-2439	-490
143	SEG[14]	-1855	540	166	TESTM	-2439	-560
144	SEG[13]	-1925	540		ALK_L	-1993.45	109.8
145	SEG[12]	-1995	540		ALK_R	1993.45	109.8

With collaboration of <https://www.displayfuture.com>