



DATA SHEET

(DOC No. HX8264-D02-DS)

HX8264-D02

1200 CH TFT LCD Source Driver
with TCON

Version 01 April, 2010

1. General Description	5
2. Features	5
3. Block Diagram	6
3.1 Function block diagram	6
3.2 Application block diagram	7
3.2.1 Single chip application	7
3.2.2 Two chip cascade application	9
3.2.3 Dual gate application	15
4. Pin Description	21
5. Operation Description	25
5.1 Relationship between input data and output channels	25
5.2 HX8264-D02 configuration table	27
5.3 The BIST Pattern for Aging Mode Test	29
6. Gamma Adjustment Function	30
6.1 Relationship between gamma correction and output voltage	30
7. CABC (Content Adaptive Brightness Control)	45
7.1 CABC Hardware Control	46
7.2 CABC Software SPI Control	46
7.3 Command Description	47
8. 3-wire Serial Peripheral Interface (SPI)	51
9. Power on/off Sequence	52
9.1 Power on/off control	52
9.2 Enter and exit standby mode sequence	52
10. DC Characteristics	53
10.1 Absolute maximum rating (VSS=0V)	53
10.2 DC electrical characteristics (VSS=0V, TA=25°C)	53
11. AC Characteristics	54
11.1 AC electrical characteristics	54
11.2 Data input format	55
11.2.1 Resolution : 800x480	56
11.2.2 Resolution : 800x600	57
11.2.3 Resolution : 640x480	58
11.2.4 Resolution : 400x240	59
12. Waveform	60
12.1 Timing waveform table	60
12.1.1 Parallel 24-bit RGB mode	60
12.2 Timing diagram	61
12.2.1 Input clock and data timing waveform	61
12.2.2 Source output timing waveform (Cascade)	61
12.2.3 Vertical timing diagram HV (Cascade)	62
12.2.4 Vertical timing diagram DE (Cascade)	62
12.2.5 Gate output timing diagram (Cascade)	62
12.2.6 Vertical timing diagram HV (Dual gate)	63
12.2.7 Vertical timing diagram DE (Dual gate)	63
12.2.8 Gate output timing diagram (Dual gate)	63
13. Pin Assignment (IC Face View)	64
14. Package Outline	65
14.1 Pad coordinates	68
15. Ordering Information	84
16. Revision History	84

Figure 3. 1 HX8264-D02 Function Block Diagram	6
Figure 3. 2 HX8264-D02 Single Chip 400(RGB) x 240 Application Block Diagram-1	7
Figure 3. 3 HX8264-D02 Single Chip 400(RGB) x 240 Application Block Diagram-2	8
Figure 3. 6 HX8264-D02 Two Chip Cascade 800(RGB) x 480 Application Block Diagram-1	9
Figure 3. 7 HX8264-D02 Two Chip Cascade 800(RGB) x 480 Application Block Diagram-2	10
Figure 3. 8 HX8264-D02 Two Chip Cascade 800(RGB) x 600 Application Block Diagram-1	11
Figure 3. 9 HX8264-D02 Two Chip Cascade 800(RGB) x 600 Application Block Diagram-2	12
Figure 3. 8 HX8264-D02 Two Chip Cascade 640(RGB) x 480 Application Block Diagram-1	13
Figure 3. 9 HX8264-D02 Two Chip Cascade 640(RGB) x 480 Application Block Diagram-2	14
Figure 3. 10 HX8264-D02 Dual Gate 800(RGB) x 480 Application Block Diagram-1	15
Figure 3. 11 HX8264-D02 Dual Gate 800(RGB) x 480 Application Block Diagram-2	16
Figure 3. 12 HX8264-D02 Dual Gate 800(RGB) x 600 Application Block Diagram-1	17
Figure 3. 13 HX8264-D02 Dual Gate 800(RGB) x 600 Application Block Diagram-2	18
Figure 3. 14 HX8264-D02 Dual Gate 640(RGB) x 480 Application Block Diagram-1	19
Figure 3. 15 HX8264-D02 Dual Gate 640(RGB) x 480 Application Block Diagram-2	20
Figure 6. 1 Gamma Correction Characteristic Curve	30
Figure 7. 1 Power on/off Timing Sequence	52
Figure 7. 2 Enter and Exit Standby Mode Sequence	52
Figure 9. 1 Horizontal Input Timing Diagram	55
Figure 9. 2 Vertical Input Timing Diagram	55
Figure 10. 1 Input Clock and Data Timing Diagram	61
Figure 10. 2 Source Output Timing Diagram	61
Figure 10. 3 Output Load Condition	61
Figure 10. 4 Vertical Timing Diagram HV (Cascade)	62
Figure 10. 5 Vertical Timing Diagram DE (Cascade)	62
Figure 10. 6 Gate Output Timing Diagram (Cascade)	62
Figure 10. 7 Vertical Timing Diagram HV (Dual Gate)	63
Figure 10. 8 Vertical Timing Diagram DE (Dual Gate)	63
Figure 10. 9 Gate Output Timing Diagram (Dual Gate)	63
Figure 11. 1 Pin Assignment	64
Figure 12. 1 Package Outline	66
Figure 12. 2 Alignment Mark	67

List of Tables

April, 2010

Table 4. 1 HX8264-D02 Pass Line Description	24
Table 4. 2 The Recommended Wiring Resistance Values	24
Table 5. 1 HX8264-D02 DATR[17:0] Pin Mapping Table	27
Table 5. 2 HX8264-D02 DATL[17:0] Pin Mapping Table	28
Table 10. 1 Parallel 24-bit RGB mode.....	60
Table 12. 1 Pad Information	67

Himax Confidential
Do Not Copy

1. General Description

HX8264-D02 is a highly integrated 1200 channel outputs source driver with TTL interface Timing Controller for color TFT-LCD panels. HX8264-D02 integrated source driver, timing controller and pin control interface.

Input timing supports TTL digital 24-bit parallel RGB data format, and source output supports 16M colors with dithering features. Operating parameters can be set via pin control for all control features. Special circuit architecture is designed for low power dissipation.

HX8264-D02 supports two chip cascade operation mode to reduce the FPC amount and save the cost. Configurable Master and Slave configuration increase the flexibility for different panel design. With wide range of supply voltages and small output deviations make this chip more suitable for various applications.

HX8264-D02 supports single or double gate operation mode.

2. Features

- Special design for small-sized color TFT LCD source drivers with timing controller
- Integrated 1200 channel source driver
- Support display resolutions: 800(RGB) x600, 800(RGB) x480, 640(RGB) x480, 400(RGB) x240
- Support 16M colors with 2-bits dithering
- Support TTL 24-bit parallel (RGB) input timing
- Support data inverted function for normally black LCD
- Support 2 gamma curve for normally white or normally black LCD
- Support content adaptive brightness control (CABC) function
- Support cascade function with bidirectional shift control (CMOS signal)
- Support single or dual-gate operation mode
- Support delta or stripe color filter configuration
- Support stand-by mode for low power consumption
- Support dot inversion driving scheme for single gate operation mode
- V1~V14 for adjusting Gamma correction
- Output dynamic range: 0.1~VDDA-0.1V
- Power for source driver voltage VDDA: 6.5V~13.5V
- Power for digital interface circuit VDD: 2.7 ~ 3.6V
- Operating frequency: 50MHz (Max.)
- COG package

3. Block Diagram

3.1 Function block diagram

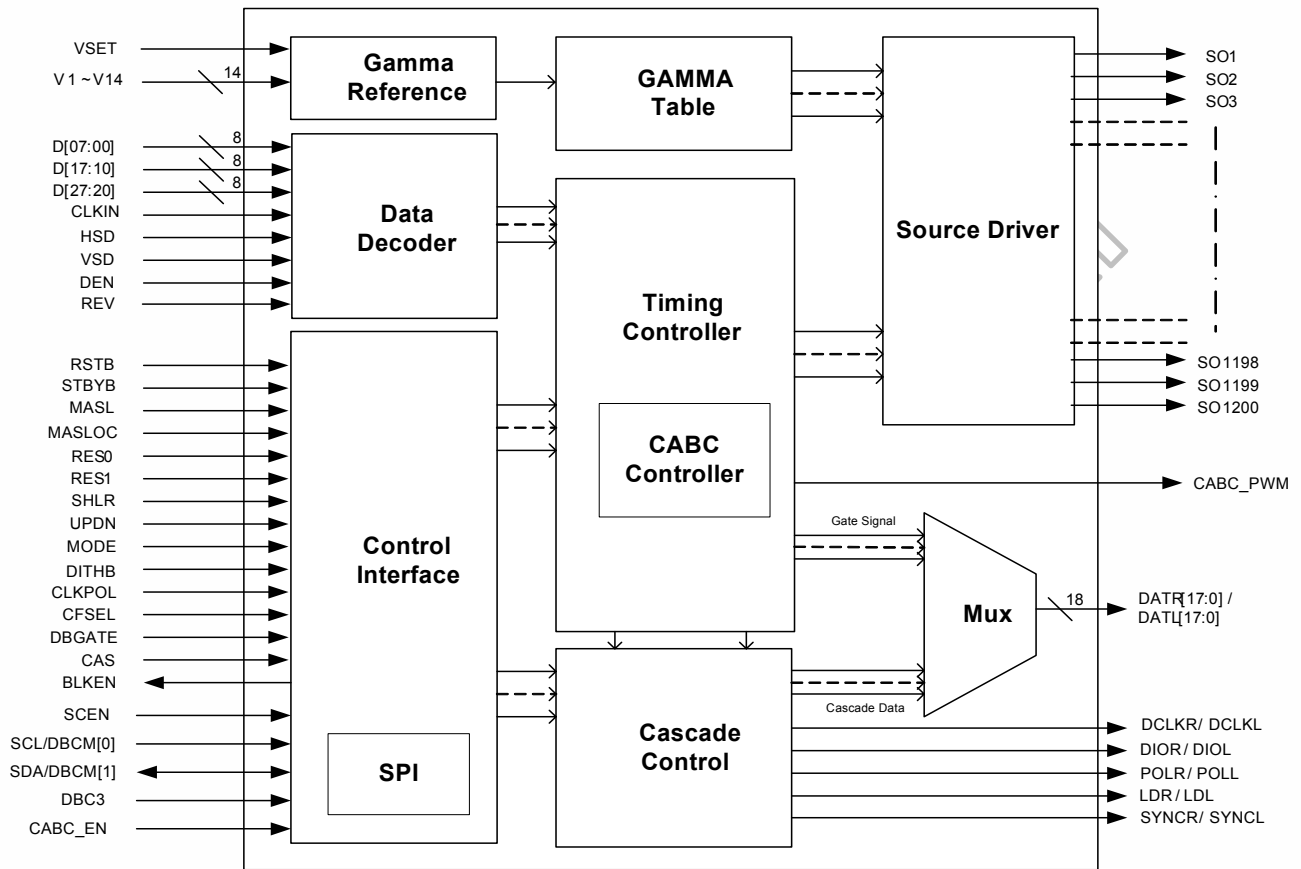

Figure 3.1 HX8264-D02 Function Block Diagram

3.2 Application block diagram

3.2.1 Single chip application

a. 400(RGB) x 240 (Gate driver on left side)

RES [1:0]=11
CAS=0
DBGATE=0

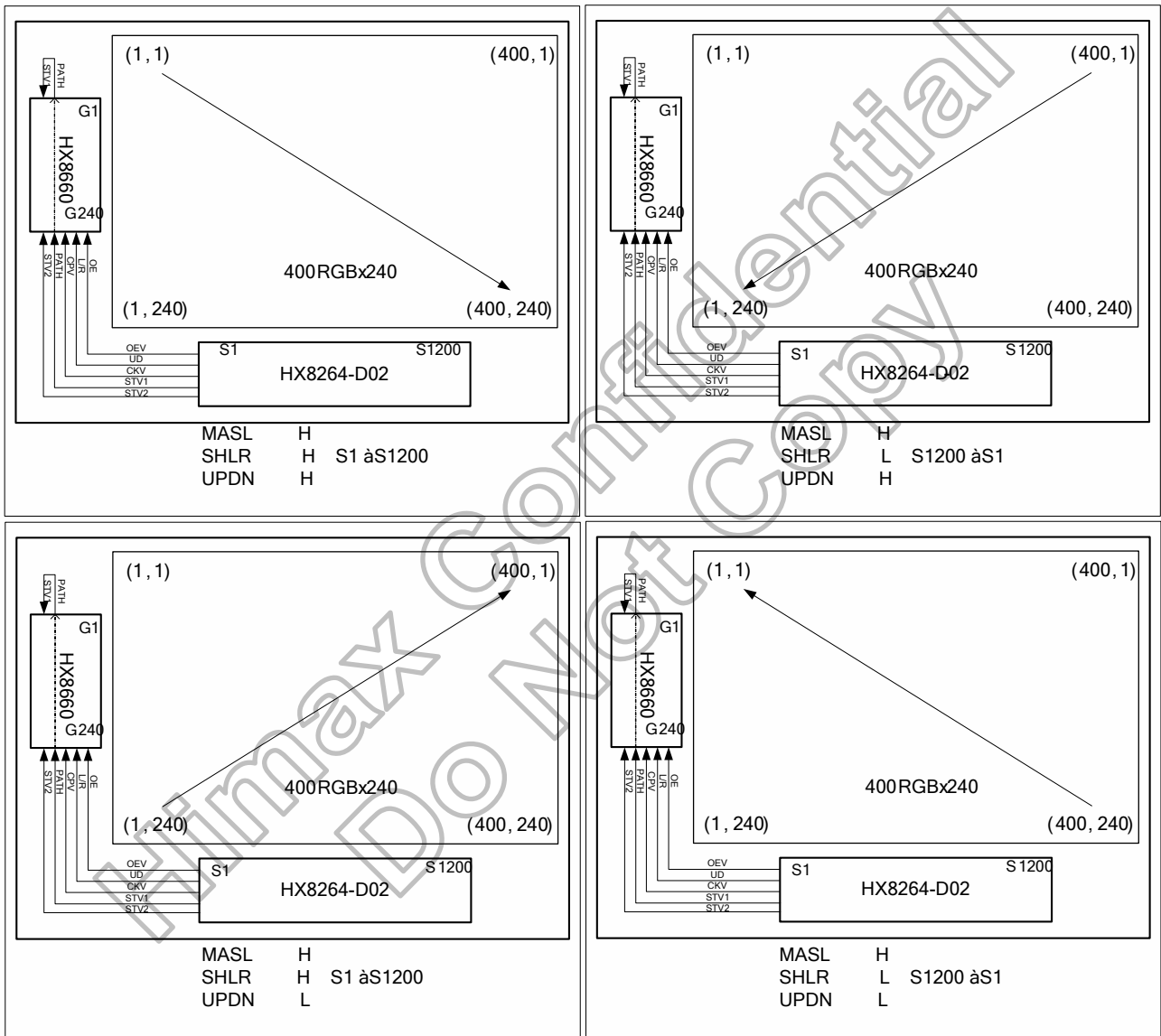

Figure 3. 2 HX8264-D02 Single Chip 400(RGB) x 240 Application Block Diagram-1

b. 400(RGB) x 240 (Gate driver on right side)

RES [1:0]=11
 CAS=0
 DBGATE=0

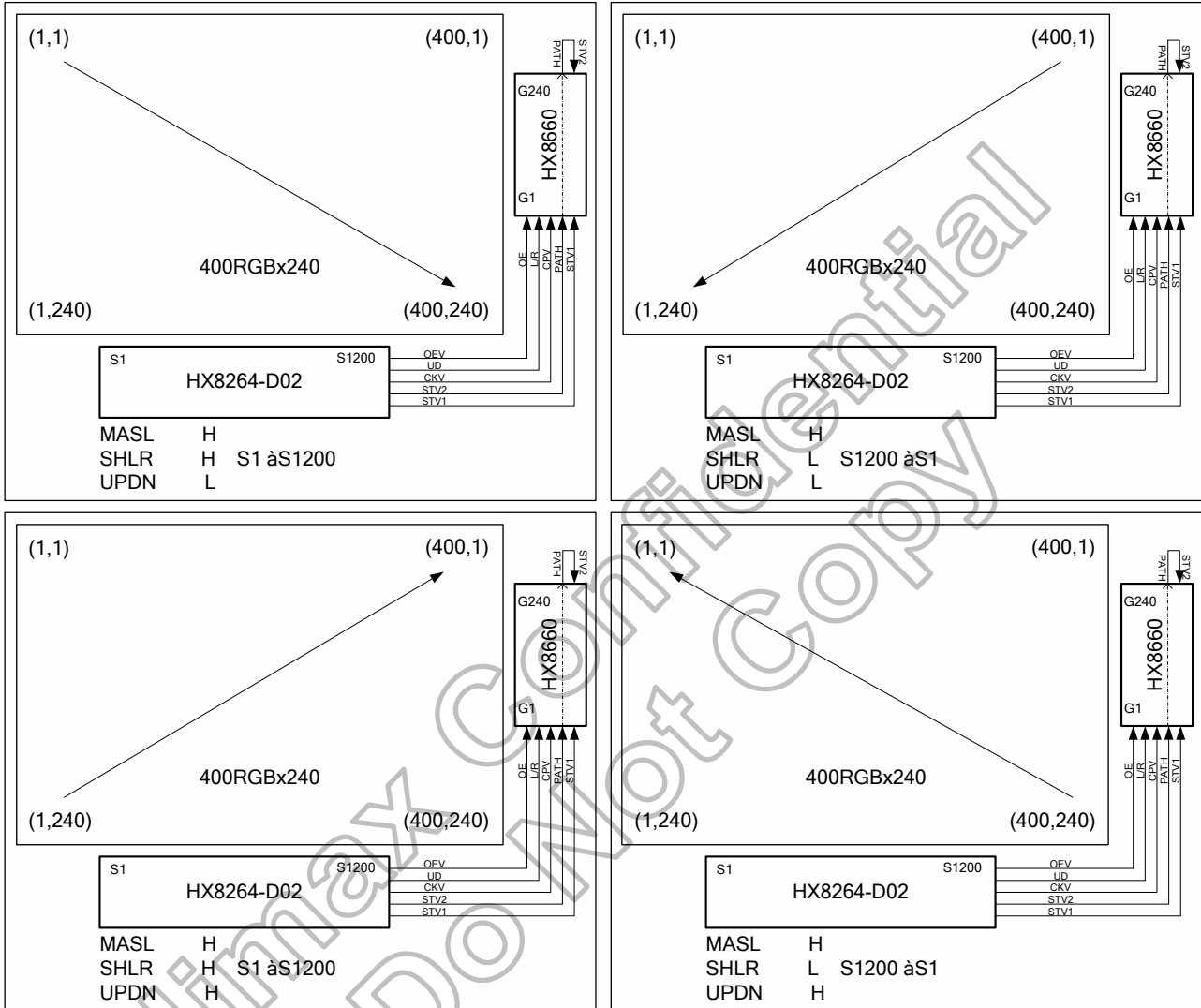

Figure 3. 3 HX8264-D02 Single Chip 400(RGB) x 240 Application Block Diagram-2

3.2.2 Two chip cascade application

a. 800(RGB) x 480 (Gate driver on left side)

RES [1:0]=00
DBGATE=0

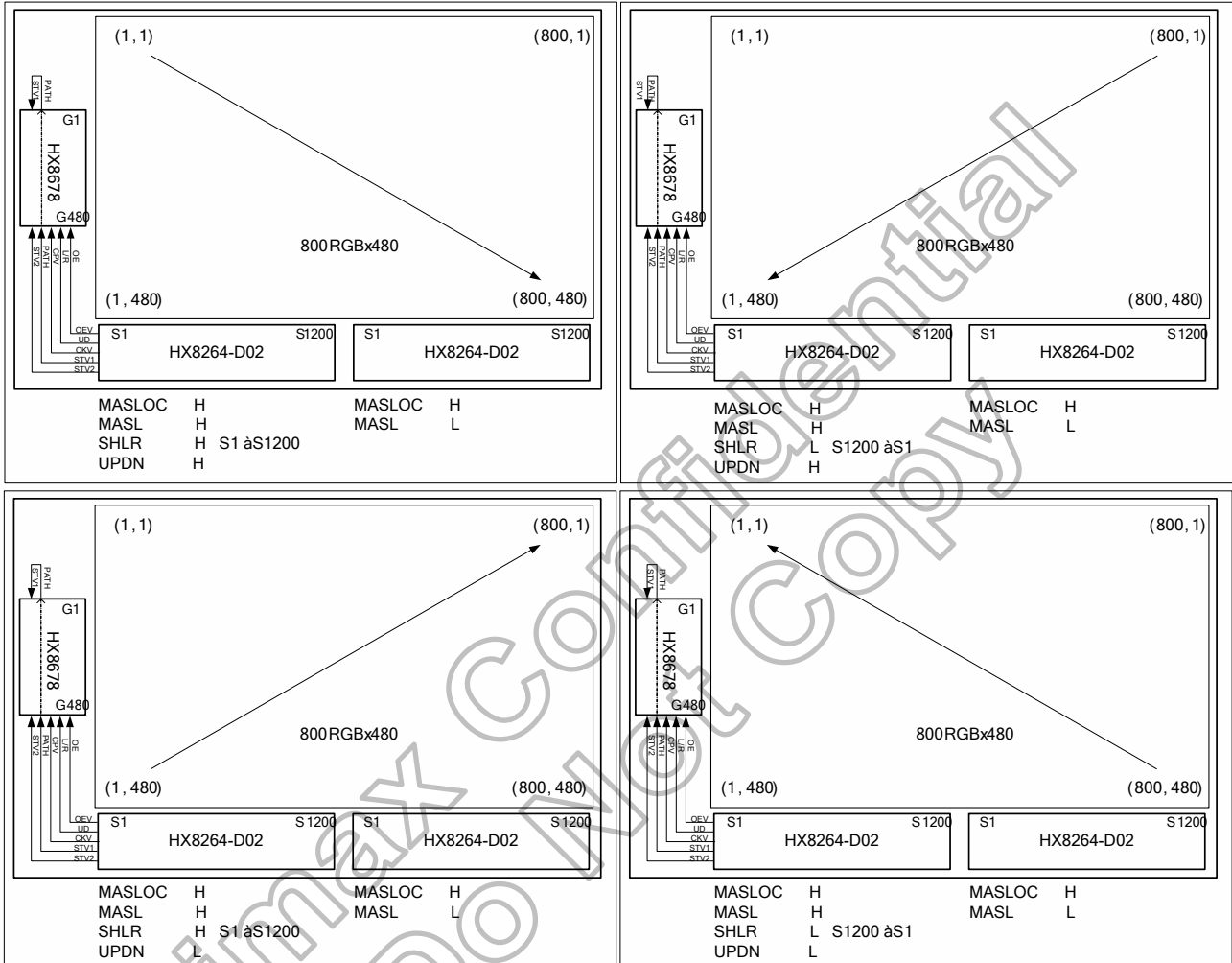

Figure 3. 4 HX8264-D02 Two Chip Cascade 800(RGB) x 480 Application Block Diagram-1

b. 800(RGB) x 480 (Gate driver on right side)

RES [1:0]=00
DBGATE=0

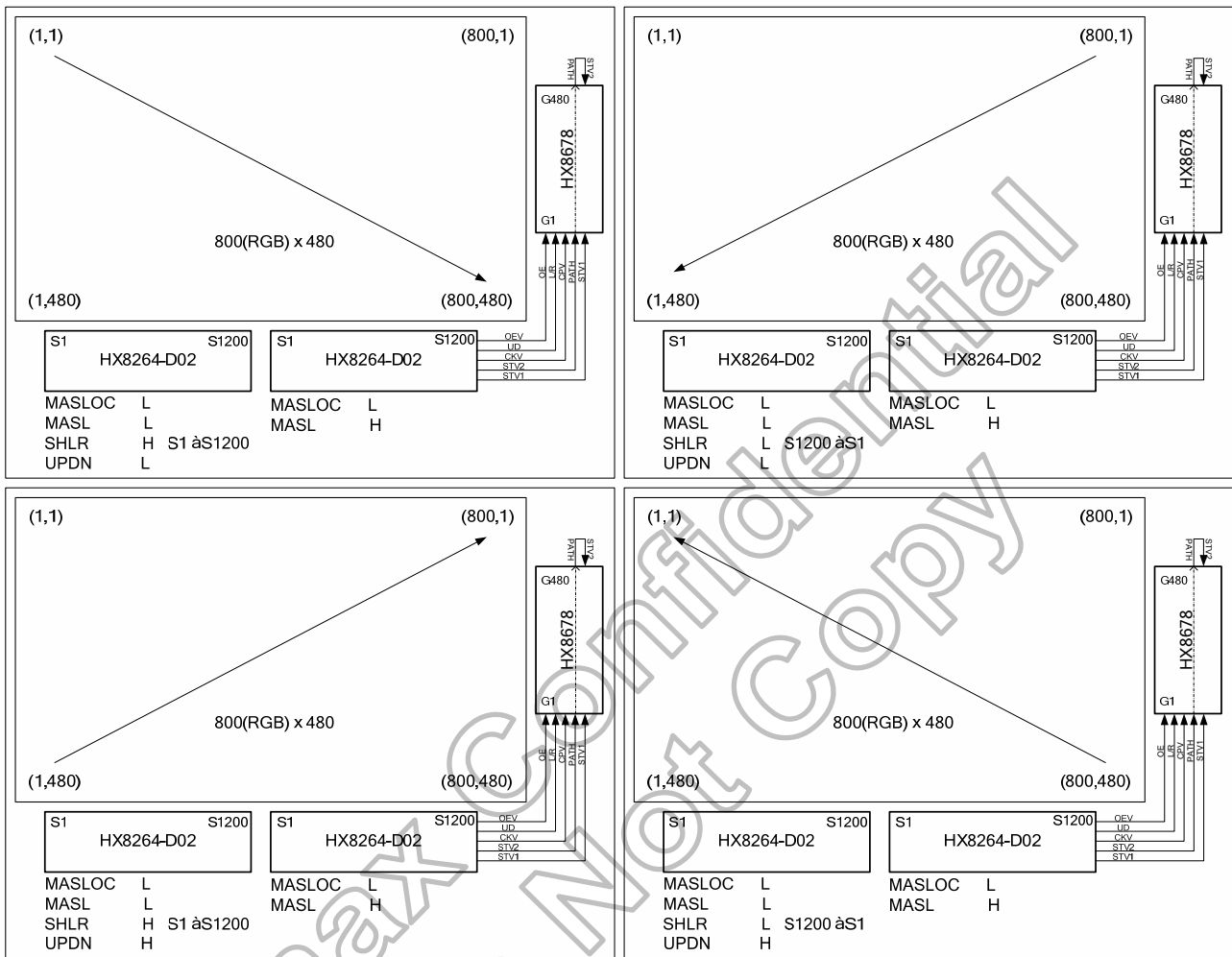

Figure 3. 5 HX8264-D02 Two Chip Cascade 800(RGB) x 480 Application Block Diagram-2

c. 800(RGB) x 600 (Gate driver on left side)

RES [1:0]=01
DBGATE=0

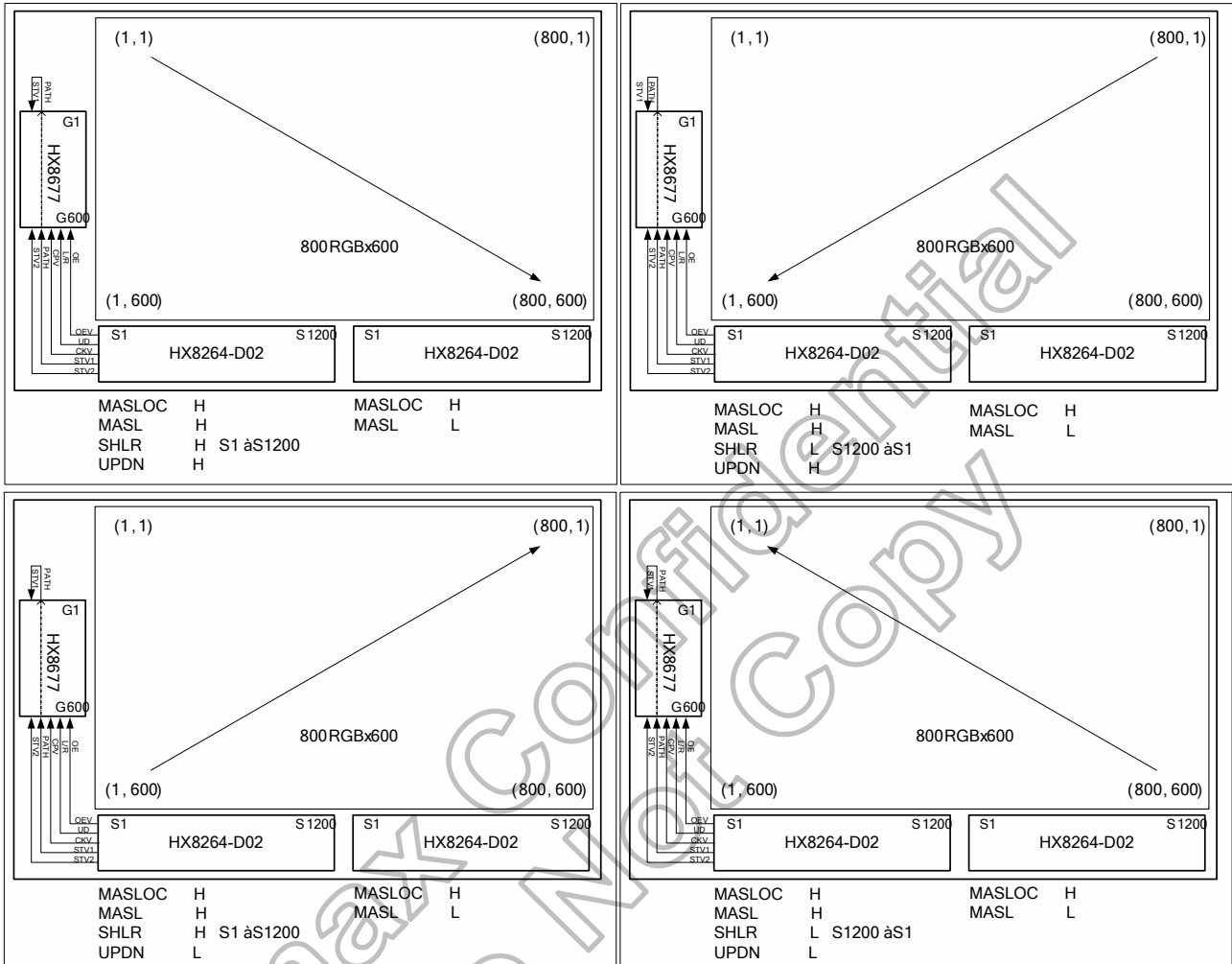

Figure 3. 6 HX8264-D02 Two Chip Cascade 800(RGB) x 600 Application Block Diagram-1

d. 800(RGB) x 600 (Gate driver on right side)

RES [1:0]=01
DBGATE=0

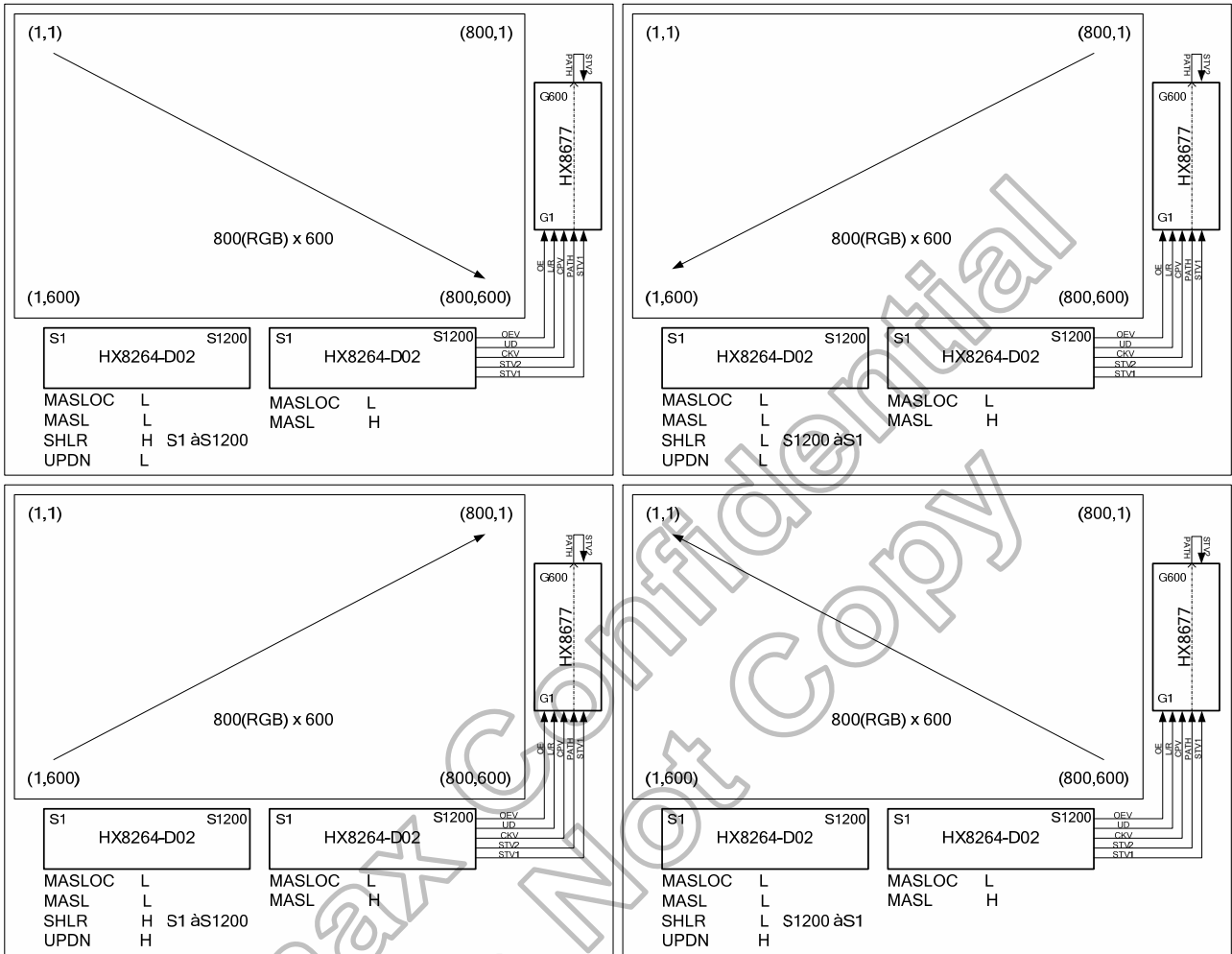

Figure 3. 7 HX8264-D02 Two Chip Cascade 800(RGB) x 600 Application Block Diagram-2

e. 640(RGB) x 480 (Gate driver on left side)

RES [1:0]=10 (Master and slave IC must be setup)

DBGATE=0

Channel 481~720 is disable

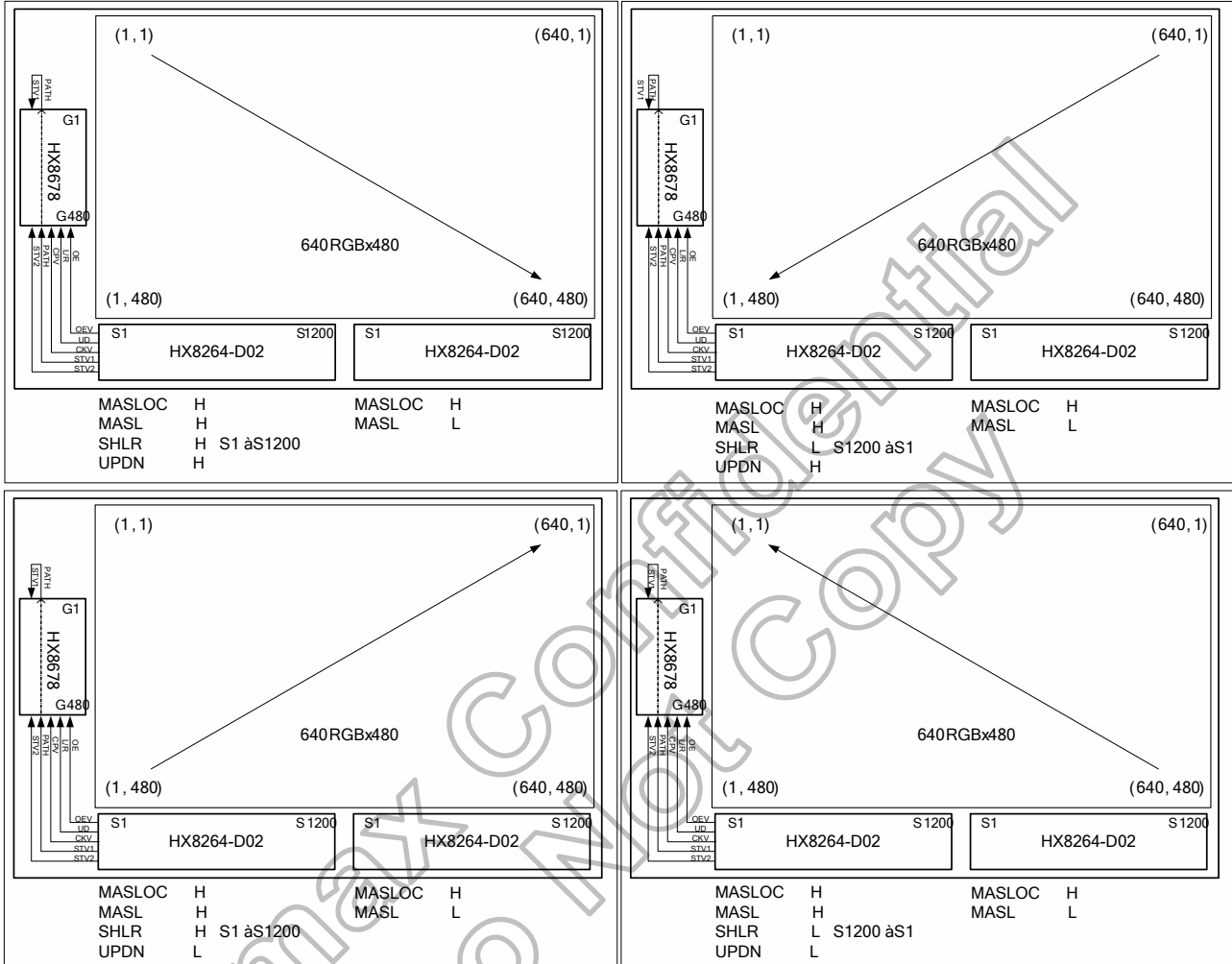

Figure 3. 8 HX8264-D02 Two Chip Cascade 640(RGB) x 480 Application Block Diagram-1

f. 640(RGB) x 480 (Gate driver on right side)

RES [1:0]=10 (Master and slave IC must be setup)

DBGATE=0

Channel 481~720 is disable

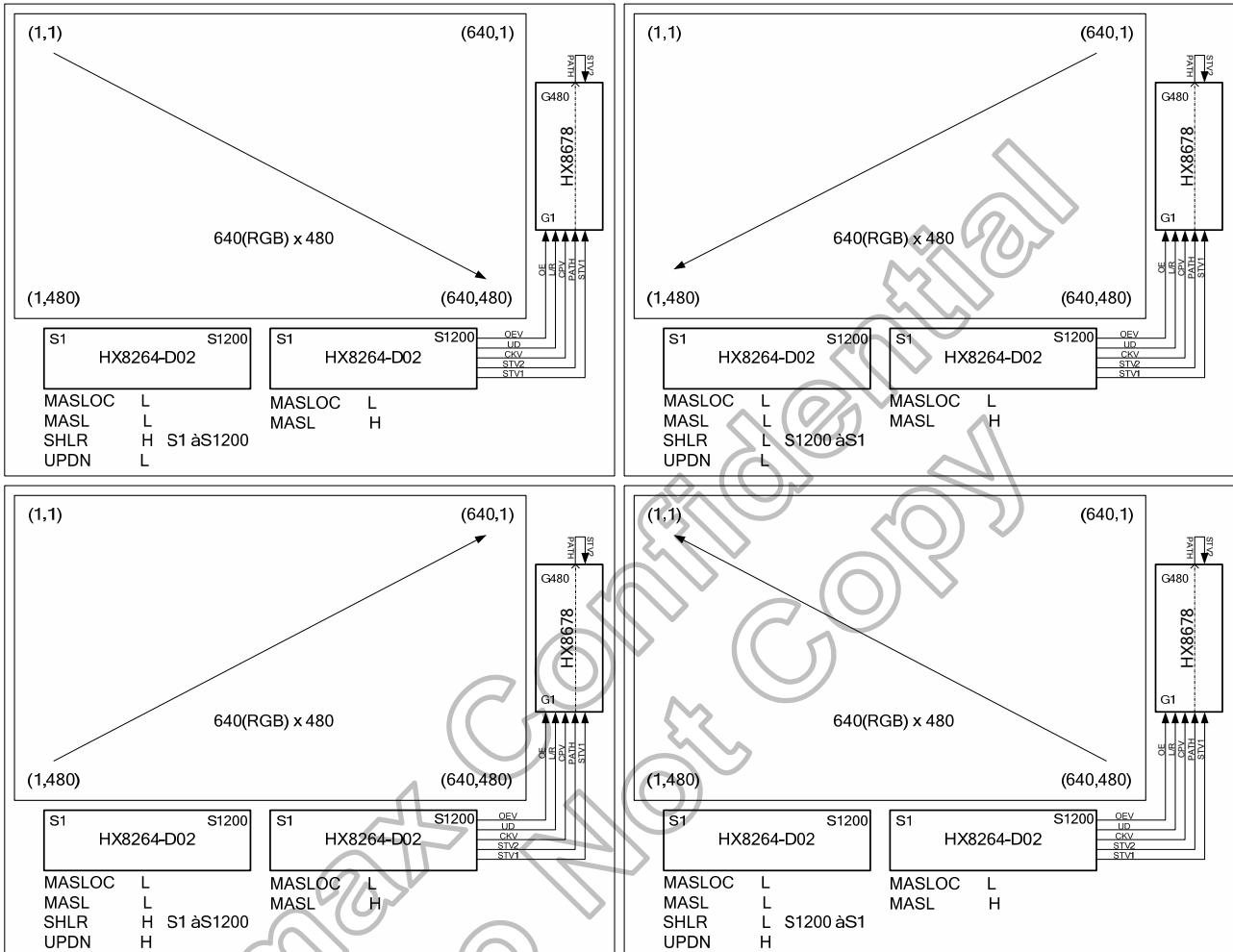

Figure 3. 9 HX8264-D02 Two Chip Cascade 640(RGB) x 480 Application Block Diagram-2

3.2.3 Dual gate application

a. 800(RGB) x 480 (Gate driver on left side)

RES [1:0]=00
CAS=0
DBGATE=1

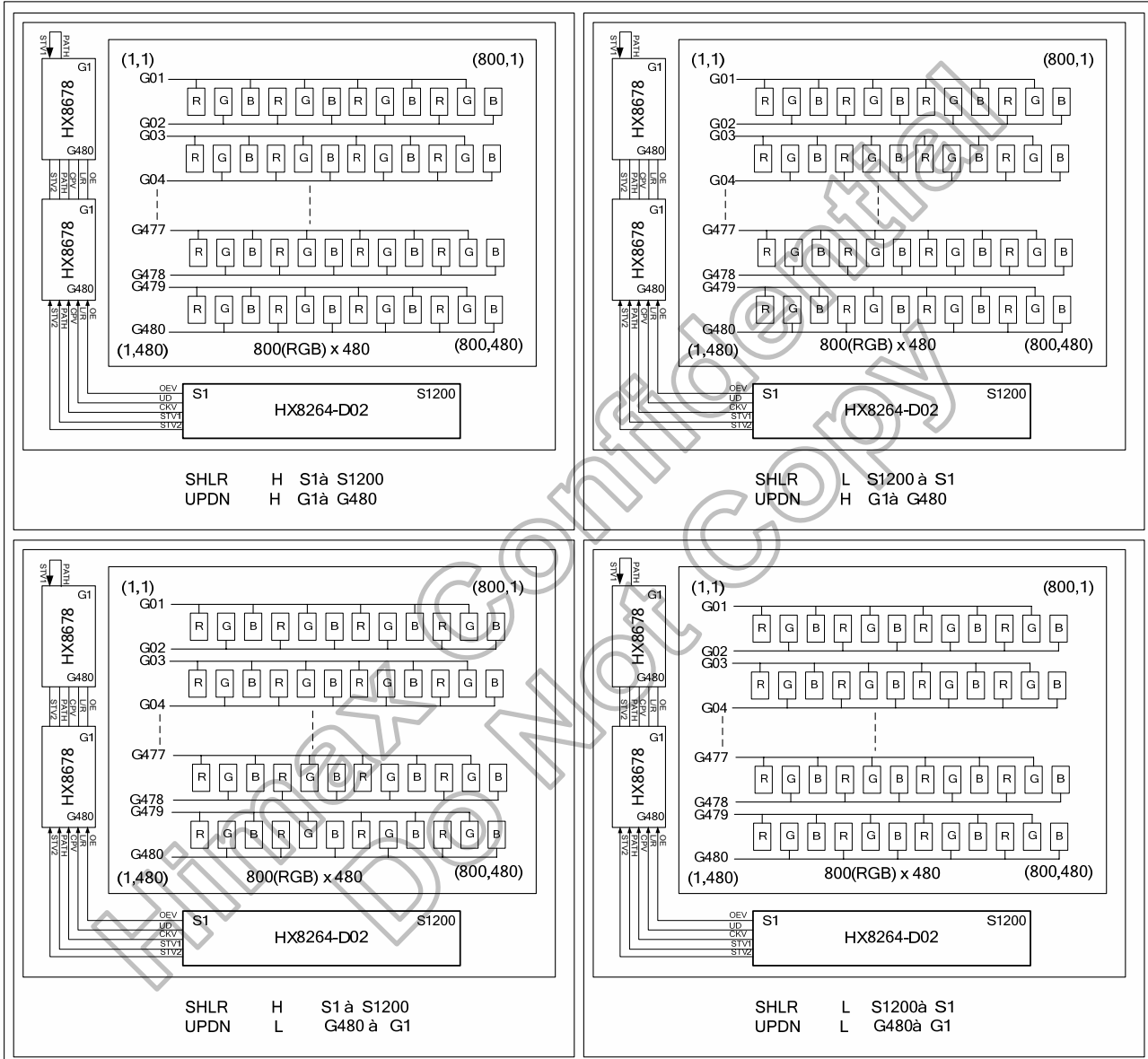

Figure 3. 10 HX8264-D02 Dual Gate 800(RGB) x 480 Application Block Diagram-1

b. 800(RGB) x 480 (Gate driver on right side)

RES [1:0]=00
CAS=0
DBGATE=1

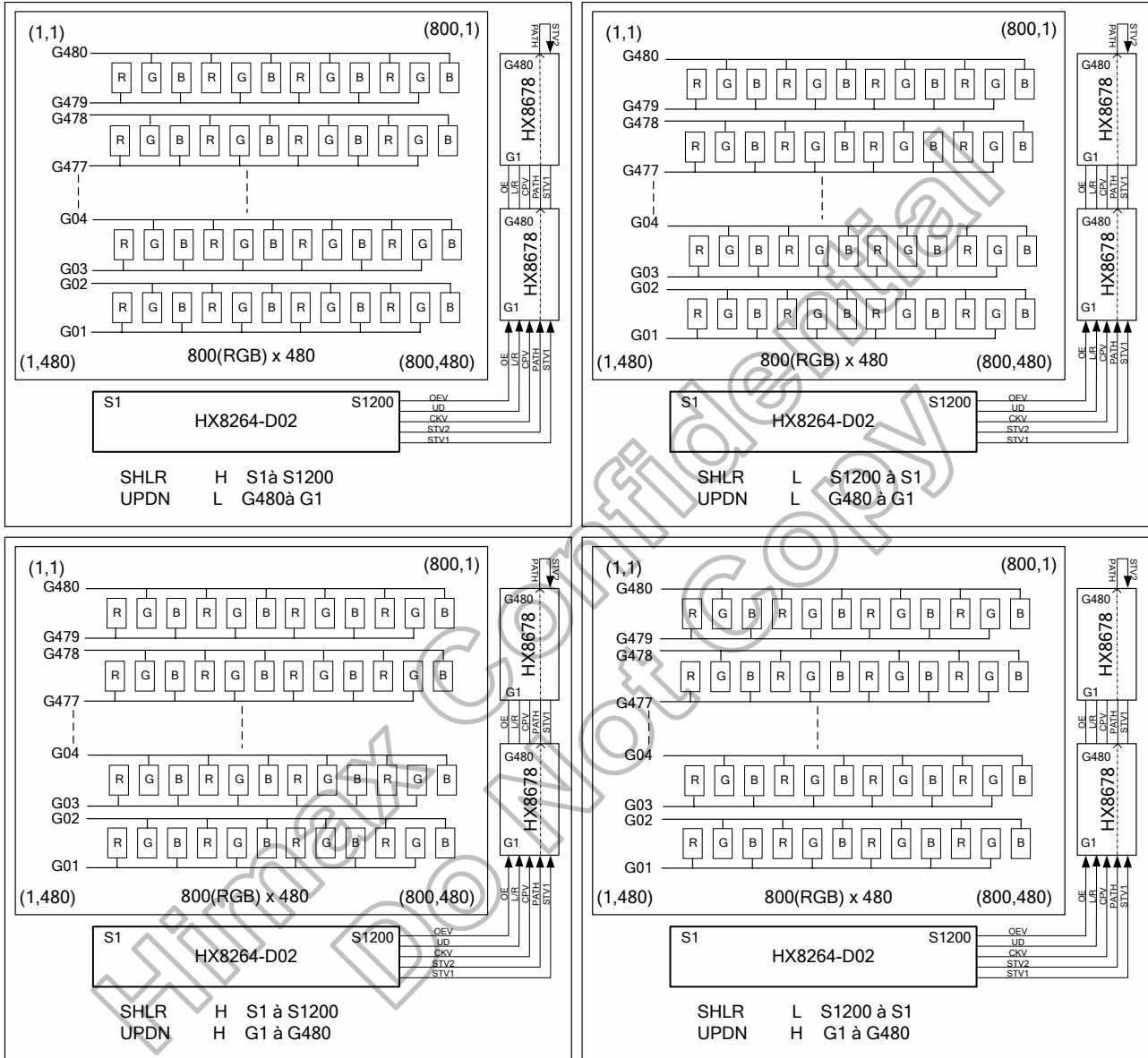

Figure 3. 11 HX8264-D02 Dual Gate 800(RGB) x 480 Application Block Diagram-2

c. 800(RGB) x 600 (Gate driver on left side)

RES [1:0]=01
CAS=0
DBGATE=1

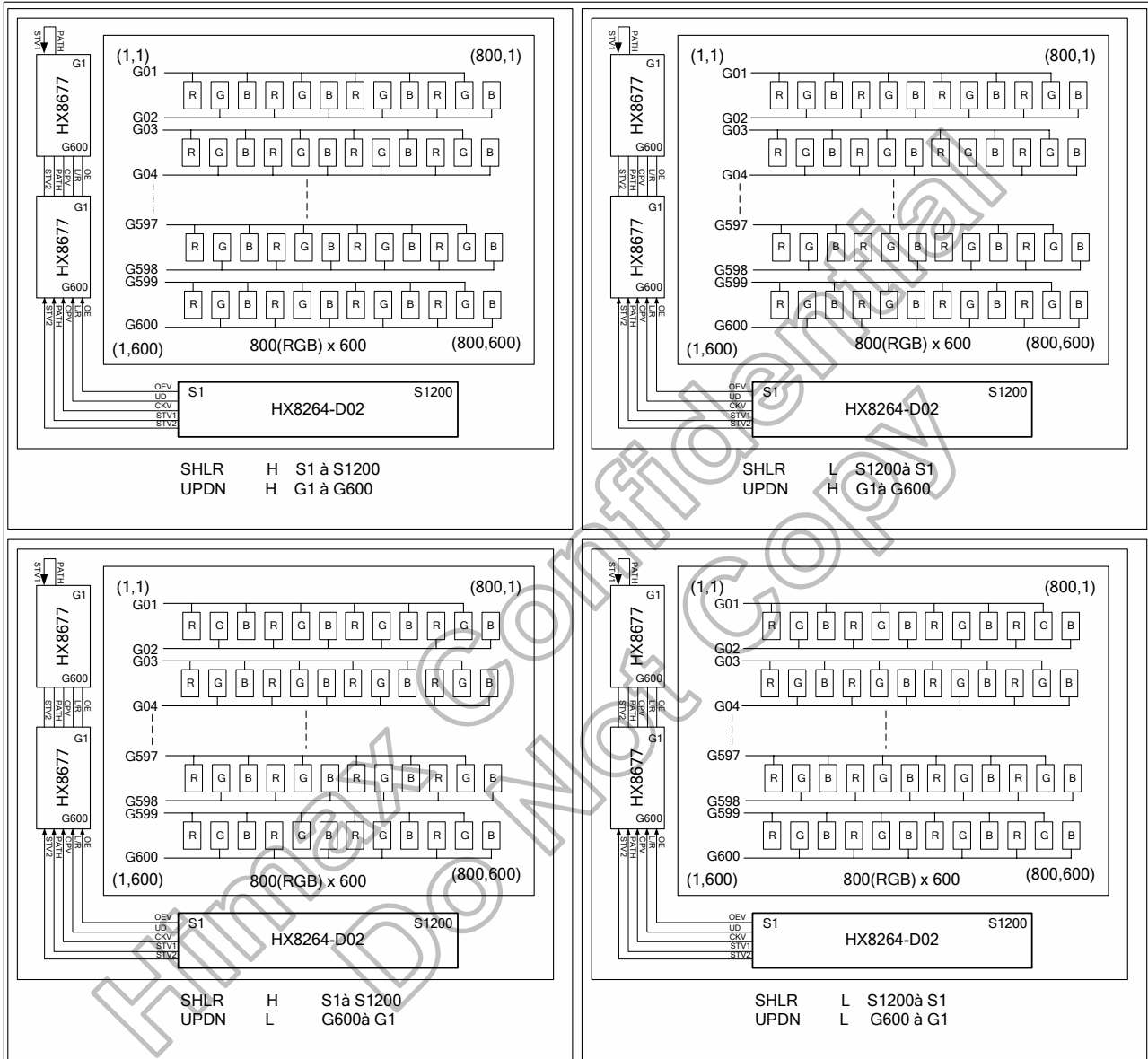

Figure 3. 12 HX8264-D02 Dual Gate 800(RGB) x 600 Application Block Diagram-1

d. 800(RGB) x 600 (Gate driver on right side)

RES [1:0]=01
CAS=0
DBGATE=1

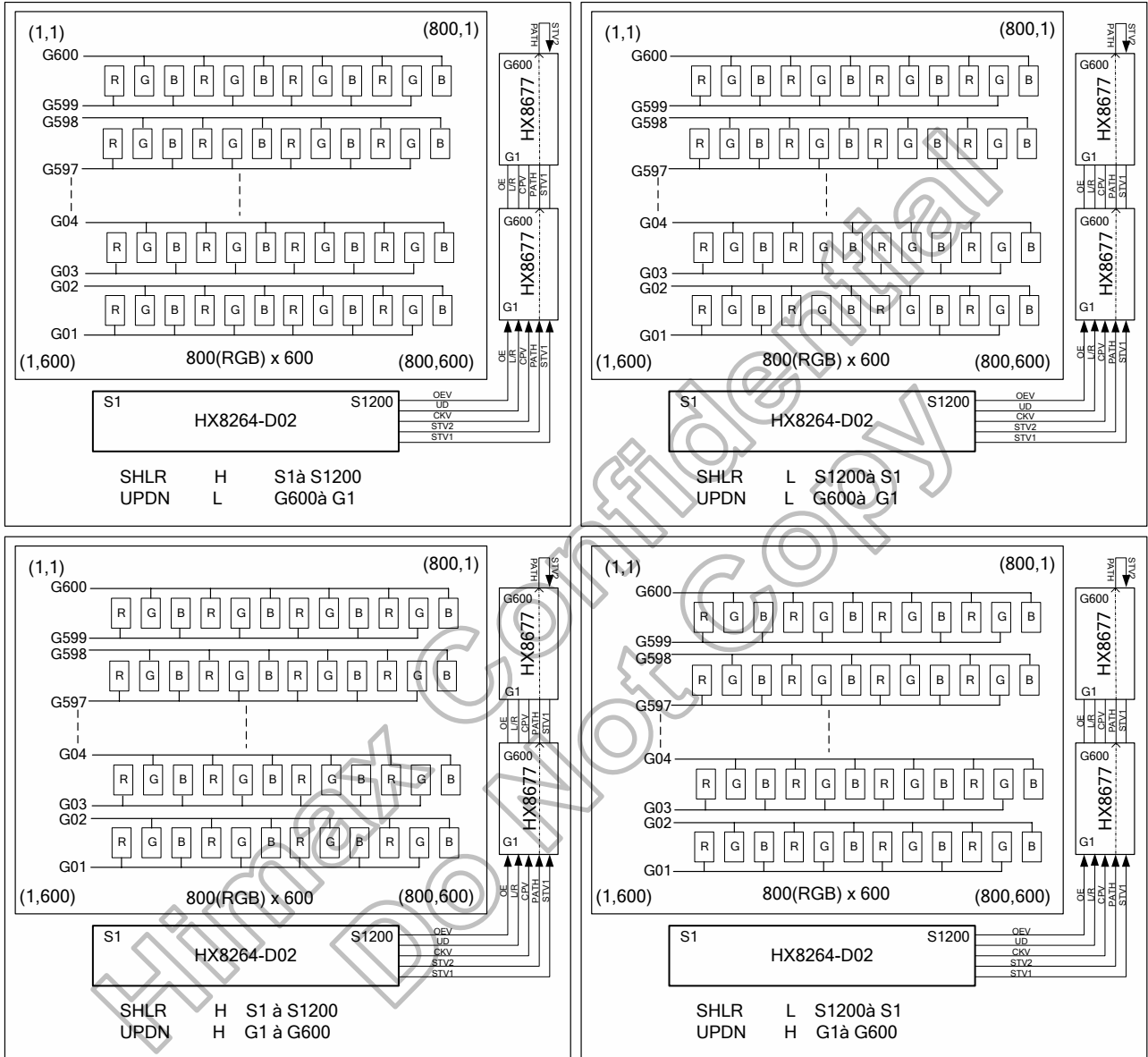

Figure 3. 13 HX8264-D02 Dual Gate 800(RGB) x 600 Application Block Diagram-2

e. 640(RGB) x 480 (Gate driver on left side)

RES [1:0]=10
 CAS=0
 DBGATE=1
 Channel 481~720 is disable

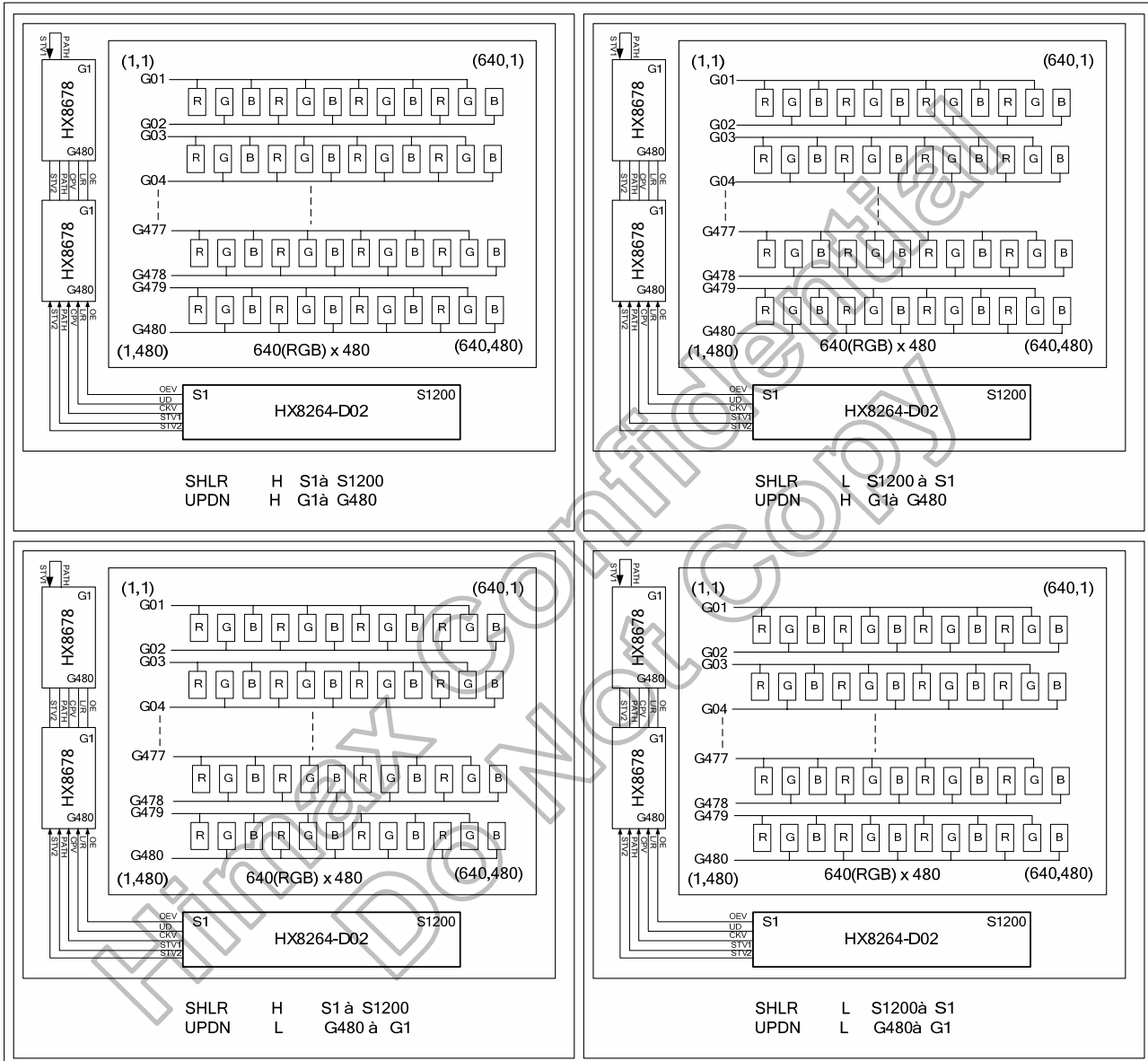

Figure 3. 14 HX8264-D02 Dual Gate 640(RGB) x 480 Application Block Diagram-1

f. 640(RGB) x 480 (Gate driver on right side)

RES [1:0]=10
 CAS=0
 DBGATE=1
 Channel 481~720 is disable

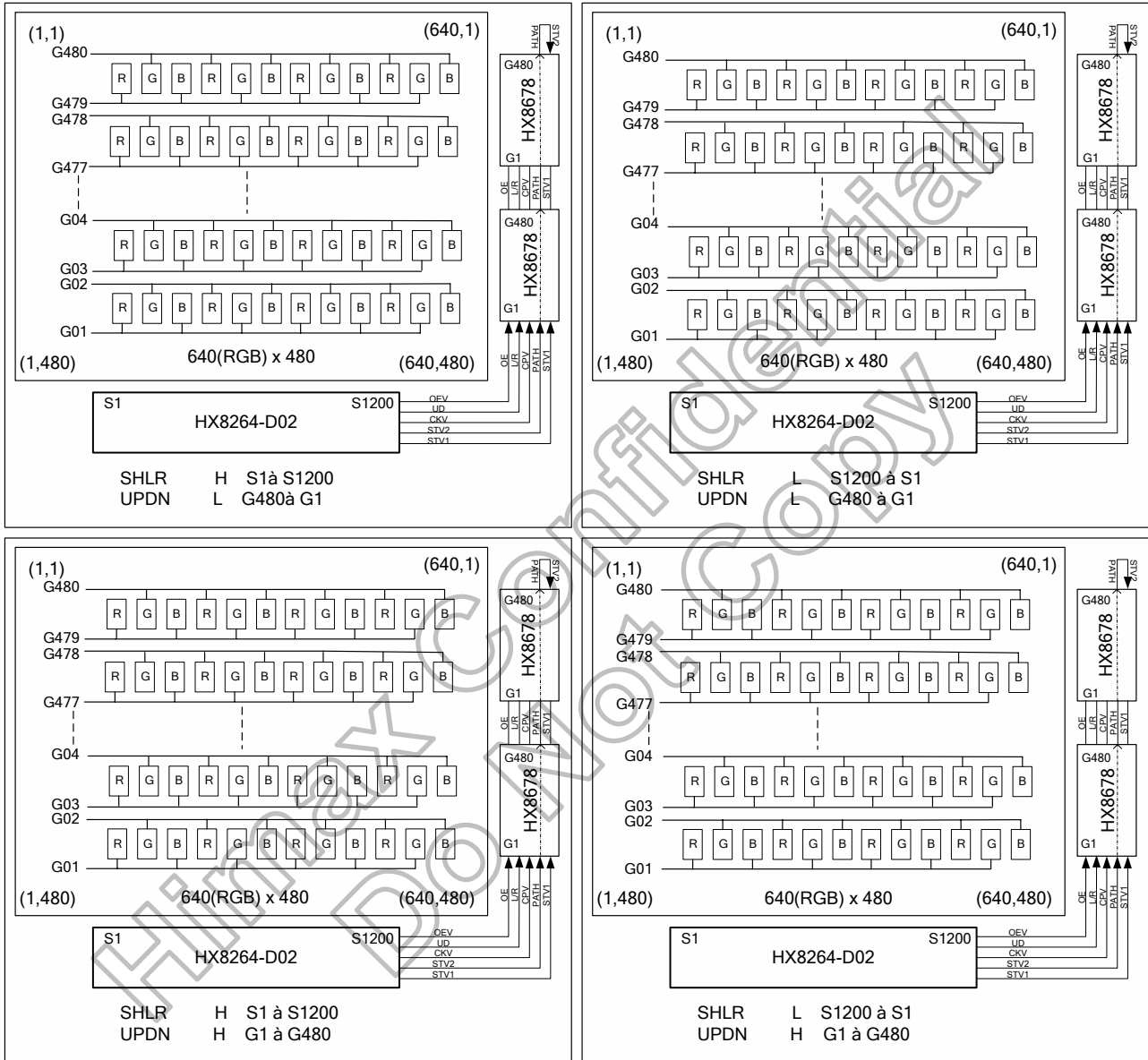

Figure 3. 15 HX8264-D02 Dual Gate 640(RGB) x 480 Application Block Diagram-2

4. Pin Description

HX8264-D02 pin description

Pin name	I/O	Description
D07~D00 D17~D10 D27~D20	I	Parallel data input. For TTL 24-bit parallel RGB image data input. D[07:00]=R[7:0] data; D[17:10]=G[7:0] data; D[27:20]=B[7:0] data. For 18-bit RGB interface, connect two LSB bits of all the R/G/B data buses to VSS.
CLKIN	I	Clock for input data. Data latched at rising/falling edge of this signal. Default falling edge. Normally pull low.
HSD	I	Horizontal sync input. Negative polarity. Normally pull high.
VSD	I	Vertical sync input. Negative polarity. Normally pull high.
DEN	I	Data input enable. Active high to enable the data input bus under "DE Mode ". Normally pull low.
MODE	I	DE/SYNC mode select. Normally pull high. MODE="1": DE mode. (Default) MODE="0": HSD/VSD mode.
REV	I	Data inverted control. Normally pull low REV="1": Data inverted for normally black LCD REV="0": Data not inverted for normally white LCD. (Default)
RES[1:0]	I	Display resolution selection. Normally pull low RES[1:0]="00": For 800(RGB)*480 display resolution. (Default) RES[1:0]="01": For 800(RGB)*600 display resolution. RES[1:0]="10": For 640(RGB)*480 display resolution. RES[1:0]="11": For 400(RGB)*240 display resolution. Note: When RES[1:0]="10", channel 481~720 is disable
SCEN	I	Serial Interface chip enable signal. Normally pull high SCEN="0": The chip is selected (accessible) SCEN="1": The chip is not selected (inaccessible) (Default) Note: Fix to the VDD level if no used
SCL/DBC3[0]	I	Multi function I/O pin. Normally pull high When DBC3="1", this pin is SCL function (Default) When DBC3="0", this pin is DBCM[0]function Note: Fix to the VDD level if no used
SDA/DBC3[1]	I/O	Multi function I/O pin. Normally pull high When DBC3="1", this pin is SDA function (Default) When DBC3="0", this pin is DBCM[1] function Note: Fix to the VDD level if no used
DBC3	I	CABC control by hardware or SPI selection. Normally pull high DBC3="0": CABC control by hardware DBC3="1": CABC control by SPI software (Default)
DITHB	I	Dithering function enable control. Normally pull high. DITHB="1": Disable internal dithering function. (Default) DITHB="0": Enable internal dithering function.
CLKPOL	I	Input clock edge selection. Normally pull low. CLKPOL="1": Latch data at CLKIN rising edge. CLKPOL="0": Latch data at CLKIN falling edge. (Default)

CFSEL	I	Color filter type selection. Normally pull low. CFSEL="0": Stripe mode. (Default) CFSEL="1": Delta mode.
BLKEN	O	Backlight enable control signal for external controller. BLKEN="1": Logical control signal to turn on external backlight controller. BLKEN="0": Turn off external backlight controller. Note: Refer to the power on/off sequence for the detail information.
CABC_EN	I	CABC Function Enable Control. Normally pull low CABC_EN="0": CABC_PWM pin is used to be backlight control signal for external backlight controller. The same as BLKEN pin (Default) CABC_EN="1": CABC_PWM pin will refer the gray scale content of display image to output a PWM pulse to backlight driver
CABC_PWM	O	CABC PWM output
DBGATE	I	Dual gate function enables control. Normally pull low. DBGATE="1": Enable Dual Gate Function. DBGATE="0": Disable Dual Gate Function. (Default) Note: Cascade function will be disabled under "dual gate" mode!
V1 ~ V14	I	Gamma correction reference voltage. These input voltage must be offered by user. $VSSA < V14 < V13 < V12 < V11 < V10 < V9 < V8 ; V7 < V6 < V5 < V4 < V3 < V2 < V1 < VDDA$. Please make sure $VDDA-1 > V1$.
VSET	I	Gamma voltage input selection. Normally pull low. VSET="0": 10 gamma voltage input, V2, V6, V9, V13 is disable. (Default) VSET="1": V1~V14 gamma voltage input.
RSTB	I	Global reset pin. Active low to enter Reset State. Suggest to connecting with an RC reset circuit for stability. Normally pull high.
STBYB	I	Standby mode. Normally pulled high. STBYB="1": Normally operation (Default) STBYB="0": Timing controller, source driver will turn off ,all output are High-Z.
MASL	I	Master and slave mode selection. Normally pulled high. MASL="1": For master mode. (Default) MASL="0": For slave mode. Only the master chip will issue the gate and cascade control signal.
MASLOC	I	Master location definition pin. Normally pull low. MASLOC="0": Master locate on right side (Panel top view).(Default) MASLOC="1": Master locate on left side (Panel top view).
SHLR	I	Source Right or Left sequence control. Normally pulled high. SHLR="0": Shift left: last data=S1 ← S2 ← S3..... ← S1200=first data. SHLR="1": Shift right: first data=S1 → S2 → S3..... → S1200=last data.
UPDN	I	Gate up or down scan control. Normally pulled low. UPDN="0": STV2 output vertical start pulse and UD pin output logical "0" to gate driver. (Default) UPDN="1": STV1 output vertical start pulse and UD pin output logical "1" to gate driver.

BIST	I	Normal operation/BIST pattern select. Normally pull low. BIST="1": BIST (DCLK input is not needed.) BIST="0": Normal operation. (Default) When BIST="1", CABC function will turn off, CABC_PWM keep high
CAS	I	Cascade function select. Normally pull high. CAS="1": Enable cascade function. (Default) CAS="0": Disable cascade function.
DATR[17:0]	I/O	Multi function I/O pin. Refer to the cascade DAT pin mapping table for the detail.
DCLKR	I/O	Master and slave cascade control signal.
DIOR	I/O	Master and slave cascade control signal.
POLR	I/O	Master and slave cascade control signal.
LDR	I/O	Master and slave cascade control signal.
SYNCR	I/O	Master and slave cascade control signal.
DATL[17:0]	I/O	Multi function I/O pin. Refer to the cascade DAT pin mapping table for the detail.
DCLKL	I/O	Master and slave cascade control signal.
DIOL	I/O	Master and slave cascade control signal.
POLL	I/O	Master and slave cascade control signal.
LDL	I/O	Master and slave cascade control signal.
SYNCL	I/O	Master and slave cascade control signal.
VDDA	PI	Power supply for analog circuits.
VSSA	PI	Ground pins for analog circuits.
VDD	PI	Power supply for digital circuits.
VSS	PI	Ground pins for digital circuits.
SO1~SO1200	O	Source driver output signals. All outputs will be of unknown values under stand-by mode.
ALIGN	M	For assembly alignment.
COM1_B COM2_B	S	Internal link together between input side and output side.
COM1_T COM2_T	S	Internal link together between input side and output side.
TP9~0	T	Test pin for Himax only. Float these pins for normal operation.
TESTG	T	Test pin for Himax only. Float this pin for normal operation.
SHIELDING	SH	IC shielding pads. Those pins are internally connected to the VSSA. DO NOT connect to any WOA on the panel.
DASHD	SH	Data bus shielding pad. Those pins are internally connected to the VSS. Recommend to add shielding lines on the FPC to reduce EMI.

Note: I: Input, O: Output, P: Power, D: Dummy, S: Shorted line, M: Mark, PI: Power input, PO: Power output, T: Testing, SH: Shielding, I/O: Input/Output, PS: Power Setting, C: Capacitor Pin.

HX8264-D02 passes line description:

Pass Line No:	Pin Name	
1	COM1_B	COM1_T
2	COM2_B	COM2_T

Table 4. 1 HX8264-D02 Pass Line Description

Value of wiring resistance to each pin:

The recommended wiring resistance values are shown below. The wiring resistance values affect.

The current capacity of the power supply, so be sure to design using values that do not exceed those recommended.

Pin Name	Wiring resistance value(Ω)
VDD	< 25
VDDA	< 5
VSS	< 25
VSSA	< 5
V1~V14	< 20
D00~D07	< 200
D10~D17	< 200
D20~D27	< 200
DEN	< 200
MODE	< 1000
RES[1:0]	< 1000
DITHB	< 1000
CLKPOL	< 1000
BLKEN	< 1000
CFSEL	< 1000
DBGATE	< 1000
RSTB	< 1000
MASL	< 1000
MASLOC	< 1000
SHLR	< 1000
UPDN	< 1000
BIST	< 1000
CAS	< 1000
SCEN	< 200
SCL/DBC[M][0]	< 200
SDA/DBC[M][1]	< 200
DBC3	<1000
DATR[17:0]	< 200 & 20 pf
DCLKR	< 200 & 20 pf
DIOR	< 200 & 20 pf
POLR	< 200 & 20 pf
LDR	< 200 & 20 pf
SYNCR	< 200 & 20 pf
DATRL[17:0]	< 200 & 20 pf
DCLKL	< 200 & 20 pf
DIOL	< 200 & 20 pf
POLL	< 200 & 20 pf
LDL	< 200 & 20 pf
CASCADE V1~V14	< 50
CLKIN	< 50
HSD	< 200
VSD	< 200

Table 4. 2 The Recommended Wiring Resistance Values

5. Operation Description

5.1 Relationship between input data and output channels

- **DBGATE="0", CFSEL="0", stripe mode**

(1) SHLR="1", right shift

Output	Out1	Out2	Out3	Out1198	Out1199	Out1200
Order	First Data			→	→	→	Last Data		
Odd Line	D07~D00	D17~D10	D27~D20	D07~D00	D17~D10	D27~D20
Even Line	D07~D00	D17~D10	D27~D20	D07~D00	D17~D10	D27~D20

(2) SHLR="0", left shift

Output	Out1	Out2	Out3	Out1198	Out1199	Out1200
Order	Last Data			←	←	←	First Data		
Odd Line	D07~D00	D17~D10	D27~D20	D07~D00	D17~D10	D27~D20
Even Line	D07~D00	D17~D10	D27~D20	D07~D00	D17~D10	D27~D20

- **DBGATE="0", CFSEL="1", delta mode**

(1) SHLR="1", right shift

Output	Out1	Out2	Out3	Out1198	Out1199	Out1200
Order	First Data			→	→	→	Last Data		
Odd Line	D07~D00	D17~D10	D27~D20	D07~D00	D17~D10	D27~D20
Even Line	D17~D10	D27~D20	D07~D00	D17~D10	D27~D20	D07~D00

(2) SHLR="0", left shift

Output	Out1	Out2	Out3	Out1198	Out1199	Out1200
Order	Last Data			←	←	←	First Data		
Odd Line	D07~D00	D17~D10	D27~D20	D07~D00	D17~D10	D27~D20
Even Line	D17~D10	D27~D20	D07~D00	D17~D10	D27~D20	D07~D00

● **DBGATE="1", CFSEL="0", stripe mode**

(1) SHLR="1", right shift

Output	Out1	Out2	Out3	Out1198	Out1199	Out1200
Order	First Data			→	→	→	Last Data		
Odd Line /Gn	D07~D00	D27~D20	D17~D10	D07~D00	D27~D20	D17~D10
Odd Line /Gn+1	D17~D10	D07~D00	D27~D20	D17~D10	D07~D00	D27~D20
Even Line /Gn	D07~D00	D27~D20	D17~D10	D07~D00	D27~D20	D17~D10
Even Line /Gn+1	D17~D10	D07~D00	D27~D20	D17~D10	D07~D00	D27~D20

(2) SHLR="0", left shift

Output	Out1	Out2	Out3	Out1198	Out1199	Out1200
Order	Last Data			←	←	←	First Data		
Odd Line /Gn	D07~D00	D27~D20	D17~D10	D07~D00	D27~D20	D17~D10
Odd Line /Gn+1	D17~D10	D07~D00	D27~D20	D17~D10	D07~D00	D27~D20
Even Line /Gn	D07~D00	D27~D20	D17~D10	D07~D00	D27~D20	D17~D10
Even Line /Gn+1	D17~D10	D07~D00	D27~D20	D17~D10	D07~D00	D27~D20

● **DBGATE="1", CFSEL="1", delta mode**

(1) SHLR="1", right shift

Output	Out1	Out2	Out3	Out1198	Out1199	Out1200
Order	First Data			→	→	→	Last Data		
Odd Line /Gn	D07~D00	D27~D20	D17~D10	D07~D00	D27~D20	D17~D10
Odd Line /Gn+1	D17~D10	D07~D00	D27~D20	D17~D10	D07~D00	D27~D20
Even Line /Gn	D17~D10	D07~D00	D27~D20	D17~D10	D07~D00	D27~D20
Even Line /Gn+1	D27~D20	D17~D10	D07~D00	D27~D20	D17~D10	D07~D00

(2) SHLR="0", left shift

Output	Out1	Out2	Out3	Out1198	Out1199	Out1200
Order	Last Data			←	←	←	First Data		
Odd Line /Gn	D07~D00	D27~D20	D17~D10	D07~D00	D27~D20	D17~D10
Odd Line /Gn+1	D17~D10	D07~D00	D27~D20	D17~D10	D07~D00	D27~D20
Even Line /Gn	D17~D10	D07~D00	D27~D20	D17~D10	D07~D00	D27~D20
Even Line /Gn+1	D27~D20	D17~D10	D07~D00	D27~D20	D17~D10	D07~D00

5.2 HX8264-D02 configuration table

HX8264-D02 supports timing controllers for four resolutions. Since HX8264-D02 has 1200 channels, for example, two pieces of HX8264-D02 source drivers are cascaded and extended to 2400 channels of 800RGB. The configuration summary tables of the HX8264-D02 are illustrated as below two figures.

DATR[17:0]	DBGATE="0" MASL="1" MASLOC="0" CAS="1"	DBGATE="0" MASL="1" MASLOC="1" CAS="1"	DBGATE="0" MASL="0" MASLOC="0" CAS="1"	DBGATE="0" MASL="0" MASLOC="1" CAS="1"	DBGATE="1" MASL="1" MASLOC="X" CAS="0"	DBGATE="0" MASL="1" MASLOC="X" CAS="0" RES[1:0]="XX"
Description	Master mode. Master locates on panel right side.	Master mode. Master locates on panel left side.	Slave mode. Master locates on panel right side.	Slave mode. Master locates on panel left side.	Dual gate mode	Single source mode
DATR0	X	DAT0	DAT0	X	X	X
DATR1	X	DAT1	DAT1	X	X	X
DATR2	OEV	DAT2	DAT2	X	OEV	OEV
DATR3	X	DAT3	DAT3	X	X	X
DATR4	UD	DAT4	DAT4	X	UD	UD
DATR5	X	DAT5	DAT5	X	X	X
DATR6	CKV	DAT6	DAT6	X	CKV	CKV
DATR7	X	DAT7	DAT7	X	X	X
DATR8	STV1	DAT8	DAT8	X	STV1	STV1
DATR9	X	DAT9	DAT9	X	X	X
DATR10	STV2	DAT10	DAT10	X	STV2	STV2
DATR11	X	DAT11	DAT11	X	X	X
DATR12	STV1	DAT12	DAT12	X	STV1	STV1
DATR13	X	DAT13	DAT13	X	X	X
DATR14	X	DAT14	DAT14	X	X	X
DATR15	X	DAT15	DAT15	X	X	X
DATR16	STBN	DAT16	DAT16	X	STBN	STBN
DATR17	X	DAT17	DAT17	X	X	X
DCLKR	X	DCLK	DCLK	X	X	X
DIOR	X	DIO	DIO	X	X	X
LDR	X	LD	LD	X	X	X
SYNCR	X	SYNC	SYNC	X	X	X

Table 5. 1 HX8264-D02 DATR[17:0] Pin Mapping Table







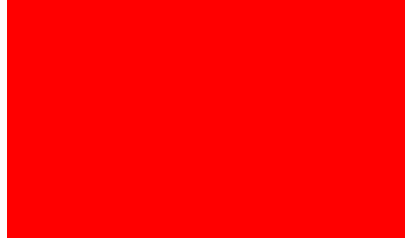

DATL[17:0]	DBGATE="0" MASL="1" MASLOC="0" CAS="1"	DBGATE="0" MASL="1" MASLOC="1" CAS="1"	DBGATE="0" MASL="0" MASLOC="0" CAS="1"	DBGATE="0" MASL="0" MASLOC="1" CAS="1"	DBGATE="1" MASL="1" MASLOC="X" CAS="0"	DBGATE="0" MASL="1" MASLOC="X" CAS="0" RES[1:0]="XX"
Description	Master mode. Master locates on panel right side.	Master mode. Master locates on panel left side.	Slave mode. Master locates on panel right side.	Slave mode. Master locates on panel left side.	Dual gate mode	Single source mode
DATL0	DAT0	X	X	DAT0	X	X
DATL1	DAT1	X	X	DAT1	X	X
DATL2	DAT2	OEV	X	DAT2	OEV	OEV
DATL3	DAT3	X	X	DAT3	X	X
DATL4	DAT4	UD	X	DAT4	UD	UD
DATL5	DAT5	X	X	DAT5	X	X
DATL6	DAT6	CKV	X	DAT6	CKV	CKV
DATL7	DAT7	X	X	DAT7	X	X
DATL8	DAT8	STV1	X	DAT8	STV1	STV1
DATL9	DAT9	X	X	DAT9	X	X
DATL10	DAT10	STV2	X	DAT10	STV2	STV2
DATL11	DAT11	X	X	DAT11	X	X
DATL12	DAT12	STV1	X	DAT12	STV1	STV1
DATL13	DAT13	X	X	DAT13	X	X
DATL14	DAT14	X	X	DAT14	X	X
DATL15	DAT15	X	X	DAT15	X	X
DATL16	DAT16	STBN	X	DAT16	STBN	STBN
DATL17	DAT17	X	X	DAT17	X	X
DCLKL	DCLK	X	X	DCLK	X	X
DIOL	DIO	X	X	DIO	X	X
LDL	LD	X	X	LD	X	X
SYNCL	SYNC	X	X	SYNC	X	X

Table 5. 2 HX8264-D02 DATL[17:0] Pin Mapping Table

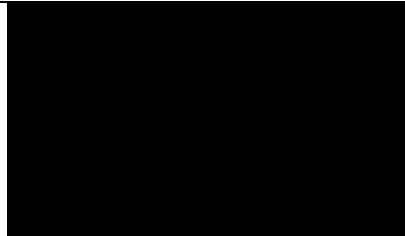
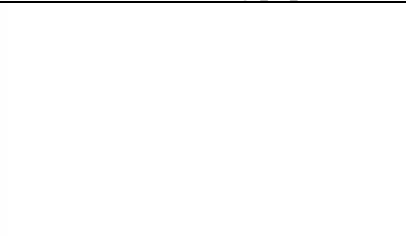
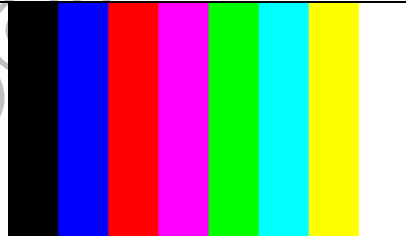
5.3 The BIST Pattern for Aging Mode Test

HX8264-D02 supports BIST pattern for aging mode test automatically. When external BIST pin set to “H” level, then HX8264-D02 will leave normal operation mode and starts to generate the BIST pattern to LCD panel without external clock signal. The CABC function will turn off and CABC_PWM output keep high level when BIST mode enable.

The BIST pattern is illustrated as below:

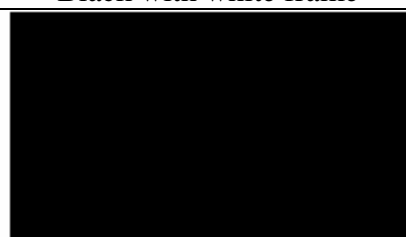
1 Red	2 Green	3 Blue
		
4 Black	5 White	6 Color Bar
		
7 Vertical 64 gray scale	8 Horizontal 64 gray scale	9 Gray with black block
		
10 Gray with black dot	11 Gray with black line	12 Black with white frame
		

6. Gamma Adjustment Function

6.1 Relationship between gamma correction and output voltage

HX8264-D02 supports 2 gamma curve for normally white or normally black LCD depend on REV function pin. The output voltage is determined by the 6-bit DAC input data, and the V1 ~ V14 gamma correction reference voltage inputs.

Input code	Normally white LCD REV = L	Normally black LCD REV = H
00H	00H	3FH
0AH	0AH	35H
35H	35H	0AH
3FH	3FH	00H

Gamma correction characteristic curve:

VSET=0, 10 gamma voltage input, V2, V6, V9, V13 is disable (Default)

VSET=1, 14 gamma voltage input.

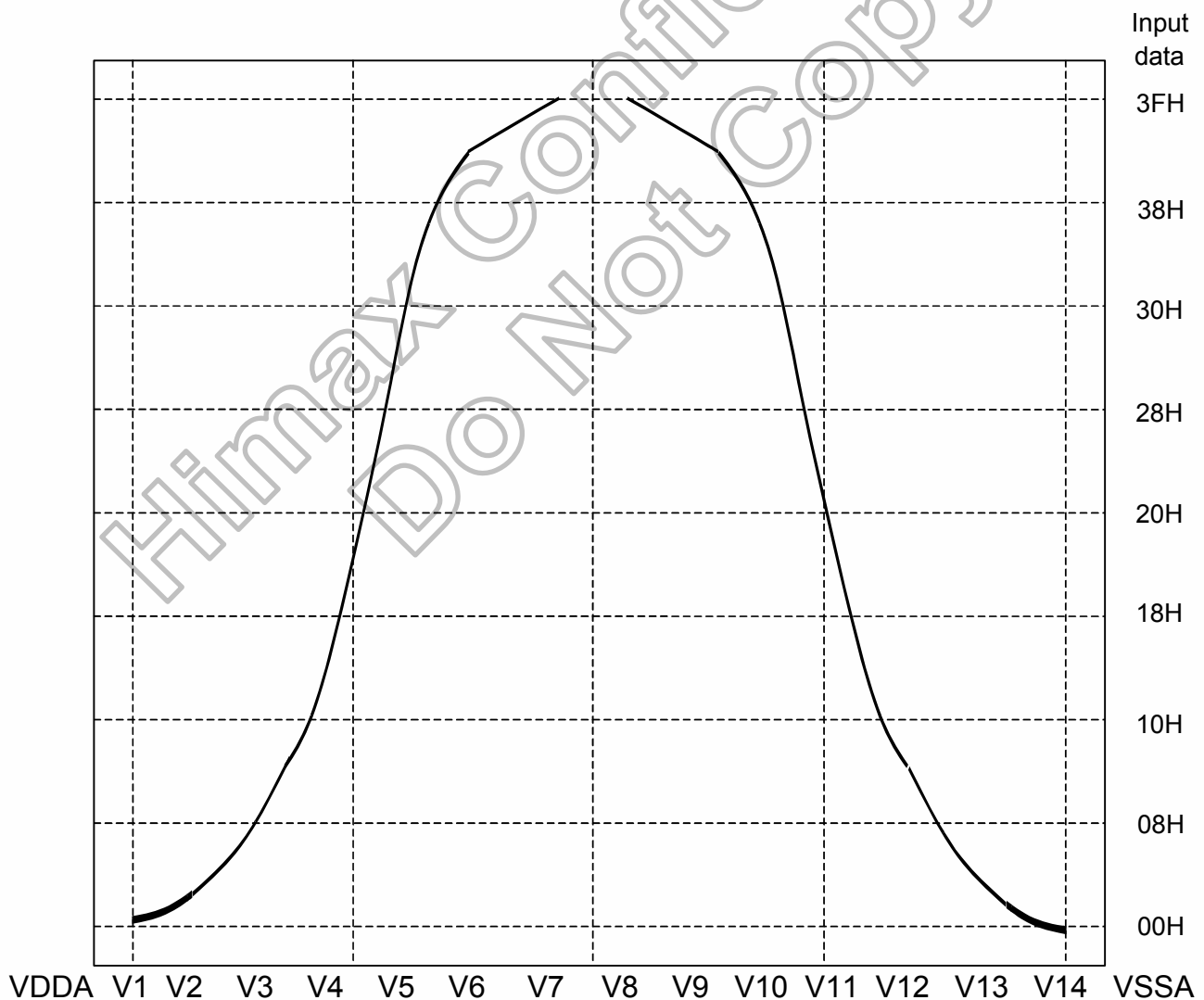

Figure 6. 1 Gamma Correction Characteristic Curve

REV = 0 data not inverted, for normally white panel (Default)
 VSET=0, 10 gamma voltage input, V2, V6, V9, V13 is disable (Default)
 Gamma correction resistor ratio: (1 unit = 125ohm)

	Name	Resistor	Name	Resistor	
V1, V14 →	R0	9.6	R32	0.8	← V4, V11
	R1	8.4	R33	0.8	
	R2	7.6	R34	0.8	
	R3	6.4	R35	0.8	
	R4	5.2	R36	0.8	
	R5	4.4	R37	0.8	
	R6	3.6	R38	0.8	
	R7	2.8	R39	0.8	
	R8	2.4	R40	0.8	
	R9	2.4	R41	0.8	
	R10	2	R42	0.8	
	R11	2	R43	0.8	
	R12	1.6	R44	0.8	
	R13	1.6	R45	0.8	
	R14	1.6	R46	0.8	
V3, V12 →	R15	1.2	R47	0.8	← V5, V10
	R16	1.2	R48	0.8	
	R17	1.2	R49	0.8	
	R18	1.2	R50	0.8	
	R19	1.2	R51	0.8	
	R20	1.2	R52	0.8	
	R21	1.2	R53	0.8	
	R22	0.8	R54	1.2	
	R23	0.8	R55	1.2	
	R24	0.8	R56	1.2	
	R25	0.8	R57	1.6	
	R26	0.8	R58	1.6	
	R27	0.8	R59	2	
	R28	0.8	R60	2.4	
	R29	0.8	R61	4	
	R30	0.8	R62	32.8	← V7, V8
V4, V11 →	R31	0.8			

REV = 0 data not inverted, for normally white panel (Default)
 VSET=1, 14 gamma voltage input
 Gamma correction resistor ratio: (1 unit = 125ohm)

	Name	Resistor	Name	Resistor	
V1, V14 →	R0	9.6	R32	0.8	← V4, V11
V2, V13 →	R1	8.4	R33	0.8	
	R2	7.6	R34	0.8	
	R3	6.4	R35	0.8	
	R4	5.2	R36	0.8	
	R5	4.4	R37	0.8	
	R6	3.6	R38	0.8	
	R7	2.8	R39	0.8	
	R8	2.4	R40	0.8	
	R9	2.4	R41	0.8	
	R10	2	R42	0.8	
	R11	2	R43	0.8	
	R12	1.6	R44	0.8	
	R13	1.6	R45	0.8	
	R14	1.6	R46	0.8	
V3, V12 →	R15	1.2	R47	0.8	← V5, V10
	R16	1.2	R48	0.8	
	R17	1.2	R49	0.8	
	R18	1.2	R50	0.8	
	R19	1.2	R51	0.8	
	R20	1.2	R52	0.8	
	R21	1.2	R53	0.8	
	R22	0.8	R54	1.2	
	R23	0.8	R55	1.2	
	R24	0.8	R56	1.2	
	R25	0.8	R57	1.6	
	R26	0.8	R58	1.6	
	R27	0.8	R59	2	
	R28	0.8	R60	2.4	
	R29	0.8	R61	4	← V6, V9
	R30	0.8	R62	32.8	← V7, V8
V4, V11 →	R31	0.8			

Output Voltages vs. Source Input Data

REV = 0 data not inverted, for normally white panel (Default)

VSET=0, 10 gamma voltage input, V2, V6, V9, V13 is disable (Default)

Data	Positive polarity Output Voltage	Negative polarity Output Voltage
00H	V1	V14
01H	$V3 + (V1 - V3) \times 53.2 / 62.8$	$V14 + (V12 - V14) \times 9.6 / 62.8$
02H	$V3 + (V1 - V3) \times 44.8 / 62.8$	$V14 + (V12 - V14) \times 18 / 62.8$
03H	$V3 + (V1 - V3) \times 37.2 / 62.8$	$V14 + (V12 - V14) \times 25.6 / 62.8$
04H	$V3 + (V1 - V3) \times 30.8 / 62.8$	$V14 + (V12 - V14) \times 32 / 62.8$
05H	$V3 + (V1 - V3) \times 25.6 / 62.8$	$V14 + (V12 - V14) \times 37.2 / 62.8$
06H	$V3 + (V1 - V3) \times 21.2 / 62.8$	$V14 + (V12 - V14) \times 41.6 / 62.8$
07H	$V3 + (V1 - V3) \times 17.6 / 62.8$	$V14 + (V12 - V14) \times 45.2 / 62.8$
08H	$V3 + (V1 - V3) \times 14.8 / 62.8$	$V14 + (V12 - V14) \times 48 / 62.8$
09H	$V3 + (V1 - V3) \times 12.4 / 62.8$	$V14 + (V12 - V14) \times 50.4 / 62.8$
0AH	$V3 + (V1 - V3) \times 10 / 62.8$	$V14 + (V12 - V14) \times 52.8 / 62.8$
0BH	$V3 + (V1 - V3) \times 8 / 62.8$	$V14 + (V12 - V14) \times 54.8 / 62.8$
0CH	$V3 + (V1 - V3) \times 6 / 62.8$	$V14 + (V12 - V14) \times 56.8 / 62.8$
0DH	$V3 + (V1 - V3) \times 4.4 / 62.8$	$V14 + (V12 - V14) \times 58.4 / 62.8$
0EH	$V3 + (V1 - V3) \times 2.8 / 62.8$	$V14 + (V12 - V14) \times 60 / 62.8$
0FH	$V3 + (V1 - V3) \times 1.2 / 62.8$	$V14 + (V12 - V14) \times 61.6 / 62.8$
10H	V3	V12
11H	$V4 + (V3 - V4) \times 14 / 15.2$	$V12 + (V11 - V12) \times 1.2 / 15.2$
12H	$V4 + (V3 - V4) \times 12.8 / 15.2$	$V12 + (V11 - V12) \times 2.4 / 15.2$
13H	$V4 + (V3 - V4) \times 11.6 / 15.2$	$V12 + (V11 - V12) \times 3.6 / 15.2$
14H	$V4 + (V3 - V4) \times 10.4 / 15.2$	$V12 + (V11 - V12) \times 4.8 / 15.2$
15H	$V4 + (V3 - V4) \times 9.2 / 15.2$	$V12 + (V11 - V12) \times 6 / 15.2$
16H	$V4 + (V3 - V4) \times 8 / 15.2$	$V12 + (V11 - V12) \times 7.2 / 15.2$
17H	$V4 + (V3 - V4) \times 7.2 / 15.2$	$V12 + (V11 - V12) \times 8 / 15.2$
18H	$V4 + (V3 - V4) \times 6.4 / 15.2$	$V12 + (V11 - V12) \times 8.8 / 15.2$
19H	$V4 + (V3 - V4) \times 5.6 / 15.2$	$V12 + (V11 - V12) \times 9.6 / 15.2$
1AH	$V4 + (V3 - V4) \times 4.8 / 15.2$	$V12 + (V11 - V12) \times 10.4 / 15.2$
1BH	$V4 + (V3 - V4) \times 4 / 15.2$	$V12 + (V11 - V12) \times 11.2 / 15.2$
1CH	$V4 + (V3 - V4) \times 3.2 / 15.2$	$V12 + (V11 - V12) \times 12 / 15.2$
1DH	$V4 + (V3 - V4) \times 2.4 / 15.2$	$V12 + (V11 - V12) \times 12.8 / 15.2$
1EH	$V4 + (V3 - V4) \times 1.6 / 15.2$	$V12 + (V11 - V12) \times 13.6 / 15.2$
1FH	$V4 + (V3 - V4) \times 0.8 / 15.2$	$V12 + (V11 - V12) \times 14.4 / 15.2$

Output Voltages vs. Source Input Data (continued):

REV = 0 data not inverted, for normally white panel (Default)

VSET=0, 10 gamma voltage input, V2, V6, V9, V13 is disable (Default)

Data	Positive polarity Output Voltage	Negative polarity Output Voltage
20H	V4	V11
21H	$V5 + (V4 - V5) \times 12 / 12.8$	$V11 + (V10 - V11) \times 0.8 / 12.8$
22H	$V5 + (V4 - V5) \times 11.2 / 12.8$	$V11 + (V10 - V11) \times 1.6 / 12.8$
23H	$V5 + (V4 - V5) \times 10.4 / 12.8$	$V11 + (V10 - V11) \times 2.4 / 12.8$
24H	$V5 + (V4 - V5) \times 9.6 / 12.8$	$V11 + (V10 - V11) \times 3.2 / 12.8$
25H	$V5 + (V4 - V5) \times 8.8 / 12.8$	$V11 + (V10 - V11) \times 4 / 12.8$
26H	$V5 + (V4 - V5) \times 8 / 12.8$	$V11 + (V10 - V11) \times 4.8 / 12.8$
27H	$V5 + (V4 - V5) \times 7.2 / 12.8$	$V11 + (V10 - V11) \times 5.6 / 12.8$
28H	$V5 + (V4 - V5) \times 6.4 / 12.8$	$V11 + (V10 - V11) \times 6.4 / 12.8$
29H	$V5 + (V4 - V5) \times 5.6 / 12.8$	$V11 + (V10 - V11) \times 7.2 / 12.8$
2AH	$V5 + (V4 - V5) \times 4.8 / 12.8$	$V11 + (V10 - V11) \times 8 / 12.8$
2BH	$V5 + (V4 - V5) \times 4 / 12.8$	$V11 + (V10 - V11) \times 8.8 / 12.8$
2CH	$V5 + (V4 - V5) \times 3.2 / 12.8$	$V11 + (V10 - V11) \times 9.6 / 12.8$
2DH	$V5 + (V4 - V5) \times 2.4 / 12.8$	$V11 + (V10 - V11) \times 10.4 / 12.8$
2EH	$V5 + (V4 - V5) \times 1.6 / 12.8$	$V11 + (V10 - V11) \times 11.2 / 12.8$
2FH	$V5 + (V4 - V5) \times 0.8 / 12.8$	$V11 + (V10 - V11) \times 12 / 12.8$
30H	V5	V10
31H	$V7 + (V5 - V7) \times 52 / 52.8$	$V10 + (V8 - V10) \times 0.8 / 52.8$
32H	$V7 + (V5 - V7) \times 51.2 / 52.8$	$V10 + (V8 - V10) \times 1.6 / 52.8$
33H	$V7 + (V5 - V7) \times 50.4 / 52.8$	$V10 + (V8 - V10) \times 2.4 / 52.8$
34H	$V7 + (V5 - V7) \times 49.6 / 52.8$	$V10 + (V8 - V10) \times 3.2 / 52.8$
35H	$V7 + (V5 - V7) \times 48.8 / 52.8$	$V10 + (V8 - V10) \times 4 / 52.8$
36H	$V7 + (V5 - V7) \times 48 / 52.8$	$V10 + (V8 - V10) \times 4.8 / 52.8$
37H	$V7 + (V5 - V7) \times 46.8 / 52.8$	$V10 + (V8 - V10) \times 6 / 52.8$
38H	$V7 + (V5 - V7) \times 45.6 / 52.8$	$V10 + (V8 - V10) \times 7.2 / 52.8$
39H	$V7 + (V5 - V7) \times 44.4 / 52.8$	$V10 + (V8 - V10) \times 8.4 / 52.8$
3AH	$V7 + (V5 - V7) \times 42.8 / 52.8$	$V10 + (V8 - V10) \times 10 / 52.8$
3BH	$V7 + (V5 - V7) \times 41.2 / 52.8$	$V10 + (V8 - V10) \times 11.6 / 52.8$
3CH	$V7 + (V5 - V7) \times 39.2 / 52.8$	$V10 + (V8 - V10) \times 13.6 / 52.8$
3DH	$V7 + (V5 - V7) \times 36.8 / 52.8$	$V10 + (V8 - V10) \times 16 / 52.8$
3EH	$V7 + (V5 - V7) \times 32.8 / 52.8$	$V10 + (V8 - V10) \times 20 / 52.8$
3FH	V7	V8

Output Voltages vs. Source Input Data

REV = 0 data not inverted, for normally white panel (Default)

VSET=1, 14 gamma voltage input

Data	Positive polarity Output Voltage	Negative polarity Output Voltage
00H	V1	V14
01H	V2	V13
02H	$V3 + (V1 - V3) \times 44.8 / 53.2$	$V14 + (V12 - V14) \times 8.4 / 53.2$
03H	$V3 + (V1 - V3) \times 37.2 / 53.2$	$V14 + (V12 - V14) \times 16 / 53.2$
04H	$V3 + (V1 - V3) \times 30.8 / 53.2$	$V14 + (V12 - V14) \times 22.4 / 53.2$
05H	$V3 + (V1 - V3) \times 25.6 / 53.2$	$V14 + (V12 - V14) \times 27.6 / 53.2$
06H	$V3 + (V1 - V3) \times 21.2 / 53.2$	$V14 + (V12 - V14) \times 32 / 53.2$
07H	$V3 + (V1 - V3) \times 17.6 / 53.2$	$V14 + (V12 - V14) \times 35.6 / 53.2$
08H	$V3 + (V1 - V3) \times 14.8 / 53.2$	$V14 + (V12 - V14) \times 38.4 / 53.2$
09H	$V3 + (V1 - V3) \times 12.4 / 53.2$	$V14 + (V12 - V14) \times 40.8 / 53.2$
0AH	$V3 + (V1 - V3) \times 10 / 53.2$	$V14 + (V12 - V14) \times 43.2 / 53.2$
0BH	$V3 + (V1 - V3) \times 8 / 53.2$	$V14 + (V12 - V14) \times 45.2 / 53.2$
0CH	$V3 + (V1 - V3) \times 6 / 53.2$	$V14 + (V12 - V14) \times 47.2 / 53.2$
0DH	$V3 + (V1 - V3) \times 4.4 / 53.2$	$V14 + (V12 - V14) \times 48.8 / 53.2$
0EH	$V3 + (V1 - V3) \times 2.8 / 53.2$	$V14 + (V12 - V14) \times 50.4 / 53.2$
0FH	$V3 + (V1 - V3) \times 1.2 / 53.2$	$V14 + (V12 - V14) \times 52 / 53.2$
10H	V3	V12
11H	$V4 + (V3 - V4) \times 14 / 15.2$	$V12 + (V11 - V12) \times 1.2 / 15.2$
12H	$V4 + (V3 - V4) \times 12.8 / 15.2$	$V12 + (V11 - V12) \times 2.4 / 15.2$
13H	$V4 + (V3 - V4) \times 11.6 / 15.2$	$V12 + (V11 - V12) \times 3.6 / 15.2$
14H	$V4 + (V3 - V4) \times 10.4 / 15.2$	$V12 + (V11 - V12) \times 4.8 / 15.2$
15H	$V4 + (V3 - V4) \times 9.2 / 15.2$	$V12 + (V11 - V12) \times 6 / 15.2$
16H	$V4 + (V3 - V4) \times 8 / 15.2$	$V12 + (V11 - V12) \times 7.2 / 15.2$
17H	$V4 + (V3 - V4) \times 7.2 / 15.2$	$V12 + (V11 - V12) \times 8 / 15.2$
18H	$V4 + (V3 - V4) \times 6.4 / 15.2$	$V12 + (V11 - V12) \times 8.8 / 15.2$
19H	$V4 + (V3 - V4) \times 5.6 / 15.2$	$V12 + (V11 - V12) \times 9.6 / 15.2$
1AH	$V4 + (V3 - V4) \times 4.8 / 15.2$	$V12 + (V11 - V12) \times 10.4 / 15.2$
1BH	$V4 + (V3 - V4) \times 4 / 15.2$	$V12 + (V11 - V12) \times 11.2 / 15.2$
1CH	$V4 + (V3 - V4) \times 3.2 / 15.2$	$V12 + (V11 - V12) \times 12 / 15.2$
1DH	$V4 + (V3 - V4) \times 2.4 / 15.2$	$V12 + (V11 - V12) \times 12.8 / 15.2$
1EH	$V4 + (V3 - V4) \times 1.6 / 15.2$	$V12 + (V11 - V12) \times 13.6 / 15.2$
1FH	$V4 + (V3 - V4) \times 0.8 / 15.2$	$V12 + (V11 - V12) \times 14.4 / 15.2$

Output Voltages vs. Source Input Data (continued):
 REV = 0 data not inverted, for normally white panel (Default)
 VSET=1, 14 gamma voltage input

Data	Positive polarity Output Voltage	Negative polarity Output Voltage
20H	V4	V11
21H	$V5 + (V4 - V5) \times 12 / 12.8$	$V11 + (V10 - V11) \times 0.8 / 12.8$
22H	$V5 + (V4 - V5) \times 11.2 / 12.8$	$V11 + (V10 - V11) \times 1.6 / 12.8$
23H	$V5 + (V4 - V5) \times 10.4 / 12.8$	$V11 + (V10 - V11) \times 2.4 / 12.8$
24H	$V5 + (V4 - V5) \times 9.6 / 12.8$	$V11 + (V10 - V11) \times 3.2 / 12.8$
25H	$V5 + (V4 - V5) \times 8.8 / 12.8$	$V11 + (V10 - V11) \times 4 / 12.8$
26H	$V5 + (V4 - V5) \times 8 / 12.8$	$V11 + (V10 - V11) \times 4.8 / 12.8$
27H	$V5 + (V4 - V5) \times 7.2 / 12.8$	$V11 + (V10 - V11) \times 5.6 / 12.8$
28H	$V5 + (V4 - V5) \times 6.4 / 12.8$	$V11 + (V10 - V11) \times 6.4 / 12.8$
29H	$V5 + (V4 - V5) \times 5.6 / 12.8$	$V11 + (V10 - V11) \times 7.2 / 12.8$
2AH	$V5 + (V4 - V5) \times 4.8 / 12.8$	$V11 + (V10 - V11) \times 8 / 12.8$
2BH	$V5 + (V4 - V5) \times 4 / 12.8$	$V11 + (V10 - V11) \times 8.8 / 12.8$
2CH	$V5 + (V4 - V5) \times 3.2 / 12.8$	$V11 + (V10 - V11) \times 9.6 / 12.8$
2DH	$V5 + (V4 - V5) \times 2.4 / 12.8$	$V11 + (V10 - V11) \times 10.4 / 12.8$
2EH	$V5 + (V4 - V5) \times 1.6 / 12.8$	$V11 + (V10 - V11) \times 11.2 / 12.8$
2FH	$V5 + (V4 - V5) \times 0.8 / 12.8$	$V11 + (V10 - V11) \times 12 / 12.8$
30H	V5	V10
31H	$V7 + (V5 - V7) \times 19.2 / 20$	$V10 + (V8 - V10) \times 0.8 / 52.8$
32H	$V7 + (V5 - V7) \times 18.4 / 20$	$V10 + (V8 - V10) \times 1.6 / 52.8$
33H	$V7 + (V5 - V7) \times 17.6 / 20$	$V10 + (V8 - V10) \times 2.4 / 52.8$
34H	$V7 + (V5 - V7) \times 16.8 / 20$	$V10 + (V8 - V10) \times 3.2 / 52.8$
35H	$V7 + (V5 - V7) \times 16 / 20$	$V10 + (V8 - V10) \times 4 / 52.8$
36H	$V7 + (V5 - V7) \times 15.2 / 20$	$V10 + (V8 - V10) \times 4.8 / 52.8$
37H	$V7 + (V5 - V7) \times 14 / 20$	$V10 + (V8 - V10) \times 6 / 52.8$
38H	$V7 + (V5 - V7) \times 12.8 / 20$	$V10 + (V8 - V10) \times 7.2 / 52.8$
39H	$V7 + (V5 - V7) \times 11.6 / 20$	$V10 + (V8 - V10) \times 8.4 / 52.8$
3AH	$V7 + (V5 - V7) \times 10 / 20$	$V10 + (V8 - V10) \times 10 / 52.8$
3BH	$V7 + (V5 - V7) \times 8.4 / 20$	$V10 + (V8 - V10) \times 11.6 / 52.8$
3CH	$V7 + (V5 - V7) \times 6.4 / 20$	$V10 + (V8 - V10) \times 13.6 / 52.8$
3DH	$V7 + (V5 - V7) \times 4 / 20$	$V10 + (V8 - V10) \times 16 / 52.8$
3EH	V6	V9
3FH	V7	V8

REV = 1 data inverted, for normally black panel
 VSET=0, 10 gamma voltage input, V2, V6, V9, V13 is disable (Default)
 Gamma correction resistor ratio: (1 unit = 125ohm)

Positive gamma

	Name	Resistor	Name	Resistor	
V1 →	R0	6	R32	1.2	← V4
	R1	8	R33	0.8	
	R2	6	R34	0.8	
	R3	5.2	R35	0.8	
	R4	4	R36	0.8	
	R5	3.2	R37	0.8	
	R6	2.8	R38	0.8	
	R7	2.4	R39	0.8	
	R8	2	R40	0.8	
	R9	2	R41	0.8	
	R10	1.6	R42	0.8	
	R11	1.6	R43	0.8	
	R12	1.6	R44	0.8	
	R13	1.6	R45	0.8	
	R14	1.6	R46	0.8	
	R15	1.6	R47	0.8	
V3 →	R16	1.6	R48	0.8	← V5
	R17	1.6	R49	0.8	
	R18	1.6	R50	0.8	
	R19	1.2	R51	0.8	
	R20	1.2	R52	0.8	
	R21	1.2	R53	0.8	
	R22	1.2	R54	0.8	
	R23	1.2	R55	0.8	
	R24	0.8	R56	0.8	
	R25	0.8	R57	1.2	
	R26	0.8	R58	2.8	
	R27	0.8	R59	3.6	
	R28	0.8	R60	6	
	R29	0.8	R61	7.6	
	R30	0.8	R62	12.8	← V7
V4 →	R31	1.2			

REV = 1 data inverted, for normally black panel

VSET=0, 10 gamma voltage input, V2, V6, V9, V13 is disable (Default)

Negative gamma

	Name	Resistor	Name	Resistor	
V14 →	R0	8	R32	0.8	← V11
	R1	11.2	R33	0.8	
	R2	8	R34	0.8	
	R3	6.8	R35	0.8	
	R4	5.2	R36	0.8	
	R5	4.8	R37	0.8	
	R6	4	R38	0.8	
	R7	3.2	R39	0.8	
	R8	2.8	R40	0.8	
	R9	2.8	R41	0.8	
	R10	2.4	R42	0.8	
	R11	2	R43	0.8	
	R12	2	R44	0.8	
	R13	2	R45	0.8	
	R14	1.6	R46	0.8	
	R15	1.2	R47	0.8	
V12 →	R16	1.2	R48	0.8	← V10
	R17	0.8	R49	0.8	
	R18	0.8	R50	0.8	
	R19	0.8	R51	1.2	
	R20	0.6	R52	1.2	
	R21	0.4	R53	1.2	
	R22	0.4	R54	1.6	
	R23	0.4	R55	1.6	
	R24	0.4	R56	2	
	R25	0.4	R57	2.4	
	R26	0.4	R58	2.4	
	R27	0.4	R59	3.2	
	R28	0.4	R60	3.2	
	R29	0.4	R61	6	
	R30	0.4	R62	5.6	← V8
V11 →	R31	0.6			

REV = 1 data inverted, for normally black panel
 VSET=1, 14 gamma voltage input
 Positive gamma

	Name	Resistor	Name	Resistor	
V1 →	R0	6	R32	1.2	← V4
V2 →	R1	8	R33	0.8	
	R2	6	R34	0.8	
	R3	5.2	R35	0.8	
	R4	4	R36	0.8	
	R5	3.2	R37	0.8	
	R6	2.8	R38	0.8	
	R7	2.4	R39	0.8	
	R8	2	R40	0.8	
	R9	2	R41	0.8	
	R10	1.6	R42	0.8	
	R11	1.6	R43	0.8	
	R12	1.6	R44	0.8	
	R13	1.6	R45	0.8	
	R14	1.6	R46	0.8	
	R15	1.6	R47	0.8	
V3 →	R16	1.6	R48	0.8	← V5
	R17	1.6	R49	0.8	
	R18	1.6	R50	0.8	
	R19	1.2	R51	0.8	
	R20	1.2	R52	0.8	
	R21	1.2	R53	0.8	
	R22	1.2	R54	0.8	
	R23	1.2	R55	0.8	
	R24	0.8	R56	0.8	
	R25	0.8	R57	1.2	
	R26	0.8	R58	2.8	
	R27	0.8	R59	3.6	
	R28	0.8	R60	6	
	R29	0.8	R61	7.6	← V6
	R30	0.8	R62	12.8	← V7
V4 →	R31	1.2			

REV = 1 data inverted, for normally black panel
 VSET=1, 14 gamma voltage input
 Negative gamma

	Name	Resistor	Name	Resistor	
V14 →	R0	8	R32	0.8	← V11
V13 →	R1	11.2	R33	0.8	
	R2	8	R34	0.8	
	R3	6.8	R35	0.8	
	R4	5.2	R36	0.8	
	R5	4.8	R37	0.8	
	R6	4	R38	0.8	
	R7	3.2	R39	0.8	
	R8	2.8	R40	0.8	
	R9	2.8	R41	0.8	
	R10	2.4	R42	0.8	
	R11	2	R43	0.8	
	R12	2	R44	0.8	
	R13	2	R45	0.8	
	R14	1.6	R46	0.8	
V12 →	R15	1.2	R47	0.8	← V10
	R16	1.2	R48	0.8	
	R17	0.8	R49	0.8	
	R18	0.8	R50	0.8	
	R19	0.8	R51	1.2	
	R20	0.6	R52	1.2	
	R21	0.4	R53	1.2	
	R22	0.4	R54	1.6	
	R23	0.4	R55	1.6	
	R24	0.4	R56	2	
	R25	0.4	R57	2.4	
	R26	0.4	R58	2.4	
	R27	0.4	R59	3.2	
	R28	0.4	R60	3.2	
	R29	0.4	R61	6	← V9
	R30	0.4	R62	5.6	← V8
V11 →	R31	0.6			

Output Voltages vs. Source Input Data

REV = 1 data inverted, for normally black panel

VSET=0, 10 gamma voltage input, V2, V6, V9, V13 is disable (Default)

Data	Positive polarity Output Voltage	Negative polarity Output Voltage
00H	V1	V14
01H	$V3 + (V1 - V3) \times 45.2 / 51.2$	$V14 + (V12 - V14) \times 8 / 68$
02H	$V3 + (V1 - V3) \times 37.2 / 51.2$	$V14 + (V12 - V14) \times 19.2 / 68$
03H	$V3 + (V1 - V3) \times 31.2 / 51.2$	$V14 + (V12 - V14) \times 27.2 / 68$
04H	$V3 + (V1 - V3) \times 26 / 51.2$	$V14 + (V12 - V14) \times 34 / 68$
05H	$V3 + (V1 - V3) \times 22 / 51.2$	$V14 + (V12 - V14) \times 39.2 / 68$
06H	$V3 + (V1 - V3) \times 18.8 / 51.2$	$V14 + (V12 - V14) \times 44 / 68$
07H	$V3 + (V1 - V3) \times 16 / 51.2$	$V14 + (V12 - V14) \times 48 / 68$
08H	$V3 + (V1 - V3) \times 13.6 / 51.2$	$V14 + (V12 - V14) \times 51.2 / 68$
09H	$V3 + (V1 - V3) \times 11.6 / 51.2$	$V14 + (V12 - V14) \times 54 / 68$
0AH	$V3 + (V1 - V3) \times 9.6 / 51.2$	$V14 + (V12 - V14) \times 56.8 / 68$
0BH	$V3 + (V1 - V3) \times 8 / 51.2$	$V14 + (V12 - V14) \times 59.2 / 68$
0CH	$V3 + (V1 - V3) \times 6.4 / 51.2$	$V14 + (V12 - V14) \times 61.2 / 68$
0DH	$V3 + (V1 - V3) \times 4.8 / 51.2$	$V14 + (V12 - V14) \times 63.2 / 68$
0EH	$V3 + (V1 - V3) \times 3.2 / 51.2$	$V14 + (V12 - V14) \times 65.2 / 68$
0FH	$V3 + (V1 - V3) \times 1.6 / 51.2$	$V14 + (V12 - V14) \times 66.8 / 68$
10H	V3	V12
11H	$V4 + (V3 - V4) \times 16 / 17.6$	$V12 + (V11 - V12) \times 1.2 / 8.8$
12H	$V4 + (V3 - V4) \times 14.4 / 17.6$	$V12 + (V11 - V12) \times 2 / 8.8$
13H	$V4 + (V3 - V4) \times 12.8 / 17.6$	$V12 + (V11 - V12) \times 2.8 / 8.8$
14H	$V4 + (V3 - V4) \times 11.6 / 17.6$	$V12 + (V11 - V12) \times 3.6 / 8.8$
15H	$V4 + (V3 - V4) \times 10.4 / 17.6$	$V12 + (V11 - V12) \times 4.2 / 8.8$
16H	$V4 + (V3 - V4) \times 9.2 / 17.6$	$V12 + (V11 - V12) \times 4.6 / 8.8$
17H	$V4 + (V3 - V4) \times 8 / 17.6$	$V12 + (V11 - V12) \times 5 / 8.8$
18H	$V4 + (V3 - V4) \times 6.8 / 17.6$	$V12 + (V11 - V12) \times 5.4 / 8.8$
19H	$V4 + (V3 - V4) \times 6 / 17.6$	$V12 + (V11 - V12) \times 5.8 / 8.8$
1AH	$V4 + (V3 - V4) \times 5.2 / 17.6$	$V12 + (V11 - V12) \times 6.2 / 8.8$
1BH	$V4 + (V3 - V4) \times 4.4 / 17.6$	$V12 + (V11 - V12) \times 6.6 / 8.8$
1CH	$V4 + (V3 - V4) \times 3.6 / 17.6$	$V12 + (V11 - V12) \times 7 / 8.8$
1DH	$V4 + (V3 - V4) \times 2.8 / 17.6$	$V12 + (V11 - V12) \times 7.4 / 8.8$
1EH	$V4 + (V3 - V4) \times 2 / 17.6$	$V12 + (V11 - V12) \times 7.8 / 8.8$
1FH	$V4 + (V3 - V4) \times 1.2 / 17.6$	$V12 + (V11 - V12) \times 8.2 / 8.8$

Output Voltages vs. Source Input Data (continued):

REV = 1 data inverted, for normally black panel

VSET=0, 10 gamma voltage input, V2, V6, V9, V13 is disable (Default)

Data	Positive polarity Output Voltage	Negative polarity Output Voltage
20H	V4	V11
21H	$V5 + (V4 - V5) \times 12 / 13.2$	$V11 + (V10 - V11) \times 0.8 / 12.8$
22H	$V5 + (V4 - V5) \times 11.2 / 13.2$	$V11 + (V10 - V11) \times 1.6 / 12.8$
23H	$V5 + (V4 - V5) \times 10.4 / 13.2$	$V11 + (V10 - V11) \times 2.4 / 12.8$
24H	$V5 + (V4 - V5) \times 9.6 / 13.2$	$V11 + (V10 - V11) \times 3.2 / 12.8$
25H	$V5 + (V4 - V5) \times 8.8 / 13.2$	$V11 + (V10 - V11) \times 4 / 12.8$
26H	$V5 + (V4 - V5) \times 8 / 13.2$	$V11 + (V10 - V11) \times 4.8 / 12.8$
27H	$V5 + (V4 - V5) \times 7.2 / 13.2$	$V11 + (V10 - V11) \times 5.6 / 12.8$
28H	$V5 + (V4 - V5) \times 6.4 / 13.2$	$V11 + (V10 - V11) \times 6.4 / 12.8$
29H	$V5 + (V4 - V5) \times 5.6 / 13.2$	$V11 + (V10 - V11) \times 7.2 / 12.8$
2AH	$V5 + (V4 - V5) \times 4.8 / 13.2$	$V11 + (V10 - V11) \times 8 / 12.8$
2BH	$V5 + (V4 - V5) \times 4 / 13.2$	$V11 + (V10 - V11) \times 8.8 / 12.8$
2CH	$V5 + (V4 - V5) \times 3.2 / 13.2$	$V11 + (V10 - V11) \times 9.6 / 12.8$
2DH	$V5 + (V4 - V5) \times 2.4 / 13.2$	$V11 + (V10 - V11) \times 10.4 / 12.8$
2EH	$V5 + (V4 - V5) \times 1.6 / 13.2$	$V11 + (V10 - V11) \times 11.2 / 12.8$
2FH	$V5 + (V4 - V5) \times 0.8 / 13.2$	$V11 + (V10 - V11) \times 12 / 12.8$
30H	V5	V10
31H	$V7 + (V5 - V7) \times 40.4 / 41.2$	$V10 + (V8 - V10) \times 0.8 / 34$
32H	$V7 + (V5 - V7) \times 39.6 / 41.2$	$V10 + (V8 - V10) \times 1.6 / 34$
33H	$V7 + (V5 - V7) \times 38.8 / 41.2$	$V10 + (V8 - V10) \times 2.4 / 34$
34H	$V7 + (V5 - V7) \times 38 / 41.2$	$V10 + (V8 - V10) \times 3.6 / 34$
35H	$V7 + (V5 - V7) \times 37.2 / 41.2$	$V10 + (V8 - V10) \times 4.8 / 34$
36H	$V7 + (V5 - V7) \times 36.4 / 41.2$	$V10 + (V8 - V10) \times 6 / 34$
37H	$V7 + (V5 - V7) \times 35.6 / 41.2$	$V10 + (V8 - V10) \times 7.6 / 34$
38H	$V7 + (V5 - V7) \times 34.8 / 41.2$	$V10 + (V8 - V10) \times 9.2 / 34$
39H	$V7 + (V5 - V7) \times 34 / 41.2$	$V10 + (V8 - V10) \times 11.2 / 34$
3AH	$V7 + (V5 - V7) \times 32.8 / 41.2$	$V10 + (V8 - V10) \times 13.6 / 34$
3BH	$V7 + (V5 - V7) \times 30 / 41.2$	$V10 + (V8 - V10) \times 16 / 34$
3CH	$V7 + (V5 - V7) \times 26.4 / 41.2$	$V10 + (V8 - V10) \times 19.2 / 34$
3DH	$V7 + (V5 - V7) \times 20.4 / 41.2$	$V10 + (V8 - V10) \times 22.4 / 34$
3EH	$V7 + (V5 - V7) \times 12.8 / 41.2$	$V10 + (V8 - V10) \times 28.4 / 34$
3FH	V7	V8

Output Voltages vs. Source Input Data
 REV = 1 data inverted, for normally black panel
 VSET=1, 14 gamma voltage input

Data	Positive polarity Output Voltage	Negative polarity Output Voltage
00H	V1	V14
01H	V2	V13
02H	$V3 + (V1 - V3) \times 37.2 / 51.2$	$V14 + (V12 - V14) \times 11.2 / 60$
03H	$V3 + (V1 - V3) \times 31.2 / 51.2$	$V14 + (V12 - V14) \times 19.2 / 60$
04H	$V3 + (V1 - V3) \times 26 / 51.2$	$V14 + (V12 - V14) \times 26 / 60$
05H	$V3 + (V1 - V3) \times 22 / 51.2$	$V14 + (V12 - V14) \times 31.2 / 60$
06H	$V3 + (V1 - V3) \times 18.8 / 51.2$	$V14 + (V12 - V14) \times 36 / 60$
07H	$V3 + (V1 - V3) \times 16 / 51.2$	$V14 + (V12 - V14) \times 40 / 60$
08H	$V3 + (V1 - V3) \times 13.6 / 51.2$	$V14 + (V12 - V14) \times 43.2 / 60$
09H	$V3 + (V1 - V3) \times 11.6 / 51.2$	$V14 + (V12 - V14) \times 46 / 60$
0AH	$V3 + (V1 - V3) \times 9.6 / 51.2$	$V14 + (V12 - V14) \times 48.8 / 60$
0BH	$V3 + (V1 - V3) \times 8 / 51.2$	$V14 + (V12 - V14) \times 51.2 / 60$
0CH	$V3 + (V1 - V3) \times 6.4 / 51.2$	$V14 + (V12 - V14) \times 53.2 / 60$
0DH	$V3 + (V1 - V3) \times 4.8 / 51.2$	$V14 + (V12 - V14) \times 55.2 / 60$
0EH	$V3 + (V1 - V3) \times 3.2 / 51.2$	$V14 + (V12 - V14) \times 57.2 / 60$
0FH	$V3 + (V1 - V3) \times 1.6 / 51.2$	$V14 + (V12 - V14) \times 58.8 / 60$
10H	V3	V12
11H	$V4 + (V3 - V4) \times 16 / 17.6$	$V12 + (V11 - V12) \times 1.2 / 8.8$
12H	$V4 + (V3 - V4) \times 14.4 / 17.6$	$V12 + (V11 - V12) \times 2 / 8.8$
13H	$V4 + (V3 - V4) \times 12.8 / 17.6$	$V12 + (V11 - V12) \times 2.8 / 8.8$
14H	$V4 + (V3 - V4) \times 11.6 / 17.6$	$V12 + (V11 - V12) \times 3.6 / 8.8$
15H	$V4 + (V3 - V4) \times 10.4 / 17.6$	$V12 + (V11 - V12) \times 4.2 / 8.8$
16H	$V4 + (V3 - V4) \times 9.2 / 17.6$	$V12 + (V11 - V12) \times 4.6 / 8.8$
17H	$V4 + (V3 - V4) \times 8 / 17.6$	$V12 + (V11 - V12) \times 5 / 8.8$
18H	$V4 + (V3 - V4) \times 6.8 / 17.6$	$V12 + (V11 - V12) \times 5.4 / 8.8$
19H	$V4 + (V3 - V4) \times 6 / 17.6$	$V12 + (V11 - V12) \times 5.8 / 8.8$
1AH	$V4 + (V3 - V4) \times 5.2 / 17.6$	$V12 + (V11 - V12) \times 6.2 / 8.8$
1BH	$V4 + (V3 - V4) \times 4.4 / 17.6$	$V12 + (V11 - V12) \times 6.6 / 8.8$
1CH	$V4 + (V3 - V4) \times 3.6 / 17.6$	$V12 + (V11 - V12) \times 7 / 8.8$
1DH	$V4 + (V3 - V4) \times 2.8 / 17.6$	$V12 + (V11 - V12) \times 7.4 / 8.8$
1EH	$V4 + (V3 - V4) \times 2 / 17.6$	$V12 + (V11 - V12) \times 7.8 / 8.8$
1FH	$V4 + (V3 - V4) \times 1.2 / 17.6$	$V12 + (V11 - V12) \times 8.2 / 8.8$

Output Voltages vs. Source Input Data (continued):

REV = 1 data inverted, for normally black panel

VSET=1, 14 gamma voltage input

Data	Positive polarity Output Voltage	Negative polarity Output Voltage
20H	V4	V11
21H	$V5 + (V4 - V5) \times 12 / 13.2$	$V11 + (V10 - V11) \times 0.8 / 12.8$
22H	$V5 + (V4 - V5) \times 11.2 / 13.2$	$V11 + (V10 - V11) \times 1.6 / 12.8$
23H	$V5 + (V4 - V5) \times 10.4 / 13.2$	$V11 + (V10 - V11) \times 2.4 / 12.8$
24H	$V5 + (V4 - V5) \times 9.6 / 13.2$	$V11 + (V10 - V11) \times 3.2 / 12.8$
25H	$V5 + (V4 - V5) \times 8.8 / 13.2$	$V11 + (V10 - V11) \times 4 / 12.8$
26H	$V5 + (V4 - V5) \times 8 / 13.2$	$V11 + (V10 - V11) \times 4.8 / 12.8$
27H	$V5 + (V4 - V5) \times 7.2 / 13.2$	$V11 + (V10 - V11) \times 5.6 / 12.8$
28H	$V5 + (V4 - V5) \times 6.4 / 13.2$	$V11 + (V10 - V11) \times 6.4 / 12.8$
29H	$V5 + (V4 - V5) \times 5.6 / 13.2$	$V11 + (V10 - V11) \times 7.2 / 12.8$
2AH	$V5 + (V4 - V5) \times 4.8 / 13.2$	$V11 + (V10 - V11) \times 8 / 12.8$
2BH	$V5 + (V4 - V5) \times 4 / 13.2$	$V11 + (V10 - V11) \times 8.8 / 12.8$
2CH	$V5 + (V4 - V5) \times 3.2 / 13.2$	$V11 + (V10 - V11) \times 9.6 / 12.8$
2DH	$V5 + (V4 - V5) \times 2.4 / 13.2$	$V11 + (V10 - V11) \times 10.4 / 12.8$
2EH	$V5 + (V4 - V5) \times 1.6 / 13.2$	$V11 + (V10 - V11) \times 11.2 / 12.8$
2FH	$V5 + (V4 - V5) \times 0.8 / 13.2$	$V11 + (V10 - V11) \times 12 / 12.8$
30H	V5	V10
31H	$V7 + (V5 - V7) \times 40.4 / 41.2$	$V10 + (V8 - V10) \times 0.8 / 34$
32H	$V7 + (V5 - V7) \times 39.6 / 41.2$	$V10 + (V8 - V10) \times 1.6 / 34$
33H	$V7 + (V5 - V7) \times 38.8 / 41.2$	$V10 + (V8 - V10) \times 2.4 / 34$
34H	$V7 + (V5 - V7) \times 38 / 41.2$	$V10 + (V8 - V10) \times 3.6 / 34$
35H	$V7 + (V5 - V7) \times 37.2 / 41.2$	$V10 + (V8 - V10) \times 4.8 / 34$
36H	$V7 + (V5 - V7) \times 36.4 / 41.2$	$V10 + (V8 - V10) \times 6 / 34$
37H	$V7 + (V5 - V7) \times 35.6 / 41.2$	$V10 + (V8 - V10) \times 7.6 / 34$
38H	$V7 + (V5 - V7) \times 34.8 / 41.2$	$V10 + (V8 - V10) \times 9.2 / 34$
39H	$V7 + (V5 - V7) \times 34 / 41.2$	$V10 + (V8 - V10) \times 11.2 / 34$
3AH	$V7 + (V5 - V7) \times 32.8 / 41.2$	$V10 + (V8 - V10) \times 13.6 / 34$
3BH	$V7 + (V5 - V7) \times 30 / 41.2$	$V10 + (V8 - V10) \times 16 / 34$
3CH	$V7 + (V5 - V7) \times 26.4 / 41.2$	$V10 + (V8 - V10) \times 19.2 / 34$
3DH	$V7 + (V5 - V7) \times 20.4 / 41.2$	$V10 + (V8 - V10) \times 22.4 / 34$
3EH	V6	V9
3FH	V7	V8

7. CABC (Content Adaptive Brightness Control)

HX8264-D02 supports content adaptive brightness control (CABC) function to reduce the power consumption of back light driver, depend on the image data output PWM pulse to back light driver for brightness control. It control backlight brightness intelligently by analyzing the display content which saves power, enhances contrast while maintaining vivid display quality.

The dimming algorithm enables a smooth backlight adjustment even when the content and brightness are swiftly changing.

CABC function can be configured by hardware control pin or software commends via SPI mode.

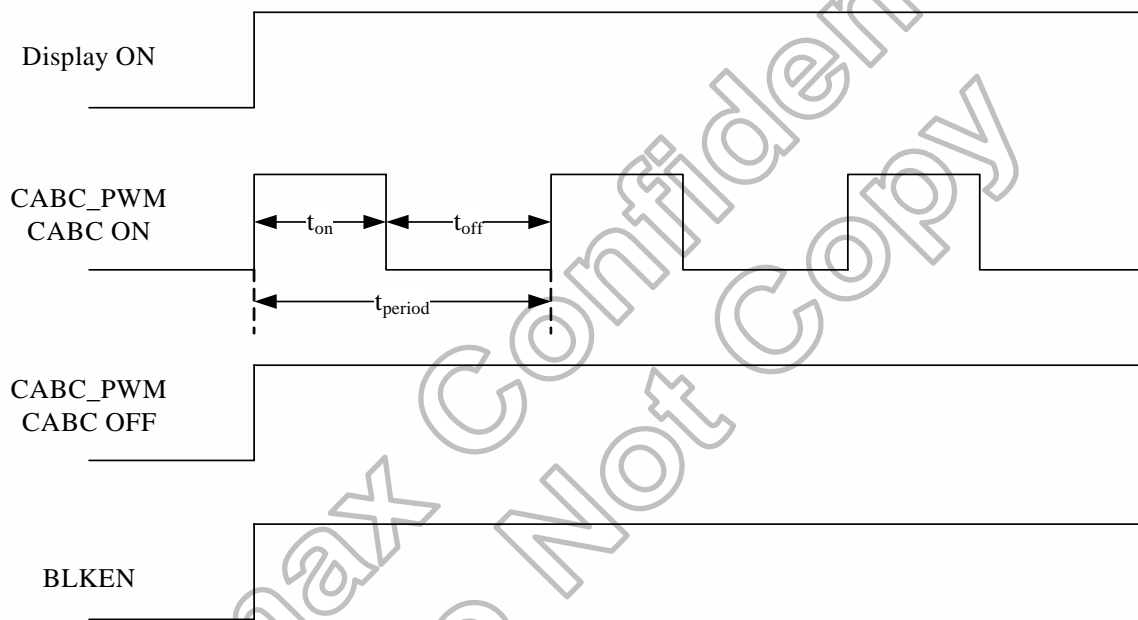

7.1 CABC Hardware Control

CABC_EN	DBC3	SDA/DBC[M][1]	SCL/DBC[M][0]	Function
0	X	X	X	CABC Disable
1	0	0	1	CABC Disable
1	0	0	0	UI mode (User Interface Image)
1	0	1	0	Moving mode (Moving Picture Image)
1	0	1	1	Still mode (Still Picture Image)
1	1	X	X	CABC software SPI control

7.2 CABC Software SPI Control

CABC Register Table

Register	Name	Default	Description	Note
R82h	CABC_CTL	0x30	[7:6]: Reserved [5:4]: CABC mode selection 00: Bypass mode 01: UI mode 10: Still mode 11: Moving mode (Default) [3:0]: Reserved	
R51h	BYPASS_DUTY	0xFF	[7:0]: CABC bypass mode duty cycle When 0x82=00h, CABC duty cycle is fixed by R51h	
R53h	CABC_FUN1	0x0C	[7:4]: Reserved [3]: ENDIM, Dimming function enable and disable 0: Disable 1: Enable (Default) [2]: BL, Back light is controlled by CABC function 0: Back light OFF 1: Back light ON (Default) [1:0]: Reserved	
R59h	DRV_FRE_A	0x00	[7:3]: Reserved [2:0]: DRV_FRE_A, parameter A of adjusting PWM period	
R5Eh	CABC_MB	0x80	[7:0]: CABC_MB, Minimum duty constraint (minimum brightness)	
R60h	DRV_FRE_B	0x04	[7:0]: DRV_FRE_B, parameter B of adjusting PWM period	
R65h	DIMT	0x21	[7:6]: Reserved [5:4]: DIM_A, total dimming time parameter A [1:0]: DIM_B, total dimming time parameter B Total dimming time = DIM_A x DIM_B (unit: frame)	
R70h	DBG_0	0x70	CABC curve user define gray level 0	
R71h	DBG_1	0xAC	CABC curve user define gray level 32	
R72h	DBG_2	0xC0	CABC curve user define gray level 64	
R73h	DBG_3	0xCD	CABC curve user define gray level 96	
R74h	DBG_4	0xD6	CABC curve user define gray level 128	
R75h	DBG_5	0xE0	CABC curve user define gray level 160	
R76h	DBG_6	0xEC	CABC curve user define gray level 192	
R77h	DBG_7	0xF8	CABC curve user define gray level 224	
R78h	DBG_8	0xFF	CABC curve user define gray level 255	

Note: 1. The un-addressed registers and reserved bit can't be written any data; otherwise the fault function is possible.

2. All CABC parameter registers (R59h, R5Eh, R60h, R65h and R70h~R78h) access must before end of the power on sequence or enter standby mode or CABC_EN="0".
3. R70h~R78h default value depend on R82h[5:4] CABC mode selection

7.3 Command Description

R82h:

No.	R/W	Address								Default setting value							
R82	R/W	A7	A6	A5	A4	A3	A2	A1	A0	D7	D6	D5	D4	D3	D2	D1	D0
	1/0	1	0	0	0	0	0	1	0	0	0	1	1	0	0	0	0

R82h [5:4]: CABC_CTL, content adaptive brightness control mode

R82h[5:4]	Function	Note
0	Off (Bypass CABC)	-
0	UI mode (user interface image)	-
1	Still mode (still picture image)	-
1	Moving mode (Moving picture image)	Default

Note: When R82h[5:4]=00, CABC function is bypassed and PWM duty is fixed by R51h.

R51h:

No.	R/W	Address								Default setting value							
R51	R/W	A7	A6	A5	A4	A3	A2	A1	A0	D7	D6	D5	D4	D3	D2	D1	D0
	1/0	0	1	0	1	0	0	0	1	1	1	1	1	1	1	1	1

R51h [7:0]: Set PWM duty level when CABC Off (Bypass CABC mode)

R51h[7:0]								Function	Note
								PWM duty	
0	0	0	0	0	0	0	0	0%	-
0	0	0	0	0	0	0	1	0.3906%	-
0	0	0	0	0	0	1	0	0.7813%	-
:	:	:	:	:	:	:	:	:	-
1	1	1	1	1	1	0	1	98.8281%	-
1	1	1	1	1	1	1	0	99.2188%	-
1	1	1	1	1	1	1	1	100%	Default

53h:

No.	R/W	Address								Default setting value							
R53	R/W	A7	A6	A5	A4	A3	A2	A1	A0	D7	D6	D5	D4	D3	D2	D1	D0
	1/0	0	1	0	1	0	0	1	1	0	0	0	0	1	1	0	0

R53h [2]: BL, Back light is controlled by CABC function

R53h[2]	Function	Note
0	Off	-
1	On	Default

R53h [3]: ENDIM, Enable/Disable Dimming

R53h[3]	Function	Note
0	Disable	-
1	Enable	Default

R59h:

No.	R/W	Address								Default setting value							
R59	R/W	A7	A6	A5	A4	A3	A2	A1	A0	D7	D6	D5	D4	D3	D2	D1	D0
	1/0	0	1	0	1	1	0	0	1	0	0	0	0	0	0	0	0

R59h [2:0]: DRV_FRE_A, parameter A of adjusting PWM period

R59h[2:0]			Function	Note
0	0	0	1	Default
0	0	1	2	-
0	1	0	4	-
0	1	1	8	-
1	0	0	16	-
1	0	1	32	-
1	1	0	64	-
1	1	1	128	-

R5eh:

No.	R/W	Address								Default setting value							
R5e	R/W	A7	A6	A5	A4	A3	A2	A1	A0	D7	D6	D5	D4	D3	D2	D1	D0
	1/0	0	1	0	1	1	1	1	0	1	0	0	0	0	0	0	0

R5eh [7:0]: CAB_C_MB, Minimum duty constraint (minimum brightness)

R5eh[7:0]								Function	Note
								PWM duty	
0	0	0	0	0	0	0	0	0%	-
0	0	0	0	0	0	0	1	0.3906%	-
0	0	0	0	0	0	1	0	0.7813%	-
:	:	:	:	:	:	:	:	:	-
1	0	0	0	0	0	0	0	50%	Default
:	:	:	:	:	:	:	:	:	-
1	1	1	1	1	1	0	1	98.8281%	-
1	1	1	1	1	1	1	0	99.2188%	-
1	1	1	1	1	1	1	1	100%	-

R60h:

No.	R/W	Address								Default setting value							
R60	R/W	A7	A6	A5	A4	A3	A2	A1	A0	D7	D6	D5	D4	D3	D2	D1	D0
	1/0	0	1	1	0	0	0	0	0	0	0	0	0	0	1	0	0

R60h [7:0]: DRV_FRE_B, parameter B of adjusting PWM period

R60h[7:0]								Function	Note
								DRV_FRE_B	
0	0	0	0	0	0	0	0	0	-
0	0	0	0	0	0	0	1	1	-
0	0	0	0	0	0	1	0	2	-
0	0	0	0	0	0	1	1	3	-
0	0	0	0	0	1	0	0	4	Default
:	:	:	:	:	:	:	:	:	-
1	0	0	0	0	0	0	0	128	-
:	:	:	:	:	:	:	:	:	-
1	1	1	1	1	1	1	1	255	-

Backlight PWM output period = DCLK period x (DRV_FRE_A[2:0]) x 256 x (DRV_FRE_B[7:0]+1)

R65h:

No.	R/W	Address								Default setting value							
R65	R/W	A7	A6	A5	A4	A3	A2	A1	A0	D7	D6	D5	D4	D3	D2	D1	D0
	1/0	1	1	0	0	0	0	0	0	0	0	1	0	0	0	0	1

Total dimming time = DIMT_A x DIMT_B frame

R65h [5:4]: DIMT_A, total dimming time parameter A

R65h[5:4]	Function	Note
0	2	-
0	4	-
1	8	Default
1	16	-

R65h [1:0]: DIMT_B, total dimming time parameter B

R65h[1:0]	Function	Note
0	1	-
0	2	Default
1	3	-
1	4	-

Himax Confidential
Do Not Copy

R70h [7:0] ~ R78h [7:0]: DBG_0~DBG_8

No.	R/W	Address								Default setting value								
		A7	A6	A5	A4	A3	A2	A1	A0	D7	D6	D5	D4	D3	D2	D1	D0	Type
R70	1/0	0	1	1	1	0	0	0	0	1	1	0	0	1	0	0	0	UI
										0	0	0	1	0	0	0	0	Still
										0	1	1	1	0	0	0	0	Move
R71	1/0	0	1	1	1	0	0	0	1	1	1	0	1	0	1	1	0	UI
										0	1	1	0	0	0	0	0	Still
										1	0	1	0	1	1	0	0	Move
R72	1/0	0	1	1	1	0	0	1	0	1	1	1	0	0	0	0	0	UI
										1	0	0	1	0	0	0	0	Still
										1	1	0	0	0	0	0	0	Move
R73	1/0	0	1	1	1	0	0	1	1	1	1	1	0	1	0	0	0	UI
										1	0	1	1	1	0	1	0	Still
										1	1	0	0	1	1	0	1	Move
R74	1/0	0	1	1	1	1	0	0	0	1	1	1	1	0	0	0	0	UI
										1	1	0	0	1	1	0	1	Still
										1	1	0	1	0	1	1	0	Move
R75	1/0	0	1	1	1	1	0	0	1	1	1	1	1	0	1	0	0	UI
										1	1	0	1	1	1	0	0	Still
										1	1	1	0	0	0	0	0	Move
R76	1/0	0	1	1	1	0	1	1	0	1	1	1	1	1	0	0	0	UI
										1	1	1	0	0	1	1	0	Still
										1	1	1	0	1	1	0	0	Move
R77	1/0	0	1	1	1	0	1	1	1	1	1	1	1	1	1	0	0	UI
										1	1	1	1	0	0	1	0	Still
										1	1	1	1	1	0	0	0	Move
R78	1/0	0	1	1	1	1	0	0	0	1	1	1	1	1	1	1	1	UI
										1	1	1	1	1	1	1	1	Still
										1	1	1	1	1	1	1	1	Move

Duty cycle = (Register value / 255) x 100%

Register value = 255 x duty cycle

For example UI mode DBG0 duty cycle = 200/255 x 100% = 78.43 %

If DBG0 duty cycle need 51% the register value = 255 x 0.51 = 130 = 0x82

R70h~R78h will return default value when register R82h [5:4] CABAC mode selection is written.

8. 3-wire Serial Peripheral Interface (SPI)

The HX8264-D02 supports the 3-pin serial peripheral interface (SPI) to set internal register. The data is written to the register of assigned address when "End of transfer" is detected after the 17th SCL rising cycles.

Data is not accepted if there are less or more than 17 cycles for one transaction. Only when SCL is input 17 times and SCEN is in the "Low" period simultaneously, SDA is accepted.

The first bit means Read/Write command. "0" is WRITE. "1" is READ. And the next 8 bits (A7 ~ A0) specify the address of the register. And the last 8 bits are for Data setting (D7 ~ D0). The address and data are transferred from the MSB to LSB sequentially. And next cycle is turn-round cycle.

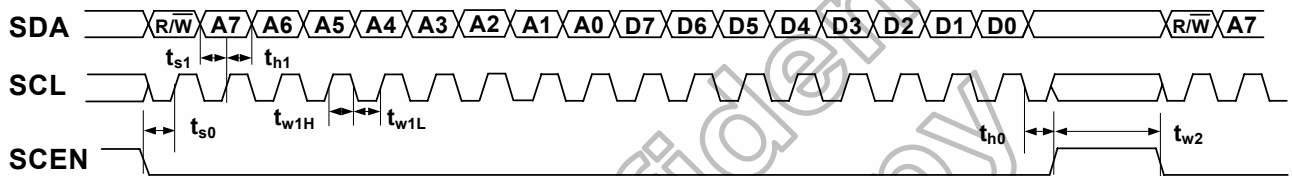

Figure 8.1 Serial Interface Signal Timing Chart

Item	Symbol	Conditions	Spec.			Unit
			Min.	Typ.	Max.	
SDA Setup Time	t_{s0}	SCEN to SCL	12	-	-	ns
	t_{s1}	SDA to SCL	12	-	-	ns
SDA Hold Time	t_{h0}	SCEN to SCL	12	-	-	ns
	t_{h1}	SDA to SCL	12	-	-	ns
Pulse Width	t_{w1L}	SCL low pulse width	50	-	-	ns
	t_{w1H}	SCL high pulse width	50	-	-	ns
	t_{w2}	SCEN high pulse width	50	-	-	ns
Clock duty	-	-	40	50	60	%

Table 8.1 Serial Interface timing parameter

9. Power on/off Sequence

To prevent the device damage from latch up, the power on/off sequence shown below must be followed.

Power ON: VDD, VSS → VDDA, VSSA → V1 to V14
 Power OFF: V1 to V14 → VDDA, VSSA → VDD, VSS

9.1 Power on/off control

HX8264-D02 has a power on/off sequence control function. In order to prevent IC from power on reset fail, the rising time (T_{POR}) of the digital power supply VDD should be maintained within the given specifications. Please refer to “AC Characteristics” for more detail on timing.

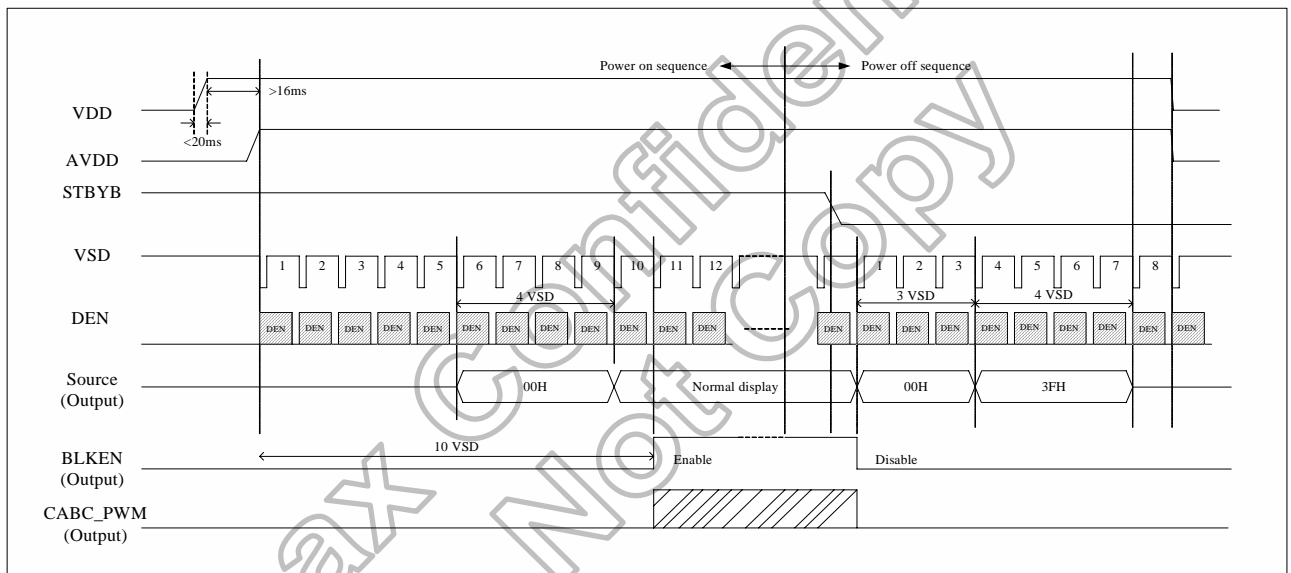

Figure 7. 1 Power on/off Timing Sequence

9.2 Enter and exit standby mode sequence

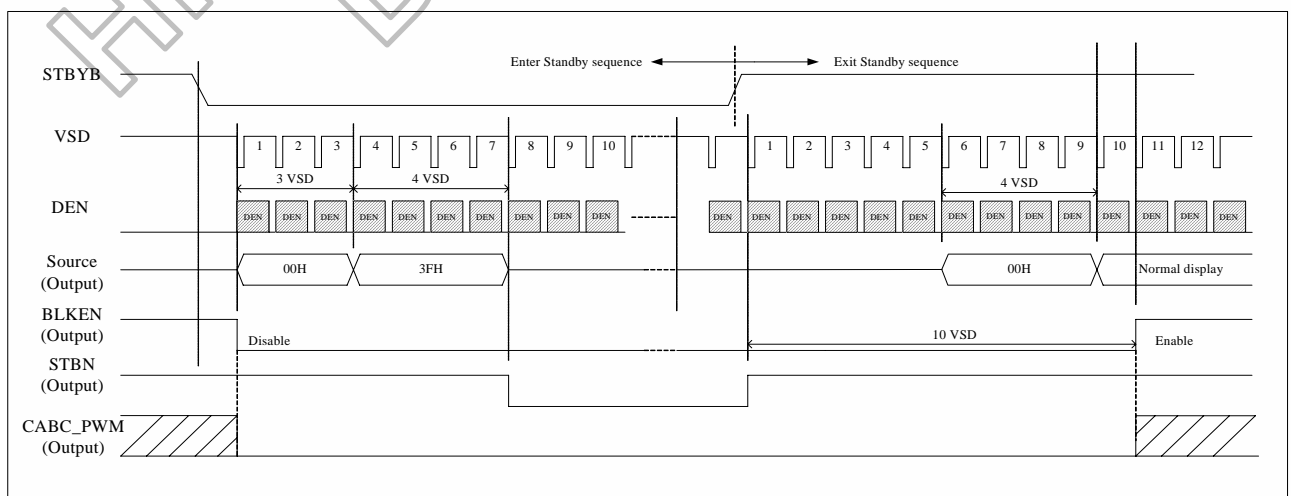

Figure 7. 2 Enter and Exit Standby Mode Sequence

10. DC Characteristics

10.1 Absolute maximum rating (VSS=0V)

Parameter	Symbol	Spec.			Unit
		Min.	Typ.	Max.	
Power supply voltage 1	VDD	-0.5	-	+5.0	V
Power supply voltage 2	VDDA	-0.5	-	+15	V
Logic Output Voltage	V _{OUT}	-0.5	-	+5.0	V
Input voltage	V _{in}	-0.5	-	VDDA+0.5	V
Operation temperature	T _{OPR}	-40	-	+85	°C
Storage temperature	T _{STG}	-55	-	+125	°C

Note: (1) All of the voltages listed above are with respective to VSS=0V.

(2) Device is subject to be damaged permanently if stresses beyond those absolute maximum ratings listed above.

10.2 DC electrical characteristics (VSS=0V, TA=25°C)

Parameter	Symbol	Spec.			Unit	Condition
		Min.	Typ.	Max.		
Power supply voltage	VDD	2.7	3.3	3.6	V	-
Power supply voltage	VDDA	6.5	-	13.5	V	-
Low level input voltage	V _{IL}	0	-	0.3VDD	V	For digital circuit
High level input voltage	V _{IH}	0.7VDD	-	VDD	V	For digital circuit
Output low voltage	V _{OL}	-	-	VSS+0.4	V	I _{OL} =400μA
Output high voltage	V _{OH}	VDD-0.4	-	-	V	I _{OH} =-400μA
Pull low/high resistance	R _i	200	250	300	kΩ	For the digital input pin @VDD=3.3V
Input leakage current	I _i	-	-	±1	μA	For digital circuit
Digital Operation current	I _{DD}	-	5	14	mA	Dual gate mode or Cascade mode slave, Fclk=50MHz, LD=48KHz, VDD=3.3V, CABC disable, No load
		-	7	16	mA	Cascade mode master, Fclk=50MHz, LD=48KHz, VDD=3.3V, CABC disable, No load
Digital stand-by current	I _{st1}	-	10	50	μA	Clock & all functions are stopped
Analog Operating current	I _{DDA}	-	6	8	mA	No load, Fclk=50MHz, FLD=48KHz @ VDDA=10V, V1=8V, V14=0.4V
Analog Stand-by current	I _{st2}	-	10	50	μA	No load, clock & all functions are stopped
Input level of V1~V7	V _{ref1}	0.4VDDA	-	VDDA-1	V	Gamma correction voltage input
Input level of V8~V14	V _{ref2}	0.1	-	0.6VDDA	V	Gamma correction voltage input
Output Voltage deviation	V _{od1}	-	±20	±35	mV	V _o =VSSA+0.1V~VSSA+0.5V & V _o =VDDA-0.5V~VDDA-0.1V
Output Voltage deviation	V _{od2}	-	±15	±20	mV	V _o =VSSA+0.5V~VDDA-0.5V
Output Voltage Offset between Chips	V _{oc}	-	-	±20	mV	V _o =VSSA+0.5V~VDDA-0.5V
Dynamic Range of Output	V _{dr}	0.1	-	VDDA-0.1	V	SO1~SO1200
Sinking Current of Outputs	I _{OLy}	80	-	-	μA	SO1~SO1200; V _o =0.1V vs. 1.0V, VDDA=13.5V
Driving Current of Outputs	I _{OHy}	80	-	-	μA	SO1~SO1200; V _o =0.1V vs. 12.5V, VDDA=13.5V
Resistance of Gamma Table	R _g	0.7*R _n	1.0*R _n	1.3*R _n	Ω	R _n : Internal gamma resistor

11. AC Characteristics

11.1 AC electrical characteristics

Parameter	Symbol	Spec.			Unit
		Min.	Typ.	Max.	
HS setup time	T_{hst}	8	-	-	ns
HS hold time	T_{hhd}	8	-	-	ns
VS setup time	T_{vst}	8	-	-	ns
VS hold time	T_{vhd}	8	-	-	ns
Data setup time	T_{dsu}	8	-	-	ns
Data hold time	T_{dhd}	8	-	-	ns
DE setup time	T_{esu}	8	-	-	ns
DE hold time	T_{ehd}	8	-	-	ns
VDD Power On Slew rate	T_{POR}	-	-	20	ms
RSTB pulse width	T_{Rst}	10	-	-	us
CLKIN cycle time	T_{cph}	20	-	-	ns
CLKIN pulse duty	T_{cwh}	40	50	60	%
Output stable time	T_{sst}	-	-	6	us

Himax Confidential
Do Not Copy

11.2 Data input format

- **Horizontal timing**

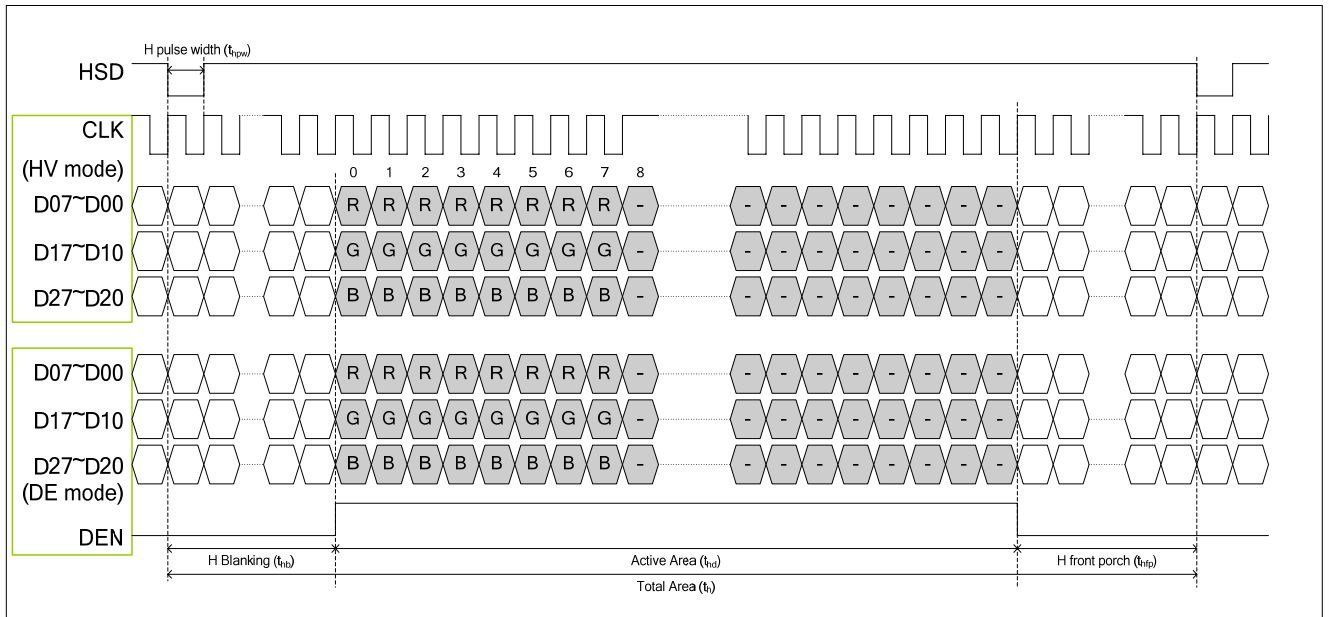

Figure 9. 1 Horizontal Input Timing Diagram

- **Vertical timing**

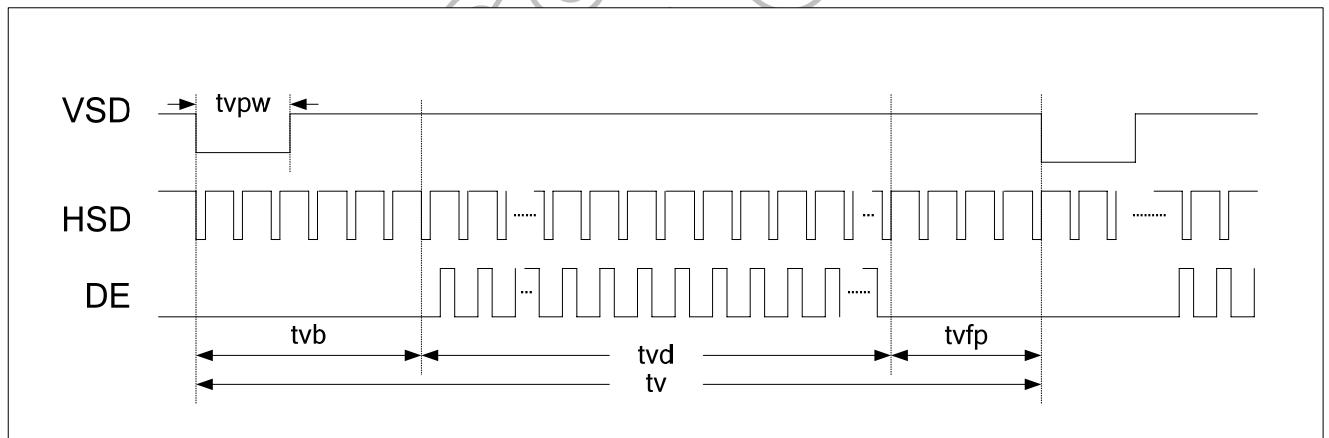

Figure 9. 2 Vertical Input Timing Diagram

11.2.1 Resolution : 800x480

- **Horizontal timing**

Parameter	Symbol	Spec.			Unit
		Min.	Typ.	Max.	
Horizontal Display Area	thd		800		DCLK
DCLK frequency	fclk	-	30	50	MHz
One Horizontal Line	th	889	928	1143	DCLK
HS pulse width	thpw	1	48	255	DCLK
HS Back Porch (Blanking)	thb		88		DCLK
HS Front Porch	thfp	1	40	255	DCLK
DE mode Blanking	th-thd	85	128	512	DCLK

- **Vertical timing**

Parameter	Symbol	Spec.			Unit
		Min.	Typ.	Max.	
Vertical Display Area	tdv		480		T _H
VS period time	tv	513	525	767	T _H
VS pulse width	tvpw	3	3	255	T _H
VS Back Porch (Blanking)	tvb		32		T _H
VS Front Porch	tvfp	1	13	255	T _H
DE mode Blanking	tv-tvd	4	45	255	T _H

11.2.2 Resolution : 800x600

● **Horizontal timing**

Parameter	Symbol	Spec.			Unit
		Min.	Typ.	Max.	
Horizontal Display Area	thd		800		DCLK
DCLK frequency	fclk	-	40	50	MHz
One Horizontal Line	th	889	1000	1143	DCLK
HS pulse width	thpw	1	48	255	DCLK
HS Back Porch (Blanking)	thb		88		DCLK
HS Front Porch	thfp	1	112	255	DCLK
DE mode Blanking	th-thd	85	200	512	DCLK

● **Vertical timing**

Parameter	Symbol	Spec.			Unit
		Min.	Typ.	Max.	
Vertical Display Area	tdv		600		T _H
VS period time	tv	640	660	943	T _H
VS pulse width	tvpw	3	3	255	T _H
VS Back Porch (Blanking)	tvb		39		T _H
VS Front Porch	tvfp	1	21	255	T _H
DE mode Blanking	tv-tvd	4	60	255	T _H

11.2.3 Resolution : 640x480

● **Horizontal timing**

Parameter	Symbol	Spec.			Unit
		Min.	Typ.	Max.	
Horizontal Display Area	thd		640		DCLK
DCLK frequency	fclk	-	24	50	MHz
One Horizontal Line	th		760		DCLK
HS pulse width	thpw	1	48	255	DCLK
HS Back Porch (Blanking)	thb		88		DCLK
HS Front Porch	thfp	1	32	255	DCLK
DE mode Blanking	th-thd	85	120	512	DCLK

● **Vertical timing**

Parameter	Symbol	Spec.			Unit
		Min.	Typ.	Max.	
Vertical Display Area	tvd		480		T _H
VS period time	tv	513	525	767	T _H
VS pulse width	tvpw	3	3	255	T _H
VS Back Porch (Blanking)	tvb		32		T _H
VS Front Porch	tvfp	1	13	255	T _H
DE mode Blanking	tv-tvd	4	45	255	T _H

11.2.4 Resolution : 400x240

● **Horizontal timing**

Parameter	Symbol	Spec.			Unit
		Min.	Typ.	Max.	
Horizontal Display Area	thd		400		DCLK
DCLK frequency	fclk	-	8.4	50	MHz
One Horizontal Line	th	489	520	743	DCLK
HS pulse width	thpw	1	1	255	DCLK
HS Back Porch	thb		88		DCLK
HS Front Porch	thfp	1	32	255	DCLK
DE mode Blanking	th-thd	85	120	512	DCLK

● **Vertical timing**

Parameter	Symbol	Spec.			Unit
		Min.	Typ.	Max.	
Vertical Display Area	tdv		240		T _H
VS period time	tv	258	270	512	T _H
VS pulse width	tvpw	1	1	255	T _H
VS Back Porch	tvb		17		T _H
VS Front Porch	tvfp	1	13	255	T _H
DE mode Blanking	tv-tvd	4	30	255	T _H

12. Waveform

12.1 Timing waveform table

12.1.1 Parallel 24-bit RGB mode

Parameter	Symbol	Min.	Typ.	Max.	Unit	Conditions
CLKIN Frequency	Fclk	-	40	50	MHz	VDD=3.0V~3.6V
CLKIN Cycle Time	Tclk	20	25	-	ns	-
CLKIN Pulse Duty	Tcwh	40	50	60	%	Tclk
Time from HSD to Source Output	Thso	64			CLKIN	-
Time from HSD to LD	Thld	64			CLKIN	-
Time from HSD to STV	Thstv	2			CLKIN	-
Time from HSD to CKV	Thckv	20			CLKIN	-
Time from HSD to OEV	Thoev	4			CLKIN	-
LD Pulse Width	Twld	10			CLKIN	-
CKV Pulse Width	Twckv	66			CLKIN	-
OEV Pulse Width	Twoev	74			CLKIN	-

Table 10. 1 Parallel 24-bit RGB mode

Himax Confidential
Do Not Copy

12.2 Timing diagram

12.2.1 Input clock and data timing waveform

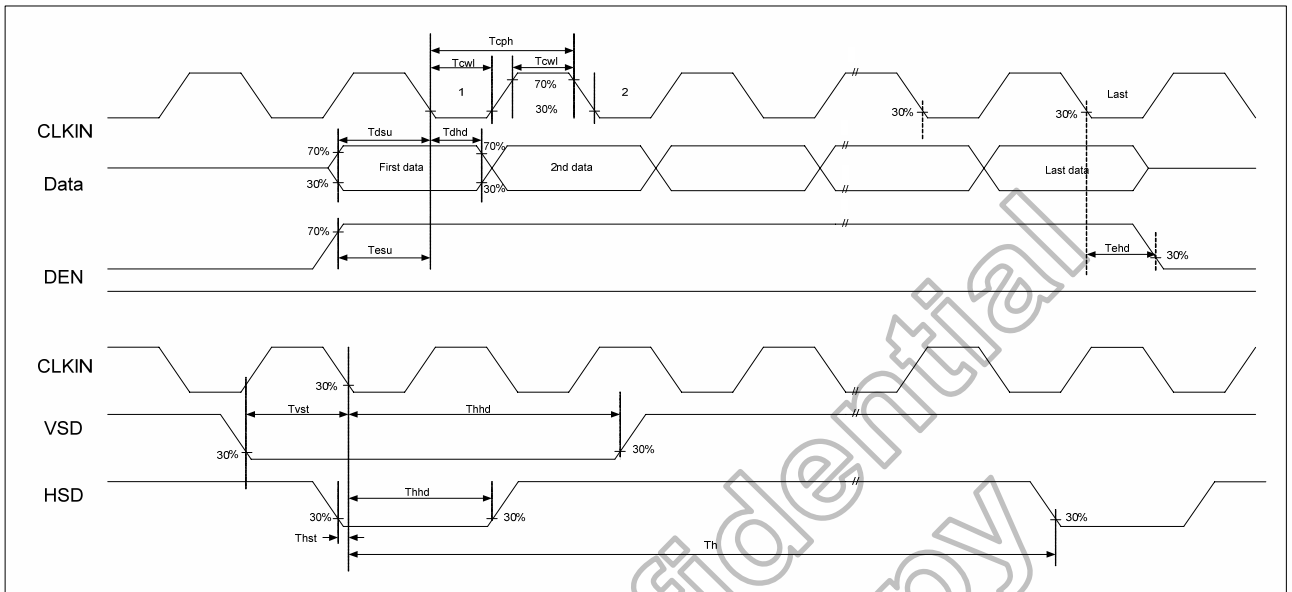

Figure 10. 1 Input Clock and Data Timing Diagram

12.2.2 Source output timing waveform (Cascade)

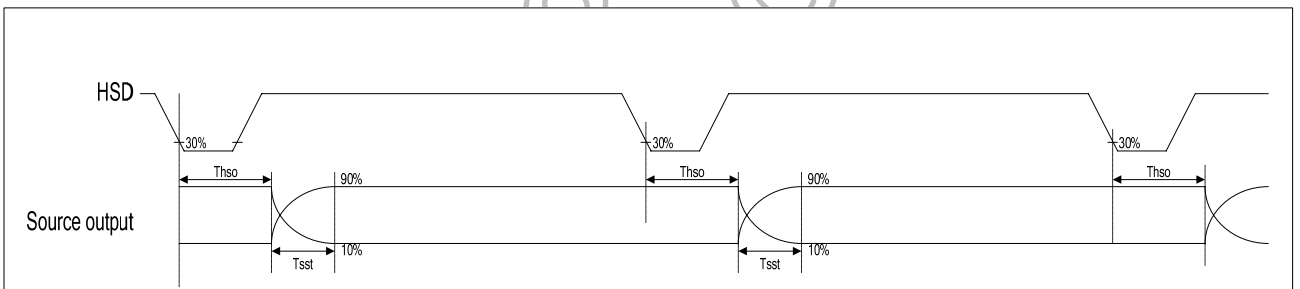

Figure 10. 2 Source Output Timing Diagram

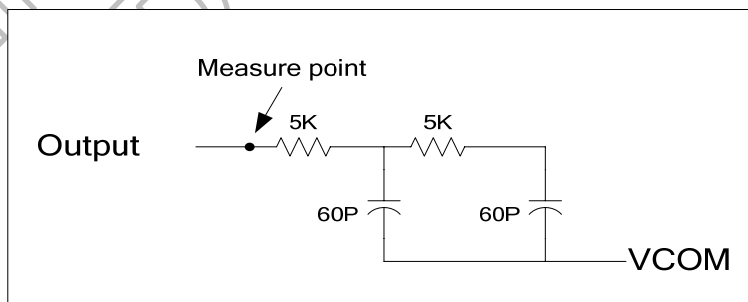

Figure 10. 3 Output Load Condition

12.2.3 Vertical timing diagram HV (Cascade)

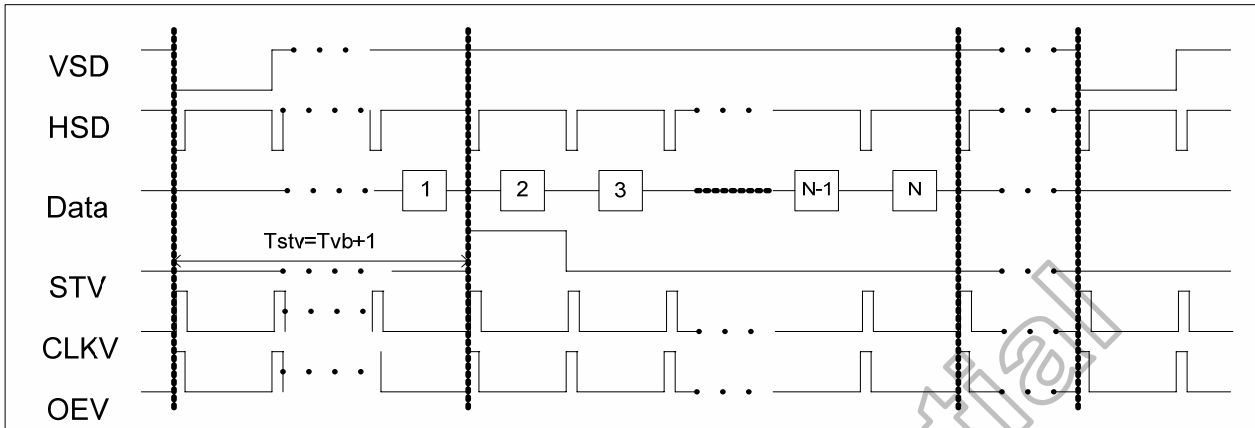

Figure 10. 4 Vertical Timing Diagram HV (Cascade)

12.2.4 Vertical timing diagram DE (Cascade)

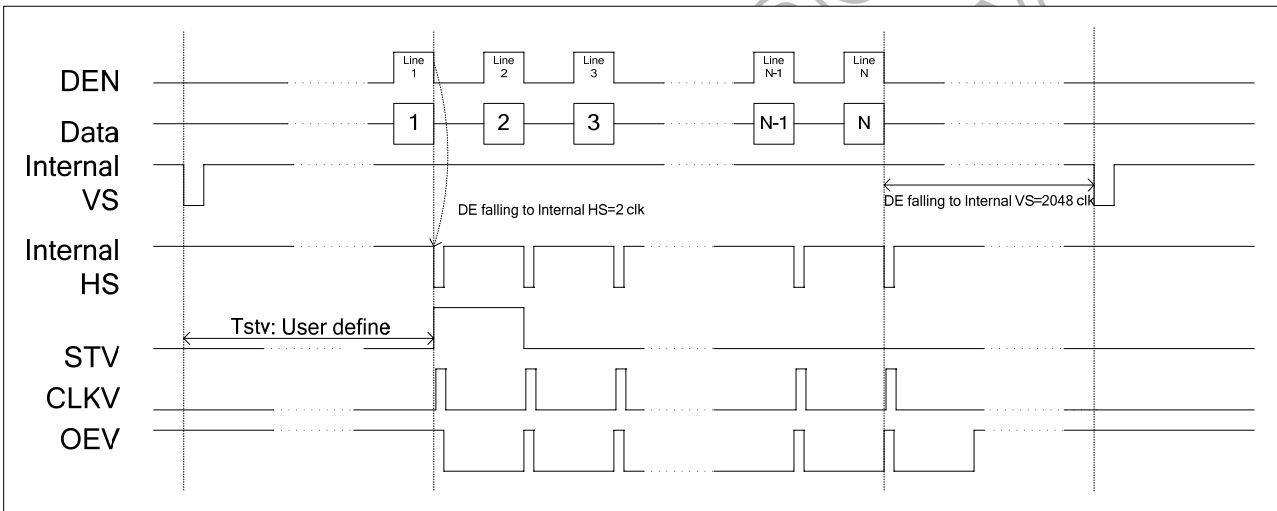

Figure 10. 5 Vertical Timing Diagram DE (Cascade)

12.2.5 Gate output timing diagram (Cascade)

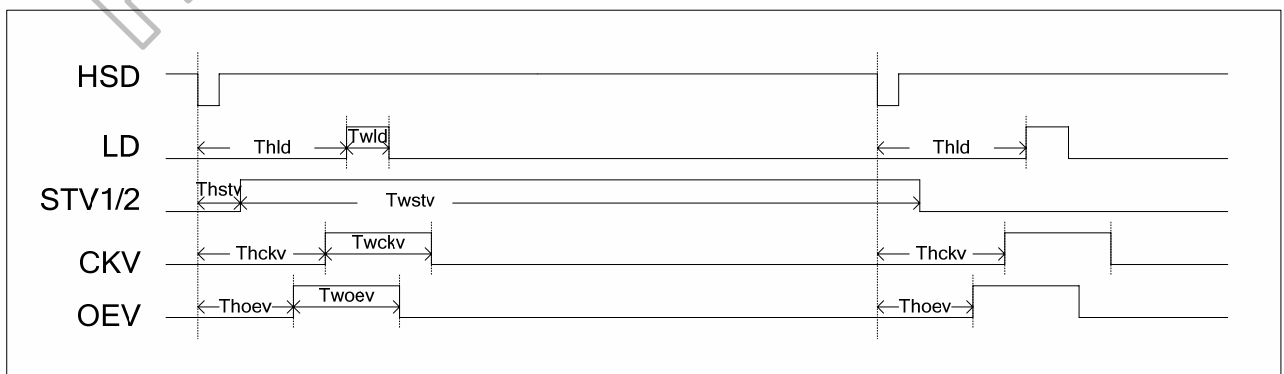

Figure 10. 6 Gate Output Timing Diagram (Cascade)

12.2.6 Vertical timing diagram HV (Dual gate)

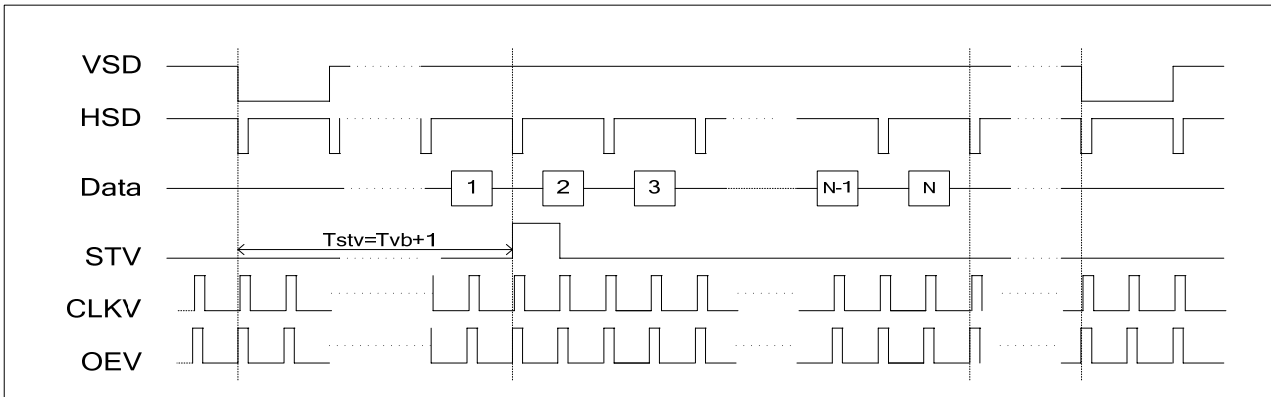

Figure 10. 7 Vertical Timing Diagram HV (Dual Gate)

12.2.7 Vertical timing diagram DE (Dual gate)

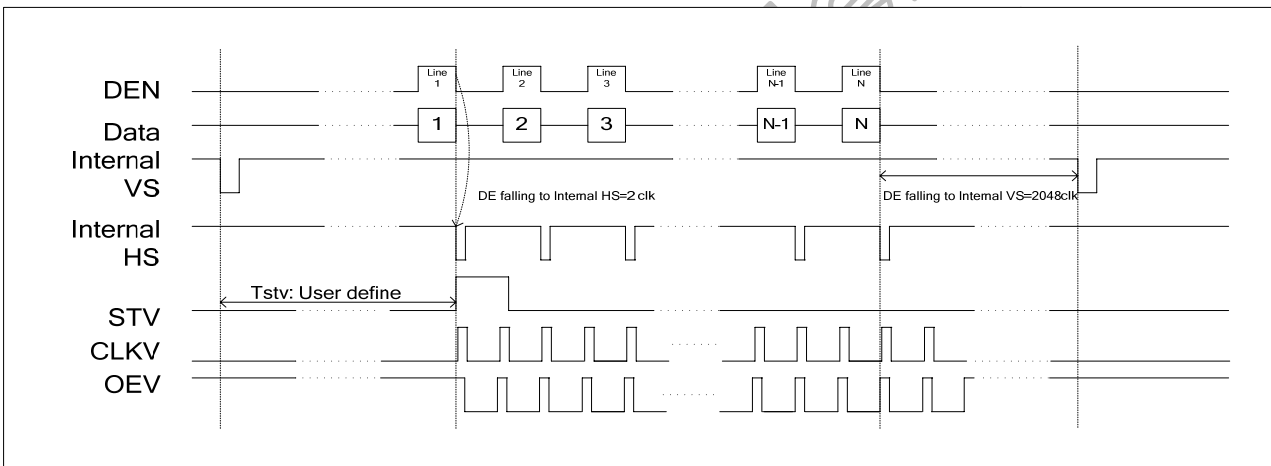

Figure 10. 8 Vertical Timing Diagram DE (Dual Gate)

12.2.8 Gate output timing diagram (Dual gate)

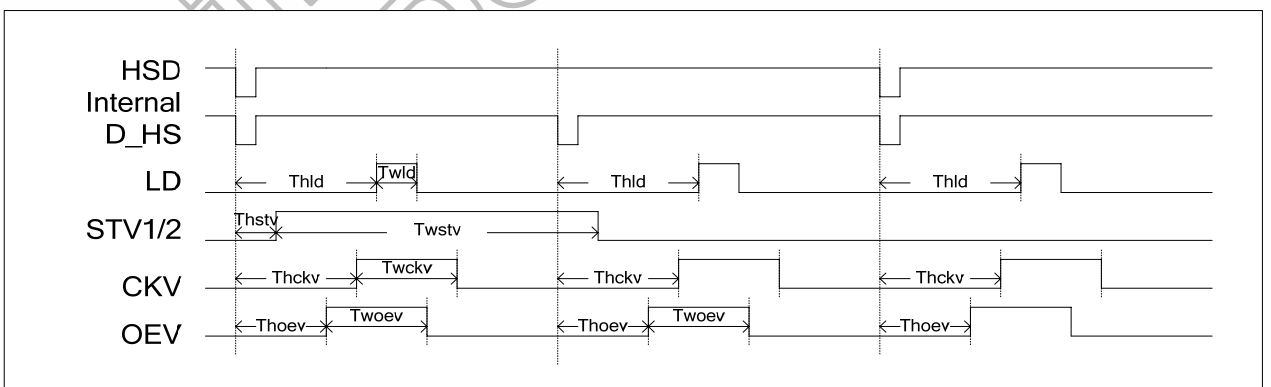

Figure 10. 9 Gate Output Timing Diagram (Dual Gate)

13. Pin Assignment (IC Face View)

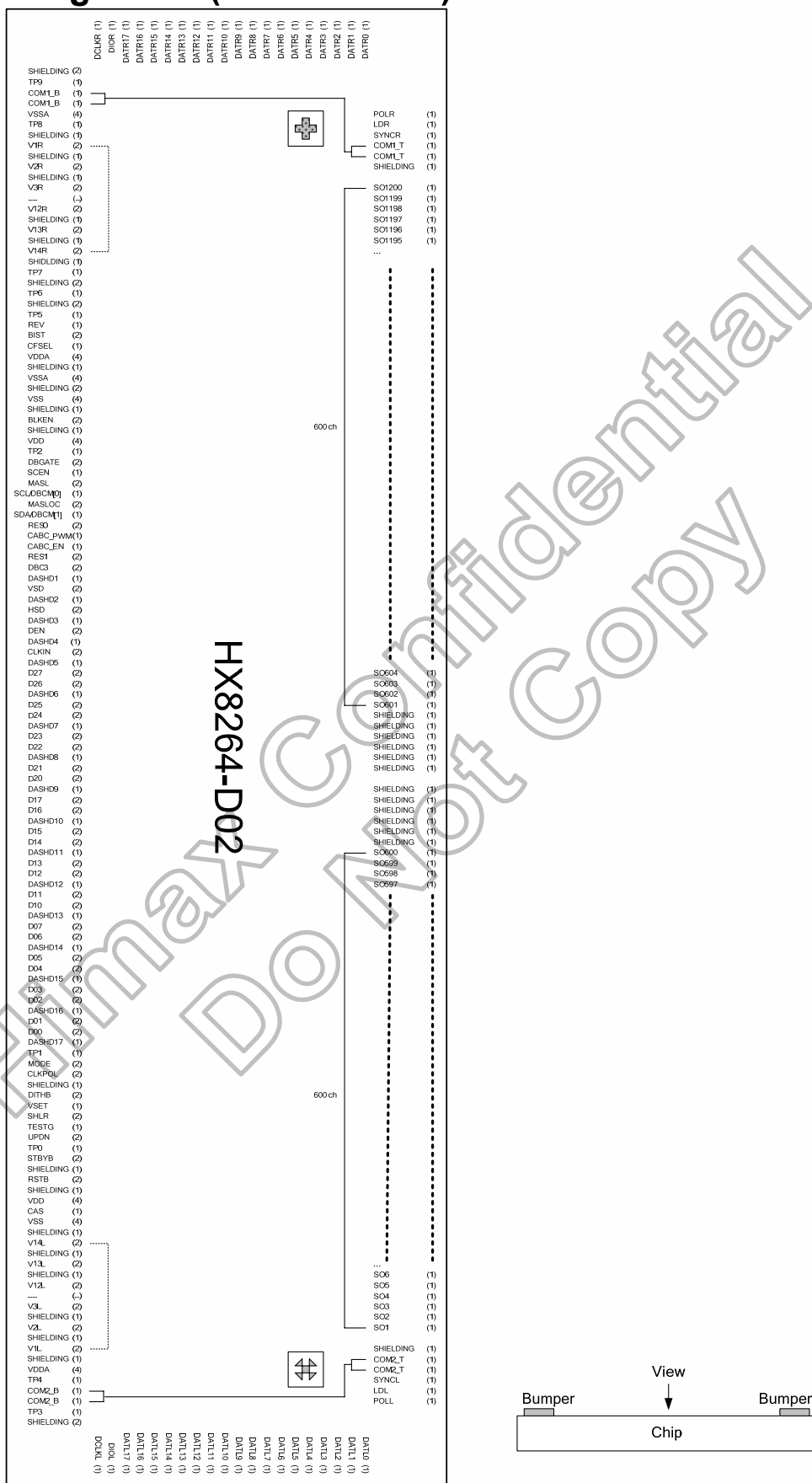

Figure 11. 1 Pin Assignment

14. Package Outline

Chip size: 22578μm x 944μm (including seal ring and scribe line)

Bump height: 15μm±3μm

Bump hardness: 60 H_v±15 H_v

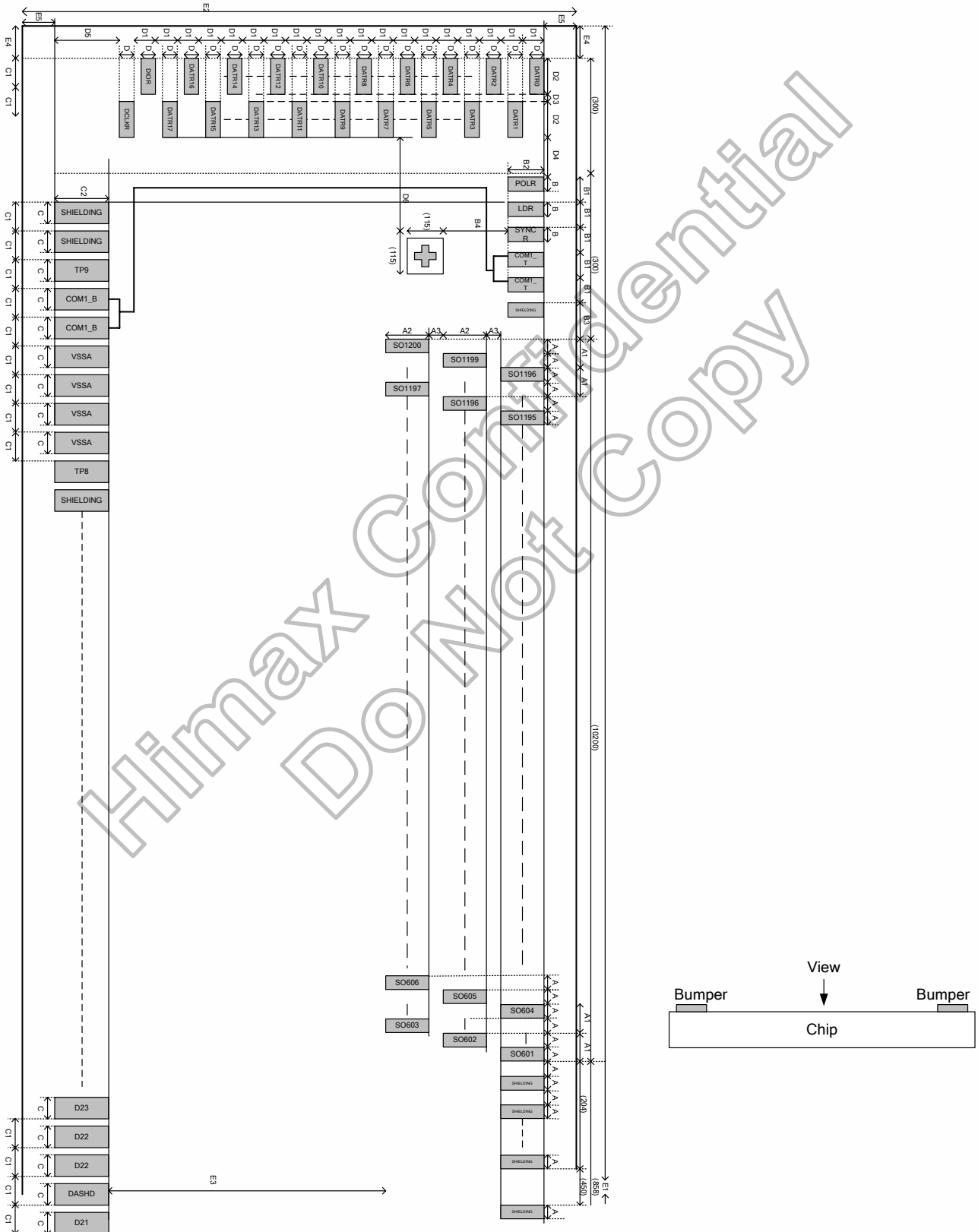

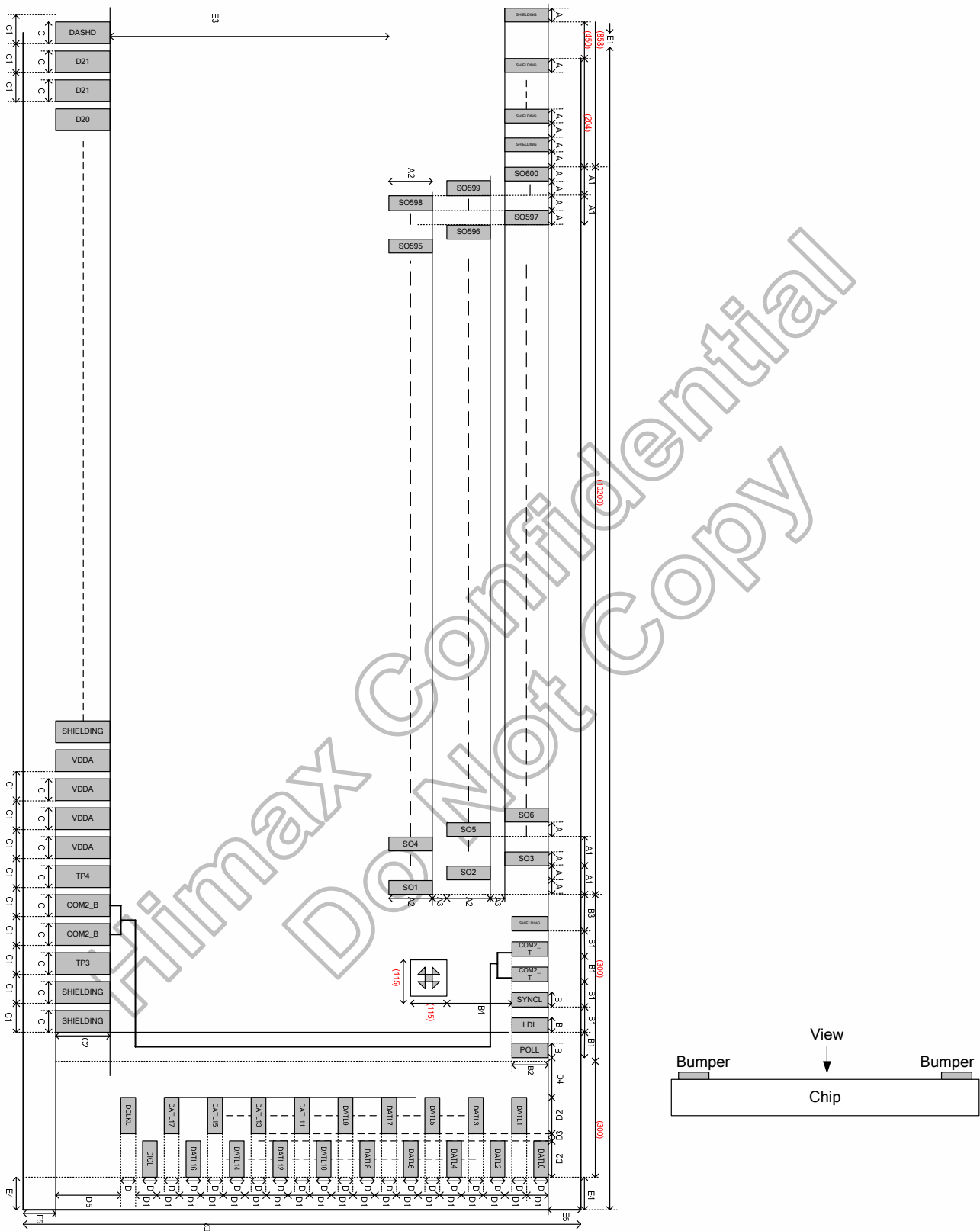

Figure 12. 1 Package Outline

Alignment mark

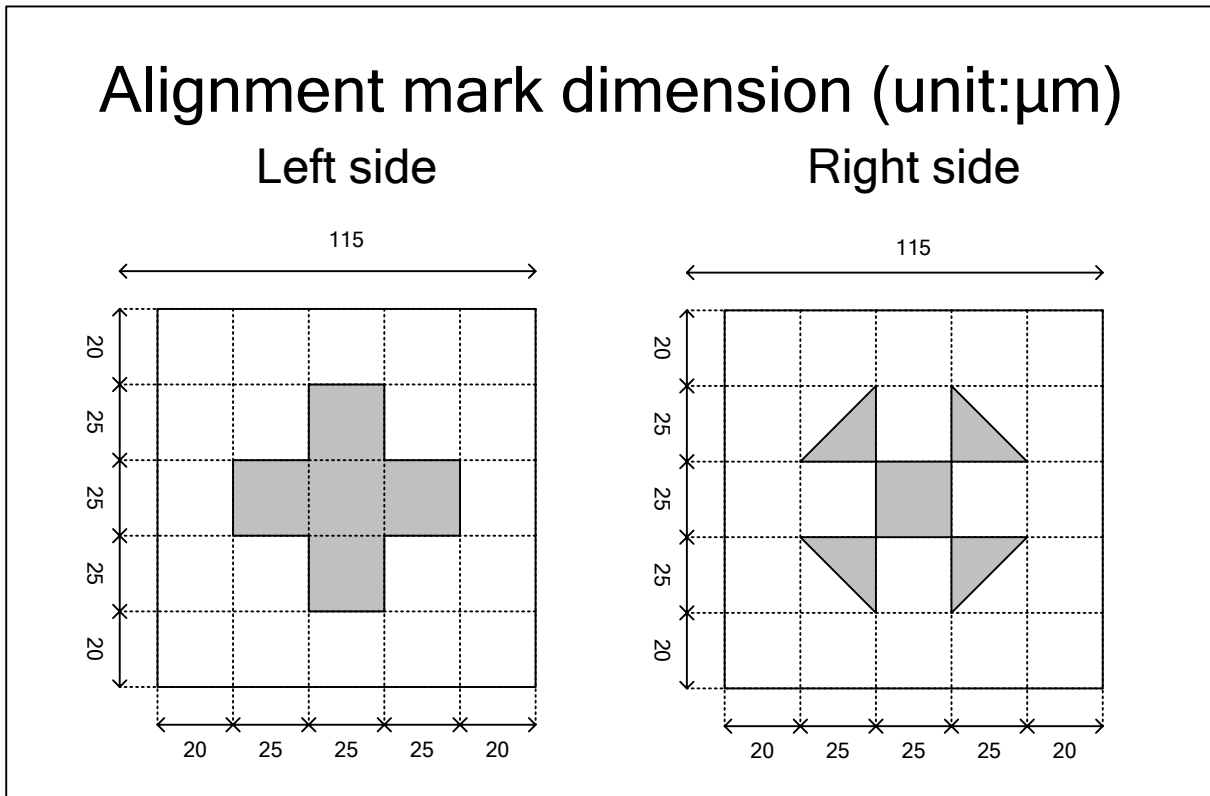

Figure 12. 2 Alignment Mark

Pad information

Symbol	Dimension (um)
A	17
A1	34
A2	110
A3	30
B	30
B1	50
B2	70
B3	50
B4	191.5
C	65
C1	85
C2	110

Symbol	Dimension (um)
D	30
D1	40
D2	100
D3	30
D4	70
D5	34
D6	168.5
E1	22578
E2	944
E3	324
E4	60
E5	60

Table 12. 1 Pad Information

14.1 Pad coordinates

No.	Name	X	Y
1	SHIELDING	-10922.5	-357
2	SHIELDING	-10837.5	-357
3	TP9	-10752.5	-357
4	COM1_B	-10667.5	-357
5	COM1_B	-10582.5	-357
6	VSSA	-10497.5	-357
7	VSSA	-10412.5	-357
8	VSSA	-10327.5	-357
9	VSSA	-10242.5	-357
10	TP8	-10157.5	-357
11	SHIELDING	-10072.5	-357
12	V1R	-9987.5	-357
13	V1R	-9902.5	-357
14	SHIELDING	-9817.5	-357
15	V2R	-9732.5	-357
16	V2R	-9647.5	-357
17	SHIELDING	-9562.5	-357
18	V3R	-9477.5	-357
19	V3R	-9392.5	-357
20	SHIELDING	-9307.5	-357
21	V4R	-9222.5	-357
22	V4R	-9137.5	-357
23	SHIELDING	-9052.5	-357
24	V5R	-8967.5	-357
25	V5R	-8882.5	-357
26	SHIELDING	-8797.5	-357
27	V6R	-8712.5	-357
28	V6R	-8627.5	-357
29	SHIELDING	-8542.5	-357
30	V7R	-8457.5	-357
31	V7R	-8372.5	-357
32	SHIELDING	-8287.5	-357
33	V8R	-8202.5	-357
34	V8R	-8117.5	-357
35	SHIELDING	-8032.5	-357
36	V9R	-7947.5	-357
37	V9R	-7862.5	-357
38	SHIELDING	-7777.5	-357
39	V10R	-7692.5	-357
40	V10R	-7607.5	-357
41	SHIELDING	-7522.5	-357
42	V11R	-7437.5	-357
43	V11R	-7352.5	-357
44	SHIELDING	-7267.5	-357
45	V12R	-7182.5	-357
46	V12R	-7097.5	-357
47	SHIELDING	-7012.5	-357
48	V13R	-6927.5	-357
49	V13R	-6842.5	-357
50	SHIELDING	-6757.5	-357

No.	Name	X	Y
51	V14R	-6672.5	-357
52	V14R	-6587.5	-357
53	SHIELDING	-6502.5	-357
54	TP7	-6417.5	-357
55	SHIELDING	-6332.5	-357
56	TP6	-6247.5	-357
57	SHIELDING	-6162.5	-357
58	TP5	-6077.5	-357
59	REV	-5992.5	-357
60	BIST	-5907.5	-357
61	BIST	-5822.5	-357
62	CFSEL	-5737.5	-357
63	VDDA	-5652.5	-357
64	VDDA	-5567.5	-357
65	VDDA	-5482.5	-357
66	VDDA	-5397.5	-357
67	SHIELDING	-5312.5	-357
68	VSSA	-5227.5	-357
69	VSSA	-5142.5	-357
70	VSSA	-5057.5	-357
71	VSSA	-4972.5	-357
72	SHIELDING	-4887.5	-357
73	VSS	-4802.5	-357
74	VSS	-4717.5	-357
75	VSS	-4632.5	-357
76	VSS	-4547.5	-357
77	SHIELDING	-4462.5	-357
78	BLKEN	-4377.5	-357
79	BLKEN	-4292.5	-357
80	SHIELDING	-4207.5	-357
81	VDD	-4122.5	-357
82	VDD	-4037.5	-357
83	VDD	-3952.5	-357
84	VDD	-3867.5	-357
85	TP2	-3782.5	-357
86	DBGATE	-3697.5	-357
87	DBGATE	-3612.5	-357
88	SCEN	-3527.5	-357
89	MASL	-3442.5	-357
90	MASL	-3357.5	-357
91	SCL/DCM[0]	-3272.5	-357
92	MASLOC	-3187.5	-357
93	MASLOC	-3102.5	-357
94	SDA/DCM[1]	-3017.5	-357
95	RES0	-2932.5	-357
96	RES0	-2847.5	-357
97	CABC_PWM	-2762.5	-357
98	CABC_EN	-2677.5	-357
99	RES1	-2592.5	-357
100	RES1	-2507.5	-357

No.	Name	X	Y
101	DBC3	-2422.5	-357
102	DBC3	-2337.5	-357
103	DASHD1	-2252.5	-357
104	VSD	-2167.5	-357
105	VSD	-2082.5	-357
106	DASHD2	-1997.5	-357
107	HSD	-1912.5	-357
108	HSD	-1827.5	-357
109	DASHD3	-1742.5	-357
110	DEN	-1657.5	-357
111	DEN	-1572.5	-357
112	DASHD4	-1487.5	-357
113	CLKIN	-1402.5	-357
114	CLKIN	-1317.5	-357
115	DASHD5	-1232.5	-357
116	D27	-1147.5	-357
117	D27	-1062.5	-357
118	D26	-977.5	-357
119	D26	-892.5	-357
120	DASHD6	-807.5	-357
121	D25	-722.5	-357
122	D25	-637.5	-357
123	D24	-552.5	-357
124	D24	-467.5	-357
125	DASHD7	-382.5	-357
126	D23	-297.5	-357
127	D23	-212.5	-357
128	D22	-127.5	-357
129	D22	-42.5	-357
130	DASHD8	42.5	-357
131	D21	127.5	-357
132	D21	212.5	-357
133	D20	297.5	-357
134	D20	382.5	-357
135	DASHD9	467.5	-357
136	D17	552.5	-357
137	D17	637.5	-357
138	D16	722.5	-357
139	D16	807.5	-357
140	DASHD10	892.5	-357
141	D15	977.5	-357
142	D15	1062.5	-357
143	D14	1147.5	-357
144	D14	1232.5	-357
145	DASHD11	1317.5	-357
146	D13	1402.5	-357
147	D13	1487.5	-357
148	D12	1572.5	-357
149	D12	1657.5	-357
150	DASHD12	1742.5	-357

No.	Name	X	Y
151	D11	1827.5	-357
152	D11	1912.5	-357
153	D10	1997.5	-357
154	D10	2082.5	-357
155	DASHD13	2167.5	-357
156	D07	2252.5	-357
157	D07	2337.5	-357
158	D06	2422.5	-357
159	D06	2507.5	-357
160	DASHD14	2592.5	-357
161	D05	2677.5	-357
162	D05	2762.5	-357
163	D04	2847.5	-357
164	D04	2932.5	-357
165	DASHD15	3017.5	-357
166	D03	3102.5	-357
167	D03	3187.5	-357
168	D02	3272.5	-357
169	D02	3357.5	-357
170	DASHD16	3442.5	-357
171	D01	3527.5	-357
172	D01	3612.5	-357
173	D00	3697.5	-357
174	D00	3782.5	-357
175	DASHD17	3867.5	-357
176	TP1	3952.5	-357
177	MODE	4037.5	-357
178	MODE	4122.5	-357
179	CLKPOL	4207.5	-357
180	CLKPOL	4292.5	-357
181	SHIELDING	4377.5	-357
182	DITHB	4462.5	-357
183	DITHB	4547.5	-357
184	VSET	4632.5	-357
185	SHLR	4717.5	-357
186	SHLR	4802.5	-357
187	TESTG	4887.5	-357
188	UPDN	4972.5	-357
189	UPDN	5057.5	-357
190	TP0	5142.5	-357
191	STBYB	5227.5	-357
192	STBYB	5312.5	-357
193	SHIELDING	5397.5	-357
194	RSTB	5482.5	-357
195	RSTB	5567.5	-357
196	SHIELDING	5652.5	-357
197	VDD	5737.5	-357
198	VDD	5822.5	-357
199	VDD	5907.5	-357
200	VDD	5992.5	-357

No.	Name	X	Y
201	CAS	6077.5	-357
202	VSS	6162.5	-357
203	VSS	6247.5	-357
204	VSS	6332.5	-357
205	VSS	6417.5	-357
206	SHIELDING	6502.5	-357
207	V14L	6587.5	-357
208	V14L	6672.5	-357
209	SHIELDING	6757.5	-357
210	V13L	6842.5	-357
211	V13L	6927.5	-357
212	SHIELDING	7012.5	-357
213	V12L	7097.5	-357
214	V12L	7182.5	-357
215	SHIELDING	7267.5	-357
216	V11L	7352.5	-357
217	V11L	7437.5	-357
218	SHIELDING	7522.5	-357
219	V10L	7607.5	-357
220	V10L	7692.5	-357
221	SHIELDING	7777.5	-357
222	V9L	7862.5	-357
223	V9L	7947.5	-357
224	SHIELDING	8032.5	-357
225	V8L	8117.5	-357
226	V8L	8202.5	-357
227	SHIELDING	8287.5	-357
228	V7L	8372.5	-357
229	V7L	8457.5	-357
230	SHIELDING	8542.5	-357
231	V6L	8627.5	-357
232	V6L	8712.5	-357
233	SHIELDING	8797.5	-357
234	V5L	8882.5	-357
235	V5L	8967.5	-357
236	SHIELDING	9052.5	-357
237	V4L	9137.5	-357
238	V4L	9222.5	-357
239	SHIELDING	9307.5	-357
240	V3L	9392.5	-357
241	V3L	9477.5	-357
242	SHIELDING	9562.5	-357
243	V2L	9647.5	-357
244	V2L	9732.5	-357
245	SHIELDING	9817.5	-357
246	V1L	9902.5	-357
247	V1L	9987.5	-357
248	SHIELDING	10072.5	-357
249	VDDA	10157.5	-357
250	VDDA	10242.5	-357

No.	Name	X	Y
251	VDDA	10327.5	-357
252	VDDA	10412.5	-357
253	TP4	10497.5	-357
254	COM2_B	10582.5	-357
255	COM2_B	10667.5	-357
256	TP3	10752.5	-357
257	SHIELDING	10837.5	-357
258	SHIELDING	10922.5	-357
259	DCLKL	11049	-363
260	DIOL	11179	-323
261	DATL17	11049	-283
262	DATL16	11179	-243
263	DATL15	11049	-203
264	DATL14	11179	-163
265	DATL13	11049	-123
266	DATL12	11179	-83
267	DATL11	11049	-43
268	DATL10	11179	-3
269	DATL9	11049	37
270	DATL8	11179	77
271	DATL7	11049	117
272	DATL6	11179	157
273	DATL5	11049	197
274	DATL4	11179	237
275	DATL3	11049	277
276	DATL2	11179	317
277	DATL1	11049	357
278	DATL0	11179	397
279	POLL	10914	377
280	LDL	10864	377
281	SYNCL	10814	377
282	COM2_T	10764	377
283	COM2_T	10714	377
284	SHIELDING	10664	377
285	SO1	10620.5	77
286	SO2	10603.5	217
287	SO3	10586.5	357
288	SO4	10569.5	77
289	SO5	10552.5	217
290	SO6	10535.5	357
291	SO7	10518.5	77
292	SO8	10501.5	217
293	SO9	10484.5	357
294	SO10	10467.5	77
295	SO11	10450.5	217
296	SO12	10433.5	357
297	SO13	10416.5	77
298	SO14	10399.5	217
299	SO15	10382.5	357
300	SO16	10365.5	77

No.	Name	X	Y
301	SO17	10348.5	217
302	SO18	10331.5	357
303	SO19	10314.5	77
304	SO20	10297.5	217
305	SO21	10280.5	357
306	SO22	10263.5	77
307	SO23	10246.5	217
308	SO24	10229.5	357
309	SO25	10212.5	77
310	SO26	10195.5	217
311	SO27	10178.5	357
312	SO28	10161.5	77
313	SO29	10144.5	217
314	SO30	10127.5	357
315	SO31	10110.5	77
316	SO32	10093.5	217
317	SO33	10076.5	357
318	SO34	10059.5	77
319	SO35	10042.5	217
320	SO36	10025.5	357
321	SO37	10008.5	77
322	SO38	9991.5	217
323	SO39	9974.5	357
324	SO40	9957.5	77
325	SO41	9940.5	217
326	SO42	9923.5	357
327	SO43	9906.5	77
328	SO44	9889.5	217
329	SO45	9872.5	357
330	SO46	9855.5	77
331	SO47	9838.5	217
332	SO48	9821.5	357
333	SO49	9804.5	77
334	SO50	9787.5	217
335	SO51	9770.5	357
336	SO52	9753.5	77
337	SO53	9736.5	217
338	SO54	9719.5	357
339	SO55	9702.5	77
340	SO56	9685.5	217
341	SO57	9668.5	357
342	SO58	9651.5	77
343	SO59	9634.5	217
344	SO60	9617.5	357
345	SO61	9600.5	77
346	SO62	9583.5	217
347	SO63	9566.5	357
348	SO64	9549.5	77
349	SO65	9532.5	217
350	SO66	9515.5	357

No.	Name	X	Y
351	SO67	9498.5	77
352	SO68	9481.5	217
353	SO69	9464.5	357
354	SO70	9447.5	77
355	SO71	9430.5	217
356	SO72	9413.5	357
357	SO73	9396.5	77
358	SO74	9379.5	217
359	SO75	9362.5	357
360	SO76	9345.5	77
361	SO77	9328.5	217
362	SO78	9311.5	357
363	SO79	9294.5	77
364	SO80	9277.5	217
365	SO81	9260.5	357
366	SO82	9243.5	77
367	SO83	9226.5	217
368	SO84	9209.5	357
369	SO85	9192.5	77
370	SO86	9175.5	217
371	SO87	9158.5	357
372	SO88	9141.5	77
373	SO89	9124.5	217
374	SO90	9107.5	357
375	SO91	9090.5	77
376	SO92	9073.5	217
377	SO93	9056.5	357
378	SO94	9039.5	77
379	SO95	9022.5	217
380	SO96	9005.5	357
381	SO97	8988.5	77
382	SO98	8971.5	217
383	SO99	8954.5	357
384	SO100	8937.5	77
385	SO101	8920.5	217
386	SO102	8903.5	357
387	SO103	8886.5	77
388	SO104	8869.5	217
389	SO105	8852.5	357
390	SO106	8835.5	77
391	SO107	8818.5	217
392	SO108	8801.5	357
393	SO109	8784.5	77
394	SO110	8767.5	217
395	SO111	8750.5	357
396	SO112	8733.5	77
397	SO113	8716.5	217
398	SO114	8699.5	357
399	SO115	8682.5	77
400	SO116	8665.5	217

No.	Name	X	Y
401	SO117	8648.5	357
402	SO118	8631.5	77
403	SO119	8614.5	217
404	SO120	8597.5	357
405	SO121	8580.5	77
406	SO122	8563.5	217
407	SO123	8546.5	357
408	SO124	8529.5	77
409	SO125	8512.5	217
410	SO126	8495.5	357
411	SO127	8478.5	77
412	SO128	8461.5	217
413	SO129	8444.5	357
414	SO130	8427.5	77
415	SO131	8410.5	217
416	SO132	8393.5	357
417	SO133	8376.5	77
418	SO134	8359.5	217
419	SO135	8342.5	357
420	SO136	8325.5	77
421	SO137	8308.5	217
422	SO138	8291.5	357
423	SO139	8274.5	77
424	SO140	8257.5	217
425	SO141	8240.5	357
426	SO142	8223.5	77
427	SO143	8206.5	217
428	SO144	8189.5	357
429	SO145	8172.5	77
430	SO146	8155.5	217
431	SO147	8138.5	357
432	SO148	8121.5	77
433	SO149	8104.5	217
434	SO150	8087.5	357
435	SO151	8070.5	77
436	SO152	8053.5	217
437	SO153	8036.5	357
438	SO154	8019.5	77
439	SO155	8002.5	217
440	SO156	7985.5	357
441	SO157	7968.5	77
442	SO158	7951.5	217
443	SO159	7934.5	357
444	SO160	7917.5	77
445	SO161	7900.5	217
446	SO162	7883.5	357
447	SO163	7866.5	77
448	SO164	7849.5	217
449	SO165	7832.5	357
450	SO166	7815.5	77

No.	Name	X	Y
451	SO167	7798.5	217
452	SO168	7781.5	357
453	SO169	7764.5	77
454	SO170	7747.5	217
455	SO171	7730.5	357
456	SO172	7713.5	77
457	SO173	7696.5	217
458	SO174	7679.5	357
459	SO175	7662.5	77
460	SO176	7645.5	217
461	SO177	7628.5	357
462	SO178	7611.5	77
463	SO179	7594.5	217
464	SO180	7577.5	357
465	SO181	7560.5	77
466	SO182	7543.5	217
467	SO183	7526.5	357
468	SO184	7509.5	77
469	SO185	7492.5	217
470	SO186	7475.5	357
471	SO187	7458.5	77
472	SO188	7441.5	217
473	SO189	7424.5	357
474	SO190	7407.5	77
475	SO191	7390.5	217
476	SO192	7373.5	357
477	SO193	7356.5	77
478	SO194	7339.5	217
479	SO195	7322.5	357
480	SO196	7305.5	77
481	SO197	7288.5	217
482	SO198	7271.5	357
483	SO199	7254.5	77
484	SO200	7237.5	217
485	SO201	7220.5	357
486	SO202	7203.5	77
487	SO203	7186.5	217
488	SO204	7169.5	357
489	SO205	7152.5	77
490	SO206	7135.5	217
491	SO207	7118.5	357
492	SO208	7101.5	77
493	SO209	7084.5	217
494	SO210	7067.5	357
495	SO211	7050.5	77
496	SO212	7033.5	217
497	SO213	7016.5	357
498	SO214	6999.5	77
499	SO215	6982.5	217
500	SO216	6965.5	357

No.	Name	X	Y
501	SO217	6948.5	77
502	SO218	6931.5	217
503	SO219	6914.5	357
504	SO220	6897.5	77
505	SO221	6880.5	217
506	SO222	6863.5	357
507	SO223	6846.5	77
508	SO224	6829.5	217
509	SO225	6812.5	357
510	SO226	6795.5	77
511	SO227	6778.5	217
512	SO228	6761.5	357
513	SO229	6744.5	77
514	SO230	6727.5	217
515	SO231	6710.5	357
516	SO232	6693.5	77
517	SO233	6676.5	217
518	SO234	6659.5	357
519	SO235	6642.5	77
520	SO236	6625.5	217
521	SO237	6608.5	357
522	SO238	6591.5	77
523	SO239	6574.5	217
524	SO240	6557.5	357
525	SO241	6540.5	77
526	SO242	6523.5	217
527	SO243	6506.5	357
528	SO244	6489.5	77
529	SO245	6472.5	217
530	SO246	6455.5	357
531	SO247	6438.5	77
532	SO248	6421.5	217
533	SO249	6404.5	357
534	SO250	6387.5	77
535	SO251	6370.5	217
536	SO252	6353.5	357
537	SO253	6336.5	77
538	SO254	6319.5	217
539	SO255	6302.5	357
540	SO256	6285.5	77
541	SO257	6268.5	217
542	SO258	6251.5	357
543	SO259	6234.5	77
544	SO260	6217.5	217
545	SO261	6200.5	357
546	SO262	6183.5	77
547	SO263	6166.5	217
548	SO264	6149.5	357
549	SO265	6132.5	77
550	SO266	6115.5	217

No.	Name	X	Y
551	SO267	6098.5	357
552	SO268	6081.5	77
553	SO269	6064.5	217
554	SO270	6047.5	357
555	SO271	6030.5	77
556	SO272	6013.5	217
557	SO273	5996.5	357
558	SO274	5979.5	77
559	SO275	5962.5	217
560	SO276	5945.5	357
561	SO277	5928.5	77
562	SO278	5911.5	217
563	SO279	5894.5	357
564	SO280	5877.5	77
565	SO281	5860.5	217
566	SO282	5843.5	357
567	SO283	5826.5	77
568	SO284	5809.5	217
569	SO285	5792.5	357
570	SO286	5775.5	77
571	SO287	5758.5	217
572	SO288	5741.5	357
573	SO289	5724.5	77
574	SO290	5707.5	217
575	SO291	5690.5	357
576	SO292	5673.5	77
577	SO293	5656.5	217
578	SO294	5639.5	357
579	SO295	5622.5	77
580	SO296	5605.5	217
581	SO297	5588.5	357
582	SO298	5571.5	77
583	SO299	5554.5	217
584	SO300	5537.5	357
585	SO301	5520.5	77
586	SO302	5503.5	217
587	SO303	5486.5	357
588	SO304	5469.5	77
589	SO305	5452.5	217
590	SO306	5435.5	357
591	SO307	5418.5	77
592	SO308	5401.5	217
593	SO309	5384.5	357
594	SO310	5367.5	77
595	SO311	5350.5	217
596	SO312	5333.5	357
597	SO313	5316.5	77
598	SO314	5299.5	217
599	SO315	5282.5	357
600	SO316	5265.5	77

No.	Name	X	Y
601	SO317	5248.5	217
602	SO318	5231.5	357
603	SO319	5214.5	77
604	SO320	5197.5	217
605	SO321	5180.5	357
606	SO322	5163.5	77
607	SO323	5146.5	217
608	SO324	5129.5	357
609	SO325	5112.5	77
610	SO326	5095.5	217
611	SO327	5078.5	357
612	SO328	5061.5	77
613	SO329	5044.5	217
614	SO330	5027.5	357
615	SO331	5010.5	77
616	SO332	4993.5	217
617	SO333	4976.5	357
618	SO334	4959.5	77
619	SO335	4942.5	217
620	SO336	4925.5	357
621	SO337	4908.5	77
622	SO338	4891.5	217
623	SO339	4874.5	357
624	SO340	4857.5	77
625	SO341	4840.5	217
626	SO342	4823.5	357
627	SO343	4806.5	77
628	SO344	4789.5	217
629	SO345	4772.5	357
630	SO346	4755.5	77
631	SO347	4738.5	217
632	SO348	4721.5	357
633	SO349	4704.5	77
634	SO350	4687.5	217
635	SO351	4670.5	357
636	SO352	4653.5	77
637	SO353	4636.5	217
638	SO354	4619.5	357
639	SO355	4602.5	77
640	SO356	4585.5	217
641	SO357	4568.5	357
642	SO358	4551.5	77
643	SO359	4534.5	217
644	SO360	4517.5	357
645	SO361	4500.5	77
646	SO362	4483.5	217
647	SO363	4466.5	357
648	SO364	4449.5	77
649	SO365	4432.5	217
650	SO366	4415.5	357

No.	Name	X	Y
651	SO367	4398.5	77
652	SO368	4381.5	217
653	SO369	4364.5	357
654	SO370	4347.5	77
655	SO371	4330.5	217
656	SO372	4313.5	357
657	SO373	4296.5	77
658	SO374	4279.5	217
659	SO375	4262.5	357
660	SO376	4245.5	77
661	SO377	4228.5	217
662	SO378	4211.5	357
663	SO379	4194.5	77
664	SO380	4177.5	217
665	SO381	4160.5	357
666	SO382	4143.5	77
667	SO383	4126.5	217
668	SO384	4109.5	357
669	SO385	4092.5	77
670	SO386	4075.5	217
671	SO387	4058.5	357
672	SO388	4041.5	77
673	SO389	4024.5	217
674	SO390	4007.5	357
675	SO391	3990.5	77
676	SO392	3973.5	217
677	SO393	3956.5	357
678	SO394	3939.5	77
679	SO395	3922.5	217
680	SO396	3905.5	357
681	SO397	3888.5	77
682	SO398	3871.5	217
683	SO399	3854.5	357
684	SO400	3837.5	77
685	SO401	3820.5	217
686	SO402	3803.5	357
687	SO403	3786.5	77
688	SO404	3769.5	217
689	SO405	3752.5	357
690	SO406	3735.5	77
691	SO407	3718.5	217
692	SO408	3701.5	357
693	SO409	3684.5	77
694	SO410	3667.5	217
695	SO411	3650.5	357
696	SO412	3633.5	77
697	SO413	3616.5	217
698	SO414	3599.5	357
699	SO415	3582.5	77
700	SO416	3565.5	217

No.	Name	X	Y
701	SO417	3548.5	357
702	SO418	3531.5	77
703	SO419	3514.5	217
704	SO420	3497.5	357
705	SO421	3480.5	77
706	SO422	3463.5	217
707	SO423	3446.5	357
708	SO424	3429.5	77
709	SO425	3412.5	217
710	SO426	3395.5	357
711	SO427	3378.5	77
712	SO428	3361.5	217
713	SO429	3344.5	357
714	SO430	3327.5	77
715	SO431	3310.5	217
716	SO432	3293.5	357
717	SO433	3276.5	77
718	SO434	3259.5	217
719	SO435	3242.5	357
720	SO436	3225.5	77
721	SO437	3208.5	217
722	SO438	3191.5	357
723	SO439	3174.5	77
724	SO440	3157.5	217
725	SO441	3140.5	357
726	SO442	3123.5	77
727	SO443	3106.5	217
728	SO444	3089.5	357
729	SO445	3072.5	77
730	SO446	3055.5	217
731	SO447	3038.5	357
732	SO448	3021.5	77
733	SO449	3004.5	217
734	SO450	2987.5	357
735	SO451	2970.5	77
736	SO452	2953.5	217
737	SO453	2936.5	357
738	SO454	2919.5	77
739	SO455	2902.5	217
740	SO456	2885.5	357
741	SO457	2868.5	77
742	SO458	2851.5	217
743	SO459	2834.5	357
744	SO460	2817.5	77
745	SO461	2800.5	217
746	SO462	2783.5	357
747	SO463	2766.5	77
748	SO464	2749.5	217
749	SO465	2732.5	357
750	SO466	2715.5	77

No.	Name	X	Y
751	SO467	2698.5	217
752	SO468	2681.5	357
753	SO469	2664.5	77
754	SO470	2647.5	217
755	SO471	2630.5	357
756	SO472	2613.5	77
757	SO473	2596.5	217
758	SO474	2579.5	357
759	SO475	2562.5	77
760	SO476	2545.5	217
761	SO477	2528.5	357
762	SO478	2511.5	77
763	SO479	2494.5	217
764	SO480	2477.5	357
765	SO481	2460.5	77
766	SO482	2443.5	217
767	SO483	2426.5	357
768	SO484	2409.5	77
769	SO485	2392.5	217
770	SO486	2375.5	357
771	SO487	2358.5	77
772	SO488	2341.5	217
773	SO489	2324.5	357
774	SO490	2307.5	77
775	SO491	2290.5	217
776	SO492	2273.5	357
777	SO493	2256.5	77
778	SO494	2239.5	217
779	SO495	2222.5	357
780	SO496	2205.5	77
781	SO497	2188.5	217
782	SO498	2171.5	357
783	SO499	2154.5	77
784	SO500	2137.5	217
785	SO501	2120.5	357
786	SO502	2103.5	77
787	SO503	2086.5	217
788	SO504	2069.5	357
789	SO505	2052.5	77
790	SO506	2035.5	217
791	SO507	2018.5	357
792	SO508	2001.5	77
793	SO509	1984.5	217
794	SO510	1967.5	357
795	SO511	1950.5	77
796	SO512	1933.5	217
797	SO513	1916.5	357
798	SO514	1899.5	77
799	SO515	1882.5	217
800	SO516	1865.5	357

No.	Name	X	Y
801	SO517	1848.5	77
802	SO518	1831.5	217
803	SO519	1814.5	357
804	SO520	1797.5	77
805	SO521	1780.5	217
806	SO522	1763.5	357
807	SO523	1746.5	77
808	SO524	1729.5	217
809	SO525	1712.5	357
810	SO526	1695.5	77
811	SO527	1678.5	217
812	SO528	1661.5	357
813	SO529	1644.5	77
814	SO530	1627.5	217
815	SO531	1610.5	357
816	SO532	1593.5	77
817	SO533	1576.5	217
818	SO534	1559.5	357
819	SO535	1542.5	77
820	SO536	1525.5	217
821	SO537	1508.5	357
822	SO538	1491.5	77
823	SO539	1474.5	217
824	SO540	1457.5	357
825	SO541	1440.5	77
826	SO542	1423.5	217
827	SO543	1406.5	357
828	SO544	1389.5	77
829	SO545	1372.5	217
830	SO546	1355.5	357
831	SO547	1338.5	77
832	SO548	1321.5	217
833	SO549	1304.5	357
834	SO550	1287.5	77
835	SO551	1270.5	217
836	SO552	1253.5	357
837	SO553	1236.5	77
838	SO554	1219.5	217
839	SO555	1202.5	357
840	SO556	1185.5	77
841	SO557	1168.5	217
842	SO558	1151.5	357
843	SO559	1134.5	77
844	SO560	1117.5	217
845	SO561	1100.5	357
846	SO562	1083.5	77
847	SO563	1066.5	217
848	SO564	1049.5	357
849	SO565	1032.5	77
850	SO566	1015.5	217

No.	Name	X	Y
851	SO567	998.5	357
852	SO568	981.5	77
853	SO569	964.5	217
854	SO570	947.5	357
855	SO571	930.5	77
856	SO572	913.5	217
857	SO573	896.5	357
858	SO574	879.5	77
859	SO575	862.5	217
860	SO576	845.5	357
861	SO577	828.5	77
862	SO578	811.5	217
863	SO579	794.5	357
864	SO580	777.5	77
865	SO581	760.5	217
866	SO582	743.5	357
867	SO583	726.5	77
868	SO584	709.5	217
869	SO585	692.5	357
870	SO586	675.5	77
871	SO587	658.5	217
872	SO588	641.5	357
873	SO589	624.5	77
874	SO590	607.5	217
875	SO591	590.5	357
876	SO592	573.5	77
877	SO593	556.5	217
878	SO594	539.5	357
879	SO595	522.5	77
880	SO596	505.5	217
881	SO597	488.5	357
882	SO598	471.5	77
883	SO599	454.5	217
884	SO600	437.5	357
885	SHIELDING	403.5	357
886	SHIELDING	369.5	357
887	SHIELDING	335.5	357
888	SHIELDING	301.5	357
889	SHIELDING	267.5	357
890	SHIELDING	233.5	357
891	SHIELDING	-233.5	357
892	SHIELDING	-267.5	357
893	SHIELDING	-301.5	357
894	SHIELDING	-335.5	357
895	SHIELDING	-369.5	357
896	SHIELDING	-403.5	357
897	SO601	-437.5	357
898	SO602	-454.5	217
899	SO603	-471.5	77
900	SO604	-488.5	357

No.	Name	X	Y
901	SO605	-505.5	217
902	SO606	-522.5	77
903	SO607	-539.5	357
904	SO608	-556.5	217
905	SO609	-573.5	77
906	SO610	-590.5	357
907	SO611	-607.5	217
908	SO612	-624.5	77
909	SO613	-641.5	357
910	SO614	-658.5	217
911	SO615	-675.5	77
912	SO616	-692.5	357
913	SO617	-709.5	217
914	SO618	-726.5	77
915	SO619	-743.5	357
916	SO620	-760.5	217
917	SO621	-777.5	77
918	SO622	-794.5	357
919	SO623	-811.5	217
920	SO624	-828.5	77
921	SO625	-845.5	357
922	SO626	-862.5	217
923	SO627	-879.5	77
924	SO628	-896.5	357
925	SO629	-913.5	217
926	SO630	-930.5	77
927	SO631	-947.5	357
928	SO632	-964.5	217
929	SO633	-981.5	77
930	SO634	-998.5	357
931	SO635	-1015.5	217
932	SO636	-1032.5	77
933	SO637	-1049.5	357
934	SO638	-1066.5	217
935	SO639	-1083.5	77
936	SO640	-1100.5	357
937	SO641	-1117.5	217
938	SO642	-1134.5	77
939	SO643	-1151.5	357
940	SO644	-1168.5	217
941	SO645	-1185.5	77
942	SO646	-1202.5	357
943	SO647	-1219.5	217
944	SO648	-1236.5	77
945	SO649	-1253.5	357
946	SO650	-1270.5	217
947	SO651	-1287.5	77
948	SO652	-1304.5	357
949	SO653	-1321.5	217
950	SO654	-1338.5	77

No.	Name	X	Y
951	SO655	-1355.5	357
952	SO656	-1372.5	217
953	SO657	-1389.5	77
954	SO658	-1406.5	357
955	SO659	-1423.5	217
956	SO660	-1440.5	77
957	SO661	-1457.5	357
958	SO662	-1474.5	217
959	SO663	-1491.5	77
960	SO664	-1508.5	357
961	SO665	-1525.5	217
962	SO666	-1542.5	77
963	SO667	-1559.5	357
964	SO668	-1576.5	217
965	SO669	-1593.5	77
966	SO670	-1610.5	357
967	SO671	-1627.5	217
968	SO672	-1644.5	77
969	SO673	-1661.5	357
970	SO674	-1678.5	217
971	SO675	-1695.5	77
972	SO676	-1712.5	357
973	SO677	-1729.5	217
974	SO678	-1746.5	77
975	SO679	-1763.5	357
976	SO680	-1780.5	217
977	SO681	-1797.5	77
978	SO682	-1814.5	357
979	SO683	-1831.5	217
980	SO684	-1848.5	77
981	SO685	-1865.5	357
982	SO686	-1882.5	217
983	SO687	-1899.5	77
984	SO688	-1916.5	357
985	SO689	-1933.5	217
986	SO690	-1950.5	77
987	SO691	-1967.5	357
988	SO692	-1984.5	217
989	SO693	-2001.5	77
990	SO694	-2018.5	357
991	SO695	-2035.5	217
992	SO696	-2052.5	77
993	SO697	-2069.5	357
994	SO698	-2086.5	217
995	SO699	-2103.5	77
996	SO700	-2120.5	357
997	SO701	-2137.5	217
998	SO702	-2154.5	77
999	SO703	-2171.5	357
1000	SO704	-2188.5	217

No.	Name	X	Y
1001	SO705	-2205.5	77
1002	SO706	-2222.5	357
1003	SO707	-2239.5	217
1004	SO708	-2256.5	77
1005	SO709	-2273.5	357
1006	SO710	-2290.5	217
1007	SO711	-2307.5	77
1008	SO712	-2324.5	357
1009	SO713	-2341.5	217
1010	SO714	-2358.5	77
1011	SO715	-2375.5	357
1012	SO716	-2392.5	217
1013	SO717	-2409.5	77
1014	SO718	-2426.5	357
1015	SO719	-2443.5	217
1016	SO720	-2460.5	77
1017	SO721	-2477.5	357
1018	SO722	-2494.5	217
1019	SO723	-2511.5	77
1020	SO724	-2528.5	357
1021	SO725	-2545.5	217
1022	SO726	-2562.5	77
1023	SO727	-2579.5	357
1024	SO728	-2596.5	217
1025	SO729	-2613.5	77
1026	SO730	-2630.5	357
1027	SO731	-2647.5	217
1028	SO732	-2664.5	77
1029	SO733	-2681.5	357
1030	SO734	-2698.5	217
1031	SO735	-2715.5	77
1032	SO736	-2732.5	357
1033	SO737	-2749.5	217
1034	SO738	-2766.5	77
1035	SO739	-2783.5	357
1036	SO740	-2800.5	217
1037	SO741	-2817.5	77
1038	SO742	-2834.5	357
1039	SO743	-2851.5	217
1040	SO744	-2868.5	77
1041	SO745	-2885.5	357
1042	SO746	-2902.5	217
1043	SO747	-2919.5	77
1044	SO748	-2936.5	357
1045	SO749	-2953.5	217
1046	SO750	-2970.5	77
1047	SO751	-2987.5	357
1048	SO752	-3004.5	217
1049	SO753	-3021.5	77
1050	SO754	-3038.5	357

No.	Name	X	Y
1051	SO755	-3055.5	217
1052	SO756	-3072.5	77
1053	SO757	-3089.5	357
1054	SO758	-3106.5	217
1055	SO759	-3123.5	77
1056	SO760	-3140.5	357
1057	SO761	-3157.5	217
1058	SO762	-3174.5	77
1059	SO763	-3191.5	357
1060	SO764	-3208.5	217
1061	SO765	-3225.5	77
1062	SO766	-3242.5	357
1063	SO767	-3259.5	217
1064	SO768	-3276.5	77
1065	SO769	-3293.5	357
1066	SO770	-3310.5	217
1067	SO771	-3327.5	77
1068	SO772	-3344.5	357
1069	SO773	-3361.5	217
1070	SO774	-3378.5	77
1071	SO775	-3395.5	357
1072	SO776	-3412.5	217
1073	SO777	-3429.5	77
1074	SO778	-3446.5	357
1075	SO779	-3463.5	217
1076	SO780	-3480.5	77
1077	SO781	-3497.5	357
1078	SO782	-3514.5	217
1079	SO783	-3531.5	77
1080	SO784	-3548.5	357
1081	SO785	-3565.5	217
1082	SO786	-3582.5	77
1083	SO787	-3599.5	357
1084	SO788	-3616.5	217
1085	SO789	-3633.5	77
1086	SO790	-3650.5	357
1087	SO791	-3667.5	217
1088	SO792	-3684.5	77
1089	SO793	-3701.5	357
1090	SO794	-3718.5	217
1091	SO795	-3735.5	77
1092	SO796	-3752.5	357
1093	SO797	-3769.5	217
1094	SO798	-3786.5	77
1095	SO799	-3803.5	357
1096	SO800	-3820.5	217
1097	SO801	-3837.5	77
1098	SO802	-3854.5	357
1099	SO803	-3871.5	217
1100	SO804	-3888.5	77

No.	Name	X	Y
1101	SO805	-3905.5	357
1102	SO806	-3922.5	217
1103	SO807	-3939.5	77
1104	SO808	-3956.5	357
1105	SO809	-3973.5	217
1106	SO810	-3990.5	77
1107	SO811	-4007.5	357
1108	SO812	-4024.5	217
1109	SO813	-4041.5	77
1110	SO814	-4058.5	357
1111	SO815	-4075.5	217
1112	SO816	-4092.5	77
1113	SO817	-4109.5	357
1114	SO818	-4126.5	217
1115	SO819	-4143.5	77
1116	SO820	-4160.5	357
1117	SO821	-4177.5	217
1118	SO822	-4194.5	77
1119	SO823	-4211.5	357
1120	SO824	-4228.5	217
1121	SO825	-4245.5	77
1122	SO826	-4262.5	357
1123	SO827	-4279.5	217
1124	SO828	-4296.5	77
1125	SO829	-4313.5	357
1126	SO830	-4330.5	217
1127	SO831	-4347.5	77
1128	SO832	-4364.5	357
1129	SO833	-4381.5	217
1130	SO834	-4398.5	77
1131	SO835	-4415.5	357
1132	SO836	-4432.5	217
1133	SO837	-4449.5	77
1134	SO838	-4466.5	357
1135	SO839	-4483.5	217
1136	SO840	-4500.5	77
1137	SO841	-4517.5	357
1138	SO842	-4534.5	217
1139	SO843	-4551.5	77
1140	SO844	-4568.5	357
1141	SO845	-4585.5	217
1142	SO846	-4602.5	77
1143	SO847	-4619.5	357
1144	SO848	-4636.5	217
1145	SO849	-4653.5	77
1146	SO850	-4670.5	357
1147	SO851	-4687.5	217
1148	SO852	-4704.5	77
1149	SO853	-4721.5	357
1150	SO854	-4738.5	217

No.	Name	X	Y
1151	SO855	-4755.5	77
1152	SO856	-4772.5	357
1153	SO857	-4789.5	217
1154	SO858	-4806.5	77
1155	SO859	-4823.5	357
1156	SO860	-4840.5	217
1157	SO861	-4857.5	77
1158	SO862	-4874.5	357
1159	SO863	-4891.5	217
1160	SO864	-4908.5	77
1161	SO865	-4925.5	357
1162	SO866	-4942.5	217
1163	SO867	-4959.5	77
1164	SO868	-4976.5	357
1165	SO869	-4993.5	217
1166	SO870	-5010.5	77
1167	SO871	-5027.5	357
1168	SO872	-5044.5	217
1169	SO873	-5061.5	77
1170	SO874	-5078.5	357
1171	SO875	-5095.5	217
1172	SO876	-5112.5	77
1173	SO877	-5129.5	357
1174	SO878	-5146.5	217
1175	SO879	-5163.5	77
1176	SO880	-5180.5	357
1177	SO881	-5197.5	217
1178	SO882	-5214.5	77
1179	SO883	-5231.5	357
1180	SO884	-5248.5	217
1181	SO885	-5265.5	77
1182	SO886	-5282.5	357
1183	SO887	-5299.5	217
1184	SO888	-5316.5	77
1185	SO889	-5333.5	357
1186	SO890	-5350.5	217
1187	SO891	-5367.5	77
1188	SO892	-5384.5	357
1189	SO893	-5401.5	217
1190	SO894	-5418.5	77
1191	SO895	-5435.5	357
1192	SO896	-5452.5	217
1193	SO897	-5469.5	77
1194	SO898	-5486.5	357
1195	SO899	-5503.5	217
1196	SO900	-5520.5	77
1197	SO901	-5537.5	357
1198	SO902	-5554.5	217
1199	SO903	-5571.5	77
1200	SO904	-5588.5	357

No.	Name	X	Y
1201	SO905	-5605.5	217
1202	SO906	-5622.5	77
1203	SO907	-5639.5	357
1204	SO908	-5656.5	217
1205	SO909	-5673.5	77
1206	SO910	-5690.5	357
1207	SO911	-5707.5	217
1208	SO912	-5724.5	77
1209	SO913	-5741.5	357
1210	SO914	-5758.5	217
1211	SO915	-5775.5	77
1212	SO916	-5792.5	357
1213	SO917	-5809.5	217
1214	SO918	-5826.5	77
1215	SO919	-5843.5	357
1216	SO920	-5860.5	217
1217	SO921	-5877.5	77
1218	SO922	-5894.5	357
1219	SO923	-5911.5	217
1220	SO924	-5928.5	77
1221	SO925	-5945.5	357
1222	SO926	-5962.5	217
1223	SO927	-5979.5	77
1224	SO928	-5996.5	357
1225	SO929	-6013.5	217
1226	SO930	-6030.5	77
1227	SO931	-6047.5	357
1228	SO932	-6064.5	217
1229	SO933	-6081.5	77
1230	SO934	-6098.5	357
1231	SO935	-6115.5	217
1232	SO936	-6132.5	77
1233	SO937	-6149.5	357
1234	SO938	-6166.5	217
1235	SO939	-6183.5	77
1236	SO940	-6200.5	357
1237	SO941	-6217.5	217
1238	SO942	-6234.5	77
1239	SO943	-6251.5	357
1240	SO944	-6268.5	217
1241	SO945	-6285.5	77
1242	SO946	-6302.5	357
1243	SO947	-6319.5	217
1244	SO948	-6336.5	77
1245	SO949	-6353.5	357
1246	SO950	-6370.5	217
1247	SO951	-6387.5	77
1248	SO952	-6404.5	357
1249	SO953	-6421.5	217
1250	SO954	-6438.5	77

No.	Name	X	Y
1251	SO955	-6455.5	357
1252	SO956	-6472.5	217
1253	SO957	-6489.5	77
1254	SO958	-6506.5	357
1255	SO959	-6523.5	217
1256	SO960	-6540.5	77
1257	SO961	-6557.5	357
1258	SO962	-6574.5	217
1259	SO963	-6591.5	77
1260	SO964	-6608.5	357
1261	SO965	-6625.5	217
1262	SO966	-6642.5	77
1263	SO967	-6659.5	357
1264	SO968	-6676.5	217
1265	SO969	-6693.5	77
1266	SO970	-6710.5	357
1267	SO971	-6727.5	217
1268	SO972	-6744.5	77
1269	SO973	-6761.5	357
1270	SO974	-6778.5	217
1271	SO975	-6795.5	77
1272	SO976	-6812.5	357
1273	SO977	-6829.5	217
1274	SO978	-6846.5	77
1275	SO979	-6863.5	357
1276	SO980	-6880.5	217
1277	SO981	-6897.5	77
1278	SO982	-6914.5	357
1279	SO983	-6931.5	217
1280	SO984	-6948.5	77
1281	SO985	-6965.5	357
1282	SO986	-6982.5	217
1283	SO987	-6999.5	77
1284	SO988	-7016.5	357
1285	SO989	-7033.5	217
1286	SO990	-7050.5	77
1287	SO991	-7067.5	357
1288	SO992	-7084.5	217
1289	SO993	-7101.5	77
1290	SO994	-7118.5	357
1291	SO995	-7135.5	217
1292	SO996	-7152.5	77
1293	SO997	-7169.5	357
1294	SO998	-7186.5	217
1295	SO999	-7203.5	77
1296	SO1000	-7220.5	357
1297	SO1001	-7237.5	217
1298	SO1002	-7254.5	77
1299	SO1003	-7271.5	357
1300	SO1004	-7288.5	217

No.	Name	X	Y
1301	SO1005	-7305.5	77
1302	SO1006	-7322.5	357
1303	SO1007	-7339.5	217
1304	SO1008	-7356.5	77
1305	SO1009	-7373.5	357
1306	SO1010	-7390.5	217
1307	SO1011	-7407.5	77
1308	SO1012	-7424.5	357
1309	SO1013	-7441.5	217
1310	SO1014	-7458.5	77
1311	SO1015	-7475.5	357
1312	SO1016	-7492.5	217
1313	SO1017	-7509.5	77
1314	SO1018	-7526.5	357
1315	SO1019	-7543.5	217
1316	SO1020	-7560.5	77
1317	SO1021	-7577.5	357
1318	SO1022	-7594.5	217
1319	SO1023	-7611.5	77
1320	SO1024	-7628.5	357
1321	SO1025	-7645.5	217
1322	SO1026	-7662.5	77
1323	SO1027	-7679.5	357
1324	SO1028	-7696.5	217
1325	SO1029	-7713.5	77
1326	SO1030	-7730.5	357
1327	SO1031	-7747.5	217
1328	SO1032	-7764.5	77
1329	SO1033	-7781.5	357
1330	SO1034	-7798.5	217
1331	SO1035	-7815.5	77
1332	SO1036	-7832.5	357
1333	SO1037	-7849.5	217
1334	SO1038	-7866.5	77
1335	SO1039	-7883.5	357
1336	SO1040	-7900.5	217
1337	SO1041	-7917.5	77
1338	SO1042	-7934.5	357
1339	SO1043	-7951.5	217
1340	SO1044	-7968.5	77
1341	SO1045	-7985.5	357
1342	SO1046	-8002.5	217
1343	SO1047	-8019.5	77
1344	SO1048	-8036.5	357
1345	SO1049	-8053.5	217
1346	SO1050	-8070.5	77
1347	SO1051	-8087.5	357
1348	SO1052	-8104.5	217
1349	SO1053	-8121.5	77
1350	SO1054	-8138.5	357

No.	Name	X	Y
1351	SO1055	-8155.5	217
1352	SO1056	-8172.5	77
1353	SO1057	-8189.5	357
1354	SO1058	-8206.5	217
1355	SO1059	-8223.5	77
1356	SO1060	-8240.5	357
1357	SO1061	-8257.5	217
1358	SO1062	-8274.5	77
1359	SO1063	-8291.5	357
1360	SO1064	-8308.5	217
1361	SO1065	-8325.5	77
1362	SO1066	-8342.5	357
1363	SO1067	-8359.5	217
1364	SO1068	-8376.5	77
1365	SO1069	-8393.5	357
1366	SO1070	-8410.5	217
1367	SO1071	-8427.5	77
1368	SO1072	-8444.5	357
1369	SO1073	-8461.5	217
1370	SO1074	-8478.5	77
1371	SO1075	-8495.5	357
1372	SO1076	-8512.5	217
1373	SO1077	-8529.5	77
1374	SO1078	-8546.5	357
1375	SO1079	-8563.5	217
1376	SO1080	-8580.5	77
1377	SO1081	-8597.5	357
1378	SO1082	-8614.5	217
1379	SO1083	-8631.5	77
1380	SO1084	-8648.5	357
1381	SO1085	-8665.5	217
1382	SO1086	-8682.5	77
1383	SO1087	-8699.5	357
1384	SO1088	-8716.5	217
1385	SO1089	-8733.5	77
1386	SO1090	-8750.5	357
1387	SO1091	-8767.5	217
1388	SO1092	-8784.5	77
1389	SO1093	-8801.5	357
1390	SO1094	-8818.5	217
1391	SO1095	-8835.5	77
1392	SO1096	-8852.5	357
1393	SO1097	-8869.5	217
1394	SO1098	-8886.5	77
1395	SO1099	-8903.5	357
1396	SO1100	-8920.5	217
1397	SO1101	-8937.5	77
1398	SO1102	-8954.5	357
1399	SO1103	-8971.5	217
1400	SO1104	-8988.5	77

No.	Name	X	Y
1401	SO1105	-9005.5	357
1402	SO1106	-9022.5	217
1403	SO1107	-9039.5	77
1404	SO1108	-9056.5	357
1405	SO1109	-9073.5	217
1406	SO1110	-9090.5	77
1407	SO1111	-9107.5	357
1408	SO1112	-9124.5	217
1409	SO1113	-9141.5	77
1410	SO1114	-9158.5	357
1411	SO1115	-9175.5	217
1412	SO1116	-9192.5	77
1413	SO1117	-9209.5	357
1414	SO1118	-9226.5	217
1415	SO1119	-9243.5	77
1416	SO1120	-9260.5	357
1417	SO1121	-9277.5	217
1418	SO1122	-9294.5	77
1419	SO1123	-9311.5	357
1420	SO1124	-9328.5	217
1421	SO1125	-9345.5	77
1422	SO1126	-9362.5	357
1423	SO1127	-9379.5	217
1424	SO1128	-9396.5	77
1425	SO1129	-9413.5	357
1426	SO1130	-9430.5	217
1427	SO1131	-9447.5	77
1428	SO1132	-9464.5	357
1429	SO1133	-9481.5	217
1430	SO1134	-9498.5	77
1431	SO1135	-9515.5	357
1432	SO1136	-9532.5	217
1433	SO1137	-9549.5	77
1434	SO1138	-9566.5	357
1435	SO1139	-9583.5	217
1436	SO1140	-9600.5	77
1437	SO1141	-9617.5	357
1438	SO1142	-9634.5	217
1439	SO1143	-9651.5	77
1440	SO1144	-9668.5	357
1441	SO1145	-9685.5	217
1442	SO1146	-9702.5	77
1443	SO1147	-9719.5	357
1444	SO1148	-9736.5	217
1445	SO1149	-9753.5	77
1446	SO1150	-9770.5	357
1447	SO1151	-9787.5	217
1448	SO1152	-9804.5	77
1449	SO1153	-9821.5	357
1450	SO1154	-9838.5	217

No.	Name	X	Y
1451	SO1155	-9855.5	77
1452	SO1156	-9872.5	357
1453	SO1157	-9889.5	217
1454	SO1158	-9906.5	77
1455	SO1159	-9923.5	357
1456	SO1160	-9940.5	217
1457	SO1161	-9957.5	77
1458	SO1162	-9974.5	357
1459	SO1163	-9991.5	217
1460	SO1164	-10008.5	77
1461	SO1165	-10025.5	357
1462	SO1166	-10042.5	217
1463	SO1167	-10059.5	77
1464	SO1168	-10076.5	357
1465	SO1169	-10093.5	217
1466	SO1170	-10110.5	77
1467	SO1171	-10127.5	357
1468	SO1172	-10144.5	217
1469	SO1173	-10161.5	77
1470	SO1174	-10178.5	357
1471	SO1175	-10195.5	217
1472	SO1176	-10212.5	77
1473	SO1177	-10229.5	357
1474	SO1178	-10246.5	217
1475	SO1179	-10263.5	77
1476	SO1180	-10280.5	357
1477	SO1181	-10297.5	217
1478	SO1182	-10314.5	77
1479	SO1183	-10331.5	357
1480	SO1184	-10348.5	217
1481	SO1185	-10365.5	77
1482	SO1186	-10382.5	357
1483	SO1187	-10399.5	217
1484	SO1188	-10416.5	77
1485	SO1189	-10433.5	357
1486	SO1190	-10450.5	217
1487	SO1191	-10467.5	77
1488	SO1192	-10484.5	357
1489	SO1193	-10501.5	217
1490	SO1194	-10518.5	77
1491	SO1195	-10535.5	357
1492	SO1196	-10552.5	217
1493	SO1197	-10569.5	77
1494	SO1198	-10586.5	357
1495	SO1199	-10603.5	217
1496	SO1200	-10620.5	77
1497	SHIELDING	-10664	377
1498	COM1_T	-10714	377
1499	COM1_T	-10764	377
1500	SYNCR	-10814	377

No.	Name	X	Y
1501	LDR	-10864	377
1502	POLR	-10914	377
1503	DATR0	-11179	397
1504	DATR1	-11049	357
1505	DATR2	-11179	317
1506	DATR3	-11049	277
1507	DATR4	-11179	237
1508	DATR5	-11049	197
1509	DATR6	-11179	157
1510	DATR7	-11049	117
1511	DATR8	-11179	77
1512	DATR9	-11049	37
1513	DATR10	-11179	-3
1514	DATR11	-11049	-43
1515	DATR12	-11179	-83
1516	DATR13	-11049	-123
1517	DATR14	-11179	-163
1518	DATR15	-11049	-203
1519	DATR16	-11179	-243
1520	DATR17	-11049	-283
1521	DIOR	-11179	-323
1522	DCLKR	-11049	-363

ALIGNMENT_MARK_R	10773	93
ALIGNMENT_MARK_L	-10773	93

Himax Confidential
Do Not Copy

15. Ordering Information

Part No.	Package Type
HX8264-D02000PDxxx	PD : mean COG xxx : mean chip thickness (µm) (default 400µm)

16. Revision History

Version	Date	Description of changes
01	2010/04/23	New setup

Himax Confidential
Do Not Copy

With collaboration of <https://www.displayfuture.com>