

# True Multi-Touch Capacitive Touch Panel Controller

## INTRODUCTION

The FT5x06 Series ICs are single-chip capacitive touch panel controller ICs with a built-in 8 bit Micro-controller unit (MCU). They adopt the mutual capacitance approach, which supports true multi-touch capability. In conjunction with a mutual capacitive touch panel, the FT5x06 have user-friendly input functions, which can be applied on many portable devices, such as cellular phones, MIDs, netbook and notebook personal computers.

The FT5x06 series ICs include FT5206/FT5306/FT5406, the difference of their specifications will be listed individually in this datasheet.

## FEATURES

- Mutual Capacitive Sensing Techniques
- True Multi-touch with up to 10 Points of Absolution X and Y Coordinates
- Immune to RF Interferences
- Auto-calibration: Insensitive to Capacitance and Environmental Variations
- Supports up to 28 Transmit Lines and 16 Receive Lines
- Supports up to 8.9" Touch Screen
- Full Programmable Scan Sequences with Individual Adjustable Receive Lines and Transmit Lines to Support Various Applications
- High Report Rate: More than 100Hz
- Touch Resolution of 100 Dots per Inch (dpi) or above -- depending on the Panel Size
- Optional Interfaces :I2C/SPI
- 2.8V to 3.6V Operating Voltage
- Supports 1.8V/AVDD IOVCC
- Capable of Driving Single Channel (transmit/receive) Resistance: Up to 15K  $\Omega$
- Capable of Supporting Single Channel (transmit/receive) Capacitance: 60 pF
- Optimal Sensing Mutual Capacitor: 1pF~4pF
- 12-Bit ADC Accuracy
- Built-in MCU with 28KB Program Memory, 6KB Data Memory and 256B Internal Data Space
- 11 Internal Interrupt Sources and 2 External Interrupt Sources
- 3 Operating Modes
  - Active
  - Monitor
  - Hibernate
- Operating Temperature Range: -40°C to +85°C



## TABLE OF CONTENTS

INTRODUCTION.....	I
FEATURES .....	I
<b>1 OVERVIEW .....</b>	<b>1</b>
<b>1.1 TYPICAL APPLICATIONS .....</b>	<b>1</b>
<b>2 FUNCTIONAL DESCRIPTION .....</b>	<b>1</b>
<b>2.1 ARCHITECTURAL OVERVIEW.....</b>	<b>1</b>
<b>2.2 MCU .....</b>	<b>2</b>
<b>2.3 OPERATION MODES .....</b>	<b>2</b>
<b>2.4 HOST INTERFACE.....</b>	<b>3</b>
<b>2.5 SERIAL INTERFACE .....</b>	<b>3</b>
2.5.1 I2C.....	3
2.5.2 SPI.....	4
<b>3 ELECTRICAL SPECIFICATIONS .....</b>	<b>8</b>
<b>3.1 ABSOLUTE MAXIMUM RATINGS .....</b>	<b>8</b>
<b>3.2 DC CHARACTERISTICS .....</b>	<b>9</b>
<b>3.3 AC CHARACTERISTICS .....</b>	<b>9</b>
<b>3.4 I/O PORTS CIRCUITS .....</b>	<b>10</b>
<b>3.5 POWER ON/RESET/WAKE SEQUENCE .....</b>	<b>11</b>
<b>4 PIN CONFIGURATIONS .....</b>	<b>12</b>
<b>5 PACKAGE INFORMATION.....</b>	<b>15</b>
<b>5.1 PACKAGE INFORMATION OF QFN-5x5-40L PACKAGE .....</b>	<b>15</b>
<b>5.2 PACKAGE INFORMATION OF QFN-6x6-48L PACKAGE .....</b>	<b>16</b>
<b>5.3 PACKAGE INFORMATION OF QFN-8x8-68L PACKAGE .....</b>	<b>17</b>
<b>5.4 ORDER INFORMATION .....</b>	<b>18</b>

## 1 OVERVIEW

### 1.1 Typical Applications

FT5x06 accommodate a wide range of applications with a set of buttons up to a 2D touch sensing device, their typical applications are listed below.

- Mobile phones, smart phones
- MIDs
- Netbook
- Navigation systems, GPS
- Game consoles
- Car applications
- POS (Point of Sales) devices
- Portable MP3 and MP4 media players
- Digital cameras

FT5x06 Series ICs support 2.8"~8.9" Touch Panel, users may find out their target IC from the specs. listed in the following table,

Model Name	Panel		Package			Touch Panel Size
	TX	RX	Type	Pin	Size	
FT5206GE1	15	10	QFN5*5	40	0.75-P0.4	2.8"~3.8"
FT5306DE4	20	12	QFN6*6	48	0.75-P0.4	4.3"~7"
FT5406EE8	28	16	QFN8*8	68	0.75-P0.4	7"~8.9"

## 2 FUNCTIONAL DESCRIPTION

### 2.1 Architectural Overview

Figure2-1 shows the overall architecture for the FT5x06.

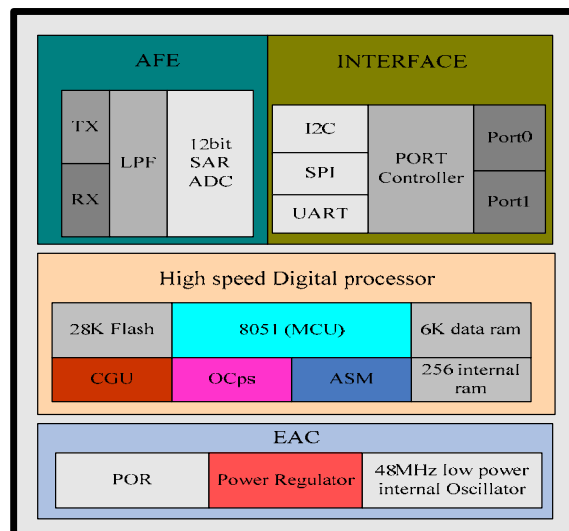

Figure 2-1 FT5x06 System Architecture Diagram

The FT5x06 is comprised of five main functional parts listed below,

- Touch Panel Interface Circuits

The main function for the AFE and AFE controller is to interface with the touch panel. It scans the panel by sending AC signals to the panel and processes the received signals from the panel. So, it supports both Transmit (TX) and Receive (RX) functions. Key parameters to configure this circuit can be sent via serial interfaces, which will be explained in detail in a later section.

- 8051-based MCU

This MCU is 8051 compatible with some enhancements. For instant, larger program and data memories are supported. In addition, a Multiplication-Division unit (MDU) is implemented to speed up the touch detection algorithms. Furthermore, a Flash ROM is implemented to store programs and some key parameters.

Complex signal processing algorithms are implemented with firmware running on this MCU to process further the received signals in order to detect the touches reliably. Communication protocol software is also implemented on this MCU to exchange data and control information with the host processor.

- External Interface

- I2C/SPI: an interface for data exchange with host
- INT: an interrupt signal to inform the host processor that touch data is ready for read
- WAKE: an interrupt signal for the host to change F5x06 from Hibernate to Active mode
- /RST: an external low signal reset the chip.

- A watch dog timer is implemented to ensure the robustness of the chip.

- A voltage regulator to generate 1.8V for digital circuits from the input VDD3 supply

## 2.2 MCU

This section describes some critical features and operations supported by the 8051 compatible MCU.

Figure 2-2 shows the overall structure of the MCU block. In addition to the 8051 compatible MCU core, we have added the following circuits,

- MDU: A 16x8 Multiplier and A 32/32 Divider
- Program Memory: 28KB Flash
- Data Memory: 6KB SRAM
- Real Time Clock (RTC): A 32KHz RC Oscillator
- Timer: A number of timers are available to generate different clocks
- Master Clock: 24/ 48MHz from a 48MHz RC Oscillator
- Clock Manager: To control various clocks under different operation conditions of the system

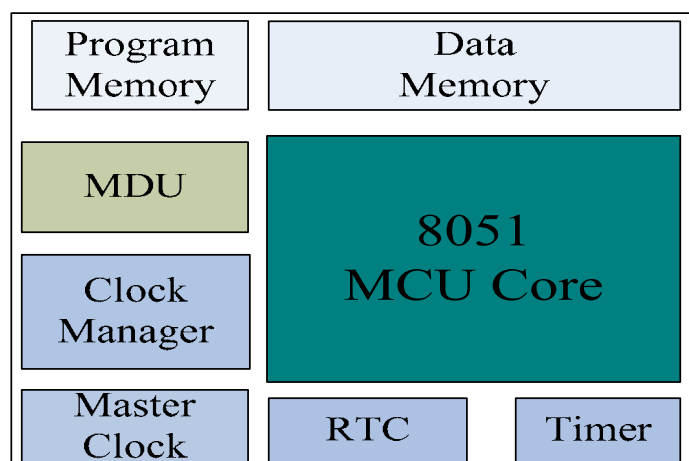

Figure 2-2 MCU Block Diagram

## 2.3 Operation Modes

FT5x06 operates in the following three modes:

- Active Mode

When in this mode, FT5x06 actively scans the panel. The default scan rate is 60 frames per second. The host processor can configure FT5x06 to speed up or to slow down.

● Monitor Mode

When in this mode, FT5x06 scans the panel at a reduced speed. The default scan rate is 25 frames per second and the host processor can increase or decrease this rate. When in this mode, most algorithms are stopped. A simpler algorithm is being executed to determine if there is a touch or not. When a touch is detected, FT5x06 shall enter the Active mode immediately to acquire the touch information quickly. During this mode, the serial port is closed and no data shall be transferred with the host processor.

● Hibernate Mode

In this mode, the chip is set in a power down mode. It shall only respond to the “WAKE” or “RESET” signal from the host processor. The chip therefore consumes very little current, which help prolong the standby time for the portable devices.

**2.4 Host Interface**

Figure 2-3 shows the interface between a host processor and FT5x06. This interface consists of the following three sets of signals:

- Serial Interface
- Interrupt from FT5x06 to the Host
- Wake-up Signal from the Host to FT5x06

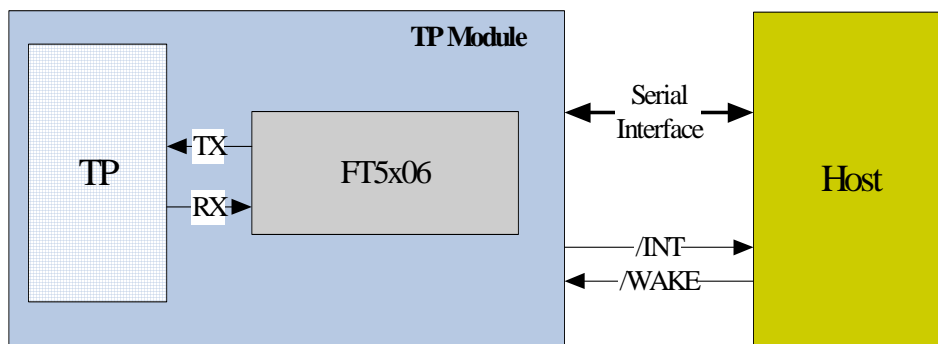

Figure 2-3 Host Interface Diagram

The serial interfaces of FT5x06 is I2C or SPI. The details of this interface are described in detail in Section 2.5. The interrupt signal (/INT) is used for FT5x06 to inform the host that data are ready for the host to receive. The /WAKE signal is used for the host to wake up FT5x06 from the Hibernate mode. After exiting the Hibernate mode, FT5x06 shall enter the Active mode.

**2.5 Serial Interface**

FT5x06 supports the I2C or SPI interfaces, which can be used by a host processor or other devices.

**2.5.1 I2C**

The I2C is always configured in the Slave mode. The data transfer format is shown in Figure 2-4.

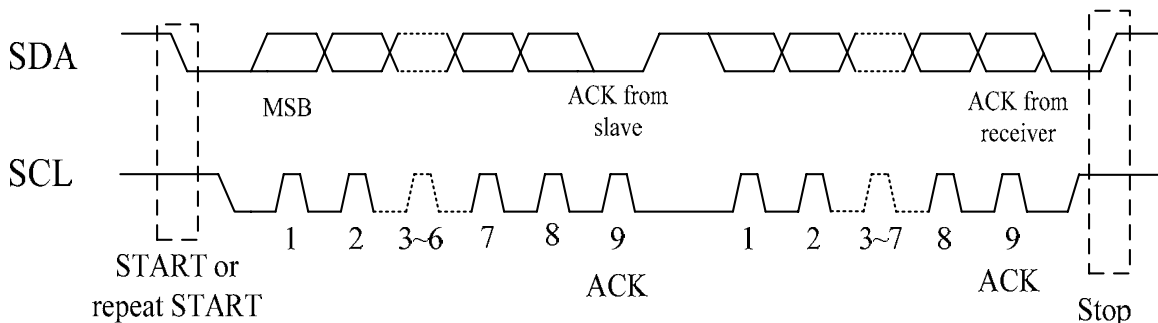

Figure 2-4 I2C Serial Data Transfer Format

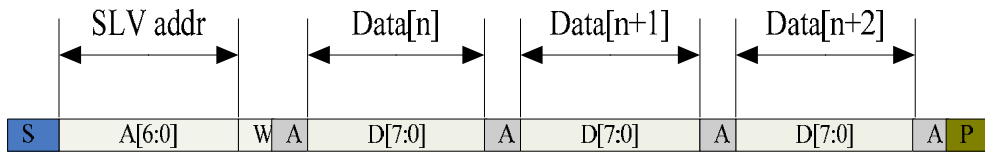

Figure 2-5 I2C master write, slave read

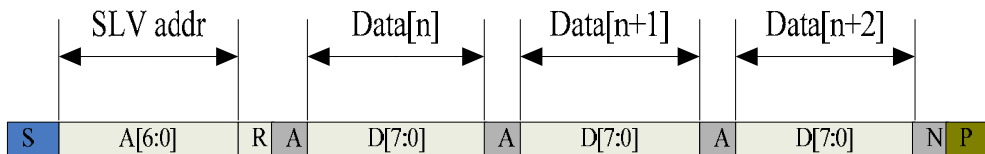

Figure 2-6 I2C master read, slave write

Table 2-1 lists the meanings of the mnemonics used in the above figures.

**Table 2-1 Mnemonics Description**

Mnemonics	Description
S	I2C Start or I2C Restart
A[6:0]	Slave address A[6:4]: 3'b011 A[3:0]: data bits are identical to those of I2CCON[7:4] register.
W	1'b0: Write
R	1'b1: Read
A(N)	ACK(NACK)
P	STOP: the indication of the end of a packet (if this bit is missing, S will indicate the end of the current packet and the beginning of the next packet)

I2C Interface Timing Characteristics is shown in Table 2-2.

**Table 2-2 I2C Timing Characteristics**

Parameter	Unit	Min	Max
SCL frequency	KHz	0	400
Bus free time between a STOP and START condition	us	4.7	\
Hold time (repeated) START condition	us	4.0	\
Data setup time	ns	250	\
Setup time for a repeated START condition	us	4.7	\
Setup Time for STOP condition	us	4.0	\

### 2.5.2 SPI

SPI is a 4 wire serial interface. The following is a list of the 4 wires:

- SCK: serial data clock
- MOSI: data line from master to slave
- MISO: data line from slave to master
- SLVESEL: active low select signal

SPI transfers data at 8bit packets. The phase relationship between the data and the clock can be defined by the two registers: phase and polck. Some data transfer examples can be found in Figure 2-7 to Figure 2-10.

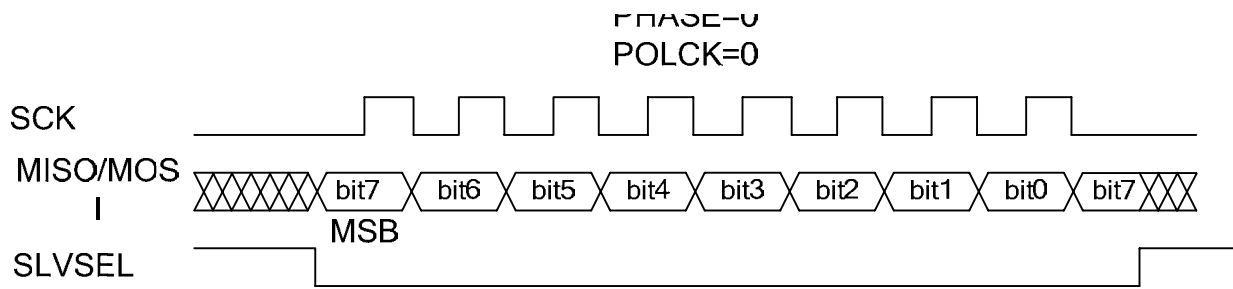

Figure 2-7 SPI Data Transfer Format (Phase=0, POLCK=0)

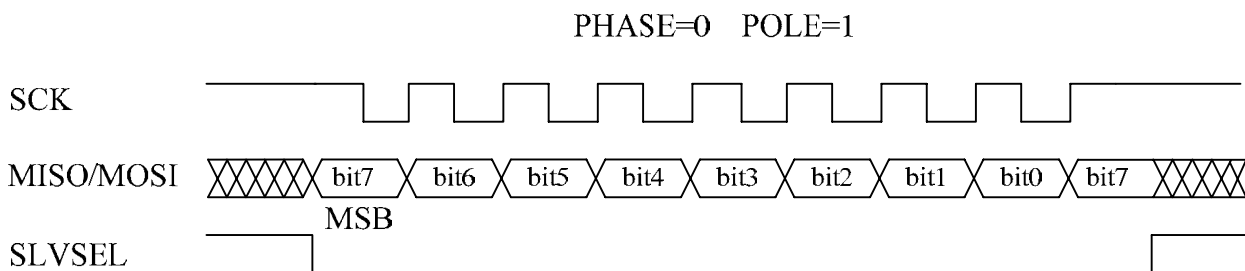

Figure 2-8 SPI Data Transfer Format (PHASE=0, POLCK=1)

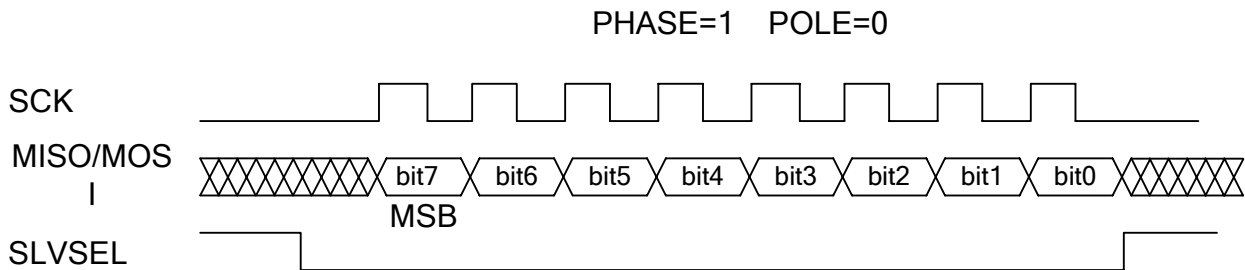

Figure 2-9 SPI Data Transfer Format (Phase=1, POLCK=0)

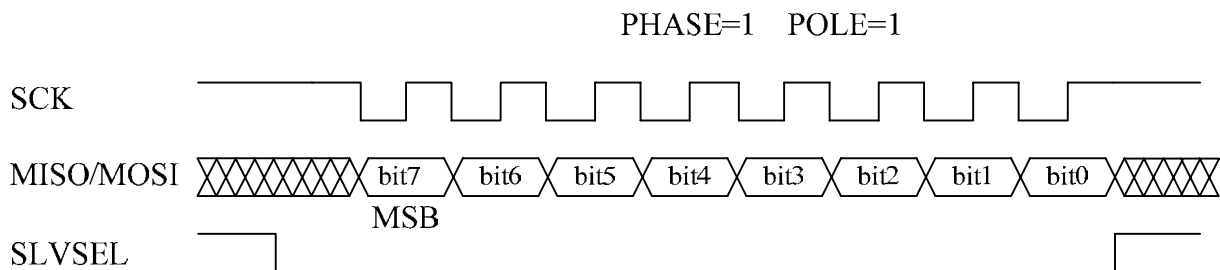

Figure 2-10 SPI Data Transfer Format (Phase=1, POLCK=1)

SPI can be configured into either Master or Slave mode via the MAS bit of the SPI0CON register. When in the Master mode, the SPI needs to supply the data clock, whose frequency relationship with the Master clock can be set by CLKDVD bits of the SPI0CON register. When it is configured in the Slave mode, the clock, SCK, is supplied by the external Master. The maximum data clock

frequency must not be higher than  $\frac{F_{mclk}}{8}$ .

SPI Interface Timing Characteristics is shown in the following Figure2-11, Figure2-12, Figure2-13, Figure2-14 and Table 2-3.

PHASE=0

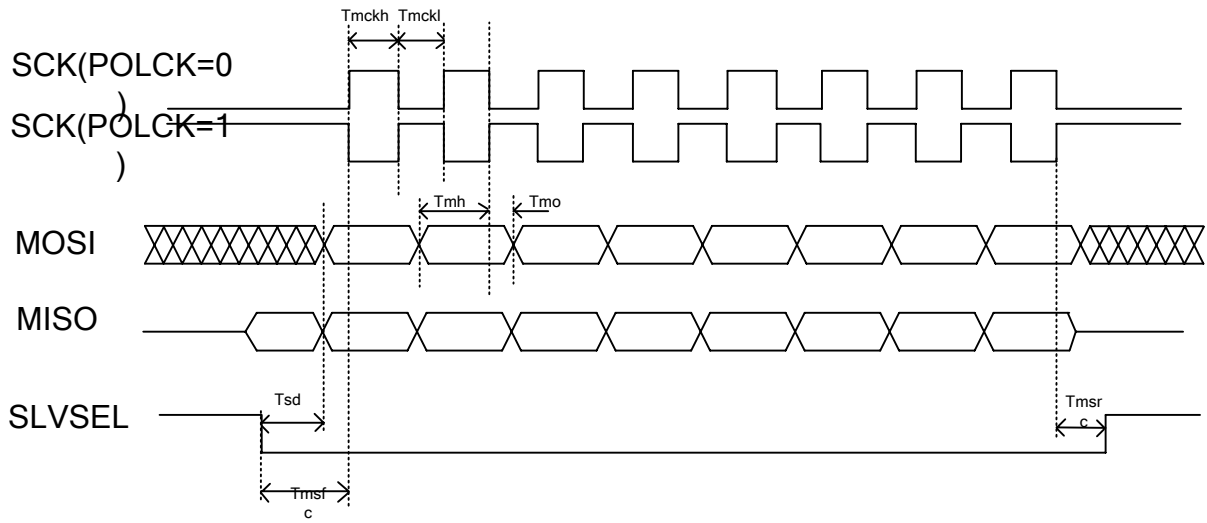

Figure 2-11 SPI master Timing PHASE =0

PHASE=1

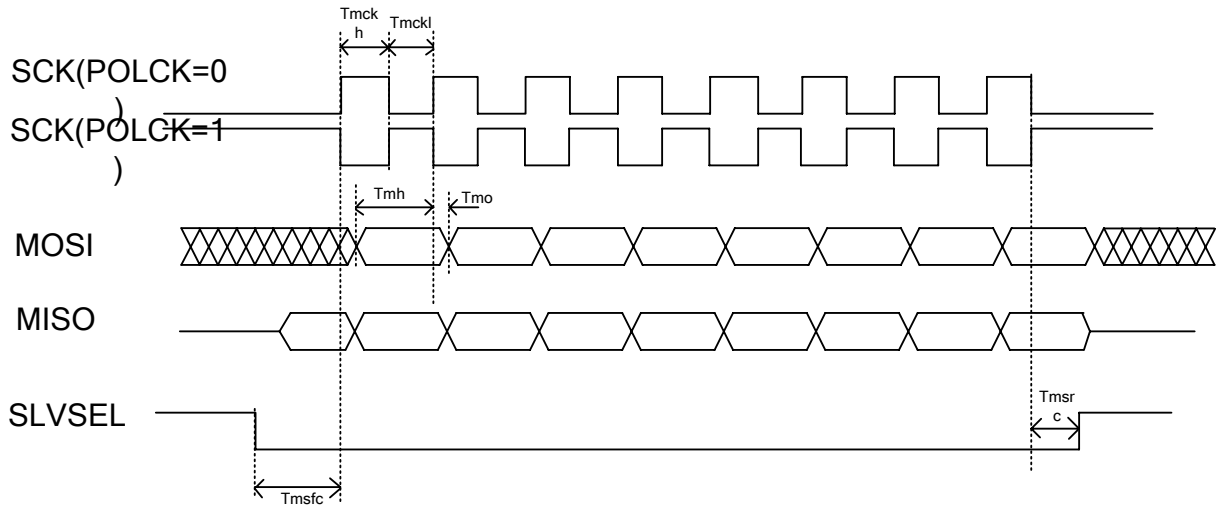

Figure 2-12 SPI master Timing PHASE =1



PHASE=0

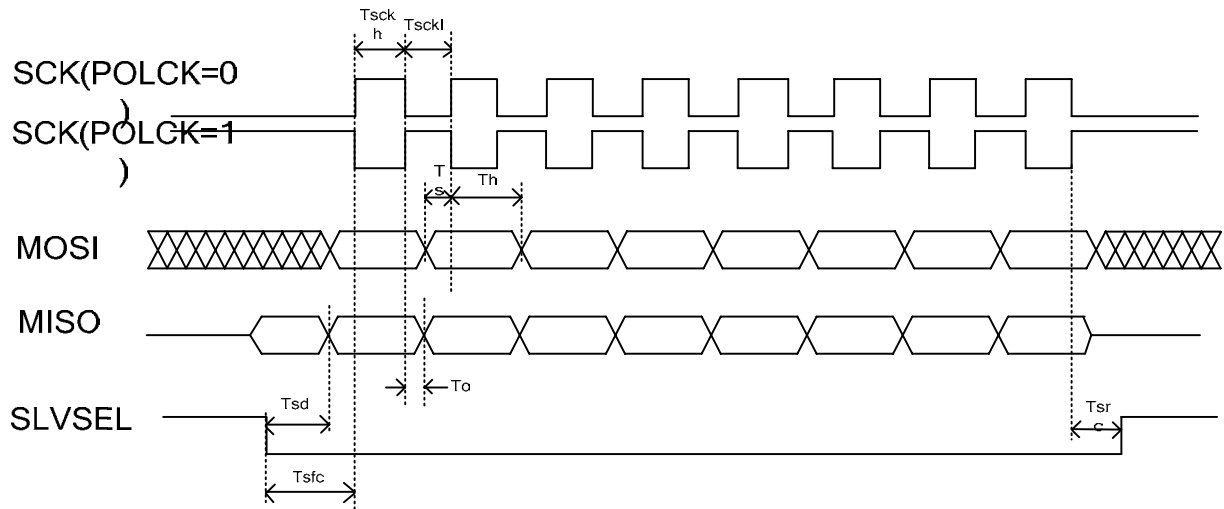

Figure 2-13 SPI slave Timing PHASE = 0

PHASE=1

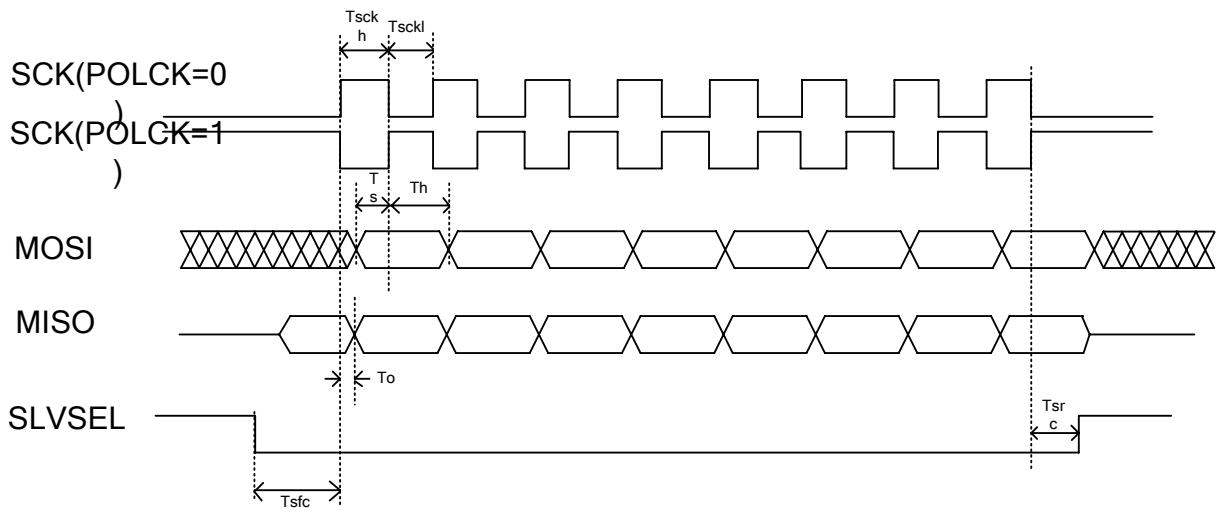

Figure 2-14 SPI slave Timing PHASE = 1

Table 2-3 SPI Timing Parameters

Parameter	Description	Min	Max	Units
Master Mode timing (see figure 2-11,2-12)				
Tmckh	sck high time	$4 \times Tsysclk$	--	ns
Tmckl	sck low time	$4 \times Tsysclk$	--	ns
Tmo	sck shift edge to mosi data change	0	--	ns
Tmh	mosi data valid to sck shift edge	$3 \times Tsysclk$	--	ns
Tsd	slvsel falling edge to mosi data valid	$4 \times Tsysclk$	--	ns
Tsf	slvsel falling edge to first sck edge	$(Tmckh+Tmckl)/2$	--	ns

Tmsrc	last sck edge to slvsel rising edge	$(Tmckh+Tmckl)/2$	--	ns
Slave mode timing(See figure 2-13,2-14)				
Tsckh	sck high Time	$4 \times Tsysclk$	--	ns
Tsckl	sck low Time	$4 \times Tsysclk$	--	ns
Tsd	slvsel falling edge to Miso valid data time	0	$4 \times Tsysclk$	ns
Ts	Mosi Data valid to sck sample edge	0	--	ns
Th	sck sample edge to Mosi data change	$4 \times Tsysclk$	--	ns
To	sck shift edge to Miso data change	0	$4 \times Tsysclk$	ns
Tsfc	slvsel falling edge to first sck edge	$4 \times Tsysclk$	--	ns
Tsrc	last sck edge to slvsel rising edge	$4 \times Tsysclk$	--	ns
*Tsysclk is equal to one period of the device system clock				

### 3 ELECTRICAL SPECIFICATIONS

#### 3.1 Absolute Maximum Ratings

**Table 3-1 Absolute Maximum Ratings**

Item	Symbol	Unit	Value	Note
Power Supply Voltage 1	VDDA - VSSA	V	-0.3 ~ +3.6	1, 2
Power Supply Voltage 2	VDD3 - VSS	V	-0.3 ~ +3.6	1, 3
I/O Power Supply Voltage	Vt	V	-0.3 ~ IOVCC + 0.3	1,4
Operating Temperature	Topr	°C	-40 ~ +85	1
Storage Temperature	Tstg	°C	-55 ~ +125	1

Notes

- 1.If used beyond the absolute maximum ratings, FT5x06 may be permanently damaged. It is strongly recommended that the device be used within the electrical characteristics in normal operations. If exposed to the condition not within the electrical characteristics, it may affect the reliability of the device.
- 2.Make sure VDDA(high)≥VSSA (low)
- 3.Make sure VDD (high)≥VSS (low)
- 4.IOVCC is set to VDD3 or VDDD by software configuration.

**3.2 DC Characteristics**
**Table 3-2 DC Characteristics (VDDA=VDD3=2.8~3.6V, Ta=-40~85°C)**

Item	Symbol	Unit	Test Condition	Min.	Typ.	Max.	Note
Input high-level voltage	VIH	V		0.7 x IOVCC	--	IOVCC	
Input low -level voltage	VIL	V		-0.3	--	0.3 x IOVCC	
Output high -level voltage	VOH	V	IOH=-0.1mA	0.7 x IOVCC	--	--	
Output low -level voltage	VOL	V	IOH=0.1mA	--	--	0.3 x IOVCC	
I/O leakage current	ILI	μA	Vin=0~VDDA	-1	--	1	
Current consumption ( Normal operation mode )	Iopr	mA	VDDA=VDD3 = 2.8V Ta=25°C MCLK=24MHz	--	6	--	
Current consumption ( Monitor mode )	Imon	mA	VDDA=VDD3 = 2.8V Ta=25°C MCLK=24MHz	--	4	--	
Current consumption ( Sleep mode )	Islp	mA	VDDA=VDD3 = 2.8V Ta=25°C MCLK=24MHz	--	0.03	--	
Step-up output voltage	VDD5	V	VDDA=VDD3= 2.8V	5	5.25	5.6	
Power Supply voltage	VDDA VDD3	V		2.7	2.8~3.6	3.7	

**3.3 AC Characteristics**
**Table 3-3 AC Characteristics of Oscillators**

Item	Symbol	Unit	Test Condition	Min.	Typ.	Max.	Note
OSC clock 1	fosc1	MHz	VDD3 = 2.8V Ta=25°C	43	48	52	
OSC clock 2	fosc2	KHz	VDD3 = 2.8V Ta=25°C	29	32	36	

**Table 3-4 AC Characteristics of TX & RX**

Item	Symbol	Unit	Test Condition	Min	Typ	Max	Note
TX acceptable clock	ftx	KHz		100	150	270	
TX output rise time	Ttxr	nS		--	20	--	
TX output fall time	Ttxf	nS		--	20	--	
RX input voltage	Trxi	V		1.2	--	1.6	

3.4 I/O Ports Circuits

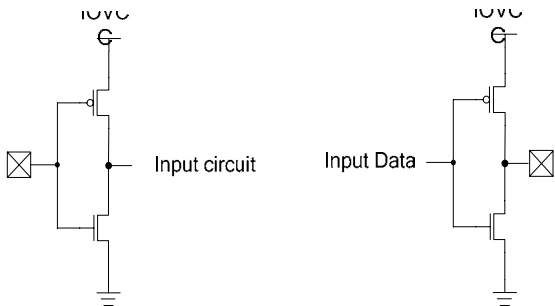

Figure 3-1 Digital Input & Output Port Circuits

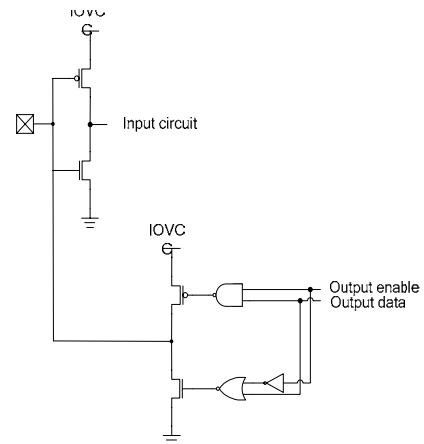

Figure 3-2 Digital In/Out Port Circuit

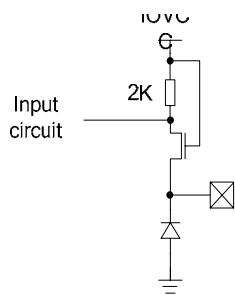

Figure 3-3 Reset Input Port Circuits

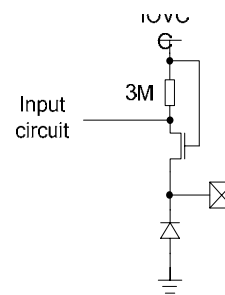

Figure 3-4 Wake Input Port Circuits

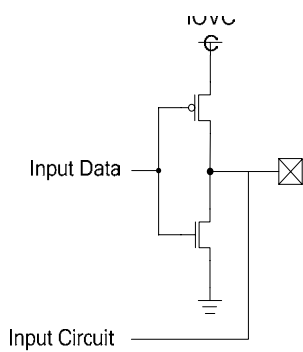

Figure 3-5 INT output Port Circuits

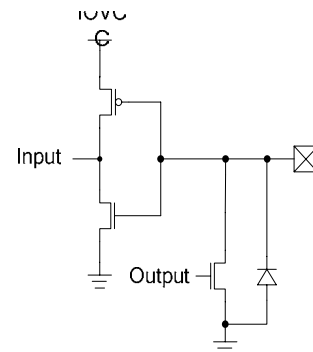

Figure 3-6 SCL/SDA Port Circuits

**3.5 POWER ON/Reset/Wake Sequence**

The GPIO such as Wake, INT and I2C should be pulled down to be low before powering on. The signal of waking up should be set to be high after powering on. INT signal will be sent to the host after initializing all parameters and then start to report points to the host.

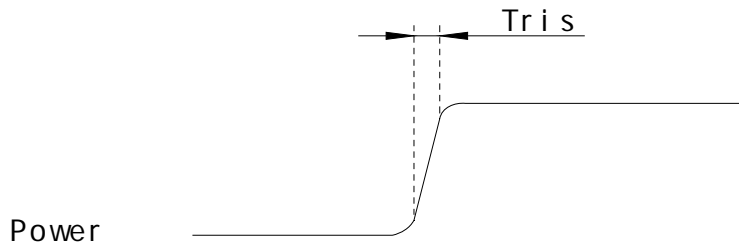

Figure 3-7 Power on time

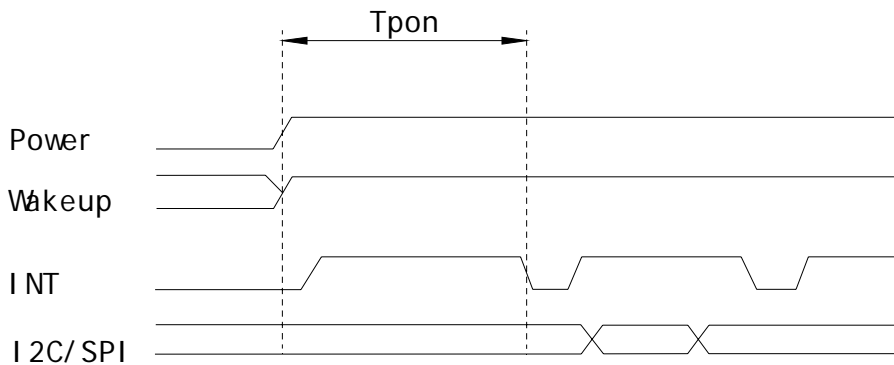

Figure 3-8 Power on Sequence

Reset time must be enough to guarantee reliable reset, The time of starting to report point after resetting approach to the time of starting to report point after powering on.

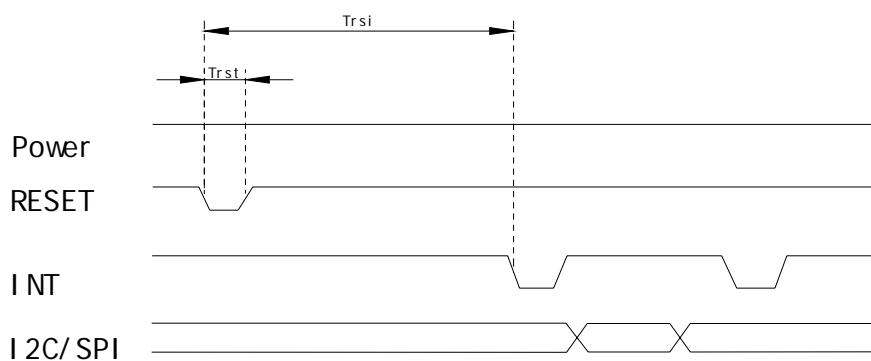

Figure 3-8 Reset Sequence

Wake time must be enough to wake up the system, The time of starting to report point after waking approach to the time of starting to report point after powering on

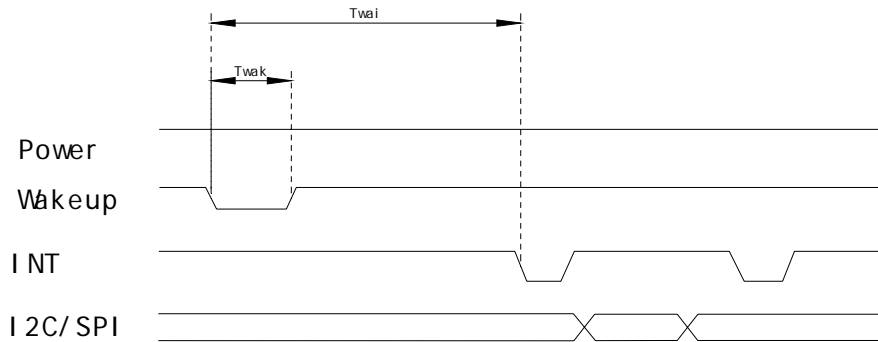

Figure 3-8 Wake Sequence

**Table 3-5 Power on/Reset/Wake Sequence Parameters**

Parameter	Description	Min	Max	Units
Tris	Rise time from 0.1VDD to 0.9VDD	--	10	ms
Tpon	Time of starting to report point after powering on	300	--	ms
Trsi	Time of starting to report point after resetting	300	--	ms
Trst	Reset time	5	--	ms
Twai	Time of starting to report point after waking	300	--	ms
Twak	Wake up time	5	--	ms

#### 4 PIN CONFIGURATIONS

Pin List of FT5x06

**Table 4-1 Pin Definition of FT5x06**

Name	Pin No.			Type	Description
	FT5206GE1	FT5306DE4	FT5406EE8		
VSSA	40	1	1	PWR	Analog ground
NC	1	2	2		Not connected
NC		48	3		Not connected
TX28			4	O	Transmit output pin
TX27			5	O	Transmit output pin
TX26			6	O	Transmit output pin
TX25			7	O	Transmit output pin
TX24			8	O	Transmit output pin
TX23			9	O	Transmit output pin
TX22			10	O	Transmit output pin
TX21			11	O	Transmit output pin
TX20		3	12	O	Transmit output pin
TX19		4	13	O	Transmit output pin
TX18		5	14	O	Transmit output pin
TX17		6	15	O	Transmit output pin
TX16		7	16	O	Transmit output pin
TX15	2	8	17	O	Transmit output pin
TX14	3	9	18	O	Transmit output pin

TX13	4	10	19	O	Transmit output pin
TX12	5	11	20	O	Transmit output pin
TX11	6	12	21	O	Transmit output pin
TX10	7	13	22	O	Transmit output pin
TX9	8	14	23	O	Transmit output pin
TX8	9	15	24	O	Transmit output pin
TX7	10	16	25	O	Transmit output pin
TX6	11	17	26	O	Transmit output pin
TX5	12	18	27	O	Transmit output pin
TX4	13	19	28	O	Transmit output pin
TX3	14	20	29	O	Transmit output pin
TX2	15	21	30	O	Transmit output pin
TX1	16	22	31	O	Transmit output pin
VDD5	17	23	32	PWR	internal generated 5V power supply , A 1 $\mu$ F ceramic capacitor to ground is required.
VDD3	18	24	33	PWR	Analog power supply
VSS	19	25	34	PWR	Analog ground
VDDD	20	26	35	PWR	Digital power supply (1.8V), generated internal. A 1 $\mu$ F ceramic capacitor to ground is required.
TEST_EN	21	27	36	I	Test mode enabled at high and float in normal mode
GPIO0			37	I/O	General Purpose Input/Output port
GPIO1			38	I/O	General Purpose Input/Output port
GPIO2			39	I/O	General Purpose Input/Output port
GPIO3			40	I/O	General Purpose Input/Output port
SSEL/SCL	22	28	41	I/O	SPI Slave mode, chip select, active low / I2C clock input
SCK	23	29	42	I	SPI Slave mode, clock input
MOSI/SDA	24	30	43	I/O	SPI Slave mode, data input / I2C data input and output
MISO	25	31	44	O	SPI Slave mode, data output
/RST	26	32	45	I	External Reset, Low is active
WAKE	27	33	46	I	External interrupt from the host
INT	28	34	47	O	External interrupt to the host
NC			48		Not connected
NC			49		Not connected
NC			50		Not connected
NC			51		Not connected
VDDA	30	35	52	PWR	Analog power supply
RX1	29	36	53	I	Receiver input pins
RX2	31	37	54	I	Receiver input pins
RX3	32	38	55	I	Receiver input pins
RX4	33	39	56	I	Receiver input pins
RX5	34	40	57	I	Receiver input pins
RX6	35	41	58	I	Receiver input pins
RX7	36	42	59	I	Receiver input pins
RX8	37	43	60	I	Receiver input pins
RX9	38	44	61	I	Receiver input pins
RX10	39	45	62	I	Receiver input pins

RX11		46	63	I	Receiver input pins
RX12		47	64	I	Receiver input pins
RX13			65	I	Receiver input pins
RX14			66	I	Receiver input pins
RX15			67	I	Receiver input pins
RX16			68	I	Receiver input pins

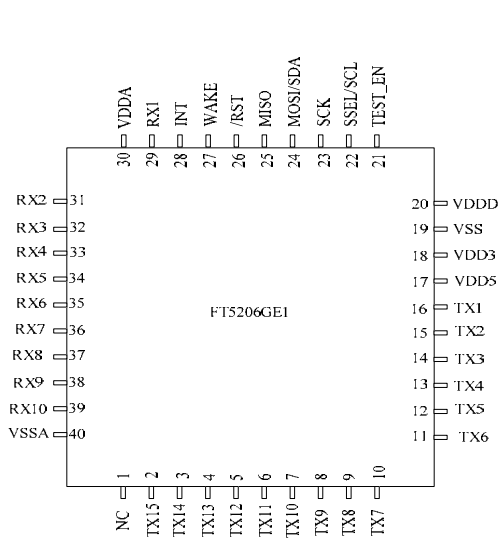

FT5206GE1 Package Diagram

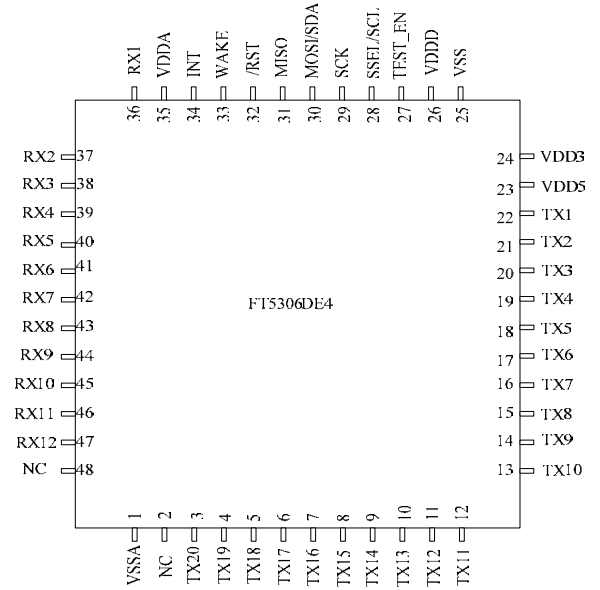

FT5306DE4 Package Diagram

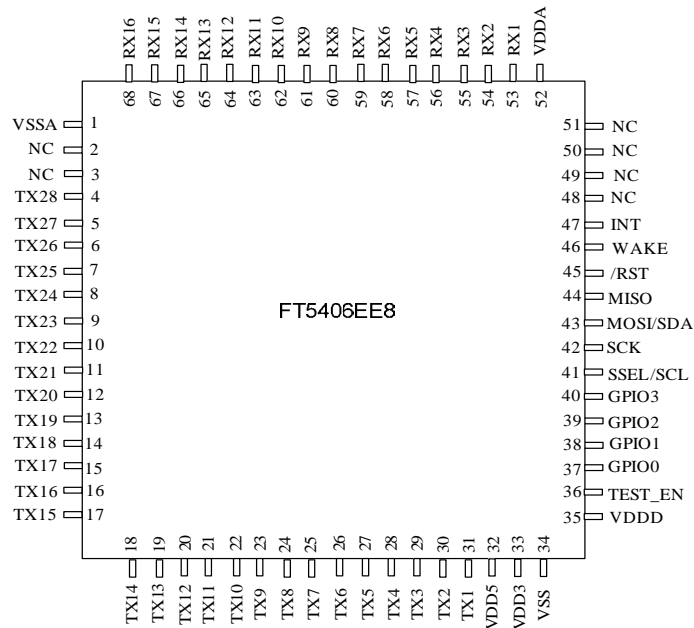

FT5406EE8 Package Diagram



5 PACKAGE INFORMATION

5.1 Package Information of QFN-5x5-40L Package

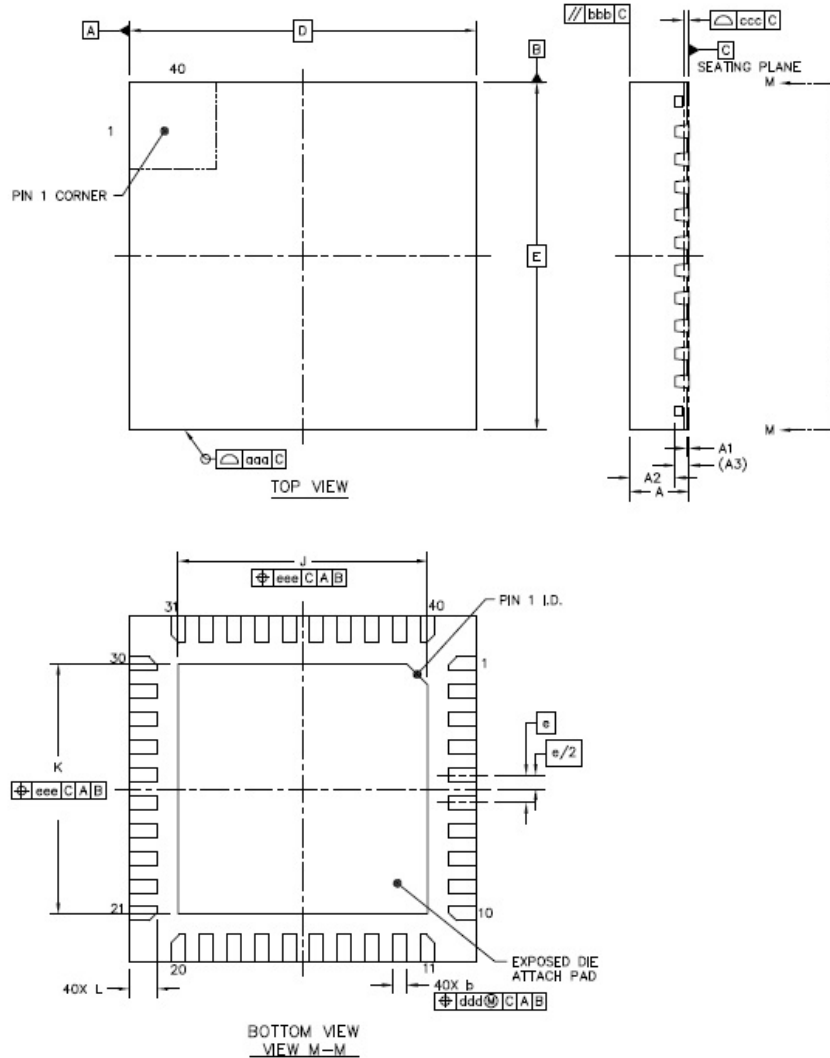

Item	Symbol	Millimeter		
		Min	Typ	Max
Total Thickness	A	0.7	0.75	0.8
Stand Off	A1	0	0.035	0.05
Mold Thickness	A2	----	0.55	0.57
L/F Thickness	A3	0.203 REF		
Lead Width	b	0.15	0.20	0.25
Body Size	D	5 BSC		
	E	5 BSC		
Lead Pitch	e	0.4 BSC		
EP Size	J	3.5	3.6	3.7
	K	3.5	3.6	3.7
Lead Length	L	0.35	0.4	0.45
Package Edge Tolerance	aaa	0.1		
Mold Flatness	bbb	0.1		
Co Planarity	ccc	0.08		
Lead Offset	ddd	0.1		
Exposed Pad Offset	eee	0.1		

5.2 Package Information of QFN-6x6-48L Package

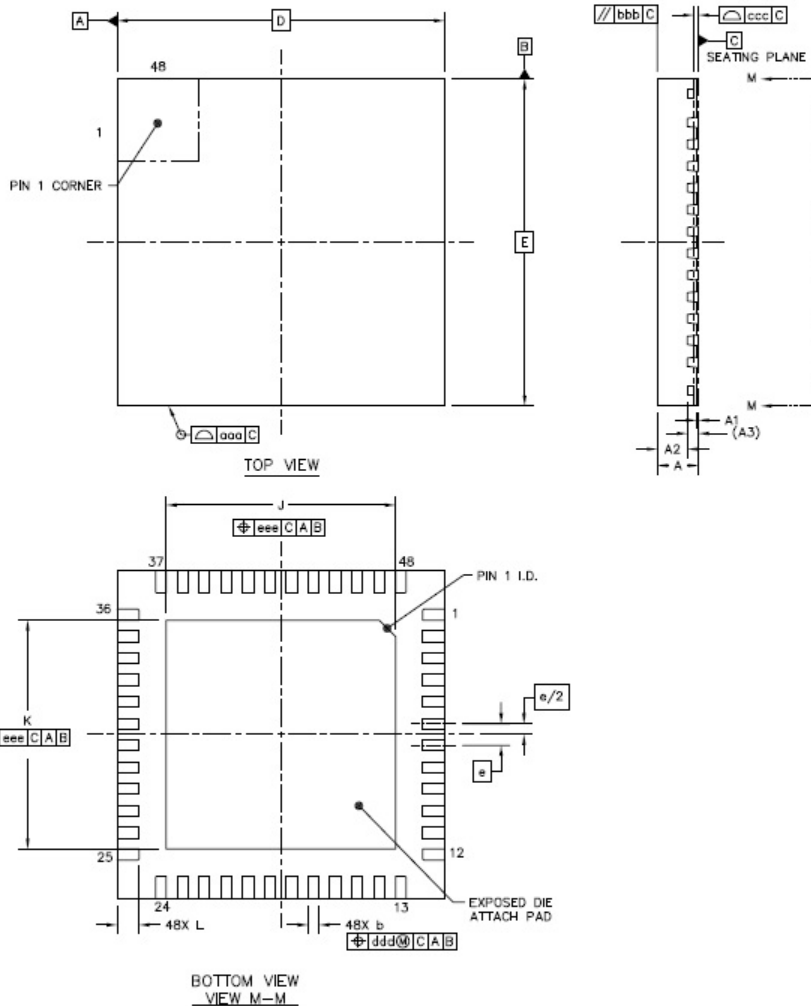

Item	Symbol	Millimeter		
		Min	Typ	Max
Total Thickness	A	0.7	0.75	0.8
Stand Off	A1	0	0.035	0.05
Mold Thickness	A2	----	0.55	0.57
L/F Thickness	A3	0.203 REF		
Lead Width	b	0.15	0.20	0.25
Body Size	D	6 BSC		
	E	6 BSC		
Lead Pitch	e	0.4 BSC		
EP Size	J	4.1	4.2	4.3
	K	4.1	4.2	4.3
Lead Length	L	0.35	0.4	0.45
Package Edge Tolerance	aaa	0.1		
Mold Flatness	bbb	0.1		
Co Planarity	ccc	0.08		
Lead Offset	ddd	0.1		
Exposed Pad Offset	eee	0.1		

5.3 Package Information of QFN-8x8-68L Package

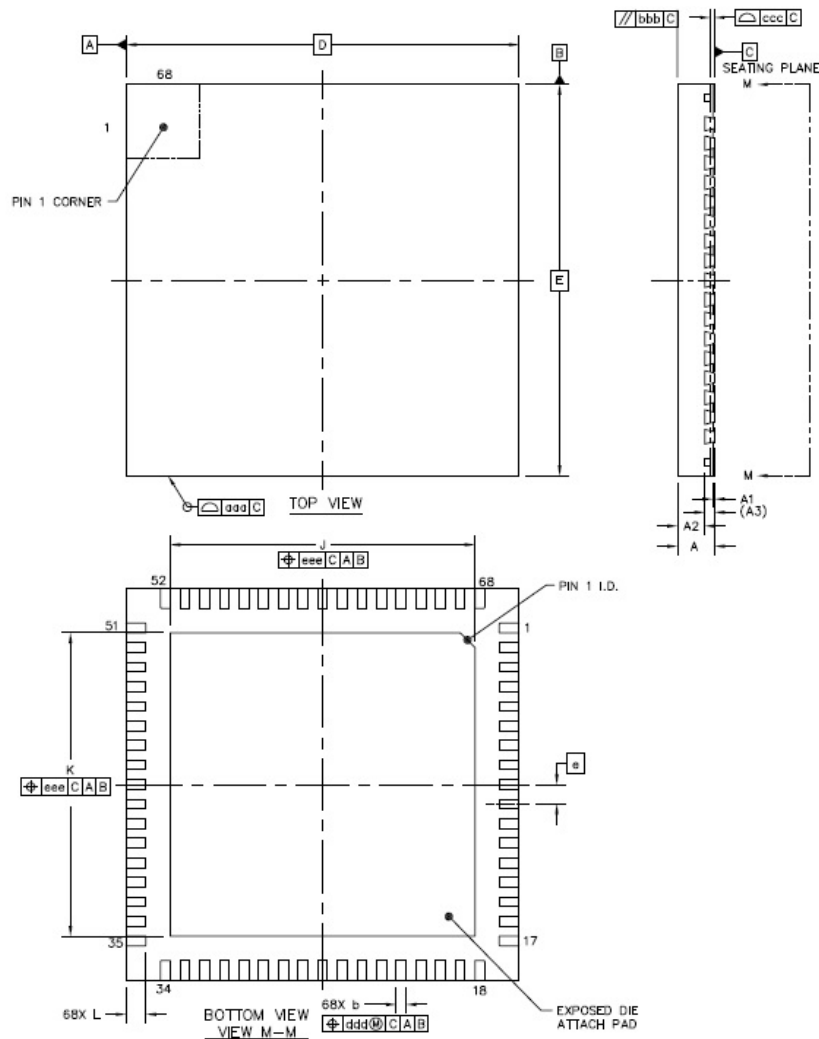

Item Name	Symbol	Millimeter		
		Min	Typ	Max
Total Thickness	A	0.7	0.75	0.8
Stand Off	A1	0	0.035	0.05
Mold Thickness	A2	----	0.55	0.57
L/F Thickness	A3	0.203 REF		
Lead Width	b	0.15	0.20	0.25
Body Size	D	8 BSC		
	E	8 BSC		
Lead Pitch	e	0.4 BSC		
EP Size	J	6.1	6.2	6.3
	K	6.1	6.2	6.3
Lead Length	L	0.35	0.4	0.45
Package Edge Tolerance	aaa	0.1		
Mold Flatness	bbb	0.1		
Coplanarity	ccc	0.08		
Lead Offset	ddd	0.1		
Exposed Pad Offset	eee	0.1		

**5.4 Order Information**

<b>Package Type</b>	<b>QFN</b>
	<b>40Pin(5 * 5)/48Pin( 6 * 6 )/68Pin ( 8 * 8 )</b>
	<b>0.75 - P0.4</b>
<b>Product Name</b>	<b>FT5206GE1/ FT5306DE4/FT5406EE8</b>

**Note:**

- 1). The last two letters in the product name indicate the package type and lead pitch and thickness.
- 2). The second last letter indicates the package type.  
**D**: QFN-6\*6, **E**: QFN-8\*8, **G**: QFN-5\*5
- 3). The last letter indicates the lead pitch and thickness.  
**E**: 0.75 - P0.4

**T: Track Code**

**F: "F" for Lead Free process.**

**Y: Year Code**

**WW: Week Code**

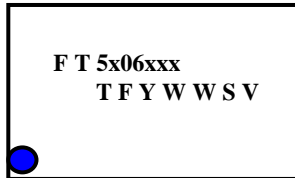

<b>Product Name</b>	<b>Package Type</b>	<b># TX Pins</b>	<b># RX Pins</b>
<b>FT5206GE1</b>	<b>QFN-40L</b>	<b>15</b>	<b>10</b>
<b>FT5306DE4</b>	<b>QFN-48L</b>	<b>20</b>	<b>12</b>
<b>FT5406EE8</b>	<b>QFN-68L</b>	<b>28</b>	<b>16</b>

**REVISION HISTORY**

<b>DDCN#</b>	<b>Version</b>	<b>Revisions</b>	<b>Date</b>
DC-1006004	<b>0.1</b>	<b>First draft</b>	<b>2010-06-11</b>
DC-1006006	<b>0.2</b>	<b>Change FT5206GE1 Package Diagram</b>	<b>2010-06-21</b>
DC-1012001	<b>0.3</b>	<b>Modify block figure, timing and I/O figure</b>	<b>2010-12-20</b>

END OF DATASHEET

	Confidential	

### Application Note for CTPM

Application Note for CTPM	
Project name	Touch panel
Document ref	[Document ref]
Version	0.8
Release date	18 Aug 2010
Owner	Xiaoxu Du
Classification	Confidential
Distribution List	[Distribution list]
Approval	

This document contains information proprietary to FocalTech Systems, Ltd., and may not be reproduced, disclosed or used in whole or part without the express written permission of FocalTech Systems, Ltd.

Copyright © 2010, FocalTech Systems, Ltd  
All rights reserved

R3-B4-A, South Area, Shenzhen Hi-Tech Industrial Park,  
Shenzhen, Gungdong, P.R. China  
ZIP :518057  
T +86 755 26588222  
F +86 755 26712499  
E [support@focaltech-systems.com](mailto:support@focaltech-systems.com)

## CTPM Application Note

### Revision History

Date	Version	List of changes	Author + Signature
18 Jan, 2010	0.1	Initial draft	Xiaoxu Du
17 Mar,2010	0.2	Add raw data protocol	Xiaoxu Du
22 Mar,2010	0.3	Add system information protocol	Xiaoxu Du
26 Mar,2010	0.4	Add calibration related parameters	Xiaoxu Du
08 May,2010	0.5	Add information to operating mode	Xinming Wang
07 Jul, 2010	0.6	Change Protocol and add information	Yunfeng Yuan
18 Aug, 2010	0.7	Modified to release version	Xiaoxu Du
22 Dec, 2010	0.8	Modify explanation for register 0xA4	Xiaoxu Du

# CTPM Application Note

## Table of Contents

1	I <sup>2</sup> C Interface .....	2
1.1	CTPM interface to Host .....	2
1.2	I <sup>2</sup> C Read/Write Interface description .....	2
1.3	Interrupt signal from CTPM to Host .....	3
1.4	Wakeup signal from Host to CTPM .....	4
2	CTP Register Mapping .....	4
2.1	Operating Mode .....	4
2.1.1	<i>DEVICE_MODE</i> .....	7
2.1.2	<i>GEST_ID</i> .....	7
2.1.3	<i>TD_STATUS</i> .....	8
2.1.4	<i>TOUCHn_XH (n:1-5)</i> .....	8
2.1.5	<i>TOUCHn_XL (n:1-5)</i> .....	8
2.1.6	<i>TOUCHn_YH (n:1-5)</i> .....	9
2.1.7	<i>TOUCHn_YL (n:1-5)</i> .....	9
2.1.8	<i>ID_G_THGROUP</i> .....	9
2.1.9	<i>ID_G_THPEAK</i> .....	9
2.1.10	<i>ID_G_THCAL</i> .....	9
2.1.11	<i>ID_G_THWATER</i> .....	9
2.1.12	<i>ID_G_THTEMP</i> .....	9
2.1.13	<i>ID_G_THDIFF</i> .....	10
2.1.14	<i>ID_G_CTRL</i> .....	10
2.1.15	<i>ID_G_TIMEENTERMONITOR</i> .....	10
2.1.16	<i>ID_G_PERIODACTIVE</i> .....	10
2.1.17	<i>ID_G_PERIODMONITOR</i> .....	10
2.1.18	<i>ID_G_AUTO_CLB_MODE</i> .....	10
2.1.19	<i>ID_G_LIB_VERSION_H</i> .....	11
2.1.20	<i>ID_G_LIB_VERSION_L</i> .....	11
2.1.21	<i>ID_G_CIPHER</i> .....	11
2.1.22	<i>ID_G_MODE</i> .....	11
2.1.23	<i>ID_G_PMODE</i> .....	11
2.1.24	<i>ID_G_FIRMWARE_ID</i> .....	11
2.1.25	<i>ID_G_STATE</i> .....	11
2.1.26	<i>ID_G_FT5201ID</i> .....	12
2.1.27	<i>ID_G_ERR</i> .....	12
2.1.28	<i>ID_G_CLB</i> .....	12
2.2	Test Mode .....	12
2.2.1	<i>DEVICE_MODE</i> .....	14
2.2.2	<i>ROW_ADDR</i> .....	14
2.2.3	<i>ROWDATAN_H</i> .....	14
2.2.4	<i>ROWDATAN_L</i> .....	15
2.3	System information Mode .....	16
2.3.1	<i>DEVICE_MODE</i> .....	17
2.3.2	<i>BIST_COMM</i> .....	17



## CTPM Application Note

2.3.3	<i>BIST_STAT</i> .....	17
2.3.4	<i>BL_VERH</i> .....	17
2.3.5	<i>BL_VERL</i> .....	18
2.3.6	<i>FTS_IC_VERH</i> .....	18
2.3.7	<i>FTS_IC_VERL</i> .....	18
2.3.8	<i>APP_IDH</i> .....	18
2.3.9	<i>APP_IDL</i> .....	18
2.3.10	<i>APP_VERH</i> .....	19
2.3.11	<i>APP_VERL</i> .....	19
2.3.12	<i>CID_n(n:0-4)</i> .....	19
3	CTPM Application Introduction .....	20
3.1	Standard Application information of FT5X06 .....	20
3.1.1	<i>Standard application circuit of FT5206GE1</i> .....	20
3.1.2	<i>Standard application circuit of FT5306DE4</i> .....	21
3.1.3	<i>Standard application circuit of FT5206EE8</i> .....	22
4	Communication between host and CTPM .....	22
4.1	Communication Contents .....	22
4.2	I2C Example Code .....	23

## CTPM Application Note

### Terminology

CTP – Capacitive touch panel

CTPM – Capacitive touch panel module

# 1 I<sup>2</sup>C Interface

## 1.1 CTPM interface to Host

Figure 1-1 shows how CTPM communicates with the Host, there are three kind of communication between CTPM and Host, we will introduce each communication in this section.

Transfer the data via I<sup>2</sup>C

Send interrupt when there is a valid touch

Host send Wakeup signal to CTPM

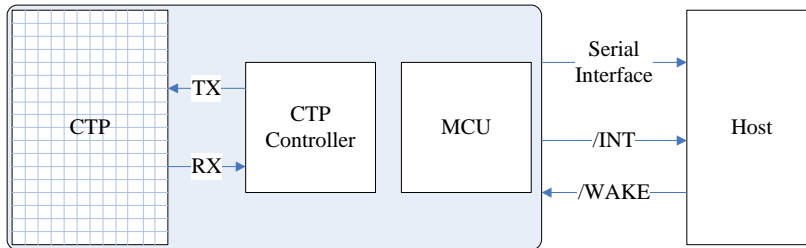

Figure 1-1 CTPM and Host connection

The Power Supply voltage of CTPM is 2.8V~3.3V, interface supply voltage is 2.8V~3.3V. There are Control Interface and Data Interface. As

Figure 1-1 demonstrates, Serial interface is the data interface, /INT and /WAKE are the control interface. For the detail, please refer to Table 1-1.

Table 1-1 Description for TP module and Host interface

Port Name	Voltage	Polar	Description
Serial interface	2.8~3.3V		Serial interface is for data transfer between Host and CTPM. CTPM support both I2C and SPI interface
/INT	2.8~3.3V	LOW	The interrupt from the CTPM to the Host
/WAKE*	2.8~3.3V	LOW	Wakeup signal from host to the CTPM

## 1.2 I<sup>2</sup>C Read/Write Interface description

Write N bytes to I2C slave

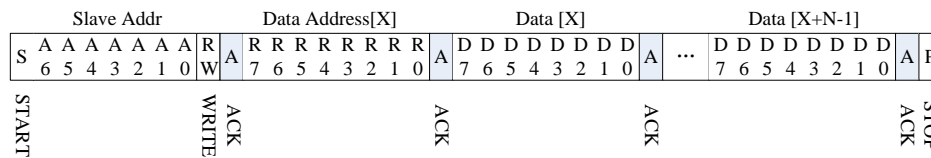

Set Data Address



## 1.4 Wakeup signal from Host to CTPM

Host can use the Wakeup Signal to wakeup the I<sup>2</sup>C slave device.

This pin should be connected to GND when flash programming while in normal running mode it should not be connected to GND.

## 2 CTP Register Mapping

This chapter describes the standard FTS Capacitive Touch Panel products communication registers in address order for each device mode. The most detailed descriptions of the Standard Products communication registers are in the Register Definitions section of each chapter. The device modes are listed in the table below, along with each mode's register prefix.

Device Mode	Prefix	Val	Description
Operating	Op	000b	Read touch point and gesture
Test	Te	100b	Read raw data
System Information	Sy	001b	Read system information related Reserved

### 2.1 Operating Mode

In this mode the CTP is fully functional as a touch screen controller. Read and write access address is just logical address which is not enforced by hardware or firmware. Here is the operating mode register map.

Operating Mode Register Map

Address	Name	Bit7	Bit6	Bit5	Bit4	Bit3	Bit2	Bit1	Bit0	Host Access
Op,00h	DEVIDE_MODE		Device Mode[2:0]							RW
Op,01h	GEST_ID	Gesture ID[7:0]								R
Op,02h	TD_STATUS					Number of touch points[3:0]				R
Op,03h	TOUCH1_XH	1 <sup>st</sup> Event Flag				1 <sup>st</sup> Touch X Position[11:8]				R
Op,04h	TOUCH1_XL	1 <sup>st</sup> Touch X Position[7:0]								R
Op,05h	TOUCH1_YH	1 <sup>st</sup> Touch ID[3:0]				1 <sup>st</sup> Touch Y Position[11:8]				R
Op,06h	TOUCH1_YL	1 <sup>st</sup> Touch Y Position[7:0]								R
Op,07h										
Op,08h										
Op,09h	TOUCH2_XH	2 <sup>nd</sup> Event				2 <sup>nd</sup> Touch				R

CTPM Application Note

		Flag		X Position[11:8]	
Op,0Ah	TOUCH2_XL	2 <sup>nd</sup> touch X Position[7:0]			R
Op,0Bh	TOUCH2_YH	2 <sup>nd</sup> Touch ID[3:0]		2 <sup>nd</sup> Touch Y Position[11:8]	R
Op,0Ch	TOUCH2_YL	2 <sup>nd</sup> Touch Y Position[7:0]			R
Op,0Dh					R
Op,0Eh					R
Op,0Fh	TOUCH3_XH	3 <sup>rd</sup> Event Flag		3 <sup>rd</sup> Touch X Position[11:8]	R
Op,10h	TOUCH3_XL	3 <sup>rd</sup> Touch X Position[7:0]			R
Op,11h	TOUCH3_YH	3 <sup>rd</sup> Touch ID[3:0]		3 <sup>rd</sup> Touch Y Position[11:8]	R
Op,12h	TOUCH3_YL	3 <sup>rd</sup> Touch Y Position[7:0]			R
Op,13h					R
Op,14h					R
Op,15h	TOUCH4_XH	4 <sup>th</sup> Event Flag		4 <sup>th</sup> Touch X Position[11:8]	R
Op,16h	TOUCH4_XL	4 <sup>th</sup> Touch X Position[7:0]			R
Op,17h	TOUCH4_YH	4 <sup>th</sup> Touch ID[3:0]		4 <sup>th</sup> Touch Y Position[11:8]	R
Op,18h	TOUCH4_YL	4 <sup>th</sup> Touch Y Position[7:0]			R
Op,19h					R
Op,1Ah					R
Op,1Bh	TOUCH5_XH	5 <sup>th</sup> Event Flag		5 <sup>th</sup> Touch X Position[11:8]	R
Op,1Ch	TOUCH5_XL	5 <sup>th</sup> Touch X Position[7:0]			R
Op,1Dh	TOUCH5_YH	5 <sup>th</sup> Touch ID[3:0]		5 <sup>th</sup> Touch Y Position[11:8]	R
Op,1Eh	TOUCH5_YL	5 <sup>th</sup> Touch Y Position[7:0]			R
Op,1Fh					R
Op,20h					R
Op,21h	Reserved				
...	...				
Op,7Fh	Reserved				
Op,80h	ID_G_THGROUP	valid touching detect threshold.			R/W
Op,81h	ID_G_THPEAK	valid touching peak detect threshold.			R/W

CTPM Application Note

Op,82h	ID_G_THCAL	the threshold when calculating the focus of touching.	R/W
Op,83h	ID_G_THWATER	the threshold when there is surface water.	R/W
Op,84h	ID_G_THTEMP	the threshold of temperature compensation.	R/W
Op,85h			R/W
Op,86h	ID_G_CTRL		Power control mode[1:0] R/W
Op,87h	ID_G_TIME_ENTER_MONITOR	The timer of entering monitor status	R/W
Op,88h	ID_G_PERIODACTIVE		Period Active[3:0] R/W
Op,89h	ID_G_PERIODMONITOR	The timer of entering idle while in monitor status	R/W
Op,8Ah			R/W
Op,8Bh			R/W
Op,8Ch			R/W
Op,8Dh			R/W
Op,8Eh			R/W
Op,8Fh			R/W
Op,90h			R/W
Op,91h			R/W
Op,92h			R/W
Op,93h			R/W
Op,94h			R/W
Op,95h			R/W
Op,96h			R/W
Op,97h			R/W
Op,98h			R/W
Op,99h			R/W
Op,9Ah			R/W
Op,9Bh			R/W
Op,9Ch			R/W
Op,9Dh			R/W
Op,9Eh			R/W
Op,9Fh			R/W
Op,A0h	ID_G_AUTO_CLB_MODE	auto calibration mode	R/W

Op,A1h	ID_G_LIB_VERSION_H	Firmware Library Version H byte	R
Op,A2h	ID_G_LIB_VERSION_L	Firmware Library Version L byte	R
Op,A3h	ID_G_CIPHER	Chip vendor ID	R
Op,A4h	ID_G_MODE	the interrupt status to host	R
Op,A5h	ID_G_PMODE	Power Consume Mode	
Op,A6h	ID_G_FIRMID	Firmware ID	R
Op,A7h	ID_G_STATE	Running State	
Op,A8h	ID_G_FT5201ID	CTPM Vendor ID	R
Op,A9h	ID_G_ERR	Error Code	R
Op,AAh	ID_G_CLB	Configure TP module during calibration in Test Mode	R/W
Op,ABh			R/W
Op,ACH			R/W
Op,ADh			R/W
Op,AEh	ID_G_B_AREA_TH	The threshold of big area	R/W
Op,AFh			R/W
...	...		
Op,FDh	Reserved		
Op,FEh	LOG_MSG_CNT	The log MSG count	R
Op,FFh	LOG_CUR_CHA	Current character of log message, will point to the next character when one character is read.	R

### 2.1.1 DEVICE\_MODE

This register is the device mode register, configure it to determine the current mode of the chip.

Address	Bit Address	Register Name	Description
Op,00h	6:4	Device Mode [2:0]	000b Normal operating Mode 001b System Information Mode (Reserved) 100b Test Mode – read raw data (Reserved)

### 2.1.2 GEST\_ID

This register describes the gesture of a valid touch.

Address	Bit Address	Register Name	Description
Op,01h	7:0	Gesture ID [7:0]	Gesture ID 0x10 Move UP



			0x14 Move Left 0x18 Move Down 0x1C Move Right 0x48 Zoom In 0x49 Zoom Out 0x00 No Gesture
--	--	--	---

### 2.1.3 TD\_STATUS

This register is the Touch Data status register.

Address	Bit Address	Register Name	Description
Op,02h	3:0	Number of touch points[3:0]	How many points detected. 1-5 is valid.
	7:4		

### 2.1.4 TOUCHn\_XH (n:1-5)

This register describes MSB of the X coordinate of the nth touch point and the corresponding event flag.

Address	Bit Address	Register Name	Description
Op,03h ~ Op,39h	7:6	Event Flag	00b: Put Down 01b: Put Up 10b: Contact 11b: Reserved
	5:4		Reserved
	3:0	Touch X Position [11:8]	MSB of Touch X Position in pixels

### 2.1.5 TOUCHn\_XL (n:1-5)

This register describes LSB of the X coordinate of the nth touch point.

Address	Bit Address	Register Name	Description
Op,04h ~ Op,3Ah	7:0	Touch X Position [7:0]	LSB of the Touch X Position in pixels

**2.1.6 TOUCH<sub>n</sub>\_YH (n:1-5)**

This register describes MSB of the Y coordinate of the nth touch point and corresponding touch ID.

Address	Bit Address	Register Name	Description
Op,05h	7:4	Touch ID[3:0]	Touch ID of Touch Point
~ Op,3Bh	3:0	Touch X Position [11:8]	MSB of Touch Y Position in pixels

**2.1.7 TOUCH<sub>n</sub>\_YL (n:1-5)**

This register describes LSB of the Y coordinate of the nth touch point.

Address	Bit Address	Register Name	Description
Op,06h	7:0	Touch X Position [7:0]	LSB of The Touch Y Position in pixels
~ Op,3Ch			

**2.1.8 ID\_G\_THGROUP**

This register describes valid touching detect threshold.

Address	Bit Address	Register Name	Description
Op,80h	7:0	ID_G_THGROUP	The actual value will be 4 times of the register's value. Default:280/4

**2.1.9 ID\_G\_THPEAK**

This register describes valid touching peak detect threshold.

Address	Bit Address	Register Name	Description
Op,81h	7:0	ID_G_THPEAK	Default:60

**2.1.10 ID\_G\_THCAL**

This register describes threshold when calculating the focus of touching.

Address	Bit Address	Register Name	Description
Op,82h	7:0	ID_G_THCAL	Default:16

**2.1.11 ID\_G\_THWATER**

This register describes threshold when there is surface water.

Address	Bit Address	Register Name	Description
Op,83h	7:0	ID_G_THWATER	Default:60

**2.1.12 ID\_G\_THTEMP**

This register describes threshold of temperature compensation.

Address	Bit Address	Register Name	Description
Op,84h	7:0	ID_G_THTEMP	Default:10

### 2.1.13 ID\_G\_THDIFF

This register describes threshold whether the coordinate is different from the original.

Address	Bit Address	Register Name	Description
Op,85h	7:0	ID_G_THDIFF	The actual value must be 32times of the register's value. Default :20

### 2.1.14 ID\_G\_CTRL

This register describes the run mode of microcontroller controlled by host

Address	Bit Address	Register Name	Description
Op,86h	0	ID_G_CTRL	0: not auto jump      1:auto jump

### 2.1.15 ID\_G\_TIMEENTERMONITOR

This register describes the time delay value when entering monitor status.

Address	Bit Address	Register Name	Description
Op,87h	7:0	ID_G_TIME ENTERMONITOR	Default :2

### 2.1.16 ID\_G\_PERIODACTIVE

This register describes the period of active status, it should not less than 12

Address	Bit Address	Register Name	Description
Op,88h	4:0	ID_G_PERIOD ACTIVE	Range form 3 to 14,default 12
	7:4		

### 2.1.17 ID\_G\_PERIODMONITOR

This register describes period of monitor status, it should not less than 30.

Address	Bit Address	Register Name	Description
Op,89h	7:0	ID_G_PERIOD MONITOR	Default:40

### 2.1.18 ID\_G\_AUTO\_CLB\_MODE

This register describes auto calibration mode.

Address	Bit Address	Register Name	Description
Op, A0h	7:0	ID_G_AUTO_	8'h 00: enable auto calibration

		CLB_MODE	8'h ff: disable auto calibration
--	--	----------	----------------------------------

### 2.1.19 ID\_G\_LIB\_VERSION\_H

This register describes library version high byte.

Address	Bit Address	Register Name	Description
Op, A1h	7:0	ID_G_LIB_VERSION_H	R: xx

### 2.1.20 ID\_G\_LIB\_VERSION\_L

This register describes library version low byte.

Address	Bit Address	Register Name	Description
Op, A2h	7:0	ID_G_LIB_VERSION_L	R: xx

### 2.1.21 ID\_G\_CIPHER

This register describes vendor's chip id.

Address	Bit Address	Register Name	Description
OP, A3h	7:0	ID_G_CIPHER	R: xx

### 2.1.22 ID\_G\_MODE

This register describes the interrupt status to host.

Address	Bit Address	Register Name	Description
Op,A4h	7:0	ID_G_MODE	0: Polling mode 1: Trigger mode

### 2.1.23 ID\_G\_PMODE

This register describes the power consumption mode of the TPM when in running status.

Address	Bit Address	Register Name	Description
Op,A5h	7:0	ID_G_PMODE	0: active 1: monitor 3: hibernate(deep sleep)

### 2.1.24 ID\_G\_FIRMWARE\_ID

This register describes the firmware id of the application.

Address	Bit Address	Register Name	Description
Op,A6h	7:0	ID_G_FIRMWARE_ID	R: xx

### 2.1.25 ID\_G\_STATE

This register is used to configure the run mode of TPM.

Address	Bit Address	Register Name	Description
---------	-------------	---------------	-------------

Op,A7h	7:0	ID_G_STATE	0: configure 1: work 2: calibration 3: factory 4: auto calibration
--------	-----	------------	--

### 2.1.26 ID\_G\_FT5201ID

This register describes vendor's chip id

Address	Bit Address	Register Name	Description
Op,A8h	7:0	ID_G_FT5201ID	R: xx

### 2.1.27 ID\_G\_ERR

This register describes the error code when the TPM is running.

Address	Bit Address	Register Name	Description
Op,A9h	7:0	ID_G_ERR	ERR Code 8'h00:OK 8'h03:chip register writing inconsistent with reading 8'h05:chip start fail 8'h1A:no match among the basic input(such as TX_ORDER) while calibration

### 2.1.28 ID\_G\_CLB

This register is used to configure the TPM when Calibration

Address	Bit Address	Register Name	Description
Op,AAh	7:0	ID_G_CLB	Mapping the Array of G_Bank1, total length is NUM_TX+NUM_RX+1. the array address increases 1 after every write.

## 2.2 Test Mode

In this mode, CTP will provide some panel related information. Host can get the following information in this mode

Raw data of touch panel

Panel configure related information

Test Mode Register Map

Address	Name	Bit7	Bit6	Bit5	Bit4	Bit3	Bit2	Bit1	Bit0	Host Access
Te,00h	DEVIDE_MODE	Data Read Toggle	Device Mode[2:0]							RW

CTPM Application Note

Te,01h	ROW_ADDR	The address of the row to be read	RW
Te,02h	START_SCAN	Start the scan command, the value stands for the scan frequency, will be set to zero when scan finishes	RW
Te,03h	ROW_NUM	Panel row number	RW
Te,04h	COL_NUM	Panel column number	RW
Te,05h	DRIVER_VOL	Driver voltage of chip	RW
Te,06h	START_RX	Setting the RX start number	RW
Te,07h	GAIN	Control the difference value for touching	RW
Te,08h	ORIGIN_XH	High byte of origin X coordinate	RW
Te,09h	ORIGIN_XL	Low byte of origin X coordinate	RW
Te,0Ah	ORIGIN_YH	High byte of origin Y coordinate	RW
Te,0Bh	ORIGIN_YL	Low byte of origin Y coordinate	RW
Te,0Ch	RES_WH	High byte of width of resolution	RW
Te,0Dh	RES_WL	Low byte of width of resolution	RW
Te,0Eh	RES_HH	High byte of height of resolution	RW
Te,0Fh	RES_HL	Low byte of height of resolution	RW
Te,10h	RAWDATA0_H	High byte of raw data 0	R
Te,11h	RAWDATA0_L	Low byte of raw data 0	R
Te,12h	RAWDATA1_H	High byte of raw data 1	R
Te,13h	RAWDATA1_L	Low byte of raw data 1	R
...	...	...	
Te,4Ah	RAWDATA29_H	High byte of raw data 29	R
Te,4Bh	RAWDATA29_L	Low byte of raw data 29	R
Te,4Ch	TH_POINT_NUM	Touch point number support	RW
Te,4Dh	Reserved		
Te,4Eh	Reserved		
Te,4Fh	Reserved		
Te,50h	TX_ORDER_0	TX Order, start from zero	RW
Te,51h	TX_ORDER_1		RW
...	...	...	RW
Te,77h	TX_ORDER_39		RW
Te,78h	ROW0_CAC	Charge Amplifier feedback Capacitance of ROW0	RW
Te,79h	ROW1_CAC	Charge Amplifier feedback Capacitance of ROW1	RW
...	...	...	
Te,9Fh	ROW39_CAC	Charge Amplifier feedback Capacitance of ROW39	RW

Te,A0h	COL0_CAC	Charge Amplifier feedback Capacitance of COL0		RW
...	...	...		
Te,BEh	COL29_CAC	Charge Amplifier feedback Capacitance of COL29		RW
Te,BFh	ROW0_1_OFFSET	Offset of ROW1	Offset of ROW0	RW
...	...	...	...	
Te,D2h	ROW38_39_OFFSET	Offset of ROW39	Offset of ROW38	RW
Te,D3h	COL0_1_OFFSET	Offset of COL1	Offset of COL0	RW
...	...	...	...	
Te,E1h	COL28_29_OFFSET	Offset of COL29	Offset of COL28	RW
...	...			
Te,FEh	LOG_MSG_CNT	The log MSG count		R
Te,FFh	LOG_CUR_CHA	Current character of log message, will point to the next character when one character is read.		R

### 2.2.1 DEVICE\_MODE

This register is the device mode register, configure it to determine the current mode of the chip.

Address	Bit Address	Register Name	Description
Te,00h	7	Data Read Toggle	This bit is toggled by the Host only when a data transfer between the Host and TrueTouch device requires register based handshaking.
	6:4	Device Mode[2:0]	000b Normal operating Mode 001b System Information Mode (Reserved) 100b Test Mode – read raw data (Reserved)

### 2.2.2 ROW\_ADDR

This register is the Touch Data status register.

Address	Bit Address	Register Name	Description
Te,01h	7:0	Row address	The address of the row to be read Please delay for more than 100us, then read the raw data

### 2.2.3 ROWDATAN\_H

This register is the Touch Data status register.

Address	Bit Address	Register Name	Description
Te,(10+2n)h	7:0	High byte of raw data N	High byte of raw data N

			If N exceeds the column number will return 0xff
--	--	--	---

### 2.2.4 ROWDATAN\_L

This register is the Touch Data status register.

Address	Bit Address	Register Name	Description
Te,(10+2n+1)h	7:0	Low byte of raw data N	Low byte of raw data N If N exceeds the column number will return 0xff



## 2.3 System information Mode

This mode provides access to all of the one-time system information. The system information is either written by the host to permanently configure the device (for example, power timers), or is written to the device at compile time for the host to read (for example, application version). To enter BIST (built in self test) mode write the BIST command required into the BIST\_COMM register.

Read and write access is theoretical and is not enforce by hardware or firmware. Words have their MSB at lower address.

System Information Mode Register Map

Address	Name	Bit7	Bit6	Bit5	Bit4	Bit3	Bit2	Bit1	Bit0	Host Access
Sy,00h	DEVIDE_MODE	Data Read Toggle	Device Mode[2:0]							RW
Sy,01h	BIST_COMM	BIST Command[7:0]								W
Sy,02h	BIST_STAT	BIST Status[7:0]								R
Sy,03h	Unused									
Sy,04h	Unused									
Sy,05h	Unused									
Sy,06h	Unused									
Sy,07h	UID_0	Unique Silicon ID #0[7:0]								R
Sy,08h	UID_1	Unique Silicon ID #1[7:0]								R
Sy,09h	UID_2	Unique Silicon ID #2[7:0]								R
Sy,0Ah	UID_3	Unique Silicon ID #3[7:0]								R
Sy,0Bh	UID_4	Unique Silicon ID #4[7:0]								R
Sy,0Ch	UID_5	Unique Silicon ID #5[7:0]								R
Sy,0Dh	UID_6	Unique Silicon ID #6[7:0]								R
Sy,0Eh	UID_7	Unique Silicon ID #7[7:0]								R
Sy,0Fh	BL_VERH	Bootloader version[15:8]								R
Sy,10h	BL_VERL	Bootloader version[7:0]								R
Sy,11h	FTS_IC_VERH	Focal Tech IC Version[15:8]								R
Sy,12h	FTS_IC_VERL	Focal Tech IC Version[7:0]								R
Sy,13h	APP_IDH	Application ID[15:8]								R
Sy,14h	APP_IDL	Application ID[7:0]								R
Sy,15h	APP_VERH	Application Version[15:8]								R
Sy,16h	APP_VERL	Application Version[7:0]								R
Sy,17h	Unused									
Sy,18h	Unused									

Sy,19h	Unused		
Sy,1Ah	Unused		
Sy,1Bh	CID_0	Custom ID #0[0:7]	R
Sy,1Ch	CID_1	Custom ID #1[0:7]	R
Sy,1Dh	CID_2	Custom ID #2[0:7]	R
Sy,1Eh	CID_3	Custom ID #3[0:7]	R
Sy,1Fh	CID_4	Custom ID #4[0:7]	R
...	...		
Sy,FEh	LOG_MSG_CNT	The log MSG count	R
Sy,FFh	LOG_CUR_CHA	Current character of log message, will point to the next character when one character is read.	R

### 2.3.1 DEVICE\_MODE

This register is the device mode register, configure it to determine the current mode of the chip.

Address	Bit Address	Register Name	Description
Sy,00h	6:4	Device Mode[2:0]	000b Normal operating Mode 001b System Information Mode (Reserved) 100b Test Mode – read raw data (Reserved)

### 2.3.2 BIST\_COMM

This register is the BIST command register. The BIST (built in self test) function to perform is set here.

Address	Bit Address	Register Name	Description
Sy,01h	7:0	BIST Command[7:0]	BIST command to perform.

### 2.3.3 BIST\_STAT

This register reports the status of BIST (built in self test) functions either in progress or the last function completed.

Address	Bit Address	Register Name	Description
Sy,02h	7:0	BIST Command[7:0]	Status of the last BIST function started.

### 2.3.4 BL\_VERH

This register contains the MSB of the bootloader version specified by the application.

Address	Bit Address	Register Name	Description
Sy,0Fh	7:0	Bootloader version[15:8]	R:xx

### 2.3.5 BL\_VERL

This register contains the LSB of the bootloader version specified by the application.

Address	Bit Address	Register Name	Description
Sy,10h	7:0	Bootloader version[7:0]	R:xx.

### 2.3.6 FTS\_IC\_VERH

This is the FTS IC version register. This register contains the MSB of the FTS IC version. The value is BCD value, for example

FT5201 – FTS\_IC\_VERH(0x52), FTS\_IC\_VERL(0x01)

FT5202 – FTS\_IC\_VERH(0x52), FTS\_IC\_VERL(0x02)

FT5206 – FTS\_IC\_VERH(0x52), FTS\_IC\_VERL(0x06)

FT5306 – FTS\_IC\_VERH(0x53), FTS\_IC\_VERL(0x06)

FT5406 – FTS\_IC\_VERH(0x54), FTS\_IC\_VERL(0x06)

Address	Bit Address	Register Name	Description
Sy,11h	7:0	Focal Tech IC version [15:8]	Focal Tech IC Version MSB

### 2.3.7 FTS\_IC\_VERL

This is the FTS IC version register. This register contains the MSB of the FTS IC version. The value is BCD value, for example

FT5201 – FTS\_IC\_VERH(0x52), FTS\_IC\_VERL(0x01)

FT5202 – FTS\_IC\_VERH(0x52), FTS\_IC\_VERL(0x02)

FT5206 – FTS\_IC\_VERH(0x52), FTS\_IC\_VERL(0x06)

FT5306 – FTS\_IC\_VERH(0x53), FTS\_IC\_VERL(0x06)

FT5406 – FTS\_IC\_VERH(0x54), FTS\_IC\_VERL(0x06)

Address	Bit Address	Register Name	Description
Sy,12h	7:0	Focal Tech IC version [7:0]	Focal Tech IC Version LSB

### 2.3.8 APP\_IDH

This is the application ID register. This register contains the MSB of the application ID. This value is set to designate the individual project.

Address	Bit Address	Register Name	Description
Sy,13h	7:0	Application Version [15:8]	R:xx

### 2.3.9 APP\_IDL

This is the application ID register. This register contains the MSB of the application ID. This value is set to designate the individual project.

Address	Bit Address	Register Name	Description
Sy,14h	7:0	Application Version [15:8]	R:xx

### 2.3.10 APP\_VERH

This is the application version register. This register contains the MSB of the application version. This value should be incremented on each internal or external release of the project.

Address	Bit Address	Register Name	Description
Sy,15h	7:0	Application Version [15:8]	R:xx

### 2.3.11 APP\_VERL

This is the application version register. This register contains the LSB of the application version. This value should be incremented on each internal or external release of the project.

Address	Bit Addr.	Reg. Name	Description
Sy,16h	7:0	Application Version [7:0]	R:xx

### 2.3.12 CID\_n(n:0-4)

These are Custom ID registers. These registers contain user defined Custom ID identifiers for the FT TPM.

Address	Bit Addr.	Reg. Name	Description
Sy,1Bh~1Fh	7:0	Application Version [7:0]	R:xx

### 3 CTPM Application Introduction

#### 3.1 Standard Application information of FT5X06

Figure3-1,Figure3-2,Figure3-3 demonstrate the typical FT5x06 application schematic. It consists of FT's Capacitive Touch Panel(CTP), FT5X06 chip, and some peripheral components. According to the size of CTPM, you can choose the numbers of TX and RX needed.

##### 3.1.1 Standard application circuit of FT5206GE1

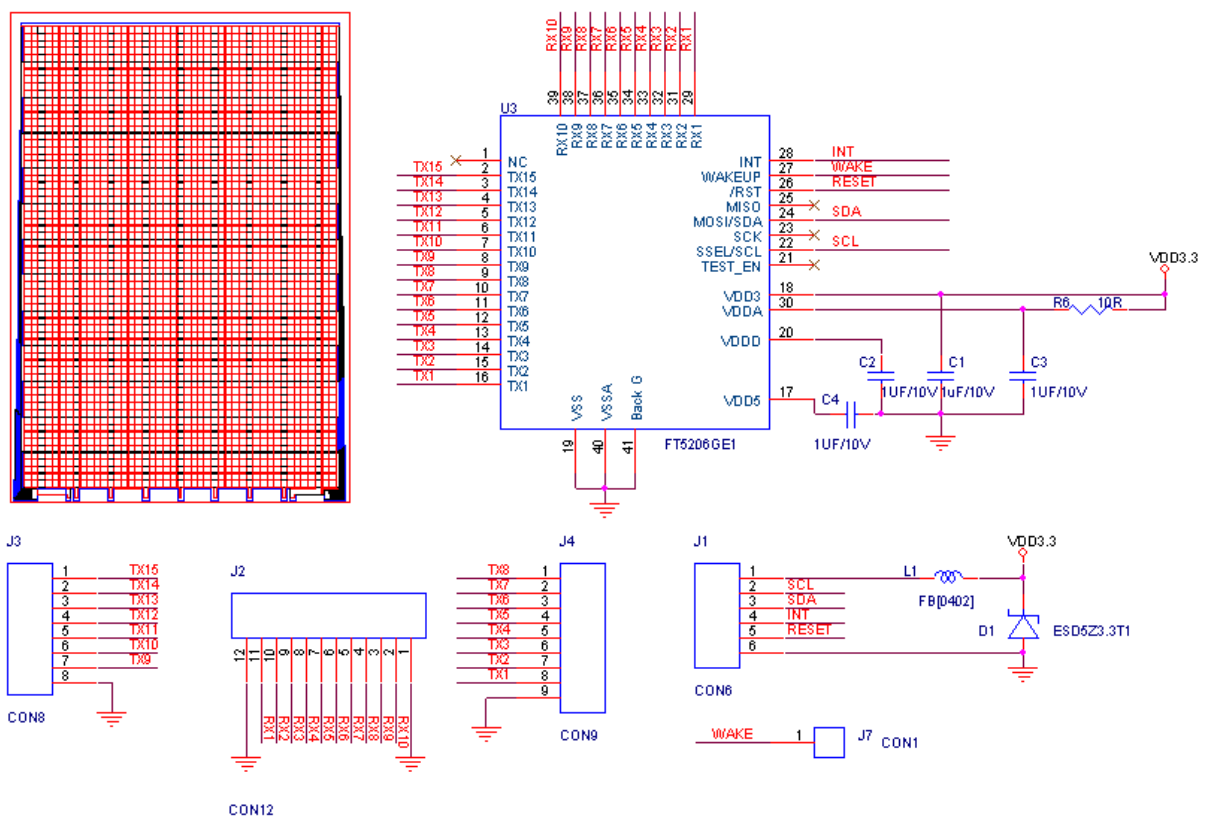

### 3.1.2 Standard application circuit of FT5306DE4

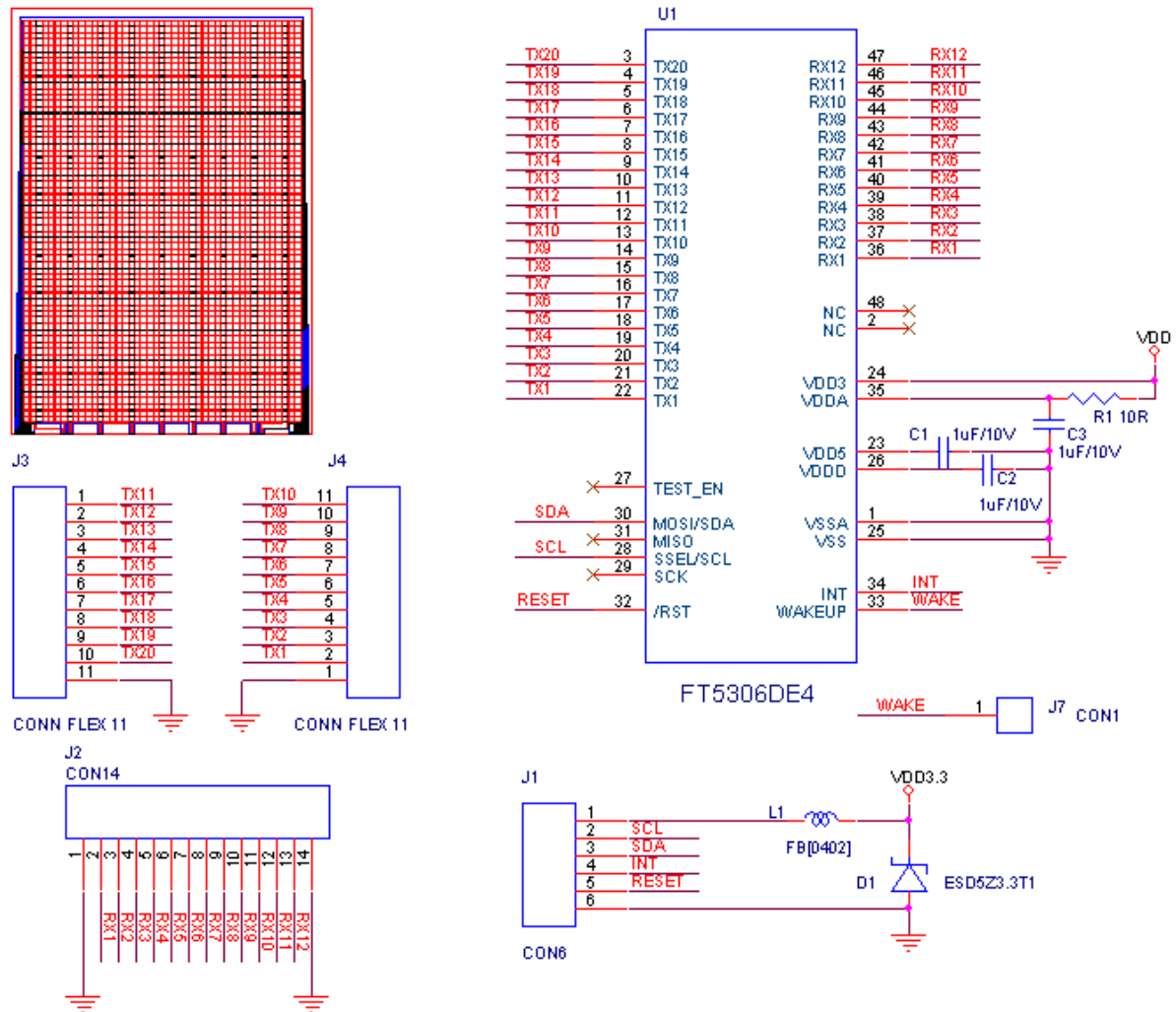

Figure 3-2 FT5306DE4 typical application schematic

### 3.1.3 Standard application circuit of FT5206EE8

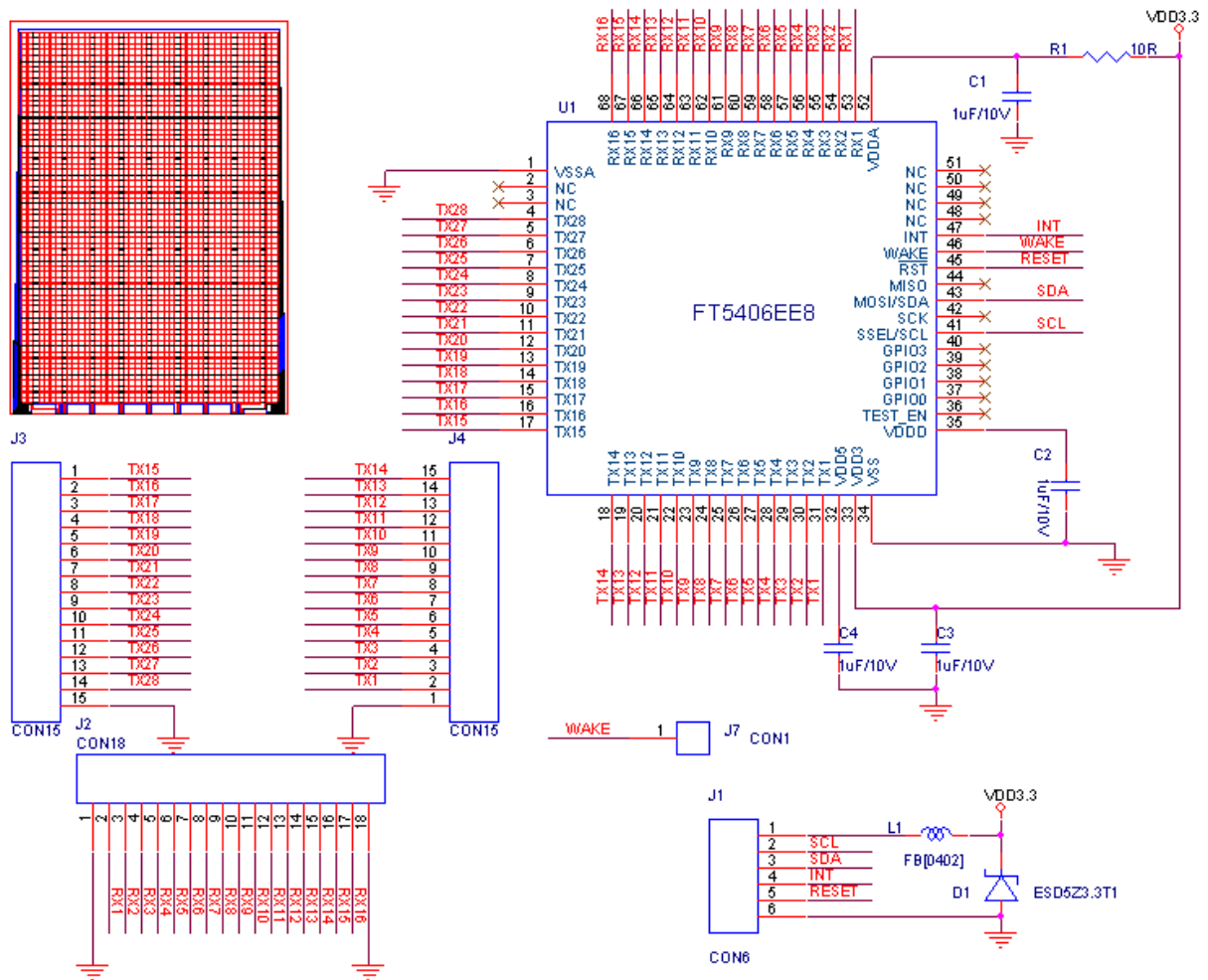

Figure 3-3 FT5406EE8 typical application schematic

## 4 Communication between host and CTPM

### 4.1 Communication Contents

The data Host received from the CTPM through serial interface are different depend on the configuration in Device Mode Register of the CTPM. Please refer to Section 2---CTP Register Mapping.

## 4.2 I2C Example Code

```

////////////////////////////////////
// I2C write bytes to device.
//
// Arguments: ucSlaveAdr - slave address
//            ucSubAdr - sub address
//            pBuf - pointer of buffer
//            ucBufLen - length of buffer
////////////////////////////////////
void i2cBurstWriteBytes(BYTE ucSlaveAdr, BYTE ucSubAdr, BYTE *pBuf, BYTE ucBufLen)
{
    BYTE ucDummy; // loop dummy
    ucDummy = I2C_ACCESS_DUMMY_TIME;
    while(ucDummy--)
    {
        if (i2c_AccessStart(ucSlaveAdr, I2C_WRITE) == FALSE)
            continue;
        if (i2c_SendByte(ucSubAdr) == I2C_NON_ACKNOWLEDGE) // check non-acknowledge
            continue;
        while(ucBufLen--) // loop of writting data
        {
            i2c_SendByte(*pBuf); // send byte
            pBuf++; // next byte pointer
        } // while
        break;
    } // while
    i2c_Stop();
}

////////////////////////////////////
// I2C read bytes from device.
//
// Arguments: ucSlaveAdr - slave address
//            ucSubAdr - sub address
//            pBuf - pointer of buffer
//            ucBufLen - length of buffer
////////////////////////////////////
void i2cBurstReadBytes(BYTE ucSlaveAdr, BYTE ucSubAdr, BYTE *pBuf, BYTE ucBufLen)
{
    BYTE ucDummy; // loop dummy

    ucDummy = I2C_ACCESS_DUMMY_TIME;
    while(ucDummy--)

```



## CTPM Application Note

```
{
    if (i2c_AccessStart(ucSlaveAdr, I2C_WRITE) == FALSE)
        continue;
    if (i2c_SendByte(ucSubAdr) == I2C_NON_ACKNOWLEDGE) // check non-acknowledge
        continue;
    if (i2c_AccessStart(ucSlaveAdr, I2C_READ) == FALSE)
        continue;
    while(ucBufLen--) // loop to burst read
    {
        *pBuf = i2c_ReceiveByte(ucBufLen); // receive byte
        pBuf++; // next byte pointer
    } // while
    break;
} // while
i2c_Stop();
}

////////////////////////////////////
// I2C read current bytes from device.
//
// Arguments: ucSlaveAdr - slave address
//            pBuf - pointer of buffer
//            ucBufLen - length of buffer
////////////////////////////////////
void i2cBurstCurrentBytes(BYTE ucSlaveAdr, BYTE *pBuf, BYTE ucBufLen)
{
    BYTE ucDummy; // loop dummy

    ucDummy = I2C_ACCESS_DUMMY_TIME;
    while(ucDummy--)
    {
        if (i2c_AccessStart(ucSlaveAdr, I2C_READ) == FALSE)
            continue;
        while(ucBufLen--) // loop to burst read
        {
            *pBuf = i2c_ReceiveByte(ucBufLen); // receive byte
            pBuf++; // next byte pointer
        } // while
        break;
    } // while
    i2c_Stop();
}
}
```

With collaboration of <https://www.displayfuture.com>