



MULTI-INNO TECHNOLOGY CO., LTD.

LCD MODULE SPECIFICATION

Model : MI0350AT

Revision	0.0
Engineering	
Date	
Our Reference	

1. GENERAL DESCRIPTION

The MI0350AT is a Color Active Matrix Liquid Crystal Display with Light Emission Diode(LED) backlight unit. The matrix employs a-Si Thin Film Transistor as the active element. It is a transmissive type display operating in the normally white mode. This module is a diagonal 3.5 inch with the portrait typed qVGA (240xRGBx320) resolution. Each pixel is divided into red, green and blue sub-pixels or dots which are arranged in vertical stripes.

Block Diagram

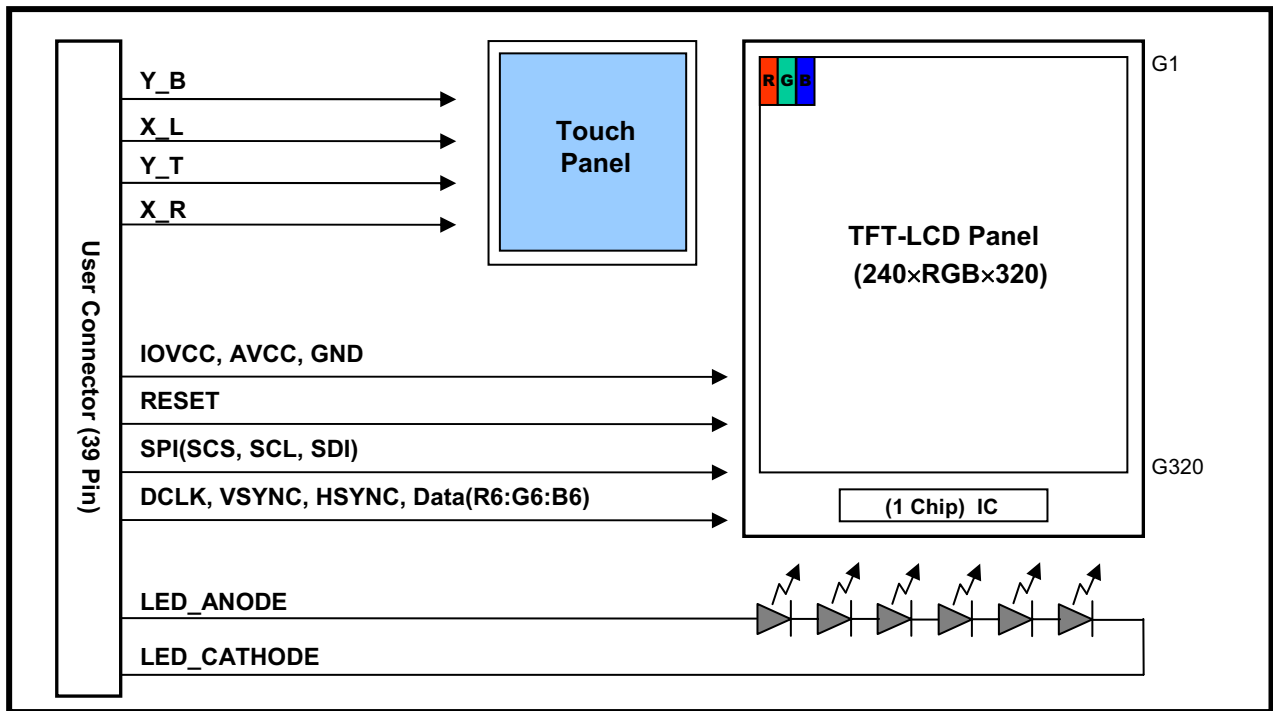

General Features

Item	Unit	Description	Remarks
Active screen size	Inch	3.5	Diagonal
Display Type	-	Transmissive	Normally White
Outline Dimension	mm	60.7(H) x 84.0(V) x 3.3(T) (typ.)	w/o FPC
Pixel Pitch	mm	0.219(H) x 0.219(V)	
Pixel format	-	240 x RGB x 320	RGB Vertical Stripe
Number of Color	-	262,144	
Interface	-	SPI + 18bit RGB	
Power Consumption	mW	TBD(typ.)	LCD Panel + B/L
Brightness	cd/m ²	250(typ.)	with T/P @ 20mA (6 LEDs)
Viewing Direction	o'clock	7	Non-inversion Direction
Weight	g	TBD(typ.)	

2. ABSOLUTE MAXIMUM RATINGS

If used the beyond absolute maximum ratings, this device can permanently be damaged.

It is strongly recommended to use this device at a condition for normal operation.

Parameter	Symbol	Values		Unit	Remarks
		Min.	Max.		
Analog Power Supply Voltage	AVCC	-0.3	4.5	V	at 25 °C
IO Power Supply Voltage	IOVCC	-0.3	4.5	V	at 25 °C
LED Power Consumption	P_{LED}	-	120	mW	Note 1
LED Current	I_{LED}	-	30	mA	Note 1
Operating Temperature	Top	-20	70	°C	Note 2
Storage Temperature	Tst	-30	80	°C	Note 2
Storage Humidity	Hst	10	90	%RH	Note 2

Notes:

1. Applies to each LED individually. Please refer to the Fig. 2-1 for allowable forward current.
2. Wet bulb temperature should be 49 °C Max, and no condensation of water.

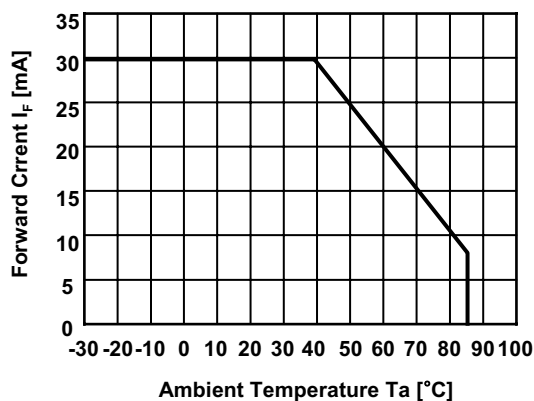

Fig. 2-1

3. ELECTRICAL SPECIFICATIONS

3-1. ELECTRICAL CHARACTERISTICS

(GND=0V, Ta=25 °C)

Parameter	Symbol	Values			Unit	Notes
		Min.	Typ.	Max.		
Analog Power Supply Voltage	AVCC	3.2	3.3	3.4	V	
I/O Power Supply Voltage	IOVCC	1.7	1.8	1.9	V	
"H"Level Input Voltage	V _{IH}	0.8IOVCC	-	IOVCC	V	Note 1
"L"Level Input Voltage	V _{IL}	-0.3	-	0.2IOVCC	V	Note 1
Power Consumption	P _{nor}		TBD		mW	Note 2
Power Consumption	P _{Stb}		TBD		uW	Note 2

Notes:

1. Applicable to Data(R6G6B6), DCLK, HSYNC, VSYNC, RESET, SCL, SDI, SCS signals
2. The specified current and power consumption are under the conditions at AVCC = 3.3V, IOVCC=1.8V and fv=TBD Hz, Black pattern is displayed and fv is the frame frequency.

3-2. BACKLIGHT UNIT

The edge-lighting type of back light unit consists of 6 LEDs which are connected in serial.

(GND=0V, Ta=25 °C)

Parameter	Symbol	Values			Unit	Notes
		Min.	Typ.	Max.		
LED Current	I _{LED}	-	20	30	mA	
LED Forward Voltage	V _{LED}	-	19.8		V	

3-3. TOUCH PANEL

(GND=0V, Ta=25 °C)

Parameter	Min.	Typ.	Max.	Unit	Remarks
Linearity	-1.5	-	1.5	%	
Terminal Resistance	100	-	1100	Ω	X-axis
	100	-	1100	Ω	Y-axis
Insulation Resistance	20	-	-	MΩ	DC 25V
Voltage	-	-	7	V	DC
Chattering	-	-	20	ms	DC 5V, 100kΩ
Transparency	78	80	-	%	

3-4. PIN ASSIGNMENT

This LCD employs one interface connection for the operation of module and LED B/L. The pin configuration for the connector is shown in the table below.

[Mating connector: FH23-39S-0.3SHW(HIROSE) or equivalent]

Pin No.	Symbol	I/O	Description
1	GND	Power	Ground Reference (0V)
2	IOVCC	Power	I/O Power Supply
3	AVCC	Power	Analog Power Supply
4	GND	Power	Ground Reference (0V)
5	B0	I	Blue Data
6	B1	I	Blue Data
7	B2	I	Blue Data
8	B3	I	Blue Data
9	B4	I	Blue Data
10	B5	I	Blue Data (MSB)
11	G0	I	Green Data
12	G1	I	Green Data
13	G2	I	Green Data
14	G3	I	Green Data
15	G4	I	Green Data
16	G5	I	Green Data (MSB)
17	R0	I	Red Data
18	R1	I	Red Data
19	R2	I	Red Data
20	R3	I	Red Data
21	R4	I	Red Data
22	R5	I	Red Data (MSB)
23	GND	Power	Ground Reference (0V)
24	VSYNC	I	Vertical Sync Signal
25	HSYNC	I	Horizontal Sync Signal
26	GND	Power	Ground Reference (0V)
27	DCLK	I	Dot Clock
28	GND	Power	Ground Reference (0V)
29	SDI	I	Serial Data Input
30	SCL	I	Serial Data Clock
31	SCS	I	Serial Chip Select
32	RESET	I	LCD Reset
33	GND	Power	Ground Reference (0V)
34	X_R	Analog	Touch Panel X-Right
35	Y_B	Analog	Touch Panel Y-Bottom
36	X_L	Analog	Touch Panel X-Left
37	Y_T	Analog	Touch Panel Y-Top
38	LED_C	I	LED Cathode
39	LED_A	I	LED Anode

3-5. COLOR INPUT DATA REFERENCE

Display Colors		Data Signal																	
		R 5	R 4	R 3	R 2	R 1	R 0	G 5	G 4	G 3	G 2	G 1	G 0	B 5	B 4	B 3	B 2	B 1	B 0
Basic Color	Black	0	0	0	0	0	0	0	0	0	0	0	0	0	0	0	0	0	0
	Red	1	1	1	1	1	1	0	0	0	0	0	0	0	0	0	0	0	0
	Green	0	0	0	0	0	0	1	1	1	1	1	1	0	0	0	0	0	0
	Blue	0	0	0	0	0	0	0	0	0	0	0	0	1	1	1	1	1	1
	Cyan	0	0	0	0	0	0	1	1	1	1	1	1	1	1	1	1	1	1
	Magenta	1	1	1	1	1	1	0	0	0	0	0	0	1	1	1	1	1	1
	Yellow	1	1	1	1	1	1	1	1	1	1	1	1	0	0	0	0	0	0
	White	1	1	1	1	1	1	1	1	1	1	1	1	1	1	1	1	1	1
Red Gray Scale	Black	0	0	0	0	0	0	0	0	0	0	0	0	0	0	0	0	0	0
	Darker ↑ ↓ Brighter	0	0	0	0	0	1	0	0	0	0	0	0	0	0	0	0	0	0
		0	0	0	0	1	0	0	0	0	0	0	0	0	0	0	0	0	0
		•	•	•	•	•	•	•	•	•	•	•	•	•	•	•	•	•	•
	1	1	1	1	0	1	0	0	0	0	0	0	0	0	0	0	0	0	
	1	1	1	1	1	0	0	0	0	0	0	0	0	0	0	0	0	0	
Red	1	1	1	1	1	1	0	0	0	0	0	0	0	0	0	0	0	0	
Green Gray Scale	Black	0	0	0	0	0	0	0	0	0	0	0	0	0	0	0	0	0	0
	Darker ↑ ↓ Brighter	0	0	0	0	0	0	0	0	0	0	0	1	0	0	0	0	0	0
		0	0	0	0	0	0	0	0	0	0	1	0	0	0	0	0	0	0
		•	•	•	•	•	•	•	•	•	•	•	•	•	•	•	•	•	•
	0	0	0	0	0	0	1	1	1	1	0	1	0	0	0	0	0	0	
	0	0	0	0	0	0	1	1	1	1	1	0	0	0	0	0	0	0	
Green	0	0	0	0	0	0	1	1	1	1	1	1	0	0	0	0	0	0	
Blue Gray Scale	Black	0	0	0	0	0	0	0	0	0	0	0	0	0	0	0	0	0	0
	Darker ↑ ↓ Brighter	0	0	0	0	0	0	0	0	0	0	0	0	0	0	0	0	0	1
		0	0	0	0	0	0	0	0	0	0	0	0	0	0	0	0	1	0
		•	•	•	•	•	•	•	•	•	•	•	•	•	•	•	•	•	•
	0	0	0	0	0	0	0	0	0	0	0	0	1	1	1	1	0	1	
	0	0	0	0	0	0	0	0	0	0	0	0	1	1	1	1	1	0	
Blue	0	0	0	0	0	0	0	0	0	0	0	0	1	1	1	1	1	1	

3-6. SIGNAL TIMING SPECIFICATIONS

3-6-1. RGB Interface

Horizontal Timing

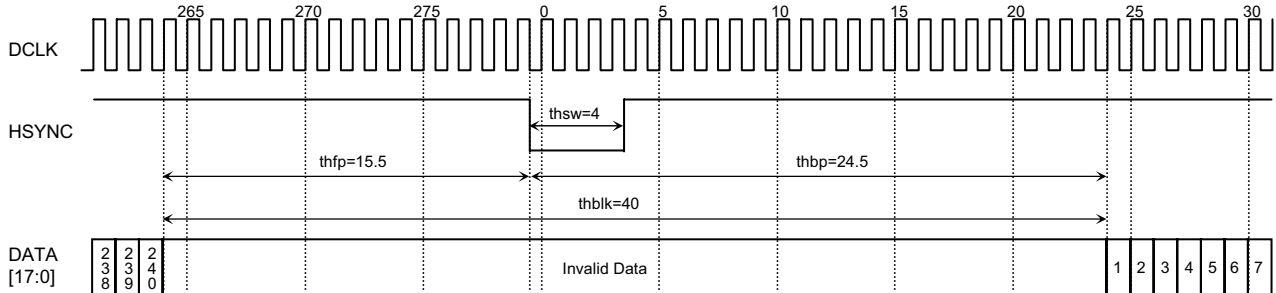

Vertical Timing

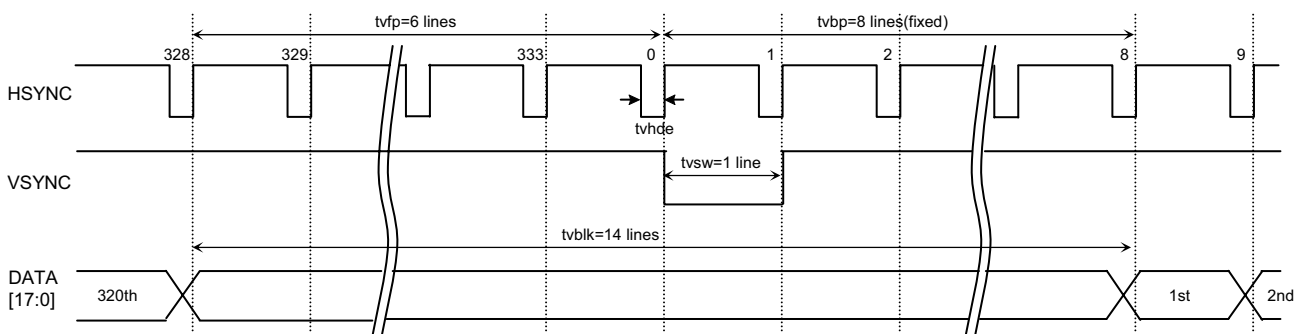

RGB Timing Parameters

Item	Symbol	Min.	Typ.	Max.	Unit	Remarks
Hsync low pulse width	thsw	5	4	8	clk	
Vsync low pulse width	thsw	1	1	4	line	
Number of Horizontal		272	280	288	clk	
Horizontal blanking period	thblk	32	40	48	clk	
Hsync falling edge -> 1 st data start	thbp	-	24.5	-	clk	
Hsync front porch	thfp	7.5	15.5	23.5	clk	
Number of vertical		332	334	336	line	
Vertical blanking period	tvblk	12	14	16	line	
Vsync falling edge -> 1 st data start	tvbp	-	8	-	line	
Vsync front porch	tvfp	4	6	8	line	
Vsync falling edge -> Hsync falling edge	tvhde	-5	-4	100	clk	

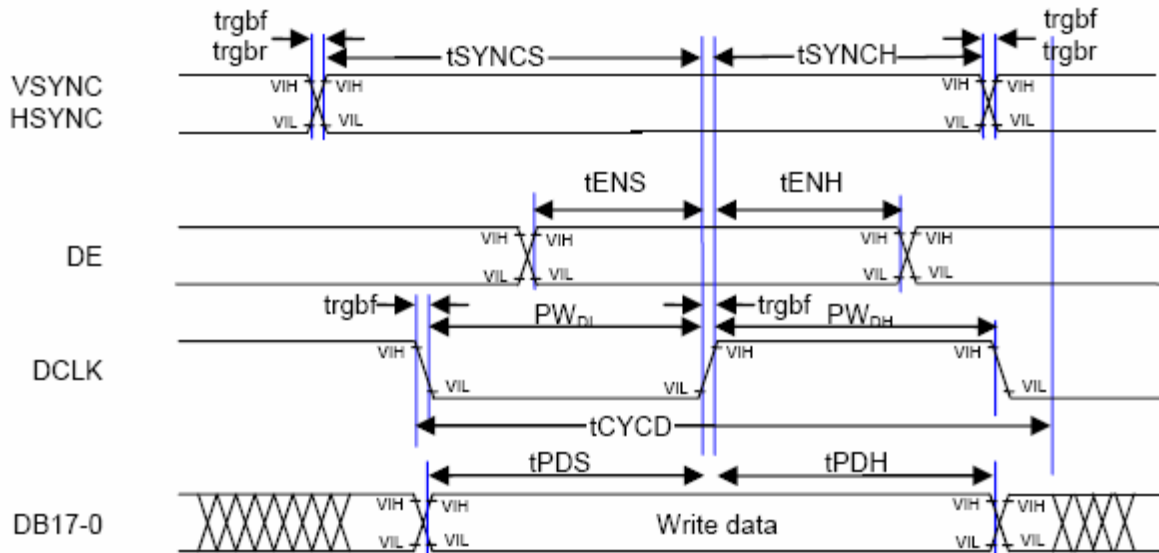
RGB Timing waveform

RGB Timing characteristics

Item	Symbol	Min.	Typ.	Max.	Unit	Remarks
Input clock voltage	V _{IL}	-0.3	-	0.2IOVCC	V	
	V _{IH}	0.8IOVCC	-	IOVCC	V	
Vertical frequency	f _v	-	54.5	-	Hz	
Horizontal frequency	f _h	-	18.2	-	kHz	
PCLK frequency	f _{tch}	-	5.1	-	MHz	
PCLK pulse width	t _{clk}	-	200	-	ns	
PCLK Low/High pulse width	PW _{DL} , PW _{DH}	32	0.5t _{clk}	-	ns	
PCLK cycle time	t _{CYCD}	80	-	-	ns	
Hsync setup time	t _{SYNCS}	20	-	-	ns	
Hsync hold time	t _{SYNCH}	20	-	-	ns	
Data setup time	t _{PDS}	20	-	-	ns	
Data hold time	t _{PDH}	20	-	-	ns	
Fast clock rise time	trgbr	-	-	25	ns	Note 1
Fast clock fall time	trgbf	-	-	25	ns	Note 1

Notes: 1. DCLK, HSYNC

3-6-2. Serial Peripheral Interface(SPI)

The Serial Peripheral Interface(SPI) is available via the chip select line(CS*), the serial transfer clock line(SCL), the serial data input(SDI), and the serial data output(SDO).

Data transfer in SPI mode

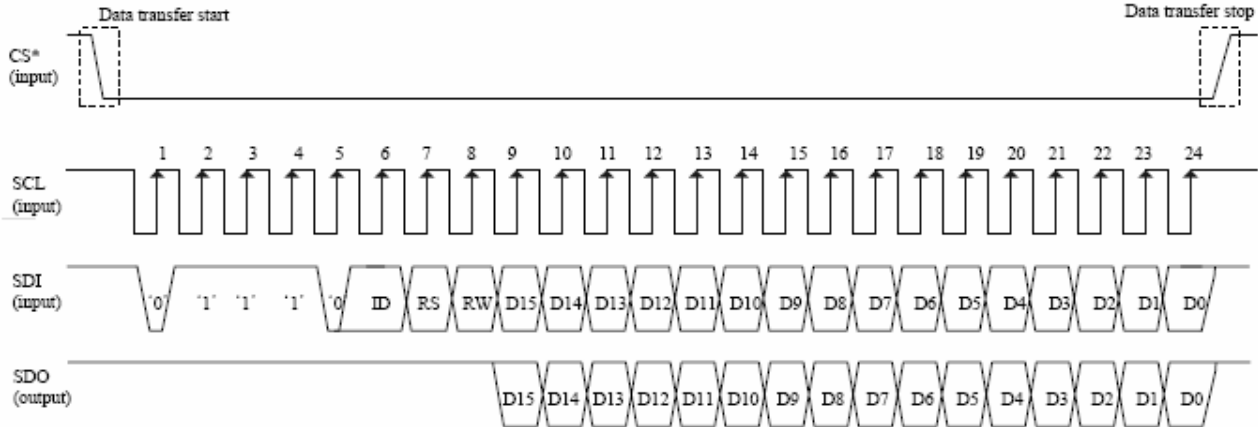

Register Selection

RS	R/W	Function
0	0	Set an index register
0	1	Read a status
1	0	Write an instruction
1	1	Read an instruction

Start byte format

Transferred bits	1	2	3	4	5	6	7	8
Start byte format	Device ID code						RS	R/W
	0	1	1	1	0	0		
						ID bit		

Note: ID bit is selected '0'

**Serial Peripheral Interface Timing Characteristics**

Item		Symbol	Unit	Min	Typ	Max
Serial clock cycle time	Write (received)	t_{SCYC}	ns	100	-	20000
	Read (transmitted)			350	-	20000
Serial clock "High" level pulse width	Write (received)	t_{SCH}	ns	40	-	-
	Read (transmitted)			150	-	-
Serial clock "Low" level pulse width	Write (received)	t_{SCL}	ns	40	-	-
	Read (transmitted)			150	-	-
Serial clock rise/fall time		t_{ser}, t_{scf}	ns	-	-	20
Chip select setup time		t_{CSU}	ns	20	-	-
Chip select hold time		t_{CH}	ns	60	-	-
Serial input data setup time		t_{SISU}	ns	30	-	-
Serial input data hold time		t_{SIH}	ns	30	-	-
Serial output data setup time		t_{SOD}	ns	-	-	130
Serial output data hold time		t_{SOH}	ns	5	-	-



4. OPTICAL CHARACTERISTICS

4-1. Optical Characteristics – Backlight Off

Parameter	Symbol	Condition	Min.	Typ.	Max.	Unit	Remarks
Reflectivity	R	Optimal		3.3		%	Note 1 (Diffuse light)
White Chromaticity	Wx			TBD			Note 1 (Spot light)
	Wy			TBD			
Contrast ratio	CR	Optimal		TBD			Note 2
Viewing angle Range	θ UP	CR \geq 2		50		°(degree)	Note 3
	θ DOWN			50		°(degree)	Note 3
	θ LEFT			50		°(degree)	Note 3
	θ RIGHT			50		°(degree)	Note 3
Response time	Tr + Tf	$\theta = 0^\circ$ Ta = 25 °C		40		ms	Note 4

4-2. Optical Characteristics – Backlight On

Parameter	Symbol	Condition	Min.	Typ.	Max.	Unit	Remarks
Brightness	Y	$I_{LED}=20mA$	200	250		cd/m ²	Note 1 [PR880]
Contrast ratio	CR	Optimal	120	200		-	Note 2
Viewing angle range	θ UP	CR \geq 5		(45)		°(degree)	Note 3
	θ DOWN			(45)		°(degree)	Note 3
	θ LEFT			45		°(degree)	Note 3
	θ RIGHT			45		°(degree)	Note 3
Response time	Tf + Tr	$\theta = 0^\circ$ Ta = 25 °C		35	50	ms	Note 4
Brightness Uniformity	Y	$I_{LED}=20mA$	75			%	Note 5 [PR880]
White Chromaticity	Wx	$\theta = 0^\circ$ Ta = 25 °C	0.260	0.310	0.360		Note 1 [PR650]
	Wy		0.280	0.330	0.380		
Red Chromaticity	Rx			TBD			
	Ry			TBD			
Green Chromaticity	Gx			TBD			
	Gy			TBD			
Blue Chromaticity	Bx			TBD			
	By			TBD			
Color Gamut	NTSC			50		%	

[Note 1] Optical Test Equipment Setup

Optical characteristics are determined after the unit has been 'ON' and stable for approximately 10 minutes in a dark environment at 25°C. The values specified are at an approximate distance 50cm from the LCD surface. In case of backlight on, measured on the center area of the panel by PHOTO RESEARCH photometer PR-880 & PR650 or Equivalent. In case of backlight off, measured on the center area of the panel by DMS-803

Diffuse light

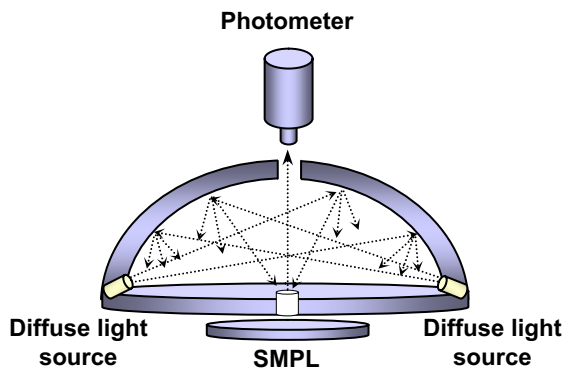

Spot light

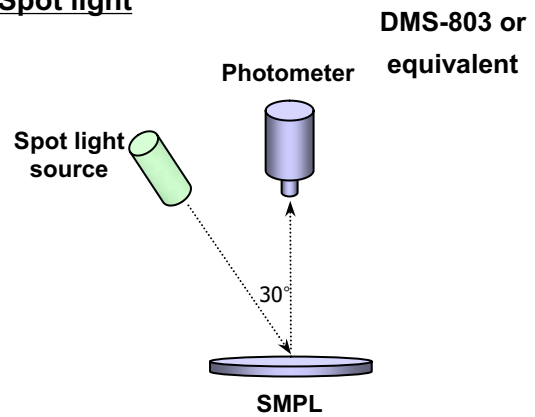

Fig 4.1 Backlight Off (Optical Characteristic Measurement Equipment and Method)

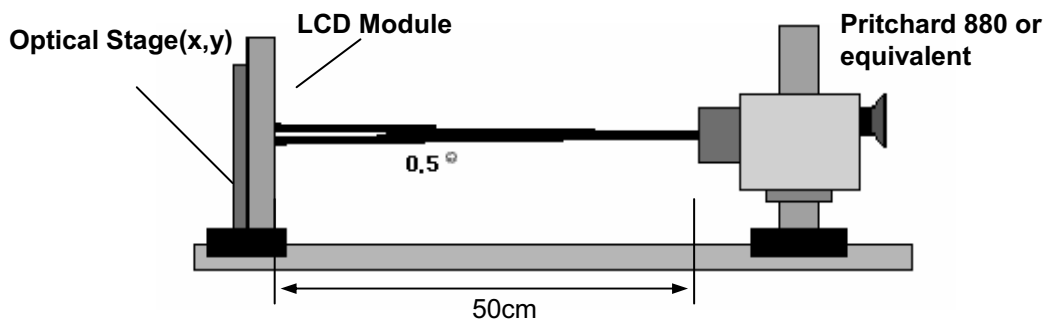

Fig 4.2 Backlight On (Optical Characteristic Measurement Equipment and Method)

[Note 2]

Contrast ratio is defined as follows ;

$$\text{Contrast Ratio(CR)} = \frac{\text{Photo detector output with LCD being "white"}}{\text{Photo detector output with LCD being "black"}}$$

[Note 3]

Viewing angle range is defined as follows;

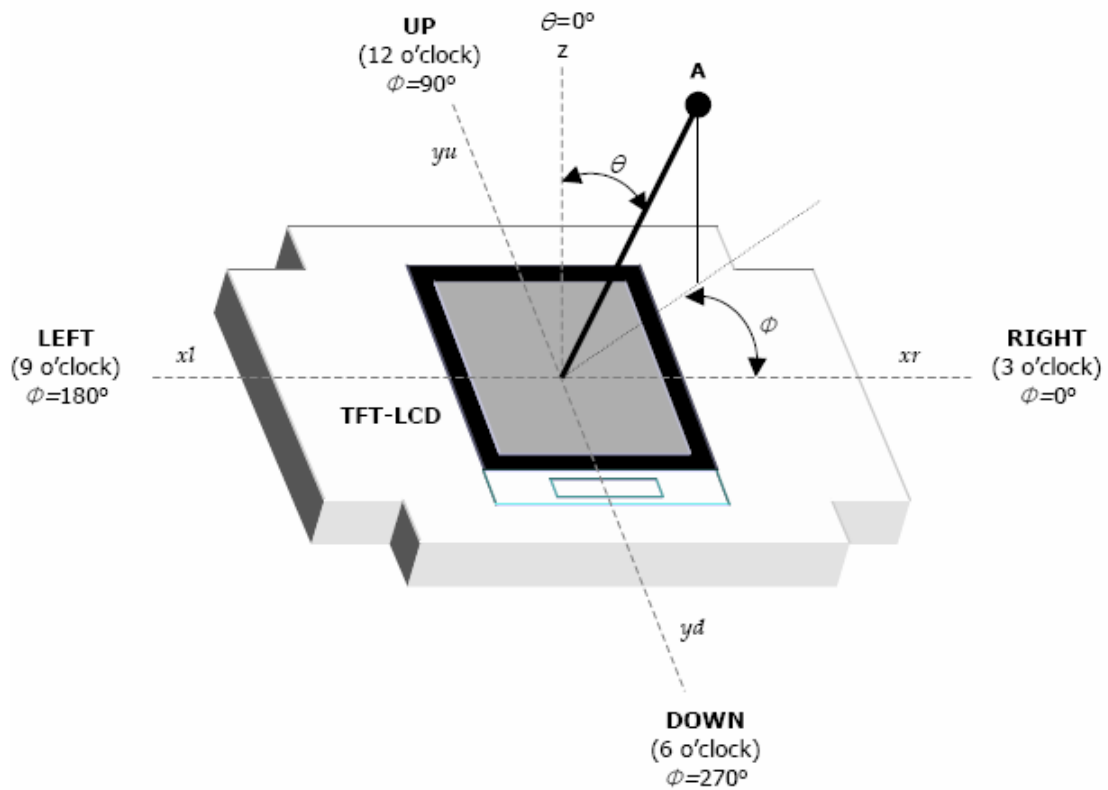

Fig 4.3 Viewing Angle

[Note 4]

Response time is obtained by measuring the transition time of photo detector output, when input signals are applied so as to make the area “black” to and from “white”.

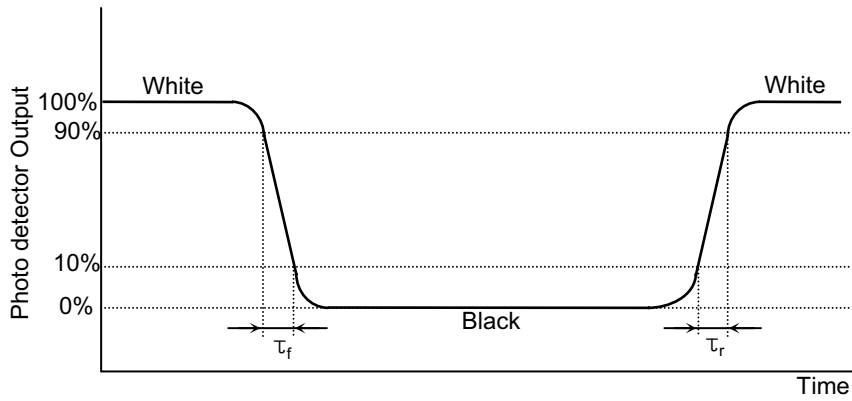

Fig 4.4 Response Time Definition

[Note 5]

The brightness measurement is taken at point B5.

$$\text{Brightness Uniformity} = \frac{\text{Minimum Photo detector output for B1-B9 with all pixels white}}{\text{Maximum Photo detector output for B1-B9 with all pixels white}} \times 100$$

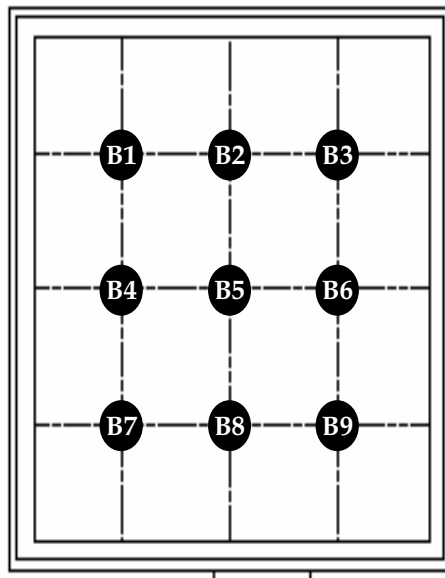

Fig 4.5 Brightness measurement points



5. MECHANICAL CHARACTERISTICS

The contents provide general mechanical characteristics for the model MI0350AT.

In addition the figures in the next page are detailed mechanical drawing of the LCD.

Dimension	Min.	Typ.	Max.	Unit
Horizontal (H)	60.5	60.7	60.9	mm
Vertical (V)	83.8	84.0	84.2	mm
Thickness (T)	3.1	3.3	3.5	mm

6. APPLICATION NOTE

Software flow chart

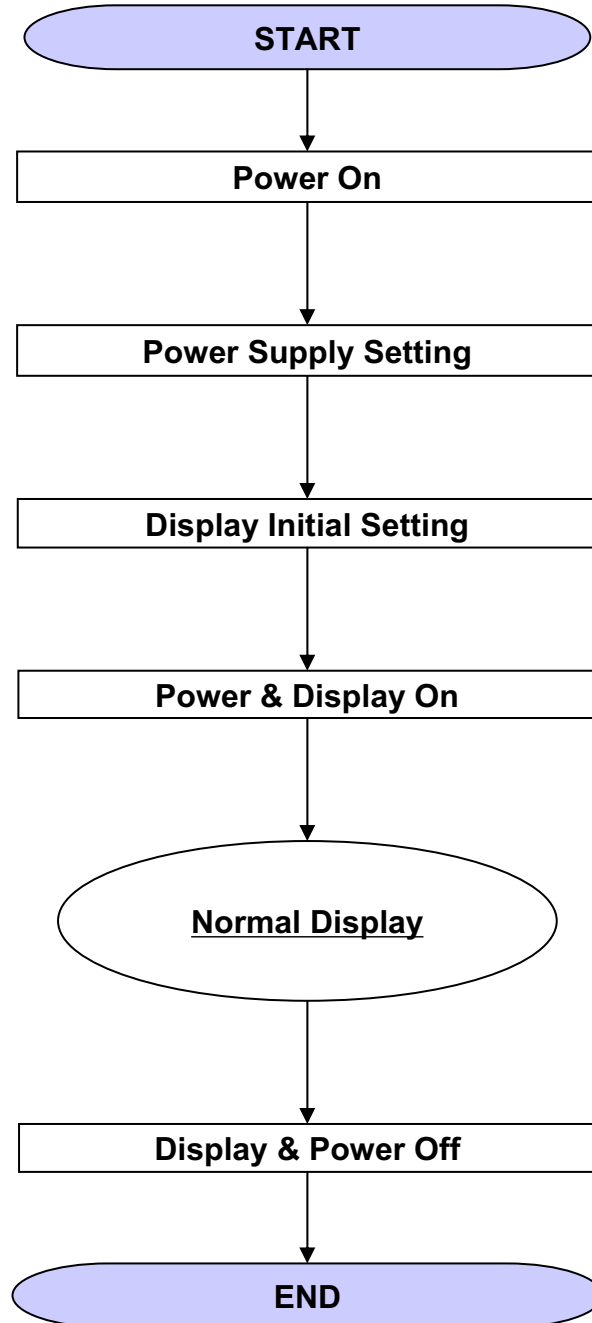

***Power On***

Step	Register Setting		Operation	Remarks
	Register	Data		
1	IOVCC, AVCC simultaneously			Power On
2	1ms Delay or more			
3	RESET 10ms			Note 1
4	10ms Delay or more			

Notes:

1. DCLK should be input prior to H/W RESET

Power Supply Setting

Step	Register Setting		Operation	Remarks
	Register	Data		
1	700004	720070	SPI Enable	
2	70000C	720237	VDD Regulator control	
3	700006	720020	Instruction before power supply(1)	
4	700008	72034A	Instruction before power supply(2)	
5	700009	720033	Instruction before power supply(3)	
6	70000A	72050A	Instruction before power supply(4)	
7	70000B	720852	Instruction before power supply(5)	
8	10ms Delay or more			

***Display Initial Setting***

Step	Register Setting		Operation	Remarks
	Register	Data		
1	700000	72726C	Resolution Control	
2	700001	7202A7	RGB Timing Control	
3	70000D	720000	Gamma Control(1)	
4	70000E	720707	Gamma Control(2)	
5	70000F	720402	Gamma Control(3)	
6	700010	720201	Gamma Control(4)	
7	700011	720000	Gamma Control(5)	
8	700012	720707	Gamma Control(6)	
9	700013	720402	Gamma Control(7)	
10	700014	720201	Gamma Control(8)	
11	700015	721C02	Gamma Control(9)	
12	700016	720202	Gamma Control(10)	
13	700017	720700	Gamma Control(11)	
14	700018	720104	Gamma Control(12)	
15	700019	720700	Gamma Control(13)	
16	70001A	720104	Gamma Control(14)	

Power & Display On

Step	Register Setting		Operation	Remarks
	Register	Data		
1	700006	720030	Power & Display On	Note 1
200ms Delay or more				

Notes:

1. Vsync should be input prior to Power & Display On.

Power & Display Off

Step	Register Setting		Operation	Remarks
	Register	Data		
1	700006	720020	Display & Power Off (1)	
60ms Delay or more				
2	700006	720120	Display & Power Off (2)	
20ms Delay or more				

7. RELIABILITY TEST

No.	Test Items	Test Condition	Remark
1	Low Temperature Storage	Ta=-30℃ 120hrs	
2	High Temperature Storage	Ta=80℃ 120hrs	
3	Low Temperature Operation	Ta=-20℃ 120hrs	
4	High Temperature Operation	Ta=70℃ 120hrs	
5	High Temperature and High Humidity Operation	Ta=50℃ 80%RH 120hrs	
6	Thermal Shock	-30C to +80C, 10 cycles, 30/30min (5 minute transfer time)	
7	Shock Test	Half sine wave, 180G, 2ms, 1 times shock of X, Y, Z axis	
8	Vibration Test	- X, Y, Z : 1hr(axis, sweep) - Acceleration : 10mm/4.4G/2.5G the amplitude is 10mm - Sweep range: 5~15Hz/10mm P-P/ 16~30Hz/4.4G, 30~300Hz/2.5G	
9	ESD	FPC Input Terminal: 0.2kV	(150pF, 330Ω) Non-operating

{ Result Evaluation Criteria }

TFT-LCD Panel should be at room temperature for 2 hours after the Reliability test is over.

There should be no particular change which might affect the practical display function and the display quality should be conducted under normal operating condition.

8. PACKING

- a) Package quantity in one box : 240 pcs
- b) Box Size : 475mm X 348mm X 210mm
- c) 1Box = 20(Full tray) + 1 (dummy / top tray) = 21 tray

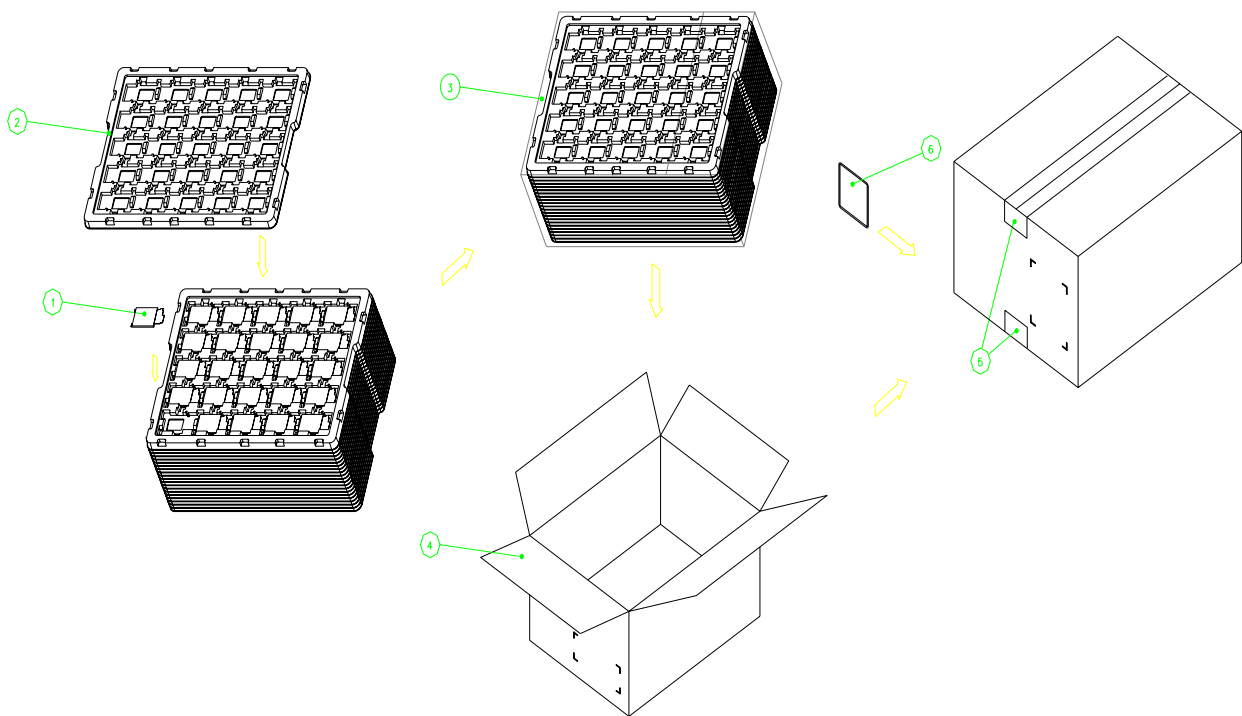

No.	Description	Material
1	Module	
2	Packing, tray	PET(0.8t)
3	Bag	PE 560x830
4	Box	SWR4
5	Tape	OPP 70MMx300m
6	Label	Art Paper 100x100

9. PRECAUTIONS

Please pay attention to the following when you use this TFT LCD module.

9-1. ASSEMBLY PRECAUTIONS

- (1) Please attach a transparent protective plate to the surface in order to protect the polarizer.
Transparent protective plate should have sufficient strength in order to resist external force.
- (2) You should adopt radiation structure to satisfy the temperature specification.
- (3) Acetic acid type and chlorine type materials for the cover case are not desirable because the former generates corrosive gas of attacking the polarizer at high temperature and the latter causes circuit break by electro-chemical reaction.
- (4) Do not touch, push or rub the exposed polarizers with glass, tweezers or anything harder than HB pencil lead. And please do not rub with dust clothes with chemical treatment.
Do not touch the surface of polarizer for bare hand or greasy cloth. (Some cosmetics deteriorate the polarizer.)
- (5) When the surface becomes dusty, please wipe gently with absorbent cotton or other soft materials like chamois soaks with petroleum benzine. Normal-hexane is recommended for cleaning the adhesives used to attach front / rear polarizers. Do not use acetone, toluene and alcohol because they cause chemical damage to the polarizer.
- (6) Wipe off saliva or water drops as soon as possible. Their long time contact with polarizer causes deformations and color fading.
- (7) Do not open the case because inside circuits do not have sufficient strength.
- (8) The metal case of a module should be contacted to electrical ground of your system.

9-2. OPERATING PRECAUTIONS

- (1) The spike noise causes the mis-operation of circuits. It should be lower than following voltage :
 $V = \pm 200\text{mV}$ (Over and under shoot voltage)
- (2) Response time depends on the temperature. (In lower temperature, it becomes longer.)
- (3) Brightness depends on the temperature. (In lower temperature, it becomes lower.)
And in lower temperature, response time (required time that brightness is stable after turned on) becomes longer.
- (4) Be careful for condensation at sudden temperature change. Condensation makes damage to polarizer or electrical contacted parts. And after fading condensation, smear or spot will occur.
- (5) When fixed patterns are displayed for a long time, remnant image is likely to occur.
- (6) Module has high frequency circuits. Sufficient suppression to the electromagnetic interference shall be done by system manufacturers. Grounding and shielding methods may be important to minimize the interference.

9-3. ELECTROSTATIC DISCHARGE CONTROL

Since a module is composed of electronic circuits, it is not strong to electrostatic discharge. Make certain that treatment persons are connected to ground through wrist band etc. And don't touch interface pin directly.

9-4. PRECAUTIONS FOR STRONG LIGHT EXPOSURE

Strong light exposure causes degradation of polarizer and color filter.

9-5. STORAGE

When storing modules as spares for a long time, the following precautions are necessary.

- (1) Store them in a dark place. Do not expose the module to sunlight or fluorescent light. Keep the temperature between 5°C and 35°C at normal humidity.
- (2) The polarizer surface should not come in contact with any other object.
It is recommended that they be stored in the container in which they were shipped.

9-6. HANDLING PRECAUTIONS FOR PROTECTION FILM

- (1) When the protection film is peeled off, static electricity is generated between the film and polarizer.
This should be peeled off slowly and carefully by people who are electrically grounded and with well ion-blown equipment or in such a condition, etc.
- (2) The protection film is attached to the polarizer with a small amount of glue. If some stress is applied to rub the protection film against the polarizer during the time you peel off the film, the glue is apt to remain on the polarizer.
Please carefully peel off the protection film without rubbing it against the polarizer.
- (3) When the module with protection film attached is stored for a long time, sometimes there remains a very small amount of glue still on the polarizer after the protection film is peeled off.
- (4) You can remove the glue easily. When the glue remains on the polarizer surface or its vestige is recognized, please wipe them off with absorbent cotton waste or other soft material like chamois soaked with normal-hexane.