



MULTI-INNO TECHNOLOGY CO., LTD.

LCD MODULE SPECIFICATION

Model : MI0177GT

Revision	1.0
Engineering	
Date	
Our Reference	



Table of Contents

Coversheet.....	1
Table of Contents	2
Record of Revision.....	3
1 General Specifications	4
2 Input/Output Terminals	5
3 Absolute Maximum Ratings	6
4 Electrical Characteristics.....	7
5 Timing Chart.....	9
6 Optical Characteristics	15
7 Environmental / Reliability Test	20
8 Mechanical Drawing.....	20
9 Packing Drawing	22
10 Precautions for Use of LCD Modules.....	23



1 General Specifications

	Feature	Spec
Display Spec	Size	1.77 inch
	Resolution	128(RGB) x160
	Interface	CPU 8 bit
	Color Depth	65K/262K
	Technology Type	a-Si
	Pixel Pitch (mm)	0.219 x 0.219
	Pixel Configuration	R.G.B. Vertical Stripe
	Display Mode	TM with Normally White
	Surface Treatment	Clear type (3H)
	Viewing Direction	6 o'clock
	Gray Scale Inversion Direction	12 o'clock
Mechanical Characteristics	LCM (W x H x D) (mm)	34.70x47.00x2.60
	Active Area(mm)	28.03x35.04
	With /Without TSP	Without TSP
	Weight (g)	TBD
	LED Numbers	1 LED
Electronic	Driver IC	HX8353D

Note 1: Viewing direction for best image quality is different from TFT definition, there is a 180 degree shift.

Note 2: Requirements on Environmental Protection: RoHS.

Note 3: LCM weight tolerance: +/- 5%.



2 Input/Output Terminals

2.1 TFT LCD Panel

No	Symbol	I/O	Description	Remark
1	GND	P	Ground	
2	NC(XR)	--	No connection	
3	NC(YU)	--	No connection	
4	NC(XL)	--	No connection	
5	NC(YD)	--	No connection	
6	GND	P	Ground	
7	VDD	P	Power supply	
8	/CS	I	Chip select signal , low: chip can be accessed	
9	RS	I	Command/Data select signal, low: instruction; high: data	
10	/WR	I	Write signal	
11	RD	I	Read signal	
12	D0	I	Data input	
13	D1	I	Data input	
14	D2	I	Data input	
15	D3	I	Data input	
16	D4	I	Data input	
17	D5	I	Data input	
18	D6	I	Data input	
19	D7	I	Data input	
20	/LCD_RESET	I	Reset signal	
21	GND	P	Ground	
22	NC	--	No connection	
23	LEDA	P	Back light anode	
24	NC	--	No connection	
25	LEDK	P	Back light cathode	

Note: I/O definition: I----Input; O---Output; P----Power/Ground.



3 Absolute Maximum Ratings

3.1 Driving TFT LCD Panel

GND=0V, Ta=25°C

Item	Symbol	Min	Max	Unit	Remark
Logic Supply Voltage	VDD	2.3	3.3	V	
Analog Supply Voltage	VDD	2.3	3.3	V	
Input Signal Voltage	CS,RS,/WR,RD /LCD_RESET,D[7:0]	-0.3	VDD+ 0.5	V	
Back Light Forward Current	I _{LED}	--	25.0	mA	For each LED
Operating Temperature	T _{OPR}	-20	70	°C	
Storage Temperature	T _{STG}	-30	80	°C	

4 Electrical Characteristics

4.1 Driving TFT LCD Panel

GND=0V, Ta=25°C

Item		Symbol	Min	Typ	Max	Unit	Remark
Logic Supply Voltage		VDD	2.3	2.8	3.3	V	
Analog Supply Voltage		VDD	2.3	2.8	3.3	V	
Input Signal Voltage	Low Level	V_{IL}	0	--	0.2xVDD	V	/CS,RS,/WR,RD /LCD_RESET,D[7:0]
	High Level	V_{IH}	0.8xVDD	--	VDD	V	
Output Signal Voltage	Low Level	V_{OL}	0	--	0.2xVDD	V	
	High Level	V_{OH}	0.8xVDD	--	VDD	V	
(Panel+ LSI) Power Consumption		Black Mode	--	TBD	--	mW	Frame Rate:60Hz
		Standby Mode	--	TBD	--	μ W	
		Sleeping Mode	--	TBD	--	μ W	

4.2 Driving Backlight

Ta=25°C

Item	Symbol	Min	Typ	Max	Unit	Remark
Forward Current	I_F	--	20	--	mA	For each LED
Forward Voltage	V_F	--	3.2	--	V	
Power Consumption	W_{BL}	--	64	--	mW	

Note 1: The figure below shows the connection of backlight LED.



Note 2: One LED: $I_F = 20\text{mA}$, $V_F = 3.2\text{V}$.

Note 3: The life of LED: 20,000 hrs.

4.3 Block Diagram

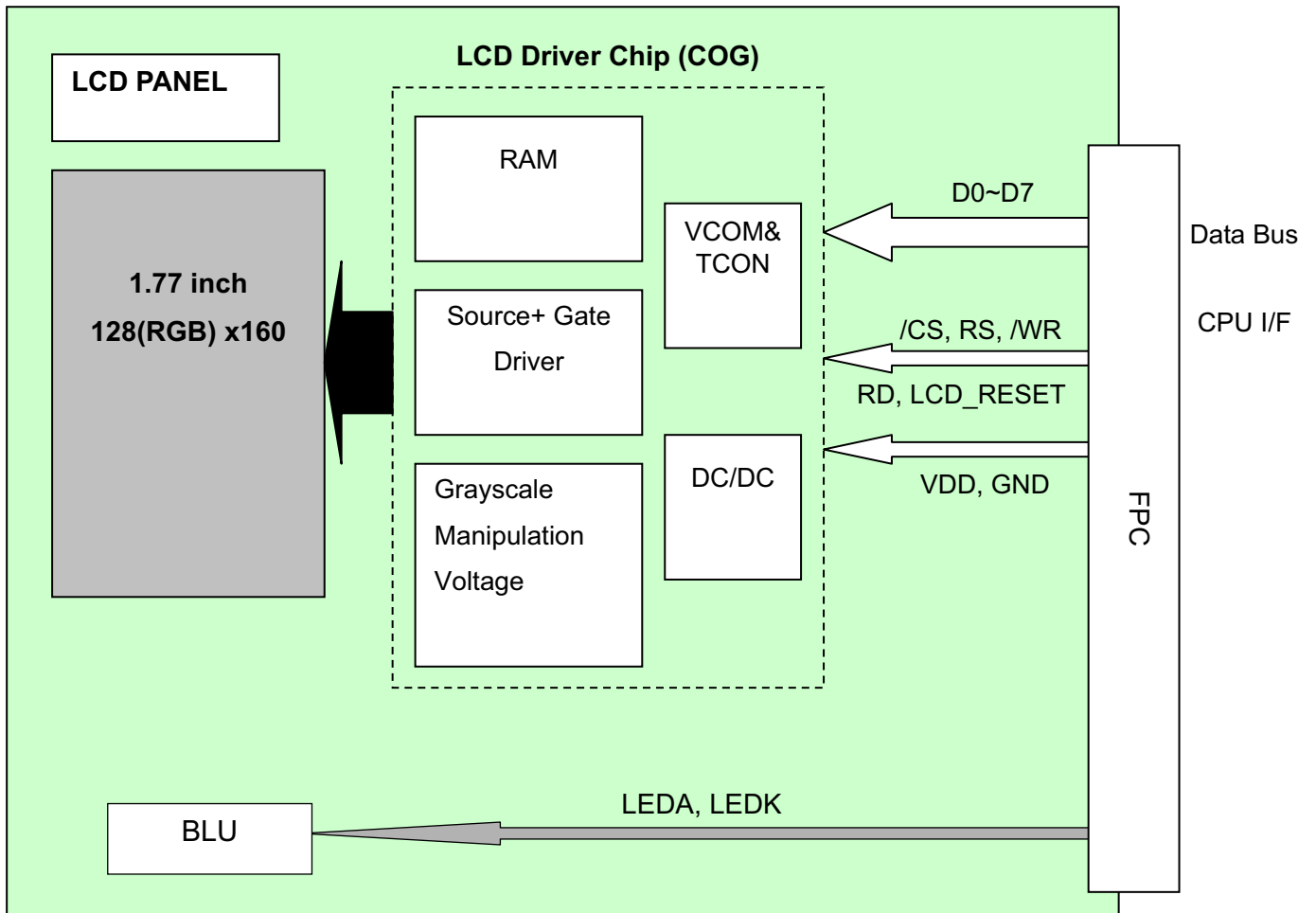

5.3 Register Write/Read timing

5.3.1 System Bus Interface Register Write Timing

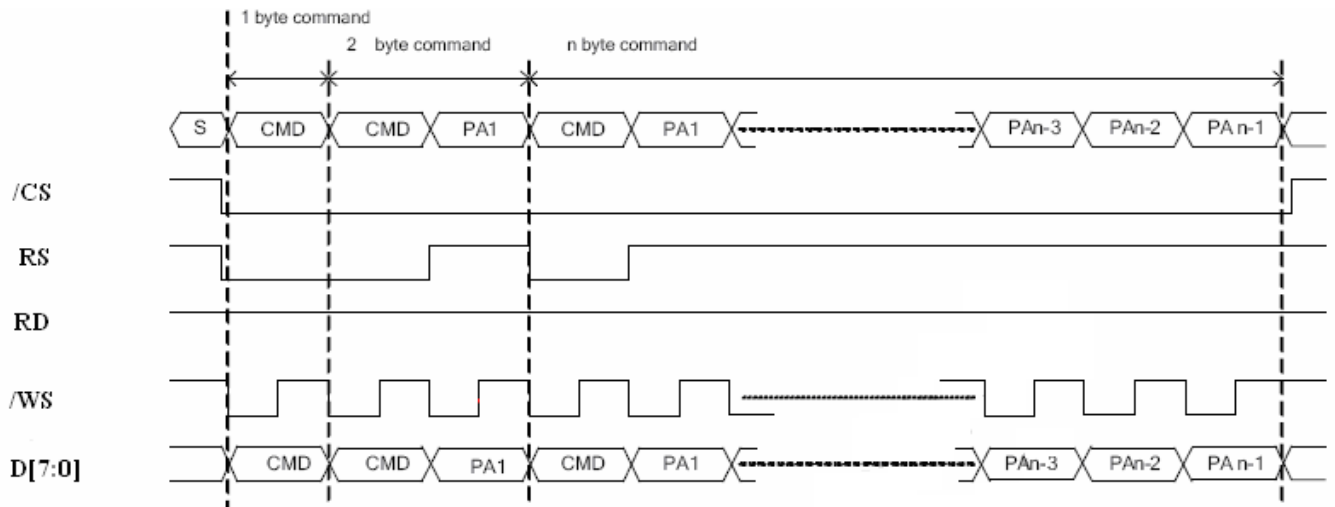

Note5-1: CMD: command code ; PA: parameter.

Figure 5.3.1 System Bus Interface Write Register Timing

5.3.2 System Bus Interface Register Read Timing

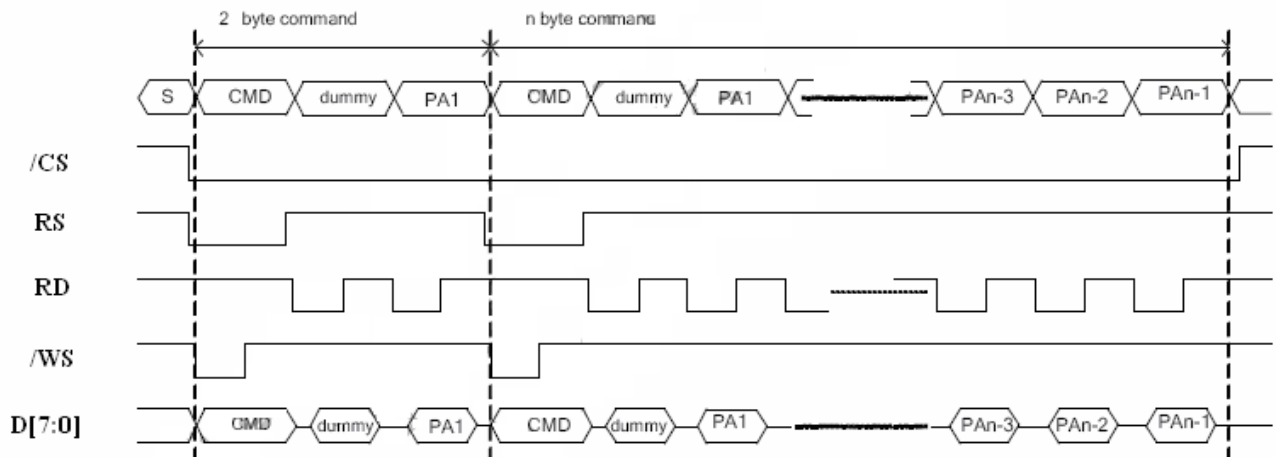
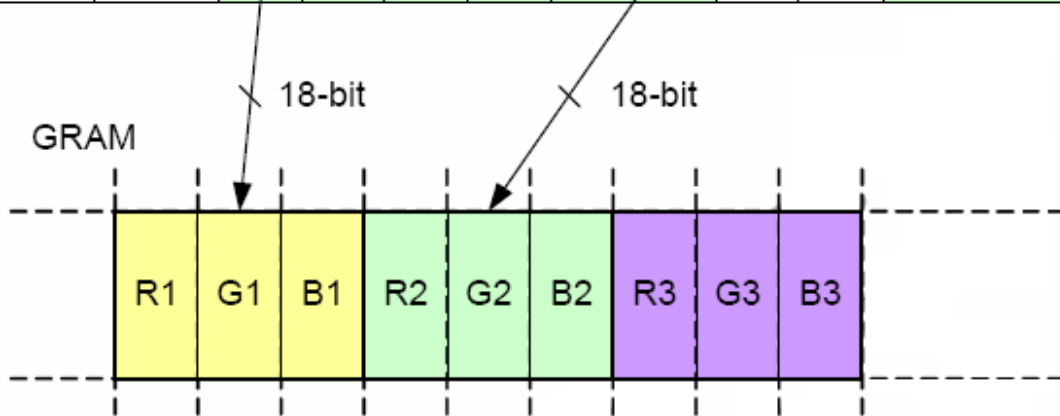

Figure 5.3.2 System Bus Interface Read Register Timing

5.4 GRAM Write/Read Data Format

262k Color Data	DNC/RS	DB7	DB6	DB5	DB4	DB3	DB2	DB1	DB0	GRAM Write
MEMWR	0	GRAM Write command code								-
1st write	1	R15	R14	R13	R12	R11	R10	x	x	-
2nd write	1	G15	G14	G13	G12	G11	G10	x	x	-
3rd write	1	B15	B14	B13	B12	B11	B10	x	x	1st pixel (R1/G1/B1)
4th write	1	R25	R24	R23	R22	R21	R20	x	x	-
5th write	1	G25	G24	G23	G22	G21	G20	x	x	-
6th write	1	B25	B24	B23	B22	B21	B20	x	x	2nd pixel (R2/G2/B2)

Figure 5.4.1 8-bit Data Bus GRAM Write/Read Data Format(262K)

65k Color Data	DNC/RS	DB7	DB6	DB5	DB4	DB3	DB2	DB1	DB0	GRAM Write
MEMWR	0	GRAM Write command code								-
1st write	1	R14	R13	R12	R11	R10	G15	G14	G13	-
2nd write	1	G12	G11	G10	B14	B13	B12	B11	B10	1st pixel (R1/G1/B1)
3rd write	1	R24	R23	R22	R21	R20	G25	G24	G23	-
4th write	1	G22	G21	G20	B24	B23	B22	B21	B20	2nd pixel (R2/G2/B2)

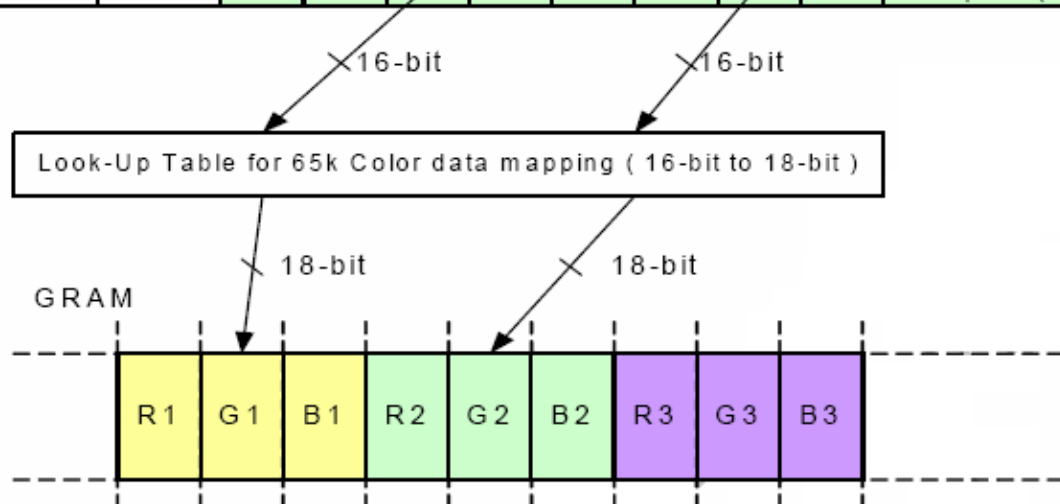
Figure 5.4.2 8-bit Data Bus GRAM Write/Read Data Format (65K)

5.5 GRAM Write/Read Timing

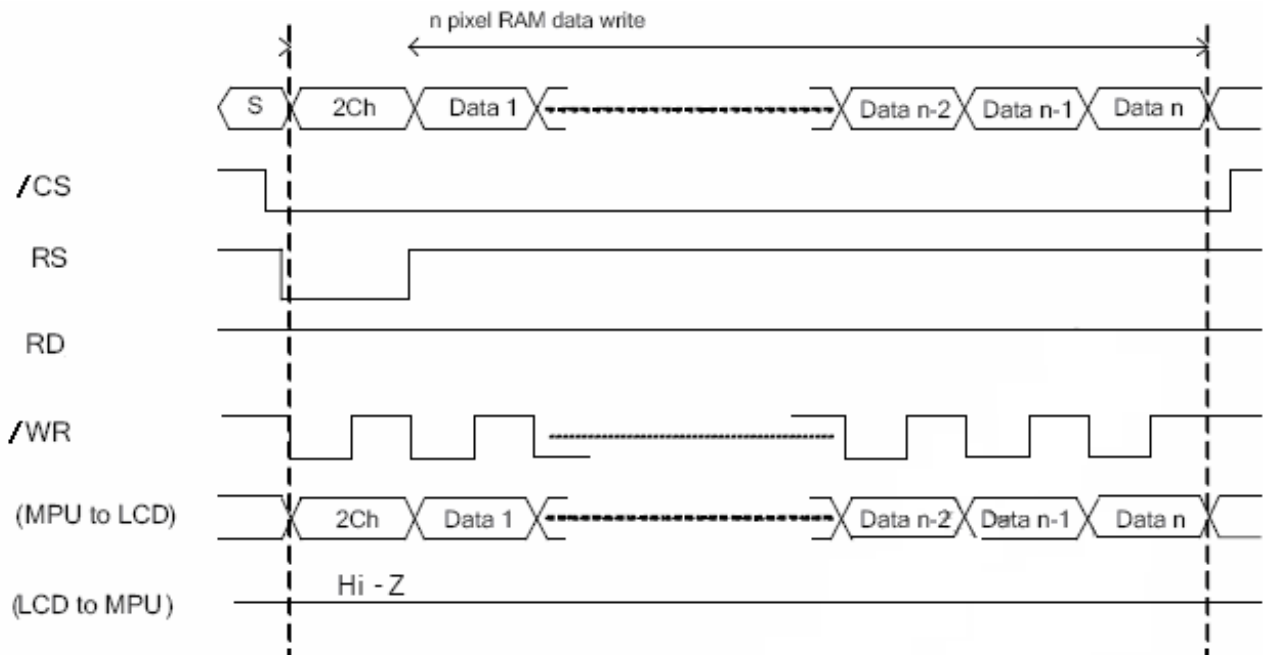

Figure 5.5.1 8-Bit Data Bus GRAM Write Timing

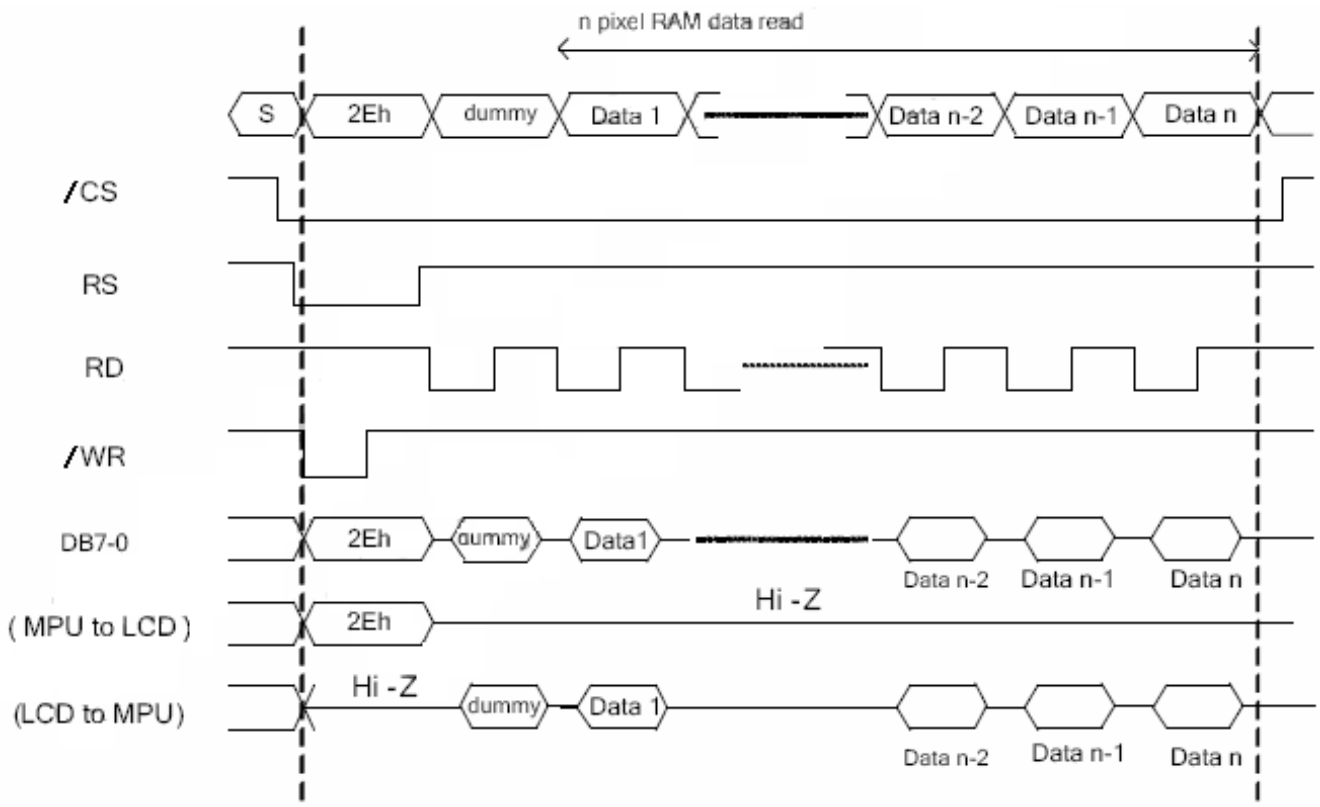

Figure 5.5.2 8-bit Data Bus GRAM Read Timing

5.6 Reset Timing Characteristics

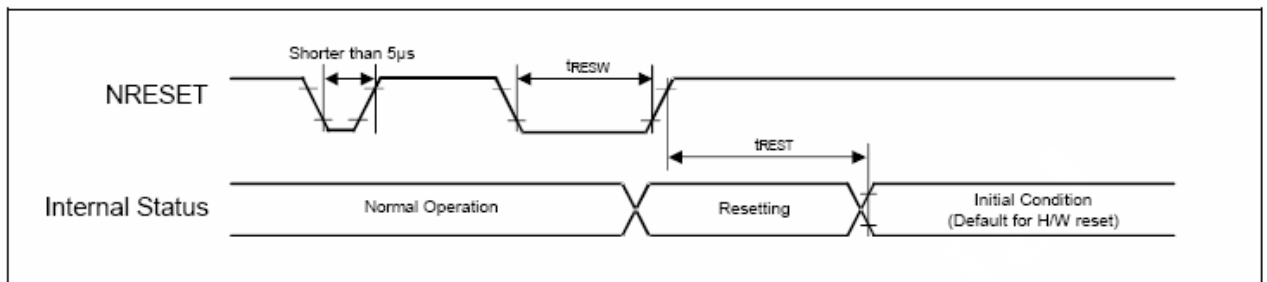

Figure 7. 6 Reset Input Timing

Symbol	Parameter	Related Pins	Spec.			Note	Unit
			Min.	Typ.	Max.		
t_{RESW}	Reset low pulse width ⁽¹⁾	NRESET	10	-	-	-	µs
t_{REST}	Reset complete time ⁽²⁾	-	-	-	5	When reset applied during Sleep In mode	ms
		-	-	-	120	When reset applied during Sleep Out mode	ms

Figure 5.6.1 Reset Timing

5.7 Power ON/OFF Sequence

5.7.1 Power ON Sequence

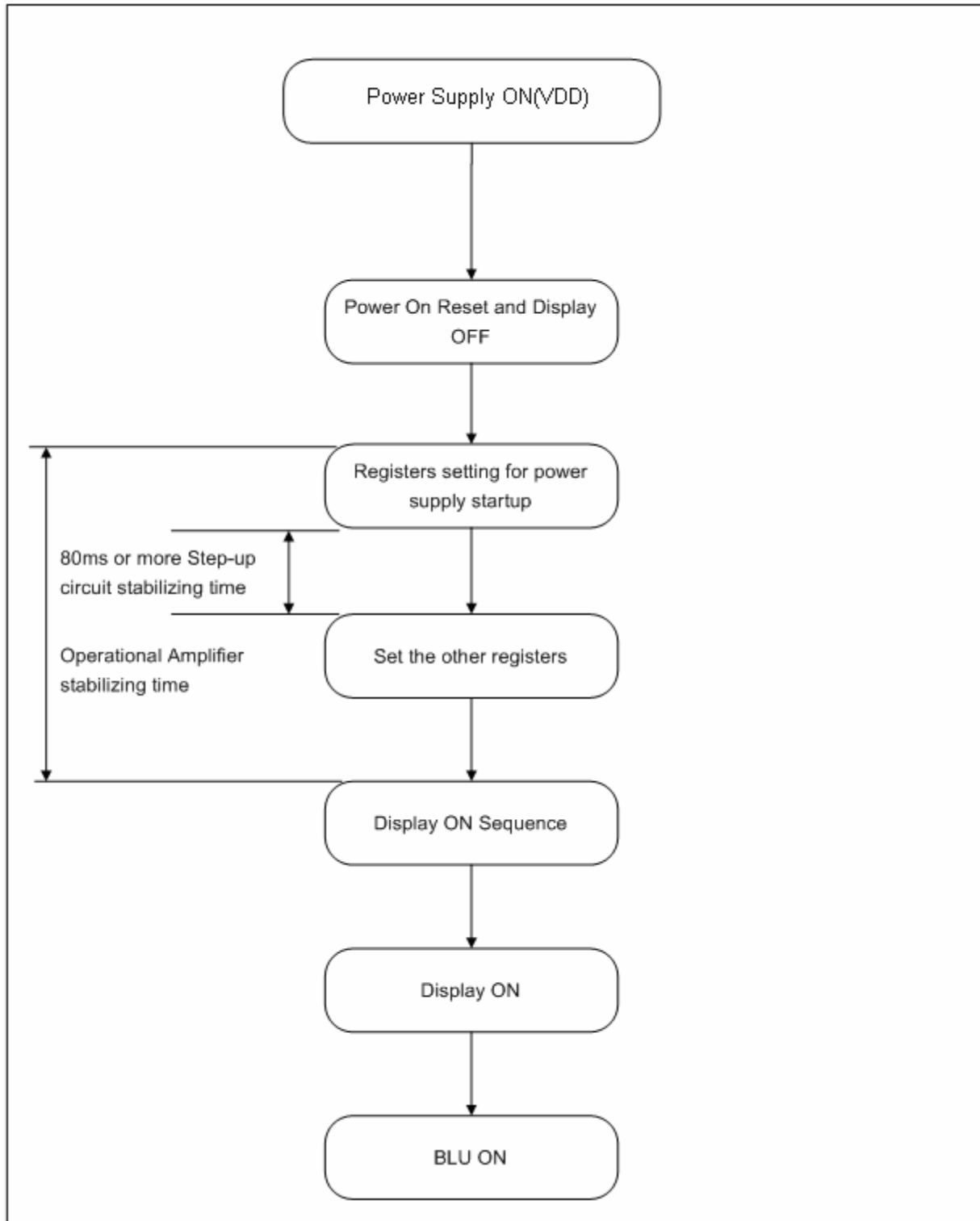

5.7.2 Power OFF Sequence

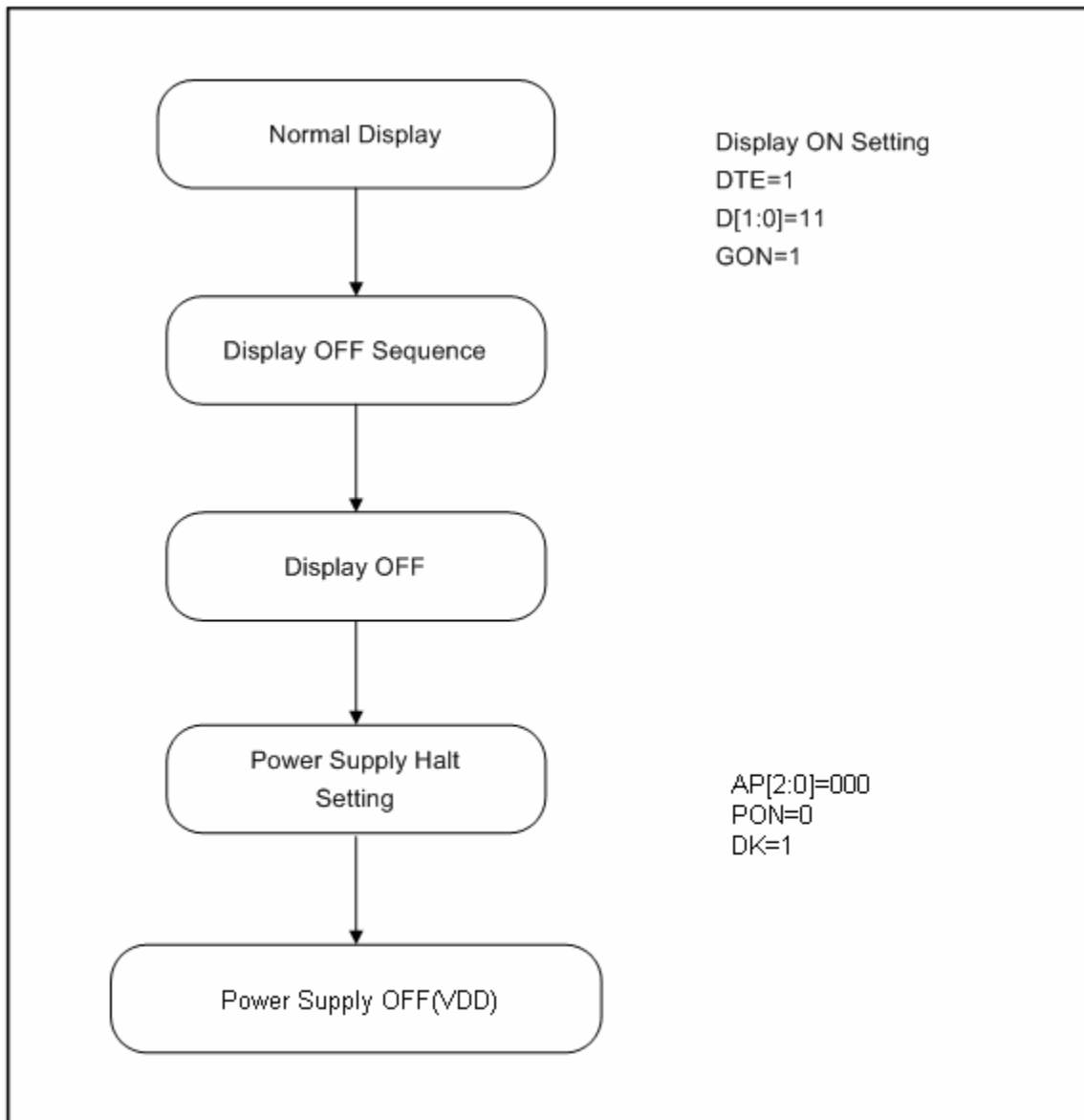

6 Optical Characteristics Optical Specification

Ta=25°C

Item	Symbol	Condition	Min	Typ	Max	Unit	Remark
View Angle	θT	CR \geq 10	60	70	--	Degree	Note 2
	θB		45	55	--		
	θL		60	70	--		
	θR		60	70	--		
Contrast Ratio	CR	$\theta=0^\circ$	350	400	--		Note1 Note3
Response Time	T _{ON}	25°C		30	--	ms	Note1 Note4
	T _{OFF}						
Chromaticity	White	Backlight is on	x	0.240	0.290	0.340	Note1 Note5
			y	0.270	0.320	0.370	
	Red		x	TBD	TBD	TBD	
			y	TBD	TBD	TBD	
	Green		x	TBD	TBD	TBD	
			y	TBD	TBD	TBD	
	Blue		x	TBD	TBD	TBD	
			y	TBD	TBD	TBD	
Uniformity (%)	U		80	--	--		Note1 Note6
NTSC (%)			--	40	--		Note5
Luminance	L		140	180	--		Note1 Note7

Test Conditions:

1. $V_F=3.2V$, $I_F=20mA$ (LED current), the ambient temperature is 25°C.
2. The test systems refer to Note1 and Note2.

Note 1: Definition of optical measurement system.

The optical characteristics should be measured in dark room. After 5 minutes operation, the optical properties are measured at the center point of the LCD screen. All input terminals LCD panel must be ground when measuring the center area of the panel.

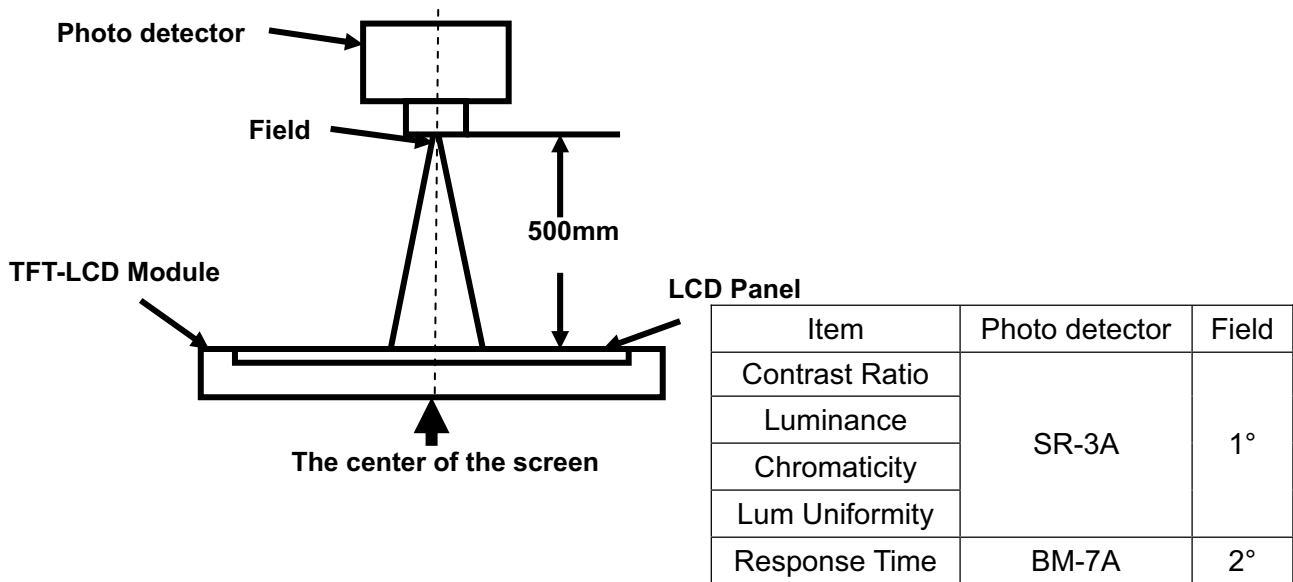
Note 2: Definition of viewing angle range and measurement system.

viewing angle is measured at the center point of the LCD by CONOSCOPE(ergo-80).

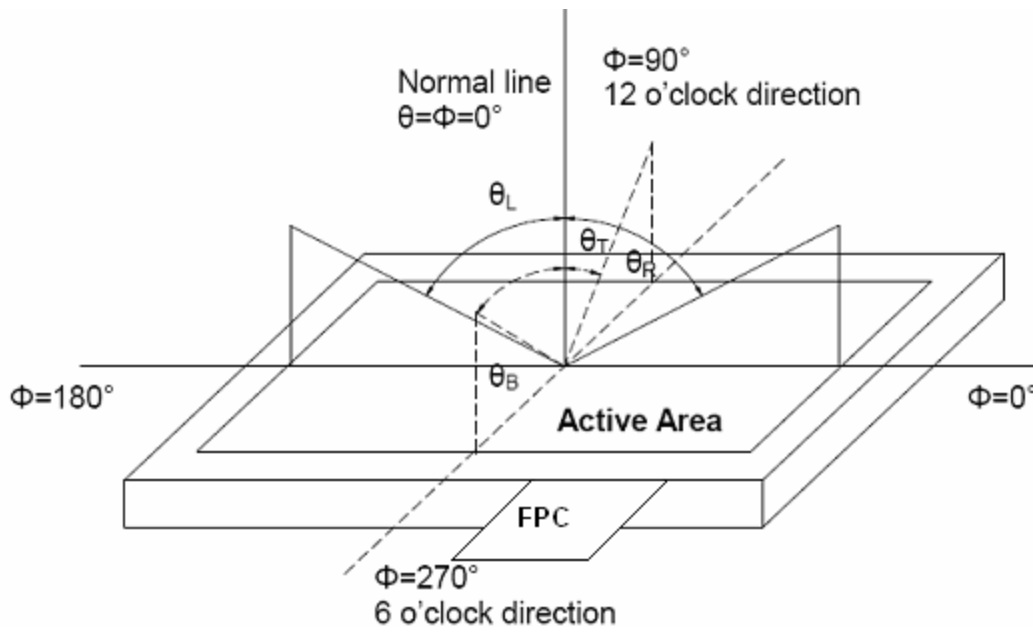

Fig. 1 Definition of viewing angle

Note 3: Definition of contrast ratio

$$\text{Contrast ratio (CR)} = \frac{\text{Luminance measured when LCD is on the "White" state}}{\text{Luminance measured when LCD is on the "Black" state}}$$

“White state “:The state is that the LCD should driven by V_{white} .

“Black state”: The state is that the LCD should driven by V_{black} .

V_{white} : To be determined V_{black} : To be determined.

Note 4: Definition of response time

The response time is defined as the LCD optical switching time interval between “White” state and “Black” state. Rise time (T_{ON}) is the time between photo detector output intensity changed from 90% to 10%. And fall time (T_{OFF}) is the time between photo detector output intensity changed from 10% to 90%.

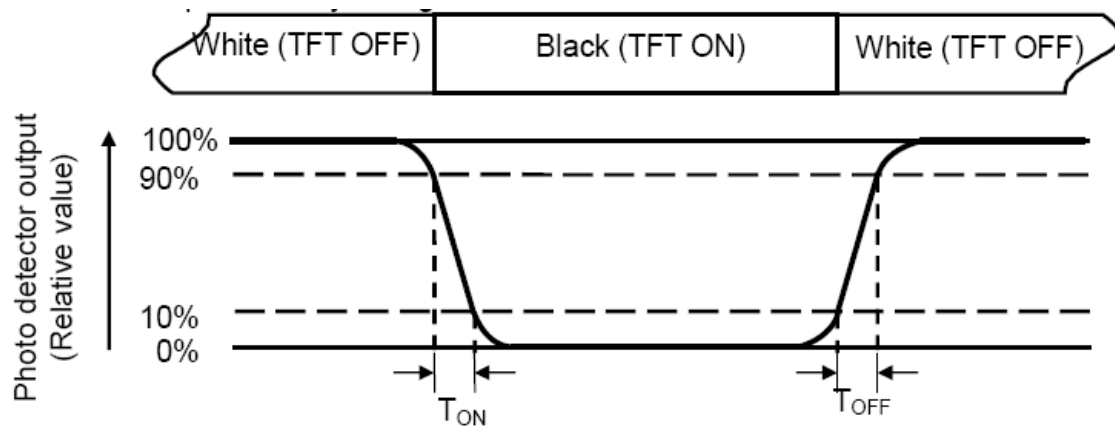
Note 5: Definition of color chromaticity (CIE1931)

Color coordinates measured at center point of LCD.

Note 6: Definition of luminance uniformity

Active area is divided into 9 measuring areas (Refer Fig. 2). Every measuring point is placed at the center of each measuring area.

$$\text{Luminance Uniformity}(U) = L_{\min} / L_{\max}$$

L-----Active area length W----- Active area width

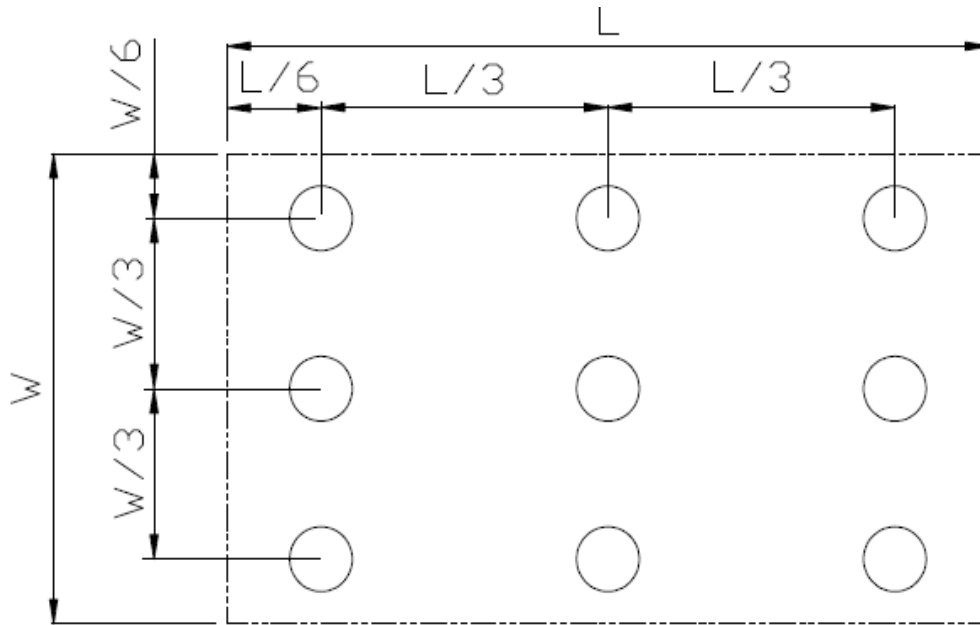

Fig. 2 Definition of uniformity

L_{\max} : The measured maximum luminance of all measurement position.

L_{\min} : The measured minimum luminance of all measurement position.

Note 7: Definition of luminance:

Measure the luminance of white state at center point.

7 Environmental / Reliability Test

No	Test Item	Condition	Remark
1	High Temperature Operation	Ts=+70°C, 240hrs	Note1 IEC60068-2-1,GB2423.2
2	Low Temperature Operation	Ta=-20°C, 240hrs	IEC60068-2-1 GB2423.1
3	High Temperature Storage	Ta=+80°C, 240hrs	IEC60068-2-1 GB2423.2
4	Low Temperature Storage	Ta=-30°C, 240hrs	IEC60068-2-1 GB2423.1
5	High Temperature & High Humidity Storage	Ta=+60°C, 90% RH 240 hours	Note2 IEC60068-2-78 GB/T2423.3
6	Thermal Shock (Non-operation)	-30°C 30 min~+80°C 30 min, Change time:5min, 20 Cycles	Start with cold temperature, End with high temperature, IEC60068-2-14,GB2423.22
7	Electro Static Discharge (Operation)	C=150pF, R=330Ω · 5points/panel Air:±8KV, 5times; Contact:±4KV, 5 times; (Environment: 15°C~35°C, 30%~60%, 86Kpa~106Kpa).	IEC61000-4-2 GB/T17626.2
8	Vibration (Non-operation)	Frequency range:10~55Hz, Stroke:1.5mm Sweep:10Hz~55Hz~10Hz 2 hours for each direction of X.Y.Z. (6 hours for total)(Package condition)	IEC60068-2-6 GB/T2423.10
9	Shock (Non-operation)	60G 6ms, ±X,±Y,±Z 3times, for each direction	IEC60068-2-27 GB/T2423.5
10	Package Drop Test	Height:80 cm,1 corner, 3 edges, 6 surfaces	IEC60068-2-32 GB/T2423.8
11	Package Vibration Test	Random Vibration: 0.015GxG/Hz for 5-200Hz, -6dB/Octave from 200-500Hz 2 hours for each direction of X,Y,Z (6 hours for total)	IEC60068-2-34 GB/T2423.11

Note1: Ts is the temperature of panel's surface.

Note2: Ta is the ambient temperature of sample.

8 Mechanical Drawing

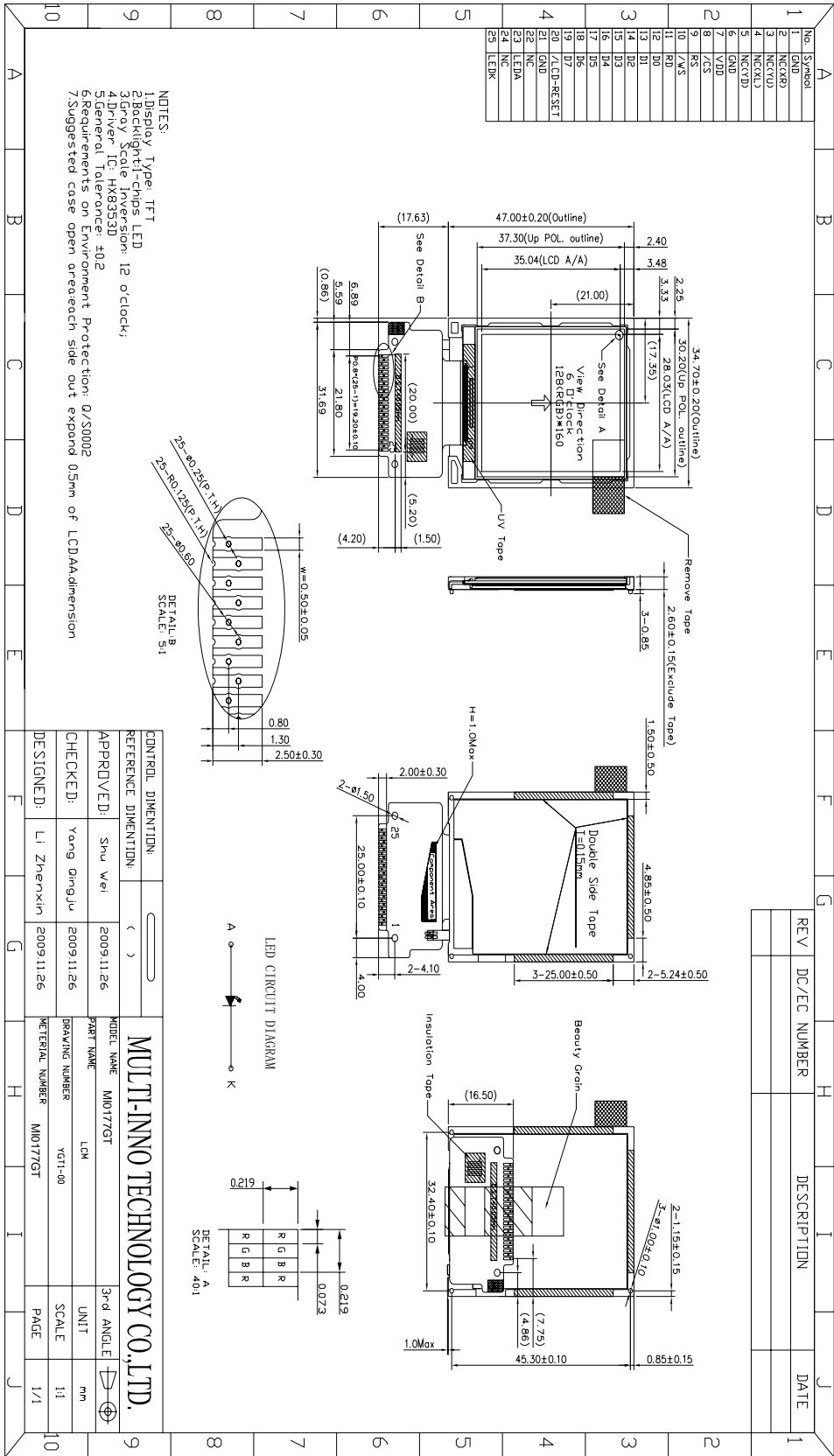



9 Packing Drawing

No	Item	Model (Material)	Dimensions(mm)	Unit Weight(Kg)	Quantity	Remark
1	LCM module	MI0177GT	TBD	TBD	TBD	
2	Tray	PET(Transmit)	TBD	TBD	TBD	
3	EPE	EPE	TBD	TBD	TBD	
4	Desiccant	Desiccant	TBD	TBD	TBD	
5	Anti-static bag	PE	TBD	TBD	TBD	
6	BOX	Corrugated paper	TBD	TBD	TBD	
7	Carton	Corrugated paper	TBD	TBD	TBD	
8	Total Weight(Kg)	TBD				

10 Precautions for Use of LCD Modules

10.1 Handling Precautions:

- 10.1.1 The display panel is made of glass. Do not subject it to a mechanical shock by dropping it from a high place, etc.
- 10.1.2 If the display panel is damaged and the liquid crystal substance inside it leaks out, be sure not to get any in your mouth, if the substance comes into contact with your skin or clothes, promptly wash it off using soap and water.
- 10.1.3 Do not apply excessive force to the display surface or the adjoining areas since this may cause the color tone to vary.
- 10.1.4 The polarizer covering the display surface of the LCD module is soft and easily scratched. Handle this polarizer carefully.
- 10.1.5 If the display surface is contaminated, breathe on the surface and gently wipe it with a soft dry cloth. If still not completely clear, moisten cloth with one of the following solvents:

- Isopropyl alcohol
- Ethyl alcohol

Solvents other than those mentioned above may damage the polarizer. Especially, do not use the following:

- Water
- Ketone
- Aromatic solvents

- 10.1.6 Do not attempt to disassemble the LCD Module.
- 10.1.7 If the logic circuit power is off, do not apply the input signals.
- 10.1.8 To prevent destruction of the elements by static electricity, be careful to maintain an optimum work environment.
 - 10.1.8.1 Be sure to ground the body when handling the LCD Modules.
 - 10.1.8.2 Tools required for assembly, such as soldering irons, must be properly ground.
 - 10.1.8.3 To reduce the amount of static electricity generated, do not conduct assembly and other work under dry conditions.
 - 10.1.8.4 The LCD Module is coated with a film to protect the display surface. Be care when peeling off this protective film since static electricity may be generated.

10.2 Storage precautions:

- 10.2.1 When storing the LCD modules, avoid exposure to direct sunlight or to the light of fluorescent lamps.
- 10.2.2 The LCD modules should be stored under the storage temperature range. If the LCD modules will be stored for a long time, the recommend condition is:
- 10.2.3 Temperature: 0°C~40°C Relatively humidity: ≤80%
- 10.2.4 The LCD modules should be stored in the room without acid, alkali and harmful gas.

10.3 Transportation Precautions:

The LCD modules should be no falling and violent shocking during transportation, and also should avoid excessive press, water, damp and sunshine.