

---

# PRODUCT SPECIFICATION

# VGY12864C

## 128x64 GRAPHICS OLED DISPLAY MODULE

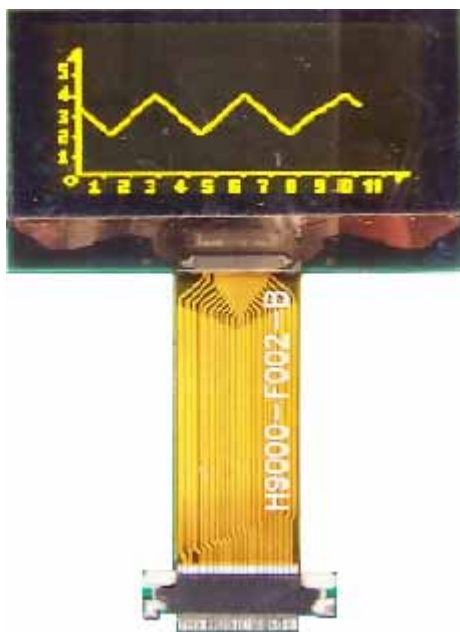

**VGY12864C-01 (3V) Yellow**

备注：我们针对多数电子系统的电压、结构、接口等需求，开发系列产品，满足您的设备要求。对于客户订制产品，我们承诺在 15 个工作日提交订制品，满足您的特殊需求。

---

**CONTENT**

1	Overview .....	3
2	Features .....	3
3	Mechanical Data .....	4
4	Recommended Operation Conditions .....	4
5	Electrical Characteristics.....	4
6	Module Drawing (VGY12864C-01).....	5
7	Function Block Diagram.....	6
8	Module Interface .....	6
9	Timing Characteristics .....	8
10	Display Control Instruction.....	11
11	Graphic Display Data Ram Address Map .....	13
12	Precautions for operation and Storage .....	14
	12.1 Precautions for Operation .....	14
	12.2 Soldering .....	14
	12.3 Precautions for Storage .....	14
	12.4 Warranty period.....	14
	12.5 Test Status .....	15

**History of Specification Revision**

Date	Rev.	Contents	Remark
2007.4	Initial	Release	Named

## 1 Overview

VGY12864C is an OLED monochrome 128x64 dot matrix display module. The characteristics of this display module are high brightness, self-emission, high contrast ratio, slim/thin outline, wide viewing angle, wide temperature range, and low power consumption.

The module displays data directly from its internal 128x64bits Graphic Display Data RAM(GDDRAM). Data/Commands are sent from general MCU through the hardware select able 6800-/8080-series compatible Parallel Interface or Serial Peripheral Interface.

## 2 Features

128x64 pixels

High contrast ratio

Wide viewing angle

Wide range of operating temperature

low power consumption

8-bit 8080-Databus or 8-bit 6800-series parallel interface or series peripheral interface

Display data is stored in Display Data RAM from MPU

Power supply to logic system: **+3V±10%**

Power supply to OLED driving system: **+10V to +14V**

Built-in SSD1305 standard OLED controller

**3 Mechanical Data**

NO.	ITEM	SPECIFICATION	UNIT
1	Dot Matrix	128(Columns) x 64(rows)	
2	Dot Size	0.244(W) x 0.244 (H)	mm
3	Dot Pitch	0.274 (W) x 0.274 (H)	mm
4	Grayscale	1 bit	
5	Active Area	35.04 (W) x 17.51 (H)	m <sup>2</sup>
6	Panel Size	45.24(W) x 29.14 (H) x2.2(T)	mm
7	Display Diagonal	1.5"	
8	Polarizer	with	
9	Duty	1/64	

**4 Recommended Operation Conditions**

Symbol	ITEM	MIN	TYP	MAX	UNIT
V <sub>DD</sub>	Logic supply voltage	2.4	3.0	3.5	V
V <sub>CC</sub>	Operating voltage	10	12	14	V
T <sub>op</sub>	Operating Temp.	-40	-	+80	
T <sub>stg</sub>	Storage Temp	-50	-	+85	

**5 Electrical Characteristics**

symbol	ITEM	Test condition	MIN	TYP	MAX	Unit
I <sub>CC</sub>	Operating supply Current	VDD=3.0	-	20	-	mA
I <sub>DD</sub>	Logic supply Current	VCC=12.0	-	-	-	mA
p <sub>T</sub>	Total Power	Note: 80cd/m <sup>2</sup> T <sub>op</sub> =25	-	150	300	mW
V <sub>IH</sub>	Digital Input HIGH	-	2.4	-	3.5	Volts
V <sub>IL</sub>	Digital Input LOW	-	0	-	0.2V <sub>DD</sub>	Volts
F <sub>FRM</sub>	Frame Frequency					Hz

Note: 80cd/m<sup>2</sup> with polarization film, be equal to 280cd/m<sup>2</sup>

6 Module Drawing (VGY12864C-01)

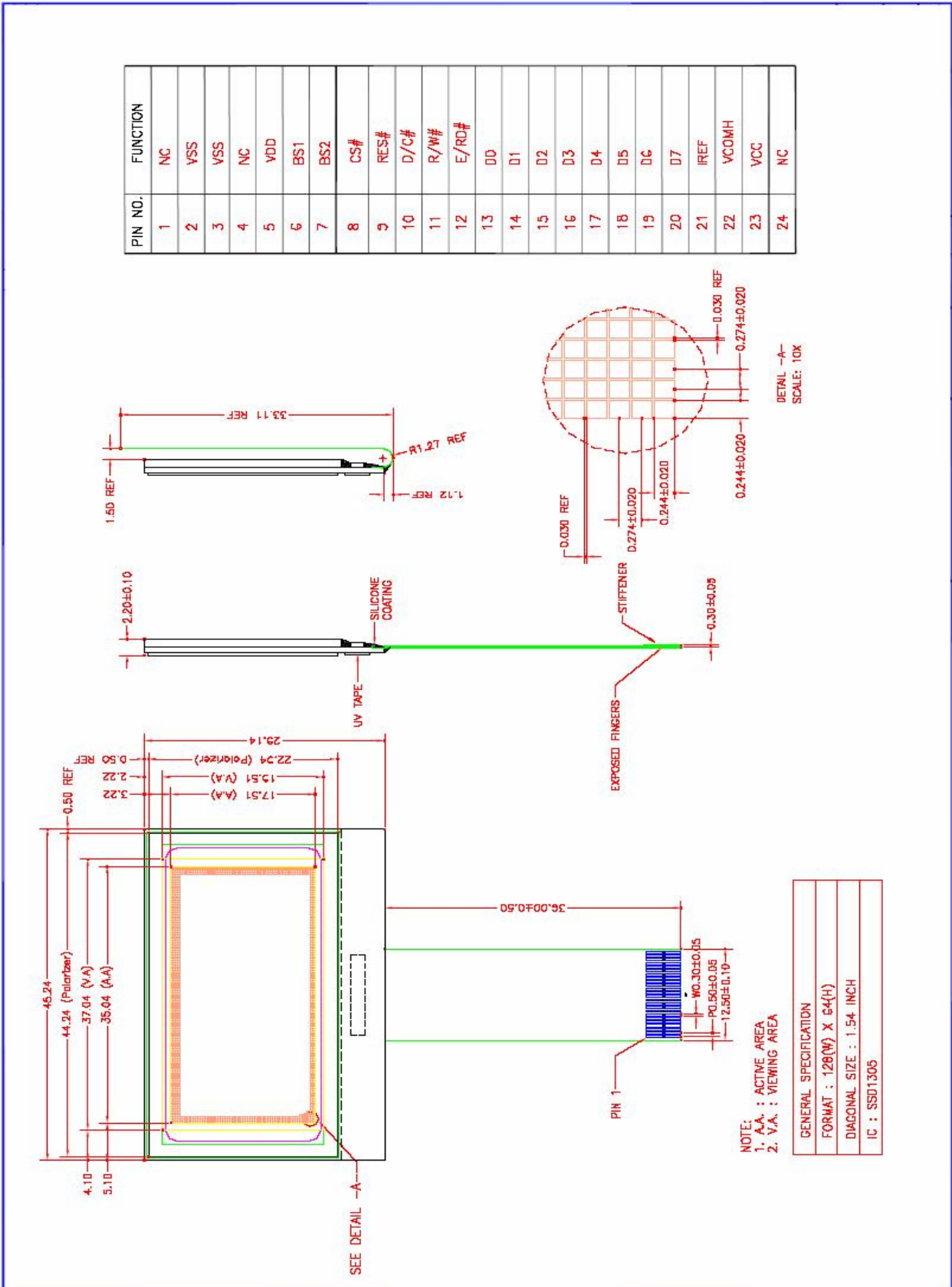

## 7 Function Block Diagram

128X64C OLED Module

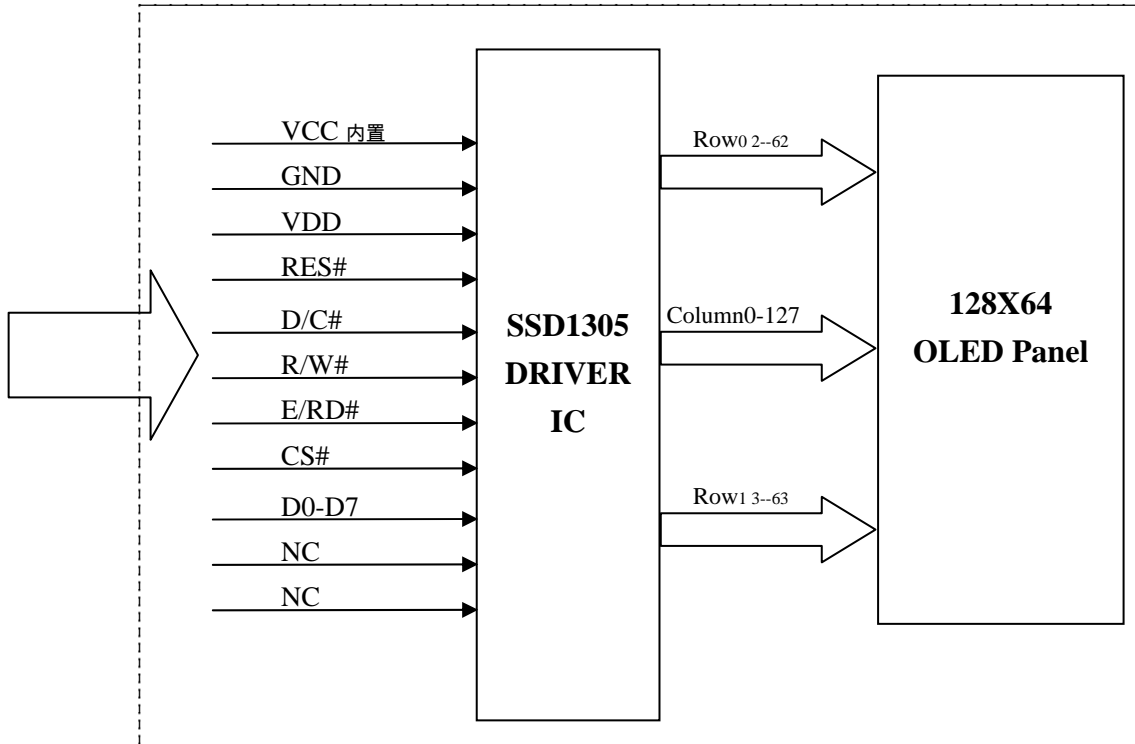

NOTE: Some pins omitted

## 8 Module Interface

VGY12864C-01

PIN NAME	PIN NO	DESCRIPTION			
NC	1	Not connect			
GND	2	Ground			
GND	3	Ground			
NC	4	Not connect			
VDD	5	Logic Voltage +3V			
BS1	6	These are MCU interface input selection pins. See the following table for selecting different interfaces:			
BS2	7	<b>Ttable</b>	6800-paralle interface	8080-parallel interface	Serial interface
		BS1	0	1	0
		BS2	1	1	0
CS#	8	Chip Select,active low			
RES#	9	Reset,active low			

D/C#	10	Data/Command Select. This is the Data/Command control pin. When it is pulled HIGH, the input at D7-D0 is treated as display data. When it is pulled LOW, the input at D7-D0 is transferred to the command registers. For detail relationship to MCU interface signals, please refer to the Timing Characteristics Diagrams.
R/W#	11	This is a MCU interface input pin. When 6800-series Parallel Interface mode is selected, this pin is used as Read/Write (R/W) selection input. Pull this pin to HIGH for read mode and pull it to LOW for write mode. When 8080-series Parallel Interface mode is selected, this pin is used as Write (WR#) selection input. Pull this pin to LOW for write mode. Data write operation is initiated when this pin is pulled LOW and the CS# is pulled LOW.
E(RD#)	12	This is a MCU interface input pin. When 6800-series Parallel Interface is selected, this pin is used as Enable (E) signal. Read/Write operation is initiated when this pin is pulled HIGH and the CS# pin is pulled LOW. When 8080-series Parallel Interface is selected, this pin is used to receive the Read Data (RD#)signal. Data read operation is initiated when this pin is pulled LOW and CS# pin is pulled LOW.
D0-D7	13-20	These are 8-bit bi-directional data bus to be connected to the microprocessor's data bus. When serial interface mode is selected, D1 will be the serial data input, SDIN, and D0 will be the serial clock input, SCLK.
IREF	21	Segment(Column) Current Reference. A resistor should be connected between this pin and VSS.
VCOMH	22	Common(Row) High Voltage, A Capacitor should be connect between this pin and VSS.
VCC	23	OLED drive voltage +12V (Don't care.)
NC	24	Not connect

## 9 Timing Characteristics

### VGY12864C-01

#### 6800-Series MPU Parallel Interface Timing Characteristics

(TA = 25°C)

Symbol	Parameter	Min	Typ	Max	Unit
$t_{cycle}$	Clock Cycle Time	300	-	-	ns
$t_{AS}$	Address Setup Time	0	-	-	ns
$t_{AH}$	Address Hold Time	0	-	-	ns
$t_{DSW}$	Write Data Setup Time	40	-	-	ns
$t_{DHW}$	Write Data Hold Time	15	-	-	ns
$t_{DHR}$	Read Data Hold Time	20	-	-	ns
$t_{OH}$	Output Disable Time	-	-	70	ns
$t_{ACC}$	Access Time	-	-	140	ns
$PW_{CSL}$	Chip Select Low Pulse Width (read) Chip Select Low Pulse Width (write)	120 60	-	-	ns
$PW_{CSH}$	Chip Select High Pulse Width (read) Chip Select High Pulse Width (write)	60 60	-	-	ns
$t_R$	Rise Time	-	-	15	ns
$t_F$	Fall Time	-	-	15	ns

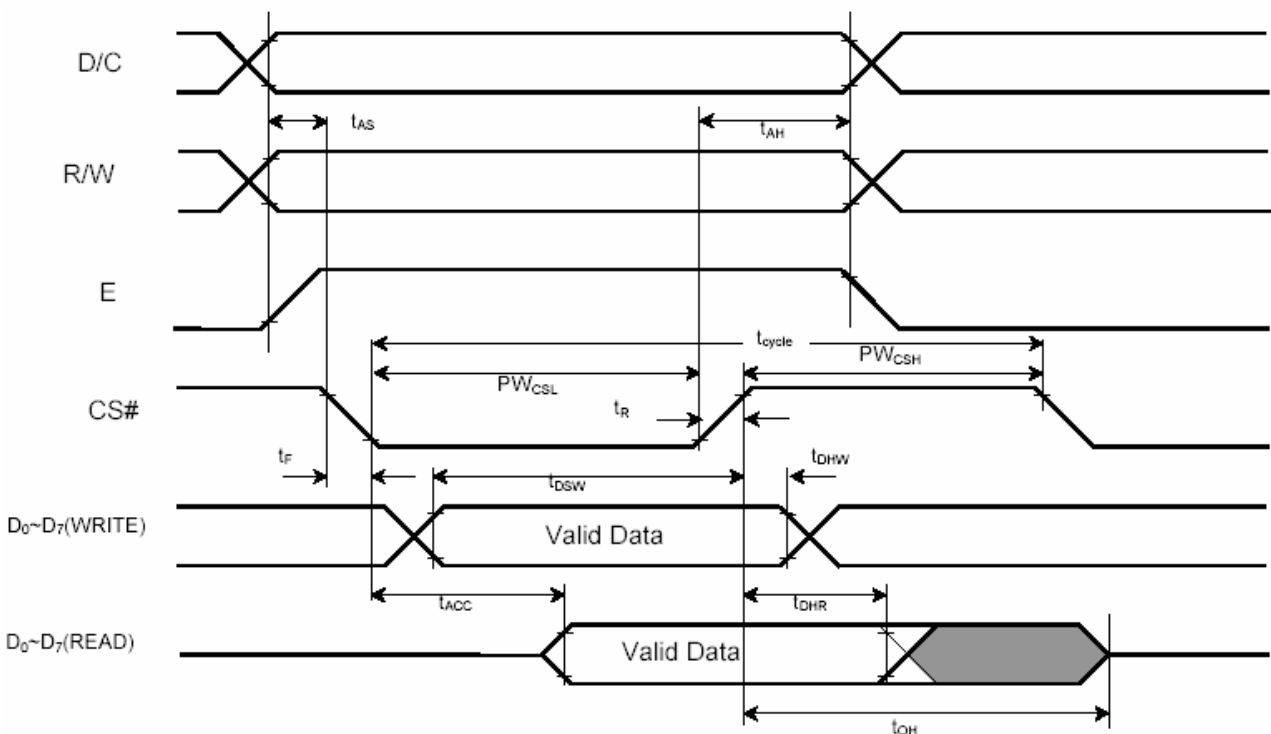

#### 6800-series MPU parallel interface characteristics

8080-Series MPU Parallel Interface Timing Characteristics

(TA =25°C)

Symbol	Parameter	Min	Typ	Max	Unit
$t_{cycle}$	Clock Cycle Time	300	-	-	ns
$t_{AS}$	Address Setup Time	0	-	-	ns
$t_{AH}$	Address Hold Time	0	-	-	ns
$t_{DSW}$	Write Data Setup Time	40	-	-	ns
$t_{DHW}$	Write Data Hold Time	15	-	-	ns
$t_{DHR}$	Read Data Hold Time	20	-	-	ns
$t_{OH}$	Output Disable Time	-	-	70	ns
$t_{ACC}$	Access Time	-	-	140	ns
$PW_{CSL}$	Chip Select Low Pulse Width (read)	120	-	-	ns
	Chip Select Low Pulse Width (write)	60	-	-	ns
$PW_{CSH}$	Chip Select High Pulse Width (read)	60	-	-	ns
	Chip Select High Pulse Width (write)	60	-	-	ns
$t_R$	Rise Time	-	-	15	ns
$t_F$	Fall Time	-	-	15	ns

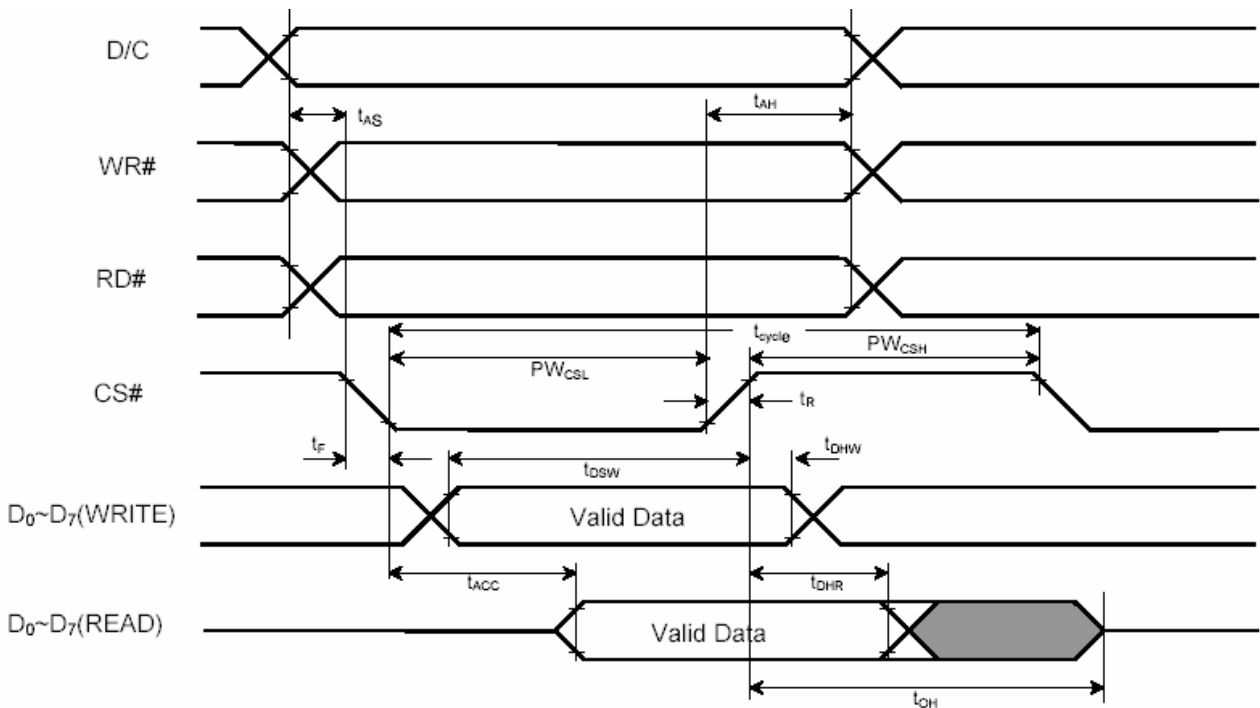

8080-series MPU parallel interface characteristics

Serial Interface Timing Characteristics

(TA = 25°C)

Symbol	Parameter	Min	Typ	Max	Unit
$t_{cycle}$	Clock Cycle Time	250	-	-	ns
$t_{AS}$	Address Setup Time	150	-	-	ns
$t_{AH}$	Address Hold Time	150	-	-	ns
$t_{CSS}$	Chip Select Setup Time	120	-	-	ns
$t_{CSH}$	Chip Select Hold Time	60	-	-	ns
$t_{DSW}$	Write Data Setup Time	100	-	-	ns
$t_{DHW}$	Write Data Hold Time	100	-	-	ns
$t_{CLKL}$	Clock Low Time	100	-	-	ns
$t_{CLKH}$	Clock High Time	100	-	-	ns
$t_R$	Rise Time	-	-	15	ns
$t_F$	Fall Time	-	-	15	ns

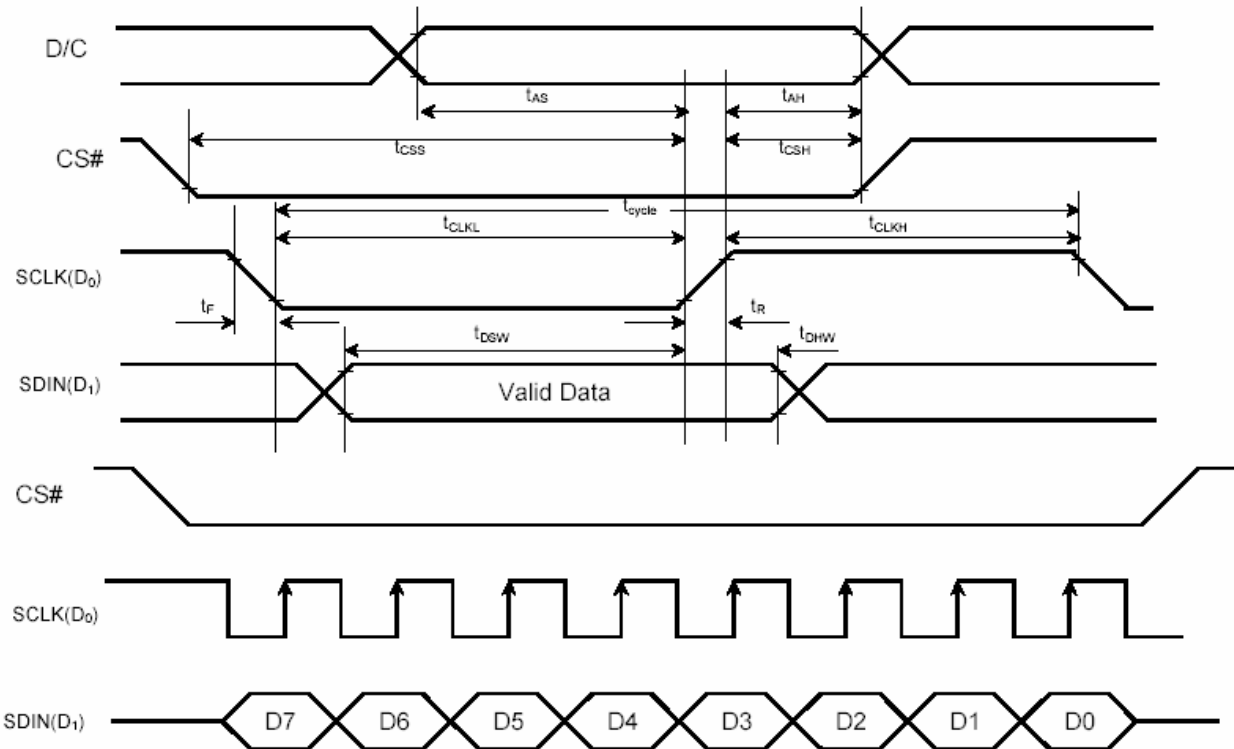

Serial interface characteristics

## 10 Display Control Instruction

Command table (D/C =0, R/W (WR#)=0, E (RD#)=1)

Bit Pattern	Command	Description
0000 X <sub>3</sub> X <sub>2</sub> X <sub>1</sub> X <sub>0</sub>	Set Lower Column Address **	Set the lower nibble of the column address register using X <sub>3</sub> X <sub>2</sub> X <sub>1</sub> X <sub>0</sub> as data bits. The initial display line register is reset to 0000b after POR.
0001 X <sub>3</sub> X <sub>2</sub> X <sub>1</sub> X <sub>0</sub>	Set Higher Column Address **	Set the higher nibble of the column address register using X <sub>3</sub> X <sub>2</sub> X <sub>1</sub> X <sub>0</sub> as data bits. The initial display line register is reset to 0000b after POR.
00101111	Activate horizontal scroll	Start horizontal scrolling
00101110	Deactivate horizontal scroll	Stop horizontal scrolling
01001100 A[2:0] B[2:0] C[1:0] D[2:0]	Horizontal scroll setup	A[2:0] Set the number of column scroll per step Valid value: 001b, 010b, 011b, 100b B[2:0] Define start page address C[1:0] Set time interval between each scroll step in terms of frame frequency 00b – 12 frame 01b – 64 frames 10b – 128 frames 11b – 256 frames D[2:0] Define end page address Set the value of D[2:0] larger or equal to B[2:0]
10000001 A[7:0]	Set Contrast Control Register **	Double byte command to select 1 out of 256 contrast steps. Contrast increases as the value increases. (POR = 80h)
1010010X <sub>0</sub>	Set Entire Display ON/OFF **	X <sub>0</sub> =0: normal display (POR) X <sub>0</sub> =1: entire display ON
1010011X <sub>0</sub>	Set Normal/Inverse Display **	X <sub>0</sub> =0: normal display (POR) X <sub>0</sub> =1: inverse display
10101000 A[5:0]	Set Multiplex Ratio **	The next command, A[5:0] determines multiplex ratio N from 16MUX-64MUX, POR= 64MUX
1010111X <sub>0</sub>	Set Display ON/OFF **	X <sub>0</sub> =0: turns OFF OLED panel (POR) X <sub>0</sub> =1: turns ON OLED panel
1011 X <sub>3</sub> X <sub>2</sub> X <sub>1</sub> X <sub>0</sub>	Set Page Address **	Set GDDRAM Page Address (0~7) for read/write using X <sub>3</sub> X <sub>2</sub> X <sub>1</sub> X <sub>0</sub>
1100X <sub>3</sub> * * *	Set COM Output Scan Direction	X <sub>3</sub> =0: normal mode (POR) Scan

	**	from COM 0 to COM [N –1] X3=1: remapped mode. Scan from COM [N-1] to COM0 Where N is the Multiplex ratio.
11010011 A[5:0]	Set Display Offset **	Set vertical scroll by COM from 0-63. The value is reset to 00H after POR.
11011001 X7X6X5X40010	Set Pre-charge period	Set length of pre-charge period in number of DCLK Default value of X7X6X5X4 is 0010b
11011010 000X40010	Set COM pins hardware configuration	X4=0, Sequential COM pin configuration (i.e. COM31, 30, 29...0 ; SEG0-132; COM31,32....62,63) X4=1(POR), Alternative COM pin configuration (i.e. COM62,60,58,...2,0; SEG0-132;COM1,3,5...61,6 3)
11100010	Reserved	Reserved
11100011	NOP **	Command for No Operation

**Note:** POR mean is power on reset.

### 11 Graphic Display Data Ram Address Map

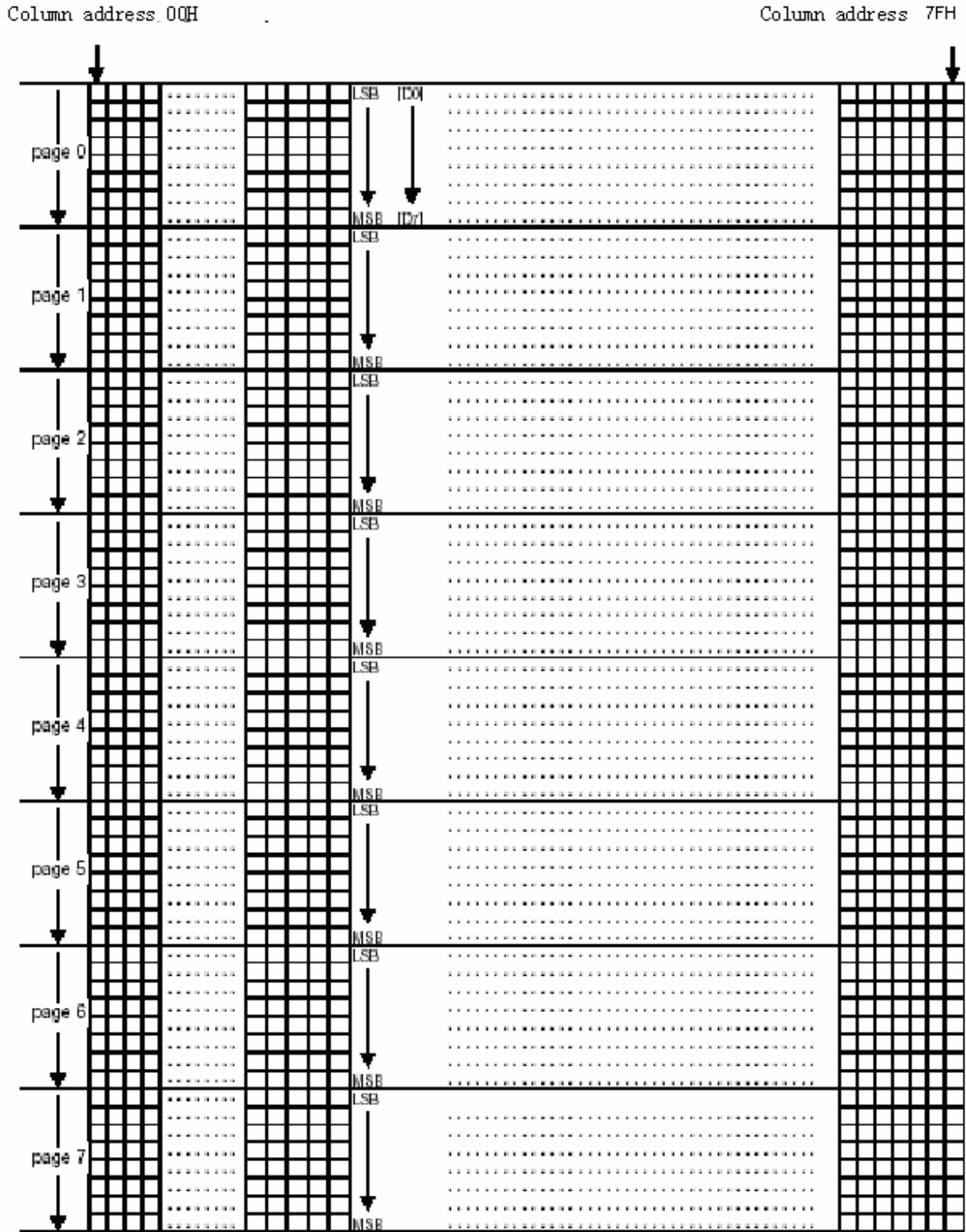

## 12 Precautions for operation and Storage

### 12.1 Precautions for Operation

- (1) Since OLED panel is made of glass, in order to prevent from glass broken, please do not apply any mechanical shock or impact or excessive force to it when installing the OLED module. Any strong mechanical impact due to falling dropping etc. may cause damage (breakage or cracking).
- (2) The polarizer on the OLED surface is made of soft material and is easily scratched. Please take most care when handing.
- (3) If OLED surface is contaminated, please wipe it off gently by using moisten soft cloth with normal ethanol, do not use acetone, ketone, isopropyl alcohol or water. If there is saliva or water on the OLED surface, please wipe it off immediately.
- (4) When handling OLED module, please be sure that the body and the tools are properly rounded. And do not touch I/O pins with bare hands or contaminate I/O pins, it will cause disconnection or defective insulation of terminals.
- (5) Do not attempt to disassemble or process the OLED module.
- (6) OLED module should be used under recommended operating conditions shown in the specification. Since the higher voltage leads to the shorter lifetime, be sure to use the specified operating voltage.
- (7) Foggy dew, moisture condensation or water droplets deposited on surface and contact terminals will cause polarizer stain or damage, the deteriorated display quality and electrochemical reaction then leads to the shorter life time and permanent damage to the module probably. Please pay attention to the environmental temperature and humidity.

### 12.2 Soldering

- (1) Use the high quality solder. (60-63% tin mixed with lead)
- (2) Iron: no higher than 260 and less than 3~4 sec during soldering.
- (3) Soldering: only to the I/O terminals.
- (4) Rewiring: no more than 3 times.

### 12.3 Precautions for Storage

- (1) Please store OLED module in a dark place, avoid exposure to sunlight, the light of fluorescent lamp or any ultraviolet ray.
- (2) Keep the environment temperature at between 10°C and 35°C and the relative humidity less than 60%. Avoid high temperature, high humidity.
- (3) That keeps the OLED modules stored in the container shipped from supplier before using them is recommended.
- (4) Do not leave any article on the OLED module surface for an extended period of time.

### 12.4 Warranty period

We warrants for a period of 12 months from the shipping date when stored or used under normal condition

---

## 12.5 Test Status

TEST ITEM	TEST CONDITION	QUANTITY
High temperature (storage)	70°C,240 hours	3pcs
Humidity (storage)	+85°C, 100%RH, 24hours	3pcs
Low temperature (storage)	- 50 ,120 hours	3pcs
Low temperature (operating)	-45°C, 120 hours	2pcs
High temperature (operating)	80°C, 120hours	2pcs

Note: After test 2 hours (room temperature), check function & appearance.