



FORMIKE ELECTRONIC CO.,LTD

PRDUCT SPECIFICATON

MONO LCD MODULE

MODEL : WG3224M2FSW6B VER:B

【 】 Preliminary Specification

【◆】 Finally Specification

CUSTOMER'S APPROVAL	
SIGNATURE:	DATE:

APPROVED BY	PM REVIEWD	PD REVIEWD	PREPARED BY
Meng Lin	Li tong	Zhengjinrong	Li Fei

Prepared By :

FORMIKE ELECTRONIC CO.,LTD

Address : A909, Huaying Building, 97 Nanshang Road,Nanshan District, Shenzhen, China.518054

TEL:(86) 755 88306921,88306931 FAX:(86) 755 88304615

Http:// www.wandisplay.com

- This specification is subject to change withouth notice.Please contact FORMIKE or it's representative before designing your product based on this specification.

Issued Date : Mar-03-2008

Revision history

revision	date	description	remark
A00	2008-02-29	First release	
B00	2008-03-03	Second release	Pin assignment

Content

1. Feature	1
2. Mechanical specifications	1
3. Block diagram & power supply	2
4. Pin description	2
5. Absolute maximum rating	3
6. Electrical characteristics	3
DC characteristics	3
AC characteristics	4
7. Backlight characteristics	5
8. Electrical-optical characteristics	6
9. Control and display commands	8
10. Inspection standards	9
11. Reliability test	10
12. Handling precautions	10

1. Feature

Display resolution	: 320(w)*240(h)
Display mode	: FSTN , Positive , transfective
Driving method	: 1/240 duty , 1/16 bias
Viewing direction	: 6 o'clock
Backlight	: LED , White
Built-in controller	: SED1335(or equivalence)
Operation temp	: -20°C~70°C
Storage temp	: -30°C~80°C

2. Mechanical Specifications

Dimensional outline (W*H*T)	: 160.0mm*109.0mm*13.5mm
Viewing area (W*H)	: 122.0mm*92.0mm
Dot pitch (W*H)	: 0.36mm*0.36mm
Dot size (W*H)	: 0.33mm*0.33mm
Weight	: Approx

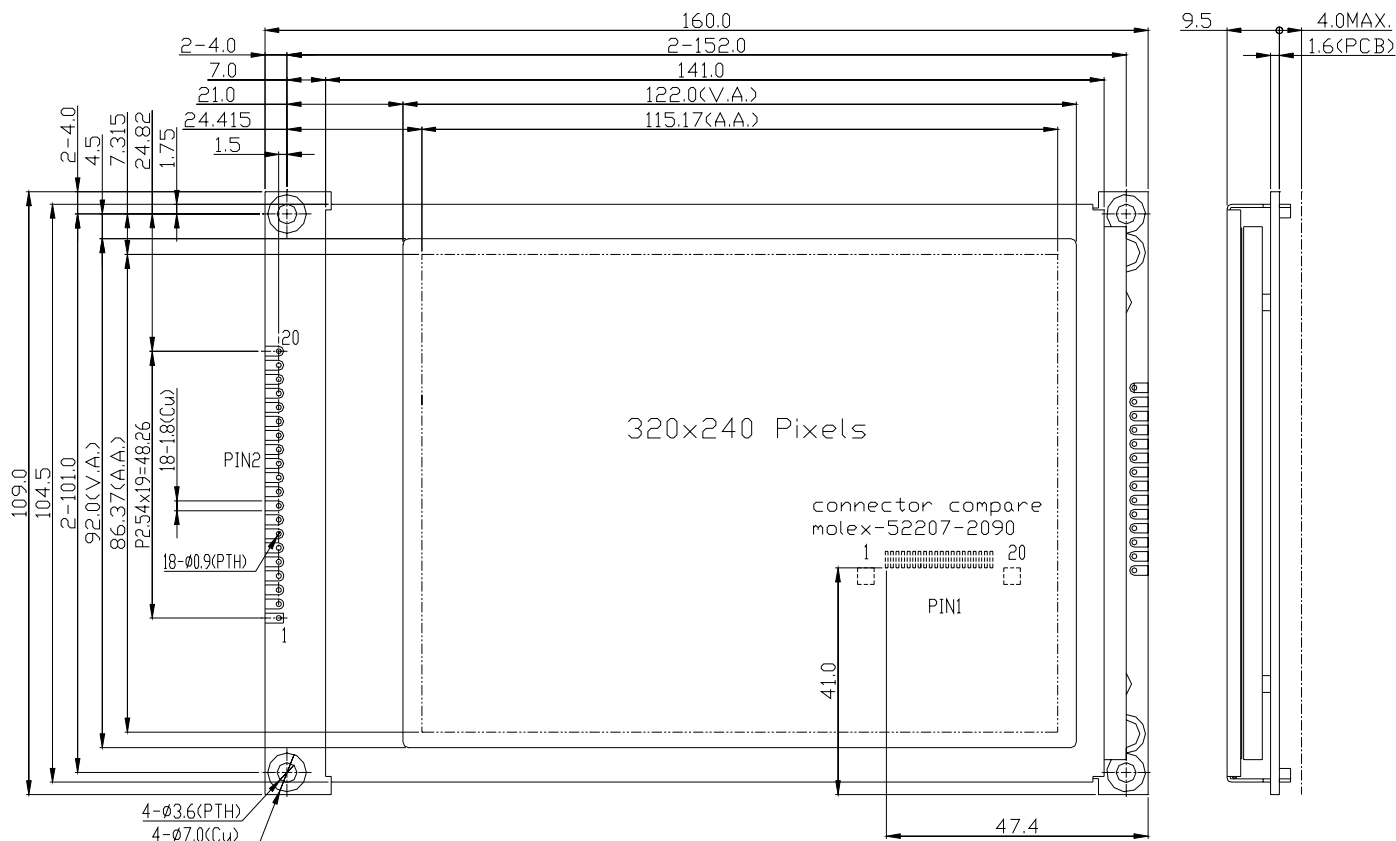

outline dimension

3. Block Diagram & Power supply

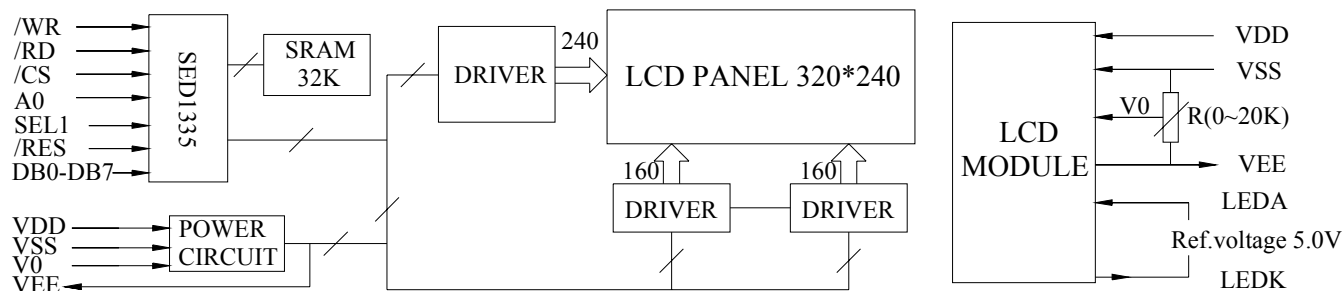

4. Pin description

PIN1

Pin No.	Pin Name	Function
1	VSS	Ground for logic
2	VDD	Power supply for logic
3	V0	Power supply for LCD driver
4	A0	Register selection (H : instruction register ; L : data register)
5	/WR	Read/write signal (H :read ; L : write)
6	/RD	Read/write signal (H :read ; L : write)
7~14	DB0~DB7	Data bus
15	/CS	Chip enable signal for ic1 (left half of the panel)
16	RST	Reset signal (Low effective)
17	Vee (NC)	Negative voltage output (NC)
18	SEL1	8080/6800 interface selection
19	FGND	Frame ground
20	LEDA	Power supply for backlight+

PIN2

Pin No.	Pin Name	Function
1	VSS	Ground for logic
2	VDD	Power supply for logic
3	V0	Power supply for LCD driver
4	/Wr	Read/write signal (H :read ; L : write)
5	/RD	Read/write signal (H :read ; L : write)
6	/CS	Chip enable signal for ic1 (left half of the panel)
7	A0	Register selection (H : data register ; L : instruction register)
8	RST	Reset signal (Low effective)
9~16	DB0~DB7	Data bus
17	NC	No connection
18	VOOUT (NC)	Negative voltage output (NC)
19	A	Power supply for backlight+
20	K	Power supply for backlight-

5. Absolute Maximum Ratings

Items	Symbol	MIN.	MAX.	Unit	Condition
Supply Voltage	V _{DD}	-0.3	+6.5	V	V _{SS} = 0V
	V _{lcd}	-0.3	+6.5	V	V _{SS} = 0V
Input Voltage	V _{IN}	-0.3	V _{DD} +0.3	V	V _{SS} = 0V
LED forward current	I _f	0	200	mA	---
Operating Temperature	T _{OP}	-20	+70	°C	---
Storage Temperature	T _{st}	-30	+80	°C	---

6. Electrical Characteristics**6.1 DC Characteristics**(V_{SS} = 0V, V_{DD} = 5.0V ± 10%, T_a = -20~75°C)

Items	Symbol	MIN.	TYP.	MAX.	Unit
Operating Voltage	V _{DD}	4.5	5.0	5.5	V
Input High Voltage	V _{IH}	0.8V _{DD}	-	V _{DD}	V
Input Low Voltage	V _{IL}	0	-	0.2 V _{DD}	V
Output High Voltage	V _{OH}	0.8V _{DD}	-	V _{DD}	V
Output Low Voltage	V _{OL}	0	-	0.2 V _{DD}	V
Supply Current	I _{DD}	---	-	30	mA

6.2 AC Characteristics

8080 family interface timing

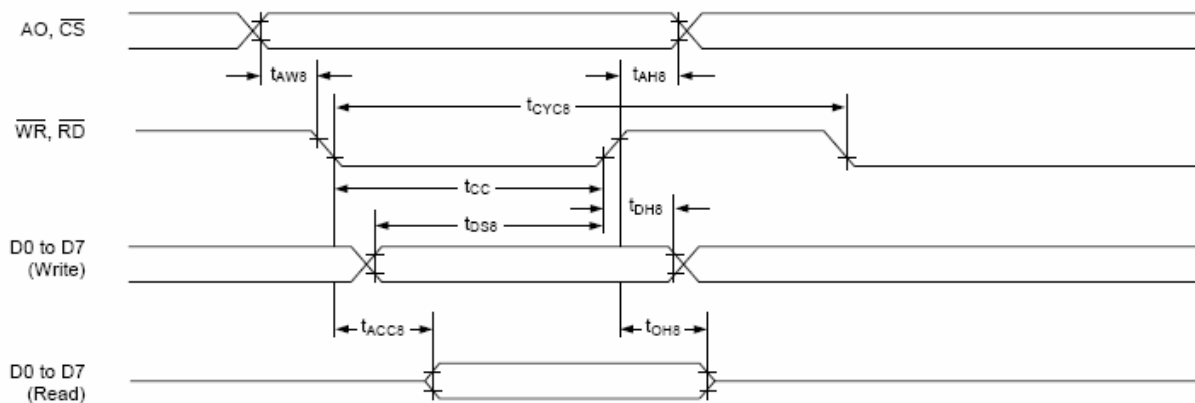

Ta = -20 to 75°C

Signal	Symbol	Parameter	VDD = 4.5 to 5.5V		VDD = 2.7 to 4.5V		Unit	Condition
			min	max	min	max		
A0, \overline{CS}	tAH8	Address hold time	10	—	10	—	ns	CL = 100pF
	tAW8	Address setup time	0	—	0	—	ns	
$\overline{WR}, \overline{RD}$	tCYC8	System cycle time	See note.	—	See note.	—	ns	
	tCC	Strobe pulsewidth	120	—	150	—	ns	
D0 to D7	tDS8	Data setup time	120	—	120	—	ns	
	tDH8	Data hold time	5	—	5	—	ns	
	tACC8	\overline{RD} access time	—	50	—	80	ns	
	tOH8	Output disable time	10	50	10	55	ns	

Note: For memory control and system control commands:

$$t_{CYC8} = 2t_c + t_{CC} + t_{CEA} + 75 > t_{ACV} + 245$$

For all other commands:

$$t_{CYC8} = 4t_c + t_{CC} + 30$$

6800 family interface timing

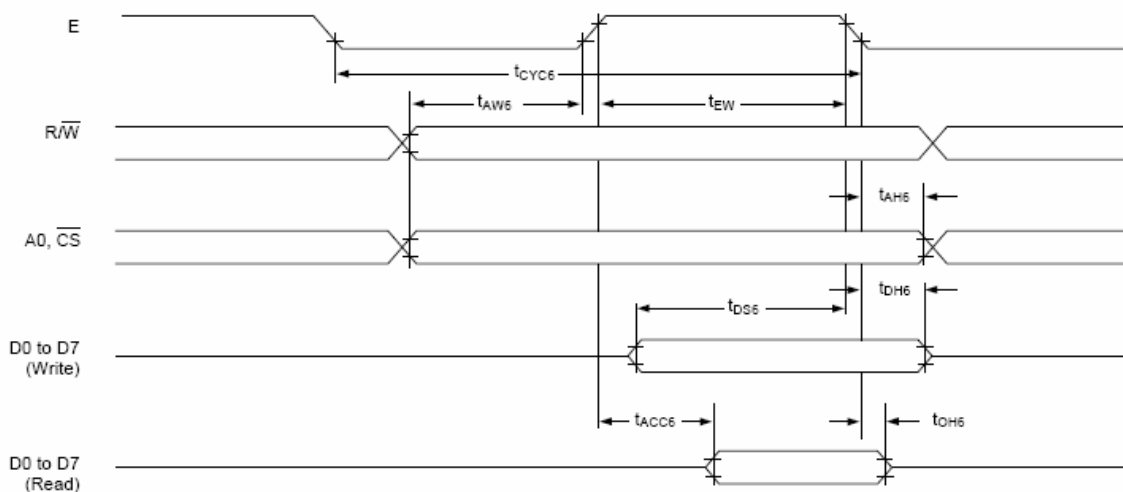

Note: t_{CYC6} indicates the interval during which CS is LOW and E is HIGH.

$T_a = -20$ to 75°C

Signal	Symbol	Parameter	VDD = 4.5 to 5.5V		VDD = 2.7 to 4.5V		Unit	Condition
			min	max	min	max		
A0, CS, R/W	t_{CYC6}	System cycle time	See note.	—	See note.	—	ns	CL = 100 pF
	t_{AW6}	Address setup time	0	—	10	—	ns	
	t_{AH6}	Address hold time	0	—	0	—	ns	
D0 to D7	t_{DS6}	Data setup time	100	—	120	—	ns	
	t_{DH6}	Data hold time	0	—	0	—	ns	
	t_{OH6}	Output disable time	10	50	10	75	ns	
	t_{ACC6}	Access time	—	85	—	130	ns	
E	t_{EW}	Enable pulsewidth	120	—	150	—	ns	

Note: For memory control and system control commands:

$$t_{CYC6} = 2t_c + t_{EW} + t_{CEA} + 75 > t_{ACV} + 245$$

For all other commands:

$$t_{CYC6} = 4t_c + t_{EW} + 30$$

7. Backlight Characteristics

Items	Symbol	MIN.	TYP.	MAX.	Unit	Condition
Forward Voltage	Vf	2.8	3.0	3.2	V	If=160mA
Reverse current	Ir	-	-	100	uA	Vr=5V
Peak wave length	λ	-	-	-	nM	If=160mA
Luminance	Lv	-	-	-	Cd/m ²	If=160mA
Color	White					

8. Electrical-Optical Characteristics

Items	Symbol	Condition	MIN.	TYP.	MAX.	Unit	NOTE
Operation Voltage	Vop	Ta= -20°C	25.2	25.5	25.8	V	1
		Ta= 25°C	24.7	25	25.3		
		Ta= 70°C	24.2	24.5	24.8		
Response time	Tr	Ta= 25°C	---	185	---	ms	2
	Tf		---	200	---		
Contrast ratio	Cr	Ta= 25°C	---	5	---	degree	3
Viewing angle range	θ	$Cr \geq 2; \Phi = 0^\circ$	-40	---	40		

Note1 Definition of Operation voltage

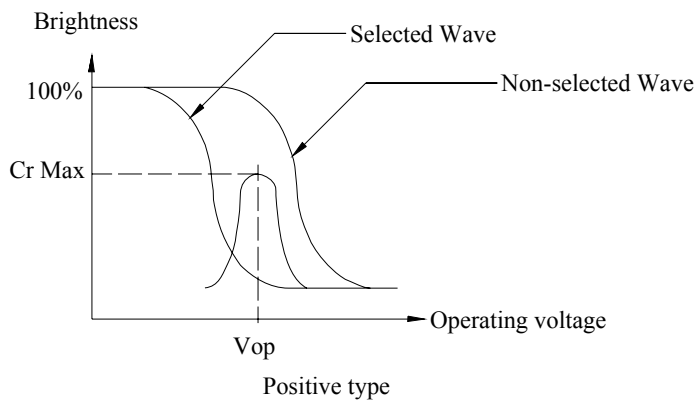

Note2 Definition of Response time

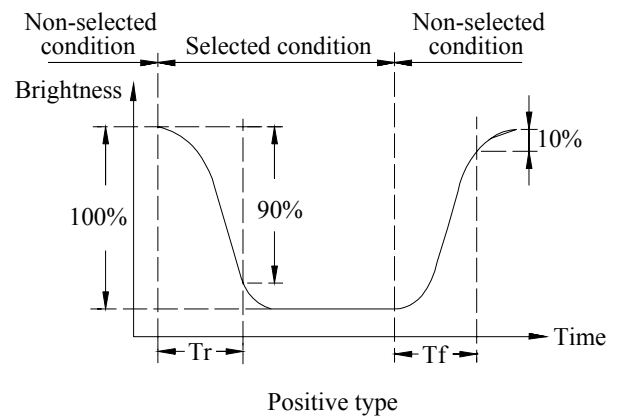

Note3 Definition of Contrast ratio、 Viewing angle and direction

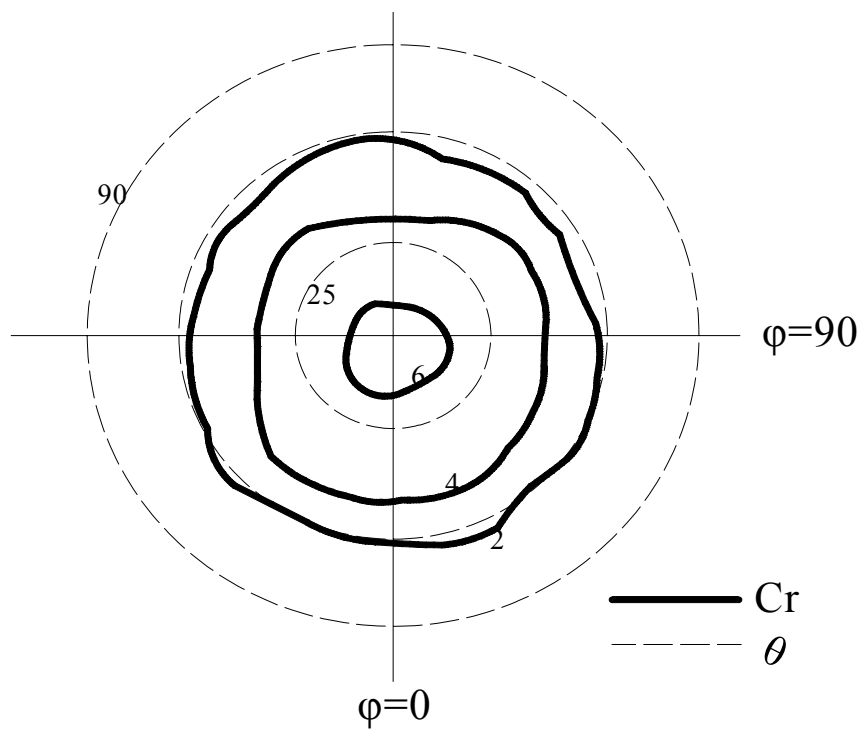
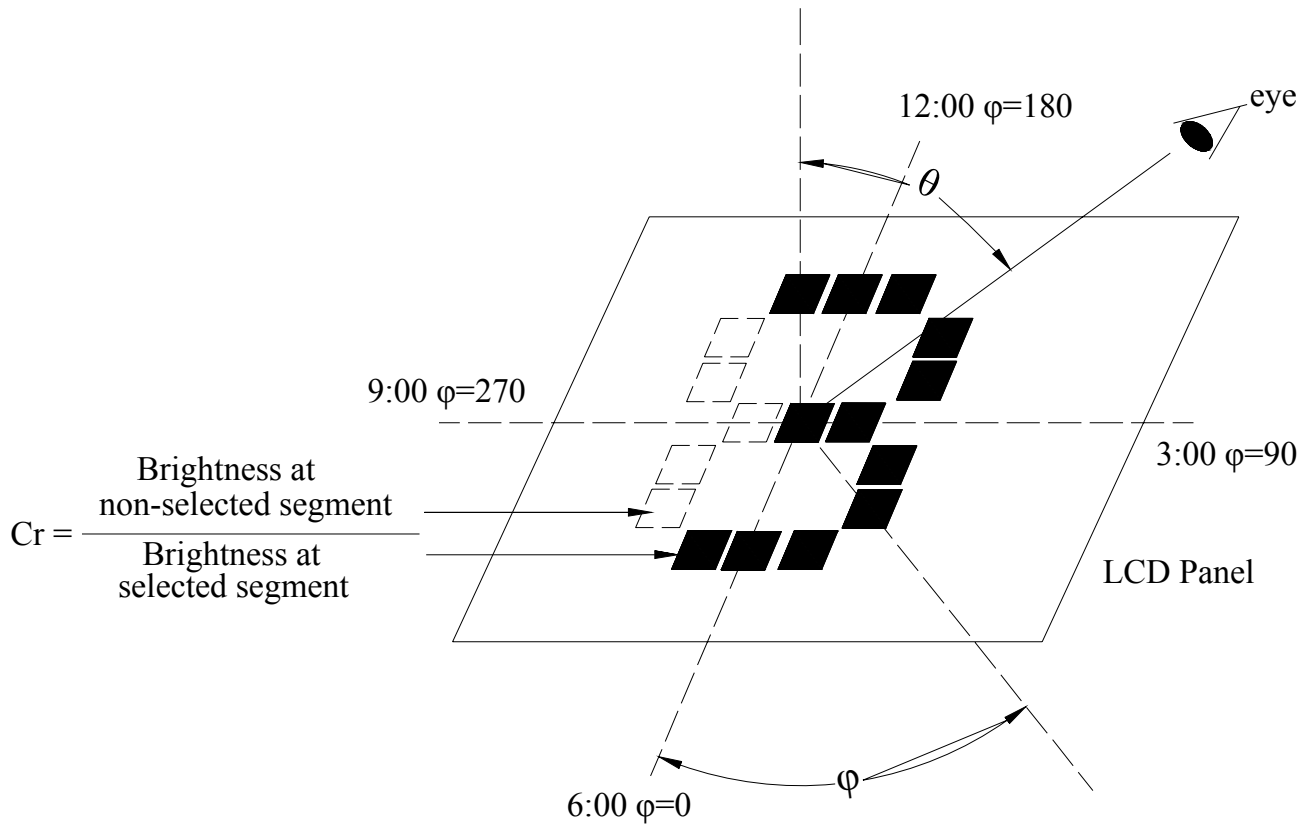

9. Control and display commands

Class	Command	Code											Hex	Command Description	Command Read Parameters	
		\overline{RD}	\overline{WR}	A0	D7	D6	D5	D4	D3	D2	D1	D0			No. of Bytes	Section
System control	SYSTEM SET	1	0	1	0	1	0	0	0	0	0	0	40	Initialize device and display	8	8.2.1
	SLEEP IN	1	0	1	0	1	0	1	0	0	1	1	53	Enter standby mode	0	8.2.2
Display control	DISP ON/OFF	1	0	1	0	1	0	1	1	0	0	D	58, 59	Enable and disable display and display flashing	1	8.3.1
	SCROLL	1	0	1	0	1	0	0	0	1	0	0	44	Set display start address and display regions	10	8.3.2
	CSRFORM	1	0	1	0	1	0	1	1	1	0	1	5D	Set cursor type	2	8.3.3
	CGRAM ADR	1	0	1	0	1	0	1	1	1	0	0	5C	Set start address of character generator RAM	2	8.3.6
	CSRDIR	1	0	1	0	1	0	0	1	1	CD 1	CD 0	4C to 4F	Set direction of cursor movement	0	8.3.4
	HDOT SCR	1	0	1	0	1	0	1	1	0	1	0	5A	Set horizontal scroll position	1	8.3.7
	OVLAY	1	0	1	0	1	0	1	1	0	1	1	5B	Set display overlay format	1	8.3.5
Drawing control	CSRW	1	0	1	0	1	0	0	0	1	1	0	46	Set cursor address	2	8.4.1
	CSRR	1	0	1	0	1	0	0	0	1	1	1	47	Read cursor address	2	8.4.2
Memory control	MWRITE	1	0	1	0	1	0	0	0	0	1	0	42	Write to display memory	—	8.5.1
	MREAD	1	0	1	0	1	0	0	0	0	1	1	43	Read from display memory	—	8.5.2

Notes:

- In general, the internal registers of the SED1335 series are modified as each command parameter is input. However, the microprocessor does not have to set all the parameters of a command and may send a new command before all parameters have been input. The internal registers for the parameters that have been input will have been changed but the remaining parameter registers are unchanged.
 - 2-byte parameters (where two bytes are treated as 1 data item) are handled as follows:
 - CSRW, CSRR: Each byte is processed individually. The microprocessor may read or write just the low byte of the cursor address.
 - SYSTEM SET, SCROLL, CGRAM ADR: Both parameter bytes are processed together. If the command is changed after half of the parameter has been input, the single byte is ignored.
- APL and APH are 2-byte parameters, but are treated as two 1-byte parameters.

10. Inspection Standards

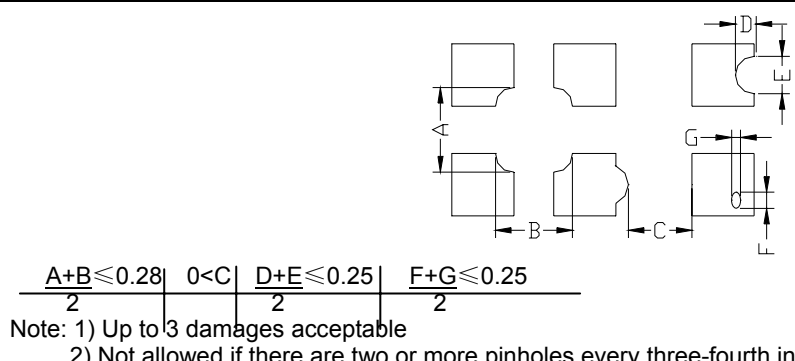
Item	Criterion for defects	Defect type
1) Display on inspection	(1) Non display (2) Vertical line is deficient (3) Horizontal line is deficient (4) Cross line is deficient	Major
2) Black / White spot	Size Φ (mm) Acceptable number $\Phi \leq 0.3$ Ignore (note) $0.3 < \Phi \leq 0.45$ 3 $0.45 < \Phi \leq 0.6$ 1 $0.6 < \Phi$ 0	Minor
3) Black / White line	Length (mm) Width (mm) Acceptable number $L \leq 10$ $W \leq 0.03$ Ignore $5.0 \leq L \leq 10$ $0.03 < W \leq 0.04$ 3 $5.0 \leq L \leq 10$ $0.04 < W \leq 0.05$ 2 $1.0 \leq L \leq 10$ $0.05 < W \leq 0.06$ 2 $1.0 \leq L \leq 10$ $0.06 < W \leq 0.08$ 1 $L \leq 10$ $0.08 < W$ follows 2) point defect Defects separate with each other at an interval of more than 20mm	Minor
4) Display pattern	 <p style="text-align: center;"> $\frac{A+B \leq 0.28}{2}$ $0 < C$ $\frac{D+E \leq 0.25}{2}$ $\frac{F+G \leq 0.25}{2}$ </p> <p>Note: 1) Up to 3 damages acceptable 2) Not allowed if there are two or more pinholes every three-fourth inch.</p>	Minor
5) Spot-like contrast irregularity	Size Φ (mm) Acceptable Number $\Phi \leq 0.7$ Ignore (note) $0.7 < \Phi \leq 1.0$ 3 $1.0 < \Phi \leq 1.5$ 1 $1.5 < \Phi$ 0 Note: 1) Conformed to limit samples. 2) Intervals of defects are more than 30mm.	Minor
6) Bubbles in polarizer	Size Φ (mm) Acceptable Number $\Phi \leq 0.4$ Ignore (note) $0.4 < \Phi \leq 0.65$ 2 $0.65 < \Phi \leq 1.2$ 1 $1.2 < \Phi$ 0	Minor
7) Scratches and dent on the polarizer	Scratches and dent on the polarizer shall be in the accordance with "2) Black/white spot", and "3) Black/White line".	Minor
8) Stains on the surface of LCD panel	Stains which cannot be removed even when wiped lightly with a soft cloth or similar cleaning.	Minor
9) Rainbow color	No rainbow color is allowed in the optimum contrast on state within the active area.	Minor
10) Viewing area encroachment	Polarizer edge or line is visible in the opening viewing area due to polarizer shortness or sealing line.	Minor
11) Bezel appearance	Rust and deep damages that are visible in the bezel are rejected.	Minor
12) Defect of land surface contact	Evident crevices that are visible are rejected.	Minor
13) Parts mounting	(1) Failure to mount parts (2) Parts not in the specifications are mounted (3) For example: Polarity is reversed, HSC or TCP falls off.	Minor
14) Part alignment	(1) LSI, IC lead width is more than 50% beyond pad outline. (2) More than 50% of LSI, IC leads is off the pad outline.	Minor
15) Conductive foreign matter (solder ball, solder hips)	(1) $0.45 < \Phi$, $N \geq 1$ (2) $0.3 < \Phi \leq 0.45$, $N \geq 1$, Φ : Average diameter of solder ball (unit: mm) (3) $0.5 < L$, $N \geq 1$, L: Average length of solder chip (unit: mm)	Minor
16) Bezel flaw	Bezel claw missing or not bent	Minor
17) Indication on name plate (sampling indication label)	(1) Failure to stamp or label error, or not legible.(all acceptable if legible) (2) The separation is more than 1/3 for indication discoloration, in which the characters can be checked.	Minor

11. Reliability test

item	condition	critierion
High temp. operation	80℃ 24hrs	No abnormality in function and appearance
High temp. storage	70℃ 24hrs	
Low temp. operation	-20℃ 24hrs	
Low temp. storage	-30℃ 24hrs	
Humidity	40℃ 90%RH 24hrs	
Thermal shock	0℃(30min)← →50℃(30min) 10cycles	
Vibration	Frequency :10~55HZ Duration : 3times , 3min/time Amplitude : 0.75mm	-

12. Handling precautions

1. Refrain from strong mechanical shock and forces to the module. It may cause improper operating or damage to the module.
2. The polarizer used on the display surface is easily scratched and damaged. Extreme care should be taken when handling. When cleaning the display surface, use soft cloth with a solvent recommended : ethyl alcohol , isopropyl or hexane) and wipe gently, do not use the following solvents : water, ketone or aromatics .
3. Wipe off water or oil drop immediately If you leave drop for a long time, stain and discoloration may occur.
4. Do not touch pads or pins of interface directly with bare hands. When handling the LCD module, put on a soft glover like finger-glover.
5. Protect the module from static electricity, it may cause damage to CMOS LSI.
6. To prevent LCD panels from degradation, do not operate or store them exposed directly to sunlight or high temperature/humidity.
7. If the liquid crystal leaks from the panel it should be kept away from the eyes and mouths. In case of contact with skins, wash away thoroughly with soap and water.
8. Soldering should be only performed on the I/O terminals within the temperature of $280 \pm 20^{\circ}\text{C}$ and soldering time should be less than 4 seconds.
9. Supply voltage within the specified voltage limit, the maximum rating, higher voltage cause the shorter LCD life or damaged.
10. Do not input any signals before power is turned on. Do not connect or disconnect the module on the state of Power-ON.