



**MULTI-INNO TECHNOLOGY CO., LTD.**

# **LCD MODULE SPECIFICATION**

**Model : MI9664B-G**

Revision	
Engineering	
Date	
Our Reference	



**REVISION RECORD**

<b>Date</b>	<b>Ver.</b>	<b>Ref. Page</b>	<b>Revision No.</b>	<b>Revision Items</b>
2003-9-8	1.0			Preliminary specification

**1. General Specifications:**

- 1.1 Display type: FSTN
- 1.2 Display color\*<sup>1</sup>:
  - Display color: Blue-Black
  - Background\*<sup>2</sup>: White
- 1.3 Polarizer mode: Transflective/Positive
- 1.4 Viewing Angle: 6:00
- 1.5 Driving Method: 1/65 Duty 1/9 Bias
- 1.6 Backlight: None
- 1.7 Controller: SSD1815BZ
- 1.8 Data Transfer: 8 Bit Parallel
- 1.9 Operating Temperature: -20----+70 °C
  - Storage Temperature: -30----+80 °C
- 1.10 VDD: 3.0V
- 1.11 LCD Operating Voltage: 9.0V
- 1.12 Outline Dimensions: Refer to outline drawing on next page
- 1.13 Dot Matrix: 96 X 64 Dots
- 1.14 Dot Size: 0.20 X 0.20(mm)
- 1.15 Dot Pitch: 0.22 X 0.22(mm)
- 1.16 Weight: Approx 5g

\*<sup>1</sup> Color tone is slightly changed by temperature and driving voltage.

\*<sup>2</sup> Color tone will be changed by backlight.

## 2. Outline Drawing

### 2.1 Outline Drawing of LCM

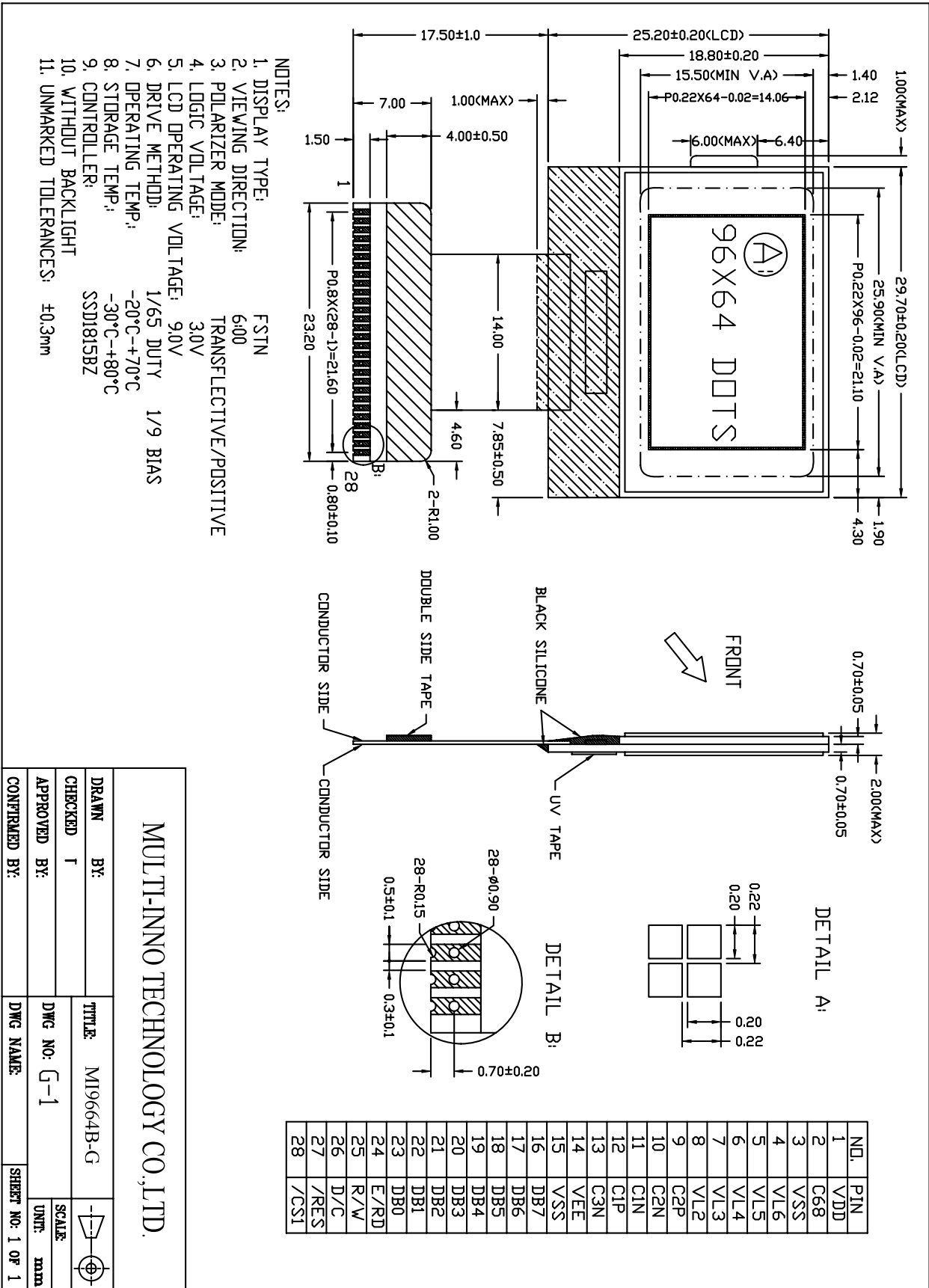



### 3. LCD Module Part Numbering System

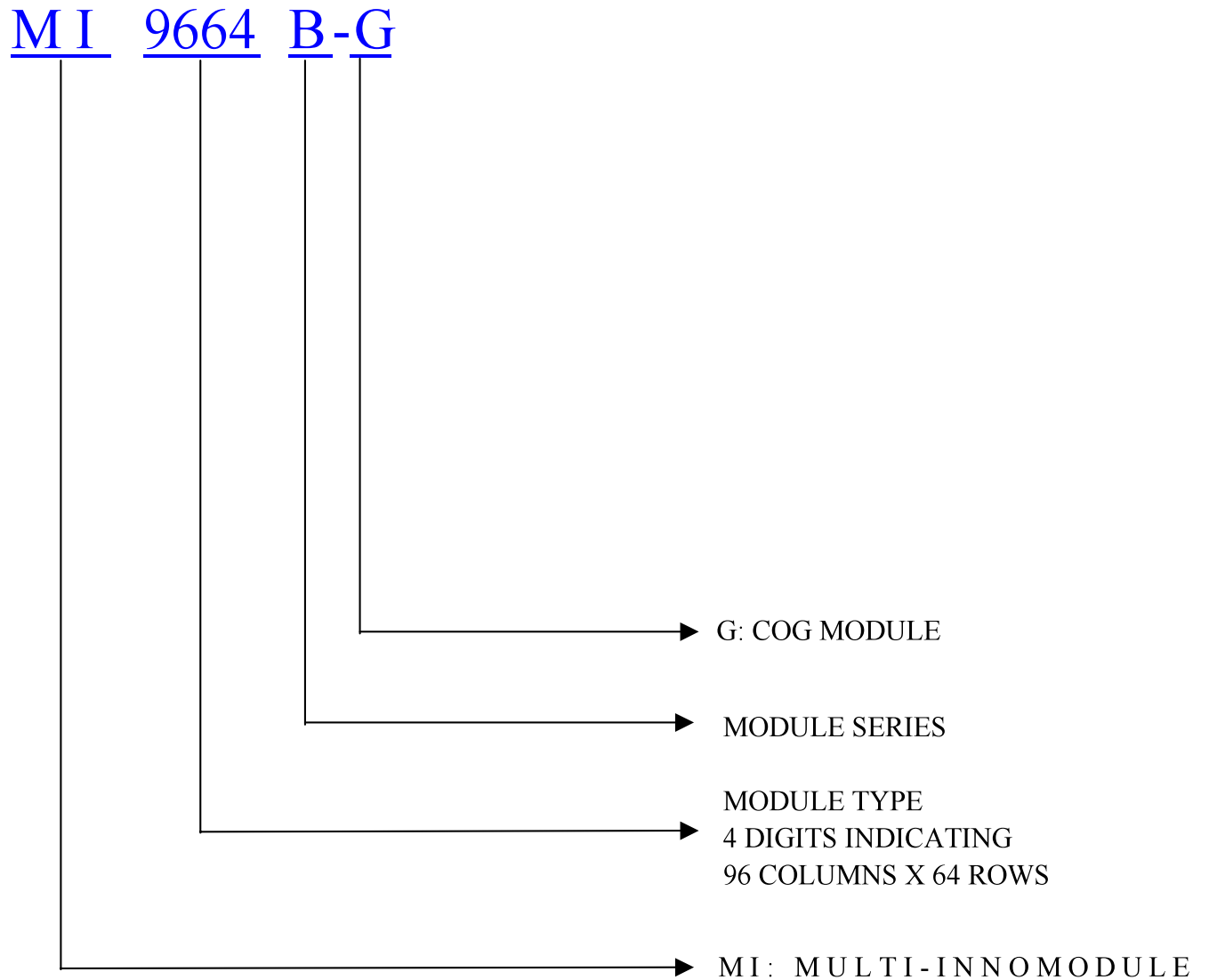

## 4. Circuit Block Diagram

### 4.1 Circuit Block Diagram

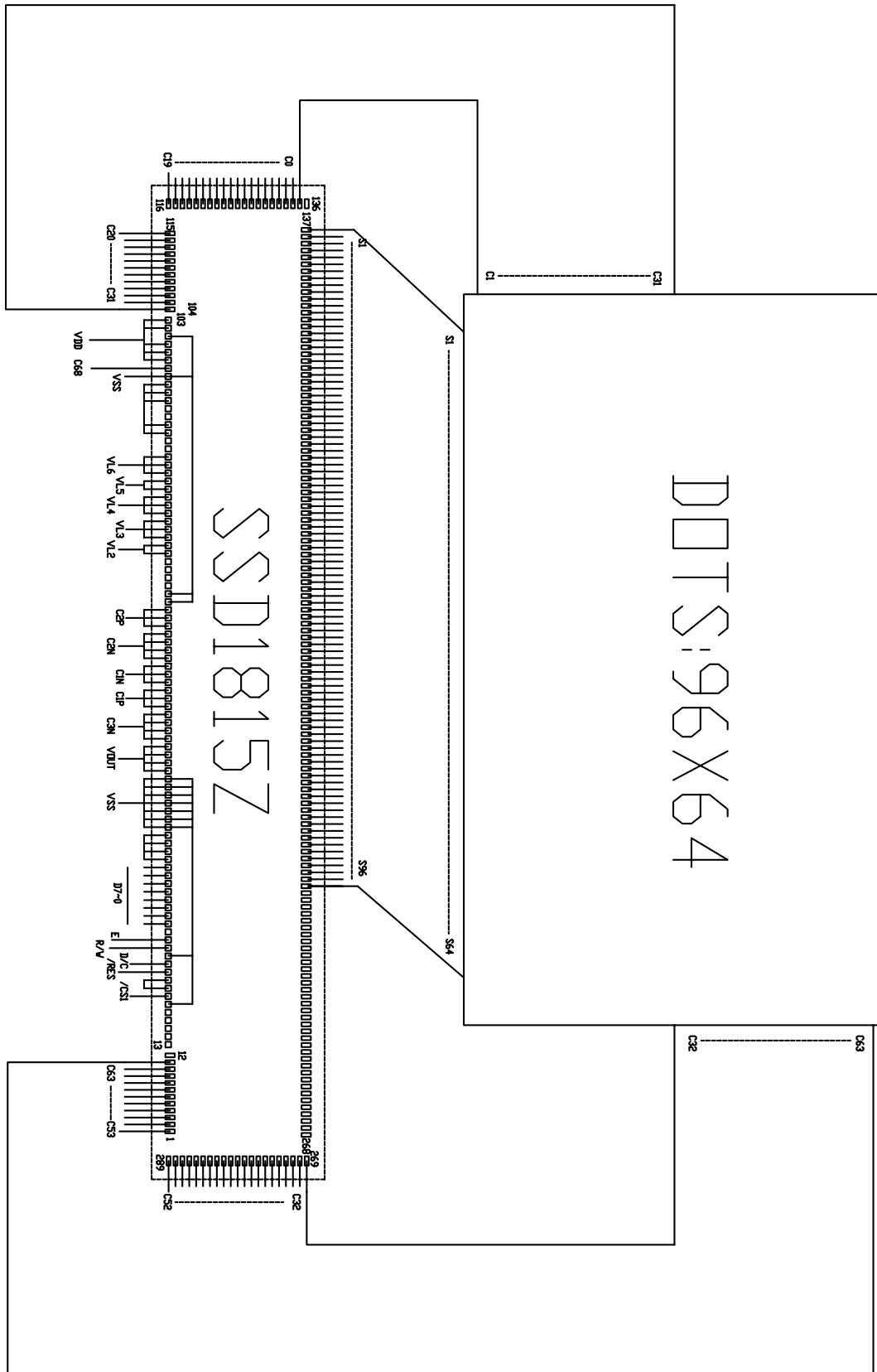

## 4.2 Power Supply Circuit

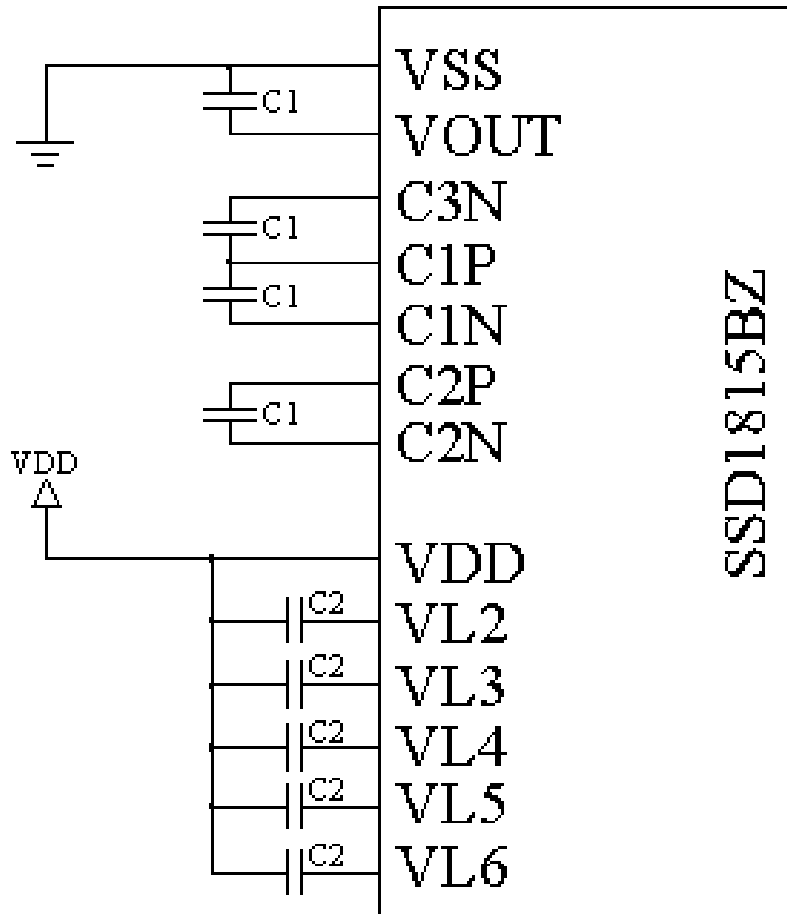

Reference Value: VDD=3.0V

C1=0.47~1.0uF/25V

C2=0.1~0.47uF/25V



---

### 5. Absolute Maximum Ratings

Item	Symbol	Min.	Max.	Unit	Remark
Power Supply Voltage	$V_{DD}-V_{SS}$	-0.3	4.0	V	
LCD Driving Voltage	$V_{LCD}$	4.0	12.0		
Operating Temperature Range	$T_{OP}$	-20	+70	°C	No Condensation
Storage Temperature Range	$T_{ST}$	-30	+80		





## 6. Electrical Specifications and Instruction Code

### 6.1 Electrical characteristics

Item	Symbol	Min.	Typ.	Max.	Unit
Supply Voltage (Logic)	$V_{DD}-V_{SS}$	2.5	3.0	3.5	V
Supply Voltage (LCD Drive)	$V_{LCD}$	-	9.0	-	V
Input Signal Voltage	High $V_{IH}$ ( $V_{DD}=2.8$ )	$0.8V_{DD}$	-	$V_{DD}$	V
	Low $V_{IL}$ ( $V_{DD}=2.8$ )	0	-	$0.2 V_{DD}$	V
Supply current (Logic) (Display Character)	$I_{DD}$ ( $V_{DD}-V_{SS}=2.8$ )	-	-	300	uA



## 6.2 Interface Signals

Pin No.	Symbol	Level	Description
1	VDD	3.0V	Power supply for logic
2	C68	H/L	Interface selection input H:6800 series interface;L:8080 series interface
3	VSS	0V	Ground
4	VL6	-	Power supply voltage for LCD
5	VL5	-	Power supply voltage for LCD
6	VL4	-	Power supply voltage for LCD
7	VL3	-	Power supply voltage for LCD
8	VL2	-	Power supply voltage for LCD
9	C2P	-	Capacitor pin for voltage converter
10	C2N	-	Capacitor pin for voltage converter
11	C1N	-	Capacitor pin for voltage converter
12	C1P	-	Capacitor pin for voltage converter
13	C3N	-	Capacitor pin for voltage converter
14	VEE		The most negative voltage supply pin
15	VSS	0V	Ground
16	DB7	H/L	8-bit bi-directional data bus
17	DB6	H/L	8-bit bi-directional data bus
18	DB5	H/L	8-bit bi-directional data bus
19	DB4	H/L	8-bit bi-directional data bus
20	DB3	H/L	8-bit bi-directional data bus
21	DB2	H/L	8-bit bi-directional data bus
22	DB1	H/L	8-bit bi-directional data bus
23	DB0	H/L	8-bit bi-directional data bus
24	E/RD	H/L	Read enable clock input pin
25	R/W	H/L	Write enable clock input pin
26	D/C	H/L	Register select input pin (H: Data, L: control)
27	/RES	H/L	Reset Signal. "L" -The settings are initialized
28	/CS1	H/L	Chip select input pin (active at low)



### 6.3 Interface Timing Chart

**6800-Series MPU Parallel Interface Timing Characteristics** ( $V_{DD} - V_{SS} = 2.4$  to  $3.5V$ ,  $T_A = -30$  to  $85^\circ C$ )

Symbol	Parameter	Min	Typ	Max	Unit
$t_{cycle}$	Clock Cycle Time	300	-	-	ns
$t_{AS}$	Address Setup Time	0	-	-	ns
$t_{AH}$	Address Hold Time	0	-	-	ns
$t_{DSW}$	Write Data Setup Time	40	-	-	ns
$t_{DHW}$	Write Data Hold Time	15	-	-	ns
$t_{DHR}$	Read Data Hold Time	20	-	-	ns
$t_{OH}$	Output Disable Time	-	-	70	ns
$t_{ACC}$	Access Time	-	-	140	ns
$PW_{CSL}$	Chip Select Low Pulse Width (read)	120	-	-	ns
	Chip Select Low Pulse Width (write)	60	-	-	ns
$PW_{CSH}$	Chip Select High Pulse Width (read)	60	-	-	ns
	Chip Select High Pulse Width (write)	60	-	-	ns
$t_R$	Rise Time	-	-	15	ns
$t_F$	Fall Time	-	-	15	ns

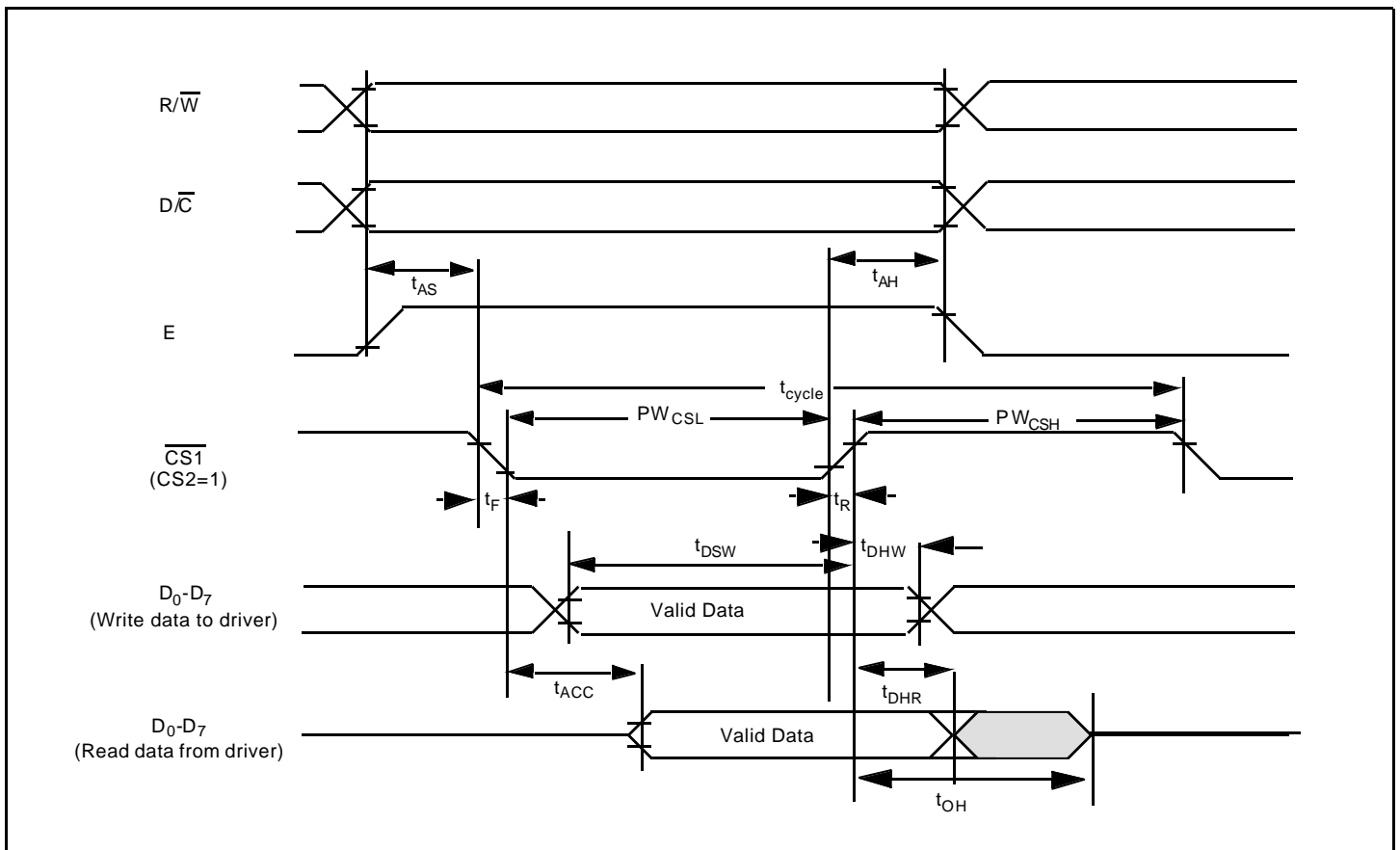

**6800-series MPU Parallel Interface Characteristics**



**8080-Series MPU Parallel Interface Timing Characteristics** ( $V_{DD} - V_{SS} = 2.4$  to  $3.5V$ ,  $T_A = -30$  to  $85^\circ C$ )

Symbol	Parameter	Min	Typ	Max	Unit
$t_{cycle}$	Clock Cycle Time	300	-	-	ns
$t_{AS}$	Address Setup Time	0	-	-	ns
$t_{AH}$	Address Hold Time	0	-	-	ns
$t_{DSW}$	Write Data Setup Time	40	-	-	ns
$t_{DHW}$	Write Data Hold Time	15	-	-	ns
$t_{DHR}$	Read Data Hold Time	20	-	-	ns
$t_{OH}$	Output Disable Time	-	-	70	ns
$t_{ACC}$	Access Time	-	-	140	ns
$PW_{CSL}$	Chip Select Low Pulse Width (read)	120	-	-	ns
	Chip Select Low Pulse Width (write)	60	-	-	ns
$PW_{CSH}$	Chip Select High Pulse Width (read)	60	-	-	ns
	Chip Select High Pulse Width (write)	60	-	-	ns
$t_R$	Rise Time	-	-	15	ns
$t_F$	Fall Time	-	-	15	ns

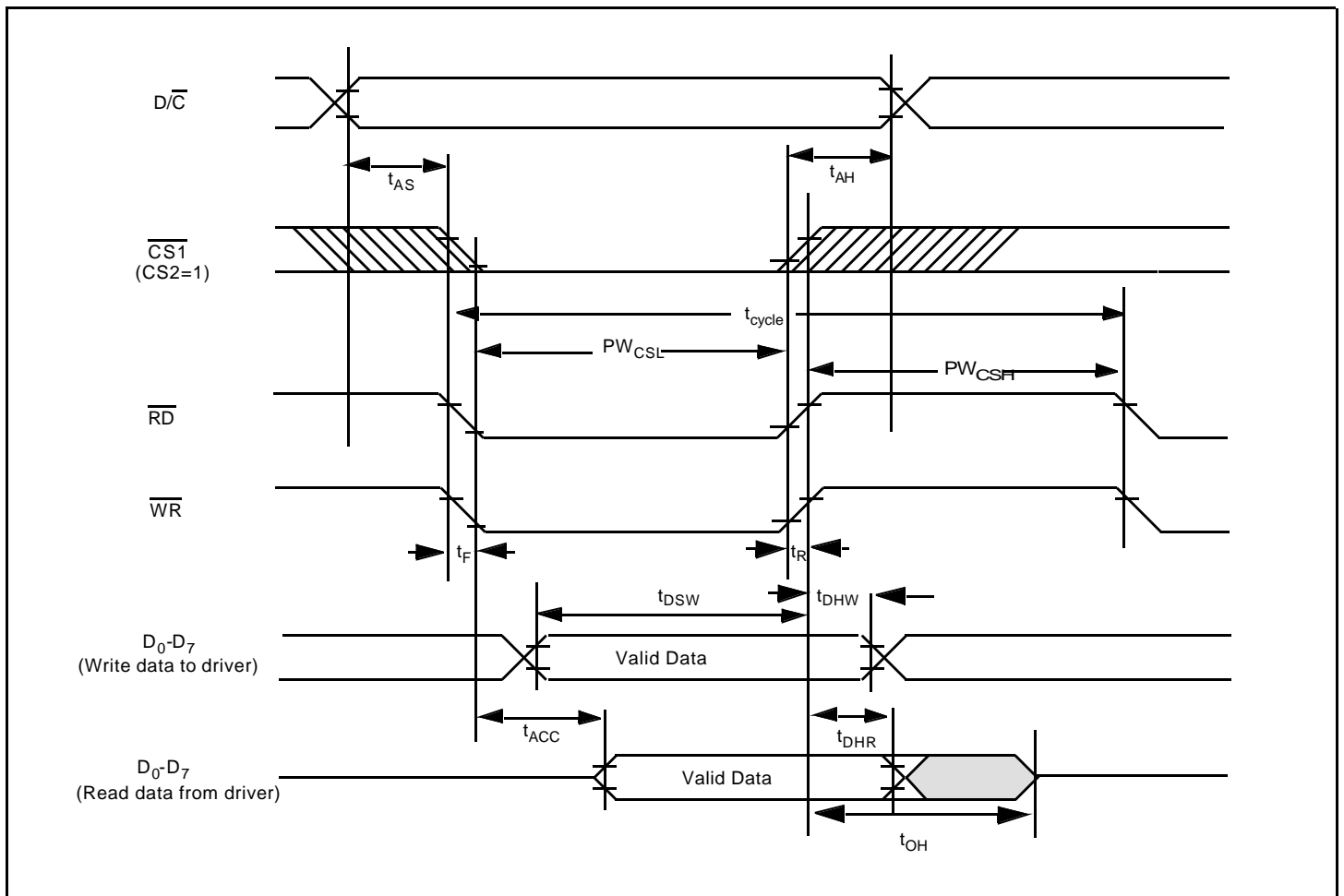

**8080-series MPU Parallel Interface Characteristics**



## 6.4 Instruction Code

Bit Pattern	Command	Description
0000X <sub>3</sub> X <sub>2</sub> X <sub>1</sub> X <sub>0</sub>	Set Lower Column Address	Set the lower nibble of the column address register using X <sub>3</sub> X <sub>2</sub> X <sub>1</sub> X <sub>0</sub> as data bits. The lower nibble of column address register is reset to 0000b after POR.
0001X <sub>3</sub> X <sub>2</sub> X <sub>1</sub> X <sub>0</sub>	Set Higher Column Address	Set the higher nibble of the column address register using X <sub>3</sub> X <sub>2</sub> X <sub>1</sub> X <sub>0</sub> as data bits. The higher nibble of column address is reset to 0000b after POR.
00100X <sub>2</sub> X <sub>1</sub> X <sub>0</sub>	Set Internal Regulator Resistor Ratio	Feedback gain of the internal regulator generating V <sub>L6</sub> increases as X <sub>2</sub> X <sub>1</sub> X <sub>0</sub> increased from 000b to 111b. After POR, X <sub>2</sub> X <sub>1</sub> X <sub>0</sub> = 100b.
00101X <sub>2</sub> X <sub>1</sub> X <sub>0</sub>	Set Power Control Register	X <sub>0</sub> =0: turns off the output op-amp buffer (POR) X <sub>0</sub> =1: turns on the output op-amp buffer X <sub>1</sub> =0: turns off the internal regulator (POR) X <sub>1</sub> =1: turns on the internal regulator X <sub>2</sub> =0: turns off the internal voltage booster (POR) X <sub>2</sub> =1: turns on the internal voltage booster
01X <sub>5</sub> X <sub>4</sub> X <sub>3</sub> X <sub>2</sub> X <sub>1</sub> X <sub>0</sub>	Set Display Start Line	Set GDDRAM display start line register from 0-63 using X <sub>5</sub> X <sub>4</sub> X <sub>3</sub> X <sub>2</sub> X <sub>1</sub> X <sub>0</sub> . Display start line register is reset to 000000 after POR.
10000001 ** X <sub>5</sub> X <sub>4</sub> X <sub>3</sub> X <sub>2</sub> X <sub>1</sub> X <sub>0</sub>	Set Contrast Control Register	Select contrast level from 64 contrast steps. Contrast increases (V <sub>L6</sub> decreases) as X <sub>5</sub> X <sub>4</sub> X <sub>3</sub> X <sub>2</sub> X <sub>1</sub> X <sub>0</sub> is increased from 000000b to 111111b. X <sub>5</sub> X <sub>4</sub> X <sub>3</sub> X <sub>2</sub> X <sub>1</sub> X <sub>0</sub> = 100000b after POR
1010000X <sub>0</sub>	Set Segment Re-map	X <sub>0</sub> =0: column address 00h is mapped to SEG0 (POR) X <sub>0</sub> =1: column address 83h is mapped to SEG0 Refer to Figure 8 on page 15 for example.
1010001X <sub>0</sub>	Set LCD Bias	X <sub>0</sub> =0: POR default bias: 1/9 X <sub>0</sub> =1: alternate bias: 1/7 For other bias ratio settings, see "Set 1/4 Bias Ratio" and "Set Bias Ratio" in Extended Command Set.
1010010X <sub>0</sub>	Set Entire Display On/Off	X <sub>0</sub> =0: normal display (POR) X <sub>0</sub> =1: entire display on
1010011X <sub>0</sub>	Set Normal/Reverse Display	X <sub>0</sub> =0: normal display (POR) X <sub>0</sub> =1: reverse display
1010111X <sub>0</sub>	Set Display On/Off	X <sub>0</sub> =0: turns off LCD panel (POR) X <sub>0</sub> =1: turns on LCD panel
1011X <sub>3</sub> X <sub>2</sub> X <sub>1</sub> X <sub>0</sub>	Set Page Address	Set GDDRAM Page Address (0-8) for read/write using X <sub>3</sub> X <sub>2</sub> X <sub>1</sub> X <sub>0</sub>
1100X <sub>3</sub> ***	Set COM Output Scan Direction	X <sub>3</sub> =0: normal mode (POR) X <sub>3</sub> =1: remapped mode, COM0 to COM[N-1] becomes COM[N-1] to COM0 when Multiplex ratio is equal to N. See Figure 8 on page 15 for detail mapping.
11100000	Set Read-Modify-Write Mode	Read-Modify-Write mode will be entered in which the column address will not be increased during display data read. After POR, Read-modify-write mode is turned OFF.
11100010	Software Reset	Initialize internal status registers.
11101110	Set End of Read-Modify-Write Mode	Exit Read-Modify-Write mode. RAM Column address before entering the mode will be restored. After POR, Read-modify-write mode is OFF.



## 7. Optical Characteristics

### 7.1 Optical Characteristics

Ta=25°C

Item	Symbol	Condition	Min.	Typ.	Max.	Unit
Viewing Angle	$\theta_x$	$C_r \geq 2$	-30	--	20	Deg
	$\theta_y$					
Contrast Ratio	$C_r$	$\theta_x = 0^\circ$ $\theta_y = 0^\circ$	3.0	-	-	
Response Time	Turn on	$\theta_x = 0^\circ$ $\theta_y = 0^\circ$	-	-	300	ms
	Turn off					

## 7.2 Definition of Optical Characteristics

### 7.2.1 Definition of Viewing Angle

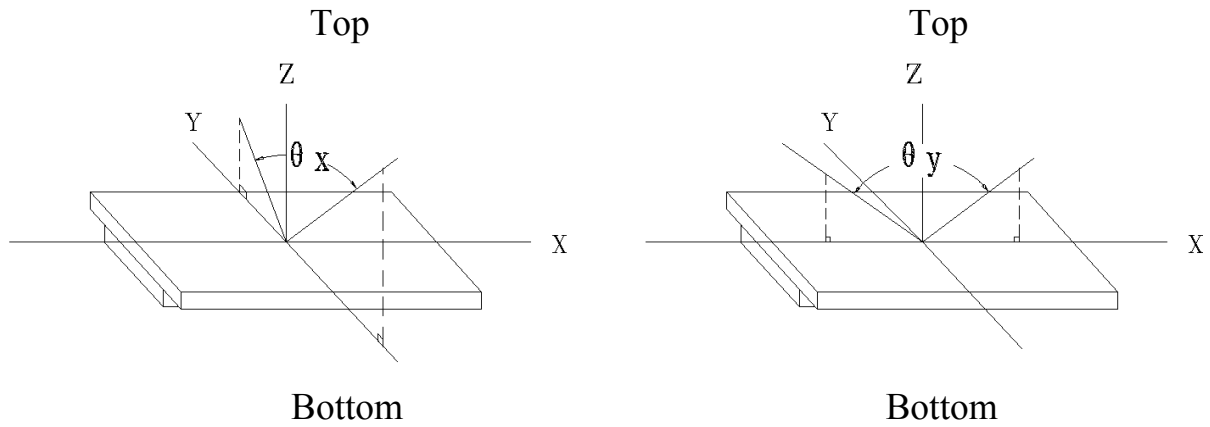

### 7.2.2 Definition of Contrast Ratio

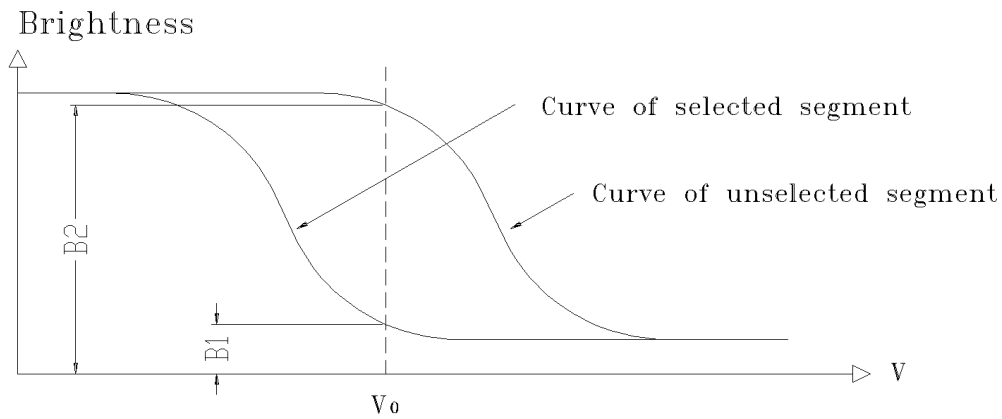

$$\text{Contrast Ratio} = B2/B1 = \frac{\text{unselected state brightness}}{\text{selected state brightness}}$$

Measuring Conditions:

- 1) Ambient Temperature: 25°C ;
- 2) Frame frequency: 84.0Hz

### 7.2.3 Definition of Response time

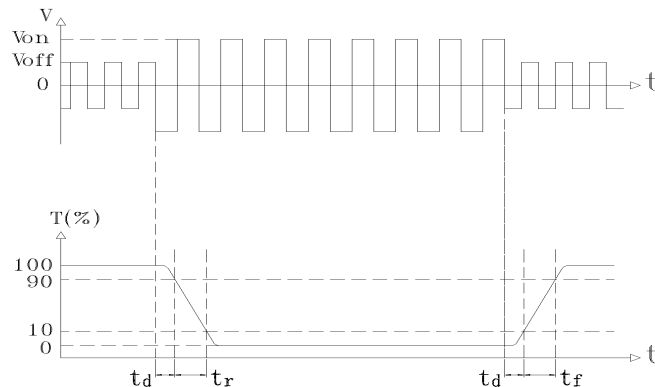

Turn on time:  $t_{on} = t_d + t_r$       Turn off time:  $t_{off} = t_d + t_f$

Measuring Condition:

- 1) Operating Voltage: 9.0V ;
- 2) Frame frequency: 84.0Hz

## 8. Reliability

### 8.1 Content of Reliability Test

Ta=25°C

No.	Test Item	Content of Test	Test condition
1	High Temperature Storage	Endurance test applying the high storage temperature for a long time	80°C 240H Restore 4H at 25°C
2	Low Temperature Storage	Endurance test applying the low storage temperature for a long time	-30°C 240H Restore 4H at 25°C
3	High Temperature /Humidity Storage	Endurance test applying the high temperature and high humidity storage for a long time	60°C 90%RH 240H Restore 4H at 25°C
4	Temperature Cycle	Endurance test applying the low and high temperature cycle $  \begin{array}{ccccccc}  -30^{\circ}\text{C} & \longleftrightarrow & 25^{\circ}\text{C} & \longleftrightarrow & 80^{\circ}\text{C} & \longleftrightarrow & 25^{\circ}\text{C} \\  30\text{min} & & 5\text{min} & & 30\text{min} & & 5\text{min} \\  \longleftarrow & & & & & & \longrightarrow \\  & & & & \text{1 cycle} & &   \end{array}  $	-30°C/80°C 10 cycles Restore 4H at 25°C
5	Vibration Test (package state)	Endurance test applying the vibration during transportation	10Hz~500Hz, 100m/s <sup>2</sup> , 120min
6	Shock Test (package state)	Endurance test applying the shock during transportation	Half- sine wave, 300m/s <sup>2</sup> , 18ms
7	Atmospheric Pressure Test	Endurance test applying the atmospheric pressure during transportation by air	25kPa 16H Restore 2H



## 8.2 Failure Judgment Criterion

Criterion Item	Test Item No.							Failure Judgement Criterion
	1	2	3	4	5	6	7	
Basic Specification	√	√	√	√	√	√	√	Out of the basic Specification
Electrical specification	√	√	√					Out of the electrical specification
Mechanical Specification					√	√		Out of the mechanical specification
Optical Characteristic	√	√	√	√			√	Out of the optical specification
Note	For test item refer to 8.1							
Remark	Basic specification = Optical specification + Mechanical specification							

## 9. QUALITY LEVEL

Examination or Test	At $T_a=25^\circ\text{C}$ (unless otherwise stated)	Inspection				
		Min.	Max.	Unit	IL	AQL
External Visual Inspection	Under normal illumination and eyesight condition, the distance between eyes and LCD is 25cm.	See Appendix A			II	Major 0.65 Minor 1.5
Display Defects	Under normal illumination and eyesight condition, display on inspection.	See Appendix B			II	Major 0.65 Minor 1.5
Note: Major defects: Open segment or common, Short, Serious damages, Leakage Miner defects: Others Sampling standard conforms to GB2828						

## 10. Precautions for Use of LCD Modules

### 10.1 Handling Precautions

10.1.1 The display panel is made of glass. Do not subject it to a mechanical shock by dropping it from a high place, etc.

10.1.2 If the display panel is damaged and the liquid crystal substance inside it leaks out, be sure not to get any in your mouth, if the substance comes into contact with your skin or clothes, promptly wash it off using soap and water.

10.1.3 Do not apply excessive force to the display surface or the adjoining areas since this may cause the color tone to vary.

10.1.4 The polarizer covering the display surface of the LCD module is soft and easily scratched. Handle this polarizer carefully.

10.1.5 If the display surface is contaminated, breathe on the surface and gently wipe it with a soft dry cloth. If still not completely clear, moisten cloth with one of the following solvents:

- Isopropyl alcohol
- Ethyl alcohol

Solvents other than those mentioned above may damage the polarizer. Especially, do not use the following:

- Water
- Ketone
- Aromatic solvents

10.1.6 Do not attempt to disassemble the LCD Module.

10.1.7 If the logic circuit power is off, do not apply the input signals.

10.1.8 To prevent destruction of the elements by static electricity, be careful to maintain an optimum work environment.

- a. Be sure to ground the body when handling the LCD Modules.
- b. Tools required for assembly, such as soldering irons, must be properly ground.
- c. To reduce the amount of static electricity generated, do not conduct assembly and other work under dry conditions.
- d. The LCD Module is coated with a film to protect the display surface. Be care when peeling off this protective film since static electricity may be generated.



## 10.2 Storage precautions

10.2.1 When storing the LCD modules, avoid exposure to direct sunlight or to the light of fluorescent lamps.

10.2.2 The LCD modules should be stored under the storage temperature range. If the LCD modules will be stored for a long time, the recommend condition is:

Temperature :  $0^{\circ}\text{C} \sim 40^{\circ}\text{C}$

Relatively humidity:  $\leq 80\%$

10.2.3 The LCD modules should be stored in the room without acid, alkali and harmful gas.

10.3 The LCD modules should be no falling and violent shocking during transportation, and also should avoid excessive press, water, damp and sunshine.

**Appendix A**

## Inspection items and criteria for appearance defects

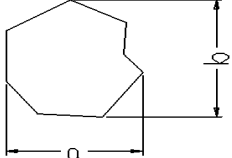
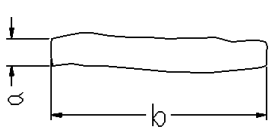
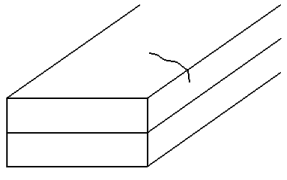
Items	Contents	Criteria			
Leakage		Not permitted			
Rainbow		According to the limit specimen			
Polarizer	Wrong polarizer attachment	Not permitted			
	Bubble between polarizer and glass	Not counted	Max. 3 defects allowed		
		$\phi < 0.3\text{mm}$	$0.3\text{mm} \leq \phi \leq 0.5\text{mm}$		
	Scratches of polarizer	According to the limit specimen			
Black spot (in viewing area)		Not counted	Max. 3 spots allowed	Max. 3 spots (lines) allowed	
		$X < 0.2\text{mm}$	$0.2\text{mm} \leq X \leq 0.5\text{mm}$		
		$X = (a+b)/2$			
Black line (in viewing area)		Not counted	Max. 3 lines allowed		
		$a < 0.02\text{mm}$	$0.02\text{mm} \leq a \leq 0.05\text{mm}$ $b \leq 2.0\text{mm}$		
Progressive cracks		Not permitted			

**Appendix A**

## Inspection item and criteria for appearance defects (continued)

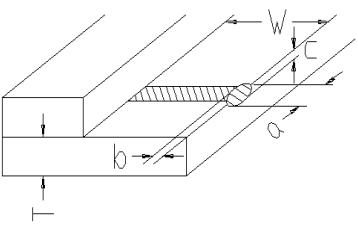
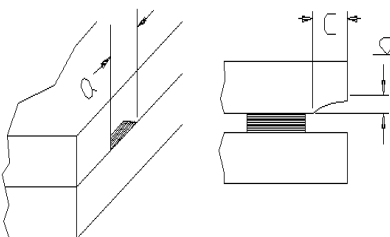
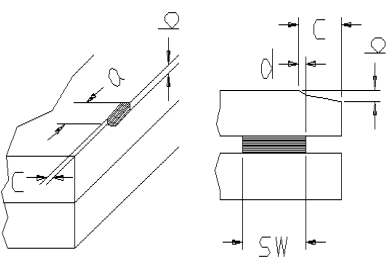
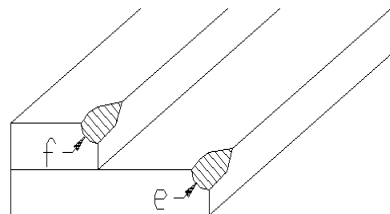
Items	Contents	Criteria			
		a	b	c	
Glass Cracks	Cracks on pads 	$\leq 3\text{mm}$	$\leq W/5$	$\leq T/2$	Max. 2 cracks allowed
	$\leq 2\text{mm}$	$\leq W/5$	$T/2 < C < T$		
	Cracks on contact side 	$\leq 3\text{mm}$	$\leq T/2$	C shall be not reach the seal area	Max. 2 cracks allowed
	$\leq 2\text{mm}$	$T/2 < b < T$			
	Cracks on non-contact side 	$\leq 3\text{mm}$	$\leq T/2$	$T/2 < b < T$	
	$\leq 2\text{mm}$				
		$C \leq 0.5\text{mm}$			
		$d \leq SW/3$			
	Corner cracks 	$e < 2.0\text{mm}^2$ $f < 2.0\text{mm}^2$		Max. 3 cracks allowed	

Max. 5 cracks allowed

**Appendix B**

## Inspection items and criteria for display defects

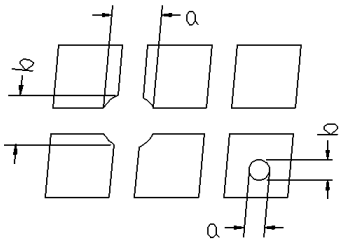
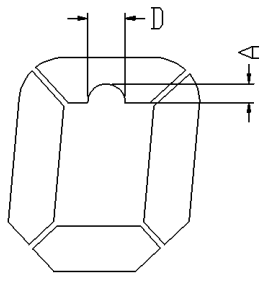
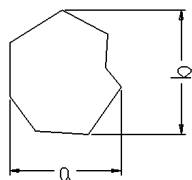
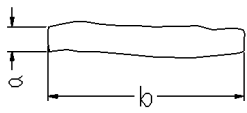
Items	Contents	Criteria		
Open segment or open common		Not permitted		
Short		Not permitted		
Wrong viewing angle		Not permitted		
Contrast ratio uneven		According to the limit specimen		
Crosstalk		According to the limit specimen		
Pin holes and cracks in segment (DOT)		Not counted	Max.3 dots allowed	Max.3 dots allowed
		$X < 0.1\text{mm}$	$0.1\text{mm} \leq X \leq 0.2\text{mm}$	
		$X = (a+b)/2$		
		Not counted	Max.2 dots allowed	
		$A < 0.1\text{mm}$	$0.1\text{mm} \leq A \leq 0.2\text{mm}$ $D < 0.25\text{mm}$	
Black spot (in viewing area)		Not counted	Max.3 spots allowed	Max.3 spots (lines) allowed
		$X < 0.1\text{mm}$	$0.1\text{mm} \leq X \leq 0.2\text{mm}$	
		$X = (a+b)/2$		
Black line (in viewing area)		Not counted	Max.3 lines allowed	
		$a < 0.02\text{mm}$	$0.02\text{mm} \leq a \leq 0.05\text{mm}$ $b \leq 0.5\text{mm}$	

**Appendix B**

## Inspection items and criteria for display defects (continued)

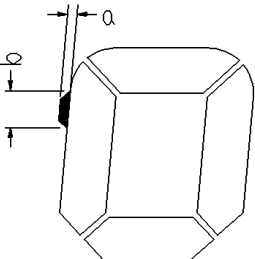
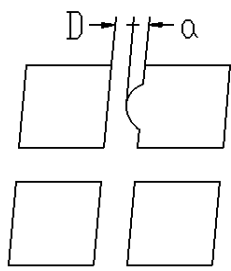
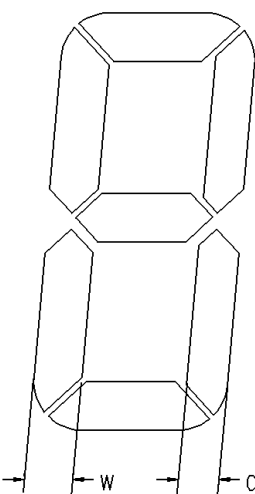
Items	Content	Criteria			
Transformation of segment		Not counted	Max. 2 defects allowed	Max.3 defects allowed	
		$x < 0.1\text{mm}$	$0.1\text{mm} \leq x \leq 0.2\text{mm}$		
		$x = (a+b)/2$			
		Not counted	Max. 1 defects allowed		
		$a < 0.1\text{mm}$	$0.1\text{mm} \leq a \leq 0.2\text{mm}$ $D > 0$		
		Max.2 defects allowed $0.8W \leq a \leq 1.2W$  $a = \text{measured value of width}$ $W = \text{nominal value of width}$			