



MULTI-INNO TECHNOLOGY CO., LTD.

LCD MODULE SPECIFICATION

Model : MI320240N-G-1

Revision	2.0
Engineering	
Date	
Our Reference	



Date	Rev.No.	Revision Items	Prepared	Checked	Approved
2007.6.7	V1.0	First Release			
2008.10.8	V2.0	Change IC			



CONTENTS

	Page
1. General Specifications -----	3
2. Outline Drawing -----	4
3. Circuit Block Diagram -----	5
4. Absolute Maximum Ratings -----	7
5. Electrical Specifications and Instruction Code -----	8
6. Optical Characteristics -----	13
7. Reliability -----	16
8. Quality level-----	17
9. Precautions for Use of LCD Modules -----	21

1.General Specifications

Item	Contents	Unit	Note
LCD Type	FSTN	-	
Display color	-		1
LCD Duty	1/240	-	
LCD Bias	1/16	-	
Viewing Direction	9:00	O'Clock	
Viewing Area(W×H)	79.8×60.6	mm	
Active Area(W×H)	76.785×57.585	mm	
Number of Dots	320×240	mm	
Dote Size(W×H)	0.225×0.225	mm	
Dot Pitch(W×H)	0.24×0.24	mm	
Controller	NT7701 & NT7709 or the equivalent	-	
V _{DD}	3.0-5.0	V	
V _{op}	22.5	V	
Outline Dimensions	Refer to outline drawing on next page		
Backlight	white	-	
Operating Temperature	-20~+70°C	-	
Storage Temperature	-30~+80°C	-	
Weight	TBD	g	2
Data Transfer	4 bits parallel	-	
Polarizer Mode	Transflective/Positive	-	

Note 1: Color tune is slightly changed by temperature and driving voltage.

Note 2: TBD- To Be Determined.

Note 3: Requirements on Environmental Protection:RoHS

2. Outline Drawing

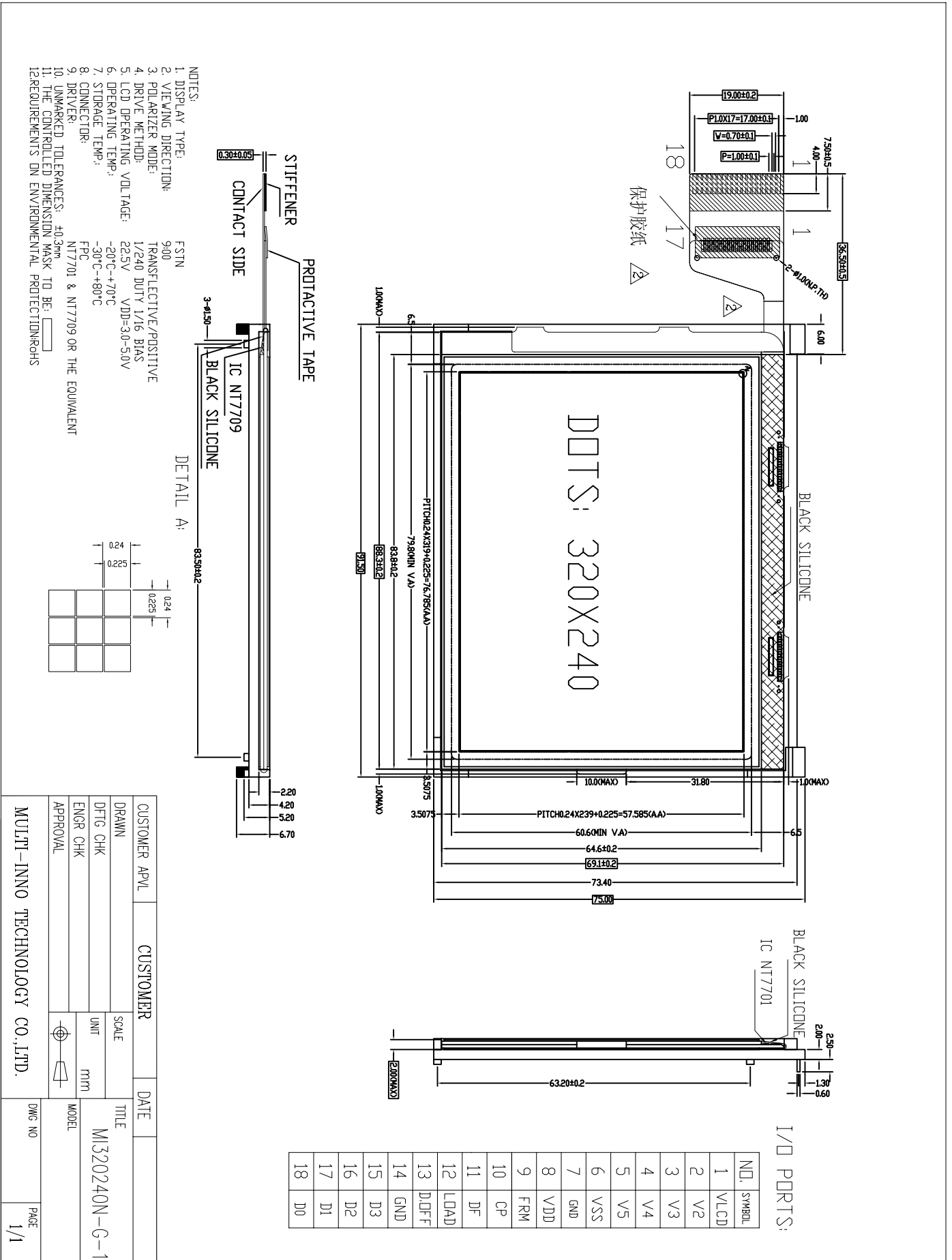

3. Circuit Block Diagram

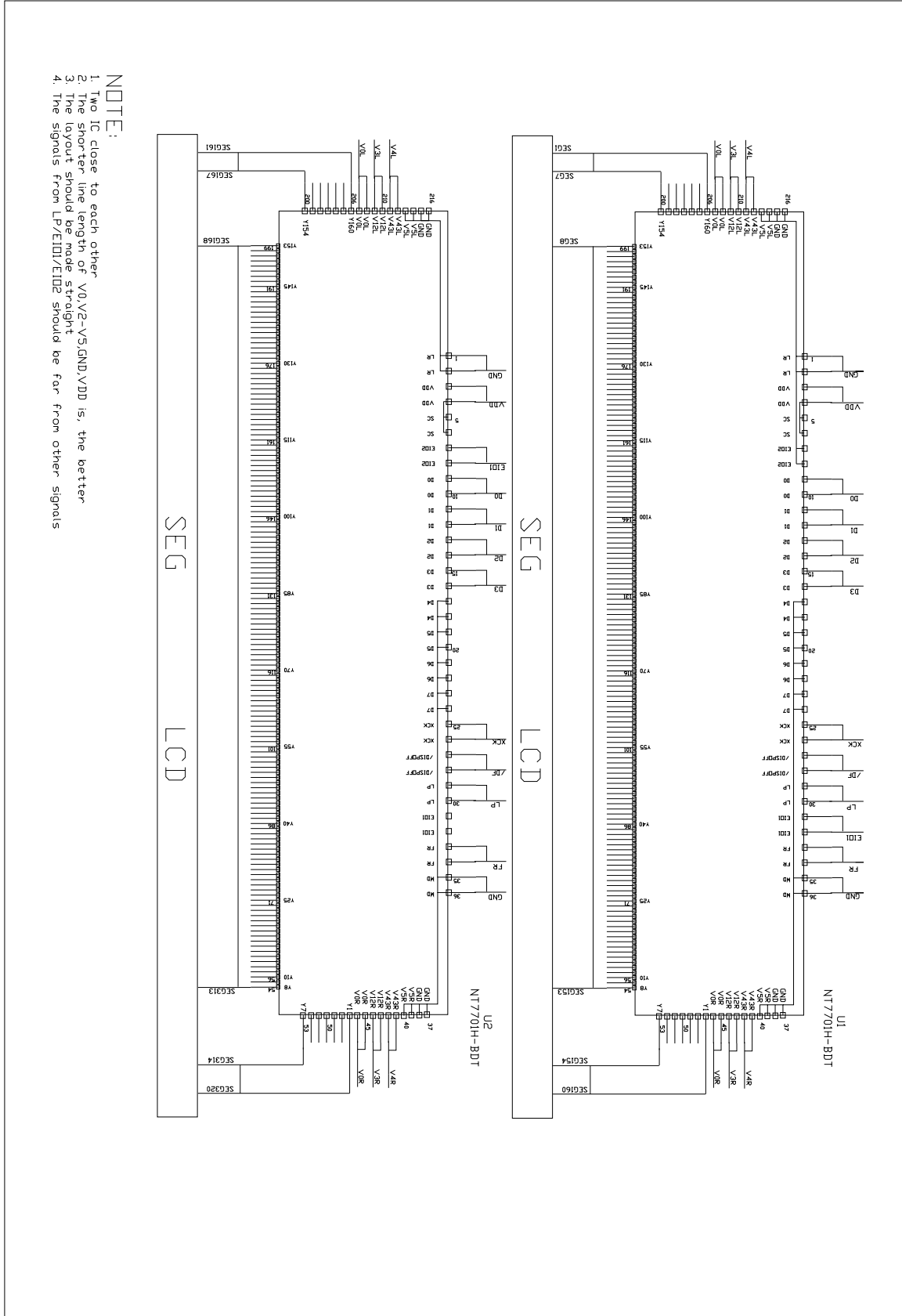

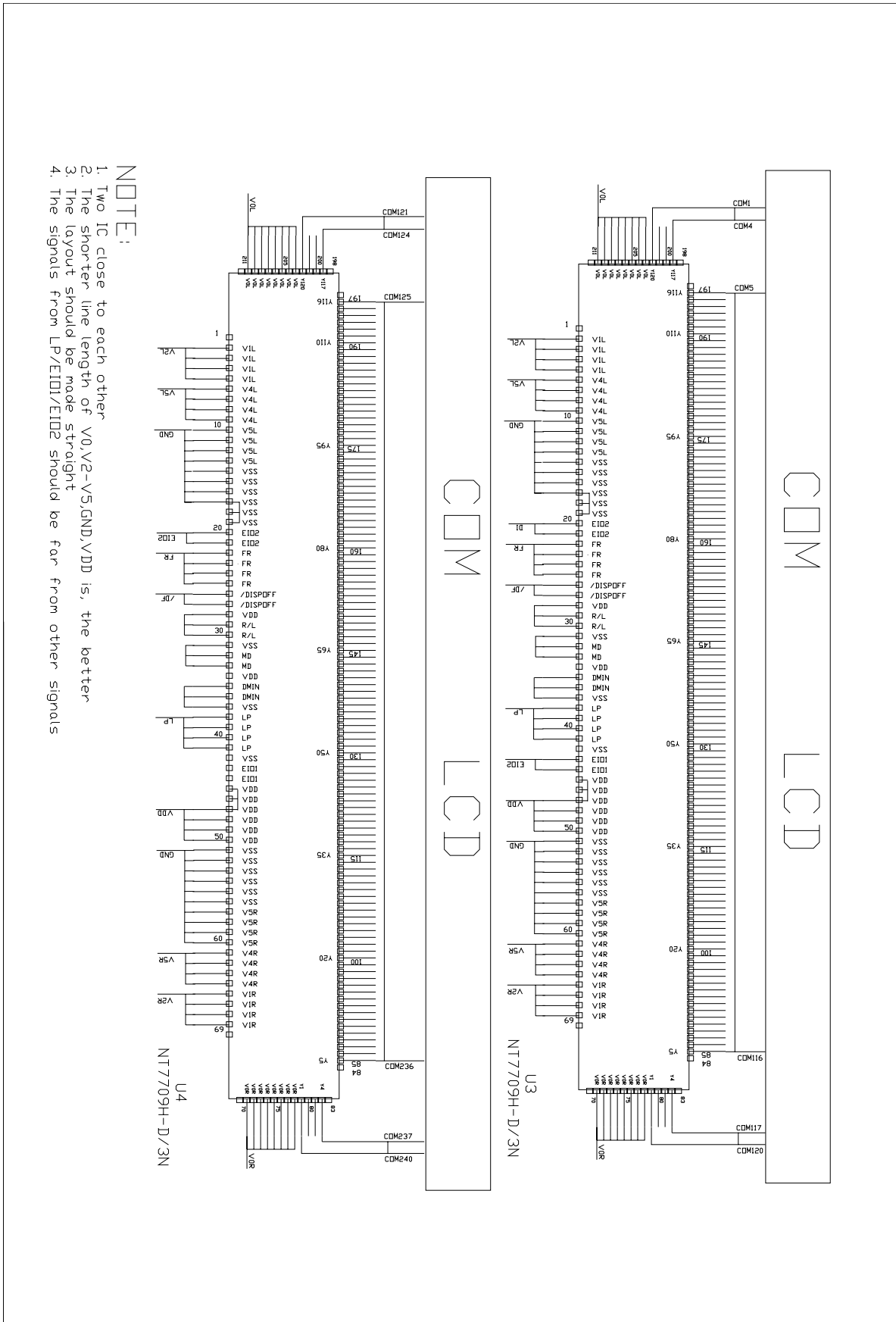

NOTE:

1. Two IC close to each other
2. The shorter line length of V0,V2-V5,GND,VDD is, the better
3. The layout should be made straight
4. The signals from LP/EIO1/EIO2 should be far from other signals

4. Absolute Maximum Ratings(Ta=25°C)

Item	Symbol	Min.	Max.	Unit	Note
Power Supply Voltage	V _{DD}	-0.3	7.0	V	
Power Supply Voltage for LCD	V _{op}	-0.3	30	V	
Logic Signal Input Voltage	V _I	-0.3	V _{DD} +0.3	V	
Operating Temperature	Top	-20	+70	°C	
Storage Temperature	Tst	-30	+80	°C	

Notes:

1. If the module is above these absolute maximum ratings. It may become permanently damaged. Using the module within the following electrical characteristic conditions are also exceeded, the module will malfunction and cause poor reliability.
2. V_{DD} > V_{SS} must be maintained.

5. Electrical Specifications and Instruction Code

5.1 Electrical characteristics (Ta=25°C)

Parameter	Symbol	Condition	Min	Typ	Max	Unit	Note
Logic power voltage	V _{DD}	Ta=25°C	-	3	-	V	1
Input voltage	'H'	V _{IH}	V _{DD} =3.0V	0.8V _{DD}	-	V _{DD}	V
	'L'	V _{IL}	V _{DD} =3.0V	V _{SS}	-	0.2V _{DD}	V
Output Voltage	'H'	V _{OH}	-	0.8V _{DD}	-	V _{DD}	V
	'L'	V _{OL}	-	V _{SS}	-	0.2V _{DD}	V

Note:

1: IC default setting, Duty:1/240

5.1.1 LED backlight characteristics

Ta=25°C

Item	Symbol	Condition	MIN.	TYP.	MAX.	Unit
Forward voltage	V _f	I _f =75mA	--	4.0	4.2	V
Forward current	I _f	V _f = 4.0V	--	75	100	mA
Reverse voltage	V _r	--	--	--	10	V
Reverse Current	I _r	--	--	45	60	uA
Luminous intensity*	Bp	I _f =75mA	250	--	--	cd/m ²
Luminous Uniformity*	△Bp		75	--	--	%
Color coordinate*	X		0.283	--	0.330	--
	Y		0.276	--	0.339	--

Note:

- Measured at the bare LED backlight unit.
- If the backlight is above these maximum ratings for long time, the service life of the LED backlight will reduce or it will cause poor reliability.

5.2 Interface Signals

Pin No.	Symbol	Level	Description
1	VLCD	--	Bias power supply pins for LCD drive voltage. Ensure that the voltages are set such that: $VLCD > V2 > V3 > V4 > V5 > VSS$
2	V2	-	
3	V3	-	
4	V4	-	
5	V5	-	
6	VSS	0V	Ground pin
7	GND	0V	Ground pin
8	VDD	3V	Logic system power supply pin
9	FRM	H/L	Input/output pins for chip selection
10	CP	H/L	Clock input pin for taking display data
11	DF	H/L	AC signal input pin for LCD drive waveform
12	LOAD	H/L	Latch pulse input pin for display data
13	D.OFF	H/L	Control input pin for output of non-select level
14	GND	0V	Ground pin
15	D3	H/L	Data bit3
16	D2	H/L	Data bit2
17	D1	H/L	Data bit1
18	D0	H/L	Data bit0

5.3 Interface Timing Chart

AC Characteristics

Segment Mode (NT7701, $V_{SS} = V_5 = 0V$, $V_{DD} = 2.5 - 4.5V$, $V_0 = 15$ to 30 , and $T_A = -20$ to $+70^\circ C$, unless otherwise noted)

Parameter	Symbol	Min.	Typ.	Max.	Unit	Condition
Shift clock period	t_{WCK}	125	-		ns	$t_r, t_f \leq 11ns$, Note 1
Shift clock "H" pulse width	t_{WCKH}	51	-		ns	
Shift clock "L" pulse width	t_{WCKL}	51	-		ns	
Data setup time	t_{DS}	30	-		ns	
Data hold time	t_{DH}	40	-		ns	
Latch pulse "H" pulse width	t_{WLPH}	51	-		ns	
Shift clock rise to Latch pulse rise time	t_{LD}	0	-		ns	
Shift clock fall to Latch pulse fall time	t_{SL}	51	-		ns	
Latch pulse rise to Shift clock rise time	t_{LS}	51	-		ns	
Latch pulse fall to Shift clock fall time	t_{LH}	51	-		ns	
Input signal rise time	t_r		-	50	ns	Note 2
Input signal fall time	t_f		-	50	ns	Note 2
Enable setup time	t_S	36	-		ns	
$\overline{DISPOFF}$ Removal time	t_{SD}	100	-		ns	
$\overline{DISPOFF}$ enable pulse width	t_{WDL}	1.2	-		μs	
Output delay time (1)	t_D		-	78	ns	$CL = 15pF$
Output delay time (2)	t_{pd1}, t_{pd2}		-	1.2	μs	$CL = 15pF$
Output delay time (3)	t_{pd3}		-	1.2	μs	$CL = 15pF$

Note

1. Take the cascade connection into consideration.
2. $(t_{CK} - t_{WCKH} - t_{WCKL})/2$ is the maximum in the case of high speed operation.

6. Optical Characteristics

Item		Symbol	Condition	Min.	Typ.	Max.	Unit
Viewing Angle	θ_x	$C_r \geq 2$	$\theta_y = 0^\circ$	-20	--	30	Deg
	θ_y		$\theta_x = 0^\circ$	-30	--	30	
Contrast Ratio		C_r	$\theta_x = 0^\circ$ $\theta_y = 0^\circ$	3.0		3.2	
Response Time	Turn on	T_{on}	$\theta_x = 0^\circ$ $\theta_y = 0^\circ$	-	-	350	ms
	Turn off	T_{off}		-	-	350	

Note 1: The data are measured after LEDs are turned on for 5 minutes. LCM displays full white. The brightness is the average value of 9 measured spots. Measurement equipment PR-705 ($\Phi 10\text{mm}$)

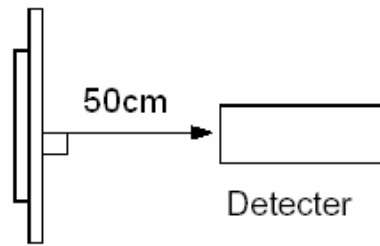

Note 2: $\Delta Bp = Bp (\text{Min.}) / Bp (\text{Max.}) \times 100 (\%)$

$Bp (\text{Max.})$ = Maximum brightness in 9 measured spots

$Bp (\text{Min.})$ = Minimum brightness in 9 measured spots.

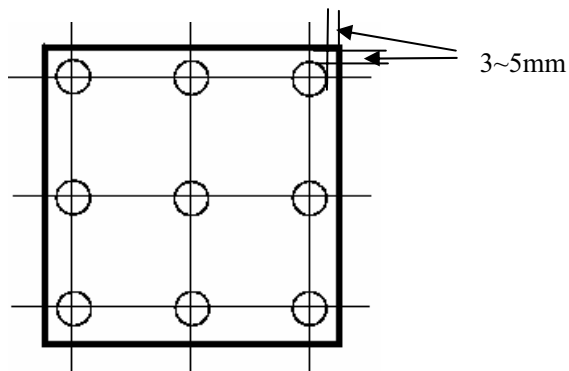

Measurement equipment PR-705 ($\Phi 10\text{mm}$)

Note 3: Definition of Viewing Angle (Test LCD using DMS501)

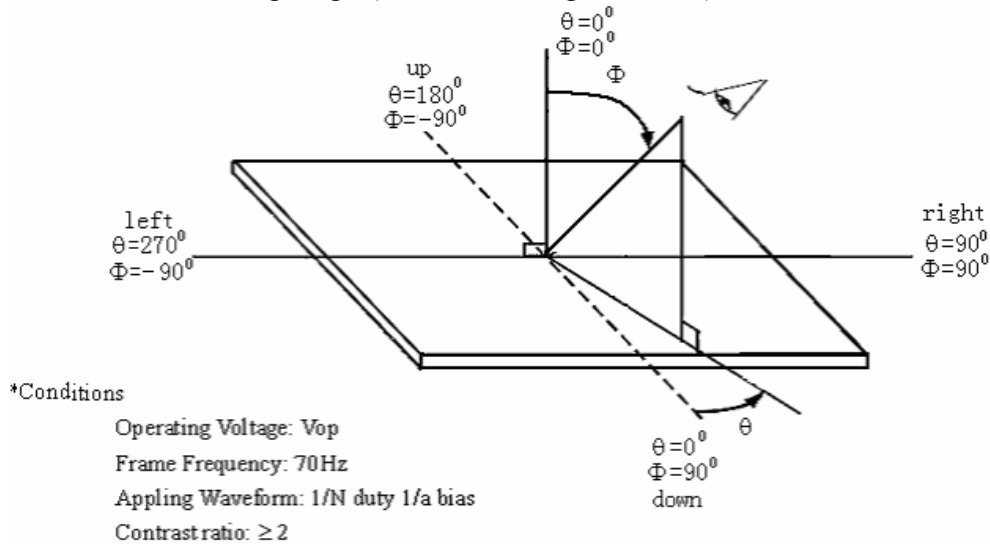

Note 4: Definition of contrast ratio. (Test LCD using DMS501)

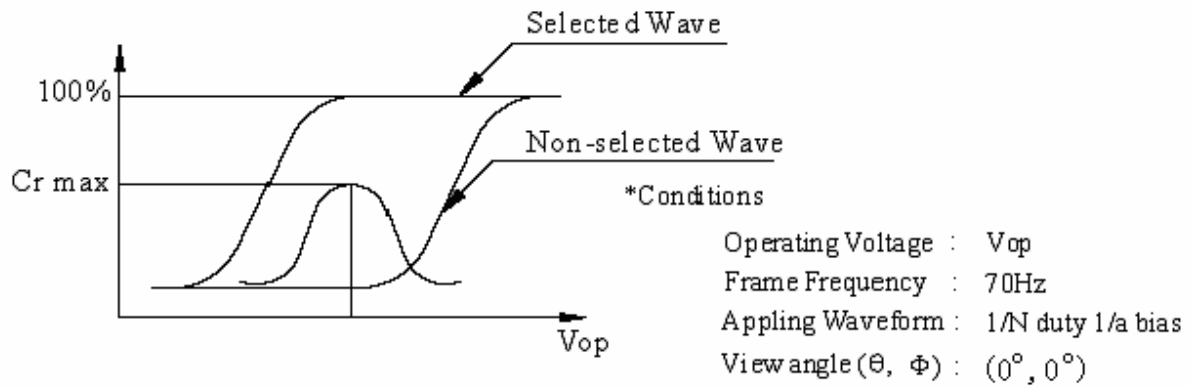

$$\text{Contrast ratio}(Cr) = \frac{\text{Brightness of selected dots}}{\text{Brightness of non-selected dots}}$$

Note 5: Definition of Response time(Test LCD using DMS501)

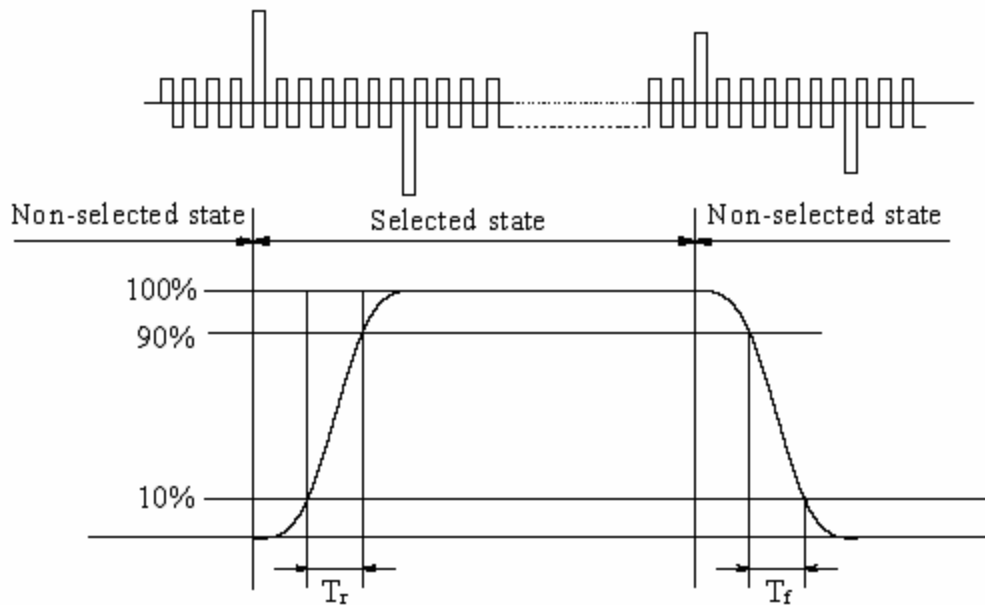

Note 6: Definition of Color of CIE Coordinate and NTSC Ratio.

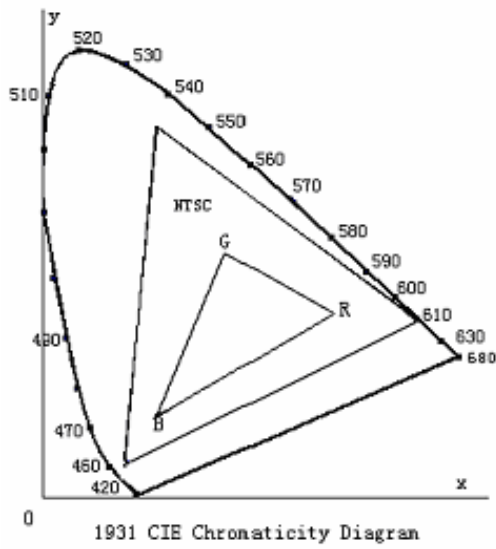

Color gamut:

$$S = \frac{\text{area of } RGB \text{ triangle}}{\text{area of } NTSC \text{ triangle}} \times 100\%$$

7. Reliability

No.	Test Item	Test condition	Criterion
1	High Temperature Storage	80°C±2°C 96H Restore 4H at 25°C	1. After testing, cosmetic defects should not happen. 2. Total current consumption should not be over 10% of initial value.
2	Low Temperature Storage	-30°C±2°C 96H Restore 4H at 25°C	
3	High Temperature Operation	70°C±2°C 48H Restore 4H at 25°C	
4	Low Temperature Operation	-20°C±2°C 48H Restore 4H at 25°C	
5	High Temperature /Humidity Storage	40°C±2°C 90%RH 48H	
6	Temperature Cycle	-30°C ←→ 25°C ←→ 80°C 5min 30min ←→ 25°C , 5min after 10cycle, Restore 4H at 25°C	
7	Vibration Test (package state)	10Hz~150Hz, 100m/s ² , 120min	Not allowed cosmetic and electrical defects.
8	Shock Test (package state)	Half- sine wave, 300m/s ² , 18ms	
9	Atmospheric Pressure Test	25kPa 16H Restore 2H	

8 Quality level

8.1 Notes for quality standard

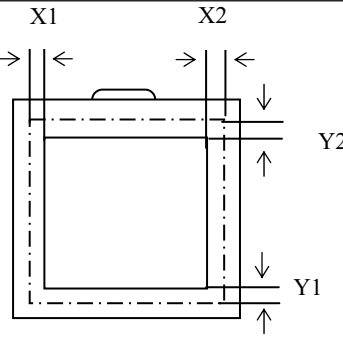
	Note		
General	1. Should any defects which are not specified in this standard happen, additional standard shall be determined by mutual agreement between customer and Multi-inno. 2. Viewing Area should be the area which Multi-inno guarantees. 3. Limited sample should be prior to this Inspection standard. 4. Viewing Judgement should be under static pattern. 5. Inspection conditions Inspection distance : 250 mm (from the sample) Temperature : 25±5℃ Inspection angle : 45degrees in LCD view direction		
Definitions of Inspection items	Pinhole, Bright spot, Black spot, White spot, Black line, White Line, Foreign particle, Bubble	The color of a small area is different from the remainder. The phenomenon dose not change with voltage.	
	Contrast variation	The color of a small area is different from the remainder. The phenomenon changes with voltage.	
	Polarizer defect	Scratch, Dirt, Particle, Bubble on polarizer or between polarizer and glass.	
	Glass defect	Glass crack, Shaved corner of glass, Surplus glass	
Definitions of Inspection ranges	 <p style="text-align: center;">Dividing A zone and B zone proceed to make a judgment.</p> <p>A zone : Inside Viewing area B zone : Outside Viewing area X1(A.A~V.A): mm X2(A.A~V.A): mm Y1(A.A~V.A): mm Y2(A.A~V.A): mm</p>		
Outgoing Inspection standard	Inspection level II Normal Inspection Sampling standard conforms to GB2828		
	Rank	Inspection Item	AQL(Number of defective LCMs counted)
	Major defect	All Functional defects(Such as No display, Display abnormally, Open or missing segment, Short circuit, Missing component, No sound, Blight abnormally),Outline dimension beyond the drawing	0.65
Minor defect	Appearance defects, such as Black/White spot, Bright spot, Pinhole, Black/White line, Contrast variation, Bubble Glass defect, Polarizer defect, and so on. Details of the standard as follows.	1.50	

8.2 Standards of inspection items

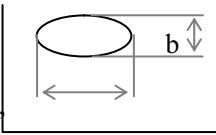
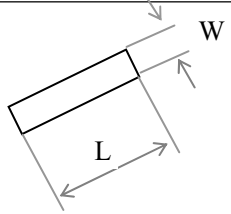
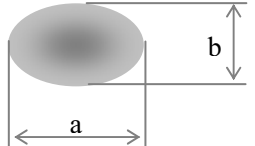
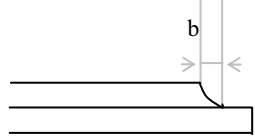
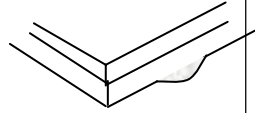
Inspection item	Judgement standard			
	Category		Acceptable number	
			A zone	B zone
1 Black spot, White spot Bright Spot, Pinhole Foreign Particle, Bubble and Particle Between polarizer and glass, Scratch on polarizer 	A	$\Phi \leq 0.15$	Neglecte	Neglected
	B	$0.15 < \Phi \leq 0.20$		
	C	$0.20 < \Phi \leq 0.30$	1	
	D	$0.30 < \Phi$	0	
	Total defective point(B,C)		3	
2 Black line, White line, Bubble and Particle Between Polarizer and glass, Scratch on polarizer  W: Width, L: Length(mm)	A	$W \leq 0.10$	Neglected	Neglected
	B	$0.01 < W \leq 0.03 \quad L \leq 3.0$	2	
	C	$0.03 < W \leq 0.05 \quad L \leq 3.0$	1	
	D	$0.05 < W$	0	
	Total defective point(B,C)		2	
3 Contrast variation  $\Phi=(a+b)/2(\text{mm})$	A	$\Phi \leq 0.2$	Neglected	Neglected
	B	$0.2 < \Phi \leq 0.3$	2	
	C	$0.3 < \Phi \leq 0.4$	1	
	D	$0.4 < \Phi$	0	
	Total defective point(B,C)		3	
4	Bubble inside cell	any size	none	none
5 Polarizer defect (if Polarizer is used) Scratch and damage on polarizer, Particle on polarizer or between polarizer and glass. Bubble, dent and convex	Refer to item 1 and item 2.			
	A	$\Phi \leq 0.3$	Neglected	Neglected
	B	$0.3 < \Phi \leq 0.7$	2	
	C	$0.7 < \Phi$	0	
Total defective point(B,C)		2		
6 Surplus glass  ①Stage surplus glass  ②Surrounding surplus glass	$b \leq 0.3\text{mm}$			
	Should not influence outline dimension and assembling.			

Inspection item		Judgment standard									
		Category(application: B zone)									
7	Glass defect crack	①The front of lead terminals	<table border="1"> <tr> <td>A</td> <td>If $a \leq t$ and $b \leq 1.0$, c is not limited</td> </tr> <tr> <td>B</td> <td>$a \leq t$, $1 \leq b \leq 2\text{mm}$, $c \leq 3\text{mm}$</td> </tr> <tr> <td>C</td> <td>If glass crack cover alignment mark, $b \leq 0.5\text{mm}$.</td> </tr> <tr> <td>D</td> <td>Crack at two sides of lead terminals should not cover patterns and alignment mark</td> </tr> </table>	A	If $a \leq t$ and $b \leq 1.0$, c is not limited	B	$a \leq t$, $1 \leq b \leq 2\text{mm}$, $c \leq 3\text{mm}$	C	If glass crack cover alignment mark, $b \leq 0.5\text{mm}$.	D	Crack at two sides of lead terminals should not cover patterns and alignment mark
		A	If $a \leq t$ and $b \leq 1.0$, c is not limited								
		B	$a \leq t$, $1 \leq b \leq 2\text{mm}$, $c \leq 3\text{mm}$								
		C	If glass crack cover alignment mark, $b \leq 0.5\text{mm}$.								
D	Crack at two sides of lead terminals should not cover patterns and alignment mark										
②Surrounding crack—non-contact side seal	$b < \text{Inner border line of the seal}$										
③ Surrounding crack— contact side	$b < \text{Outer border line of the seal}$										
④Corner	<table border="1"> <tr> <td>A</td> <td>$a \leq t$, $b \leq 3.0$, $c \leq 3.0$</td> </tr> </table> <p>*Glass crack should not cover patterns used for</p>	A	$a \leq t$, $b \leq 3.0$, $c \leq 3.0$								
A	$a \leq t$, $b \leq 3.0$, $c \leq 3.0$										

Inspection item		Judgement standard	
8	PCB defect	<p>Component soldering: No cold soldering, short, open circuit, burr, tin ball The flat encapsulation component position deviation must be less than 1/2 width of the pin (Pic.1); the sheet component deviation: Pin deviates from the pad and contact with the near components is not permitted (Pic.2)</p>	<p>Component</p> <p>Soldering pad Lead Component</p> <p>$L \leq W/2$ W</p> <p>$L1 > 0$ $L2 > 0$</p>
		<p>lead defect: The lead lack must be less than 1/2 of its width; The lead burr must be less than 1/2 of the seam; Impurities connect with the near leads is not permitted</p>	
		<p>Connector soldering: Soldering tin is at contact position of the plug and socket is not permitted No foundation is scald Serious cave distortion on plug and socket contact pin is not permitted</p>	<p>head Base Board</p> <p>Soldering tin is not permit in this area</p> <p>Soldering tin is not permit in this area</p> <p>socket Base Board</p>

9. Precautions for Use of LCD Modules

9.1 Handling Precautions

9.1.1 The display panel is made of glass. Do not subject it to a mechanical shock by dropping it from a high place, etc.

9.1.2 If the display panel is damaged and the liquid crystal substance inside it leaks out, be sure not to get any in your mouth, if the substance comes into contact with your skin or clothes, promptly wash it off using soap and water.

9.1.3 Do not apply excessive force to the display surface or the adjoining areas since this may cause the color tone to vary.

9.1.4 The polarizer covering the display surface of the LCD module is soft and easily scratched. Handle this polarizer carefully.

9.1.5 If the display surface is contaminated, breathe on the surface and gently wipe it with a soft dry cloth. If still not completely clear, moisten cloth with one of the following solvents:

— Isopropyl alcohol

— Ethyl alcohol

Solvents other than those mentioned above may damage the polarizer. Especially, do not use the following:

— Water

— Ketone

— Aromatic solvents

9.1.6 Do not attempt to disassemble the LCD Module.

9.1.7 If the logic circuit power is off, do not apply the input signals.

9.1.8 To prevent destruction of the elements by static electricity, be careful to maintain an optimum work environment.

a. Be sure to ground the body when handling the LCD Modules.

b. Tools required for assembly, such as soldering irons, must be properly ground.

c. To reduce the amount of static electricity generated, do not conduct assembly and other work under dry conditions.

- d. The LCD Module is coated with a film to protect the display surface. Be care when peeling off this protective film since static electricity may be generated.

9.2 Storage precautions

9.2.1 When storing the LCD modules, avoid exposure to direct sunlight or to the light of fluorescent lamps.

9.2.2 The LCD modules should be stored under the storage temperature range. If the LCD modules will be stored for a long time, the recommend condition is:

Temperature : $0^{\circ}\text{C} \sim 40^{\circ}\text{C}$

Relatively humidity: $\leq 80\%$

9.2.3 The LCD modules should be stored in the room without acid, alkali and harmful gas.

9.3 The LCD modules should be no falling and violent shocking during transportation, and also should avoid excessive press, water, damp and sunshine.