



**MULTI-INNO TECHNOLOGY CO., LTD.**

[www.multi-inno.com](http://www.multi-inno.com)

## LCD MODULE SPECIFICATION

**Model : MI160128B-2**

**For Customer's Acceptance:**

Customer	
Approved	
Comment	

Revision	1.0
Engineering	
Date	2010-08-22
Our Reference	



**RECORDS OF REVISION**

Date	Rev.	Description	Note	Page
2010/8/22	1.0	Revised Contents		



## Contents

### 1. SPECIFICATIONS

- 1.1 Features
- 1.2 Mechanical Specifications
- 1.3 Absolute Maximum Ratings
- 1.4 DC Electrical Characteristics
- 1.5 Optical Characteristics
- 1.6 Backlight Characteristics

### 2. MODULE STRUCTURE

- 2.1 Counter Drawing
- 2.2 Interface Pin Description
- 2.3 Timing Characteristics
- 2.4 Display Command

### 3. QUALITY ASSURANCE SYSTEM

- 3.1 Quality Assurance Flow Chart
- 3.2 Inspection Specification

### 4. RELIABILITY TEST

- 4.1 Reliability Test Condition

### 5. PRECAUTION RELATING PRODUCT HANDLING

- 5.1 Safety
- 5.2 Handling
- 5.3 Storage
- 5.4 Terms of Warranty

Note : For detailed information please refer to IC data sheet : T6963



## 1. SPECIFICATIONS

### 1.1 Features

Item	Standard Value
Display Type	160 * 128 dots
LCD Type	STN, Gray, Transflective, Positive, Extended Temp.
Driver Condition	LCD Module 1/64 Duty , 1/ 9Bias
Viewing Direction	6 O'clock
Backlight	YG LED B/L
Weight	175g
Interface	—
ROHS	THIS PRODUCT CONFORMS THE ROHS OF PTC Detail information please refer web side : <a href="http://www.multi-inno.com">http://www.multi-inno.com</a>

### 1.2 Mechanical Specifications

Item	Standard Value	Unit
Outline Dimension	129.0(L) *104.5(W)*16.4 (H)max.	mm
Viewing Area	101.0(L) *82.0(W)	mm
Active Area	95.96(L) *76.76(W)	mm
Dot Size	0.56(L) *0.56(W)	mm
Dot Pitch	0.6(L)*0.6(W)	mm

Note : For detailed information please refer to LCM drawing

### 1.3 Absolute Maximum Ratings

Item	Symbol	Condition	Min.	Max.	Unit
Power Supply Voltage	V <sub>DD</sub>	-	-0.3	7.0	V
Input Voltage	V <sub>IN</sub>	-	-0.3	V <sub>DD</sub> +0.3	V
Operating Temperature	T <sub>OP</sub>	Excluded B/L	-20	70	°C
Storage Temperature	T <sub>ST</sub>	Excluded B/L	-30	80	°C
Storage Humidity	H <sub>D</sub>	T <sub>a</sub> < 40 °C	-	90	%RH

## 1.4 DC Electrical Characteristics

 $V_{DD} = 5.0\text{ V} \pm 10\%$  ,  $V_{SS} = 0\text{V}$  ,  $T_a = 25^\circ\text{C}$ 

Item	Symbol	Condition	Min.	Typ.	Max.	Unit
Logic Supply Voltage	$V_{DD}$	-	4.5	5	5.5	V
“H” Input Voltage	$V_{IH}$	-	$V_{DD}-2.2$	-	$V_{DD}$	V
“L” Input Voltage	$V_{IL}$	-	0	-	0.8	V
“H” Output Voltage	$V_{OH}$	-	$V_{DD}-0.3$	-	$V_{DD}$	V
“L” Output Voltage	$V_{OL}$	-	0	-	0.3	V
Supply Current	$I_{DD}$	$V_{DD}=5\text{V}$	-	7.5	10.0	mA
LCM Driver Voltage	$V_{OP}$	-20°C				V
		25°C *1	11.8	12.0	12.2	
		70°C				

NOTE \*1: The  $V_{op}$  test point is VDD-VLCD.

## 1.5 Optical Characteristics

 $\text{LCD Module } 1/64\text{Duty}$  ,  $1/9\text{Bias}$  ,  $V_{OP} = 12.0\text{V}$  ,  $T_a = 25^\circ\text{C}$ 

Item	Symbol	Conditions	Min.	Typ.	Max.	Reference
View Angle	$\theta$	$C \geq 2.0, \varnothing = 0^\circ$	$0^\circ$	-	$40^\circ$	Notes 1 & 2
Contrast Ratio	C	$\theta = 25^\circ, \varnothing = 0^\circ$	4	6	-	Note 3
Response Time(rise)	$t_r$	$\theta = 25^\circ, \varnothing = 0^\circ$	-	90ms	135ms	Note 4
Response Time(fall)	$t_f$	$\theta = 25^\circ, \varnothing = 0^\circ$	-	210 ms	315ms	Note 4

**Note 1: Definition of angles  $\theta$  and  $\varnothing$**

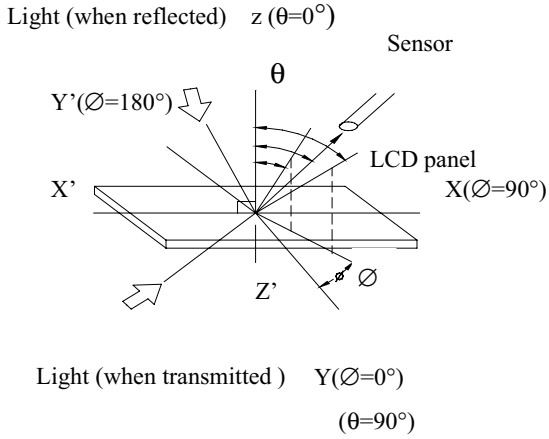

**Note 2: Definition of viewing angles  $\theta_1$  and  $\theta_2$**

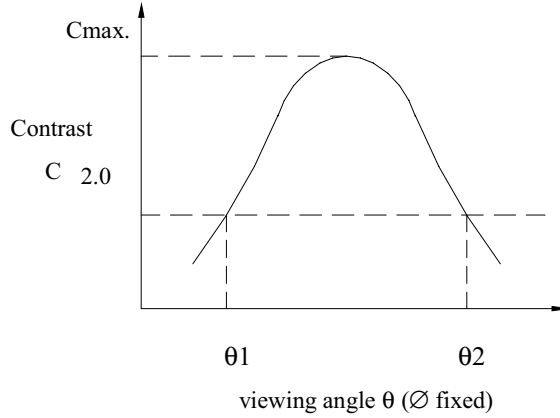

Note : Optimum viewing angle with the naked eye and viewing angle  $\theta$  at  $C_{max}$ . Above are not always the same

**Note 3: Definition of contrast C**

$$C = \frac{\text{Brightness (reflection) of unselected dot (B2)}}{\text{Brightness (reflection) of selected dot (B1)}}$$

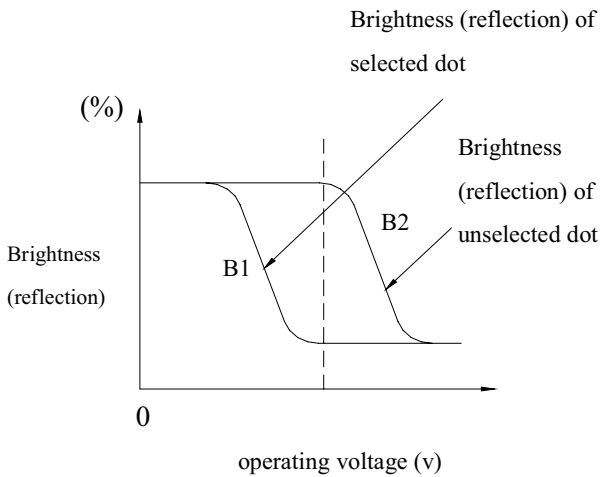

**Note 4: Definition of response time**

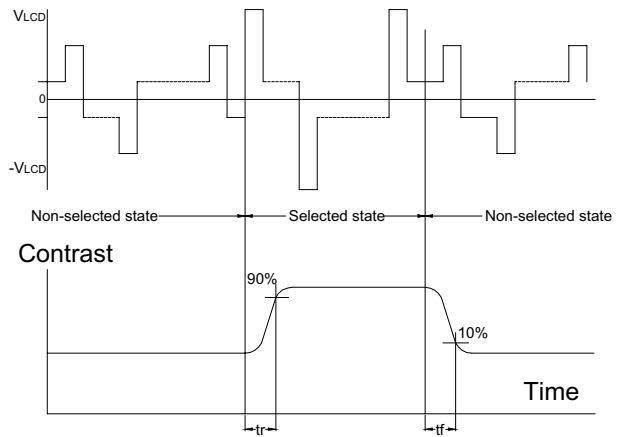

Note: Measured with a transmissive LCD panel which is displayed 1 cm<sup>2</sup>

$V_{LCD}$  : Operating voltage     $f_{FRM}$  : Frame frequency  
 $t_r$  : Response time (rise)     $t_f$  : Response time (fall)



## 1.6 Backlight Characteristics

LCD Module with LED Backlight

### Maximum Ratings

Item	Symbol	Conditions	Min.	Max.	Unit
Forward Current	IF	Ta =25°C	-	500	mA
Reverse Voltage	VR	Ta =25°C	-	8	V
Power Dissipation	PO	Ta =25°C	-	2.3	W
Operating Temperature	T <sub>OP</sub>	-	-20	70	°C
Storage Temperature	T <sub>ST</sub>	-	-30	80	°C
Solder Temp. for 3 Second	-	-	-	260	°C

### Electrical / Optical Characteristics

Ta =25°C

Item	Symbol	Conditions	Min.	Typ.	Max.	Unit
Forward Voltage	VF	IF= 200 mA	-	4.2	4.6	V
Reverse Current	IR	VR= 8 V	-	-	0.2	mA
Wavelength	λ p	IF= 200 mA	-	570	-	nm
Luminous Intensity (without LCD)	IV	IF= 200 mA	24	30	-	cd/m <sup>2</sup>
Color	Yellow-green					

## 2. MODULE STRUCTURE

### 2.1 Counter Drawing

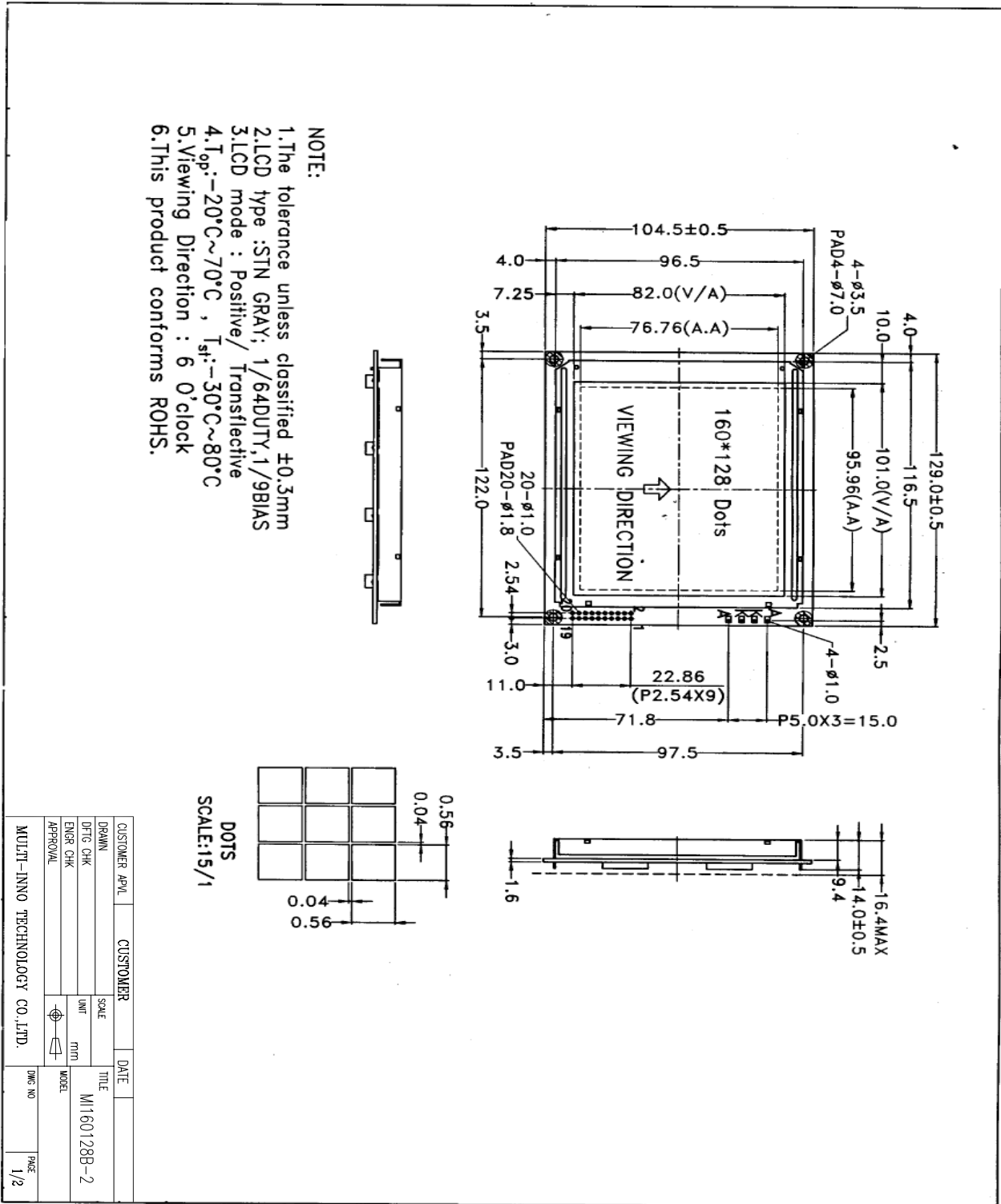





## 2.2 Interface Pin Description

Pin No.	Symbol	Function
1	FG	Frame ground
2	V <sub>SS</sub>	Power Supply (V <sub>SS</sub> =0)
3	V <sub>DD</sub>	Power Supply (V <sub>DD</sub> >V <sub>SS</sub> )
4	V <sub>L</sub> (V <sub>o</sub> )	Operating voltage for LCD
5	$\overline{\text{WR}}$	Data read (read data from the module at "L")
6	$\overline{\text{RD}}$	Data read (read data from the module at "L")
7	$\overline{\text{CE}}$	Chip enable for the module (active at "L")
8	C/ $\overline{\text{D}}$	$\overline{\text{WR}} = \text{"L"}; \text{C}/\overline{\text{D}} = \text{"H"} : \text{command write, C}/\overline{\text{D}} = \text{"L"} : \text{data write}$ $\overline{\text{WR}} = \text{"H"}; \text{C}/\overline{\text{D}} = \text{"H"} : \text{command read, C}/\overline{\text{D}} = \text{"L"} : \text{data read}$
9	N/C	No connection
10	$\overline{\text{RST}}$	Controller reset (module reset)
11~18	DB0~DB7	Data bus (D7=MSB, D0=LSB)
19	FS	Font select: already connected to V <sub>SS</sub> (8*8 dots font)
20	N/C	No connection

Contrast Adjust

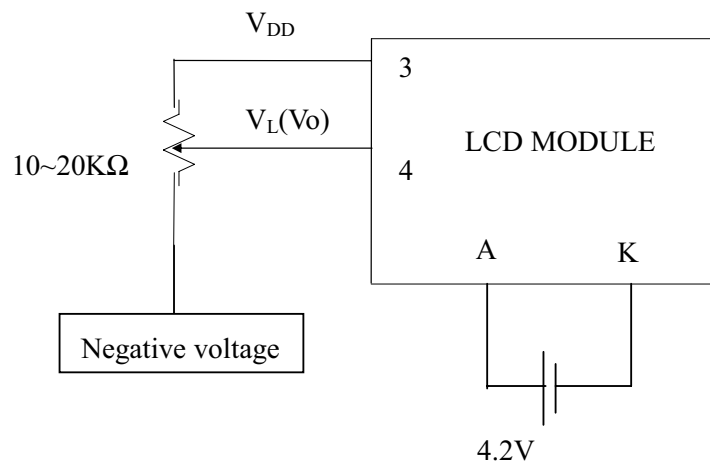

## 2.3 Timing Characteristics

### Bus Timing

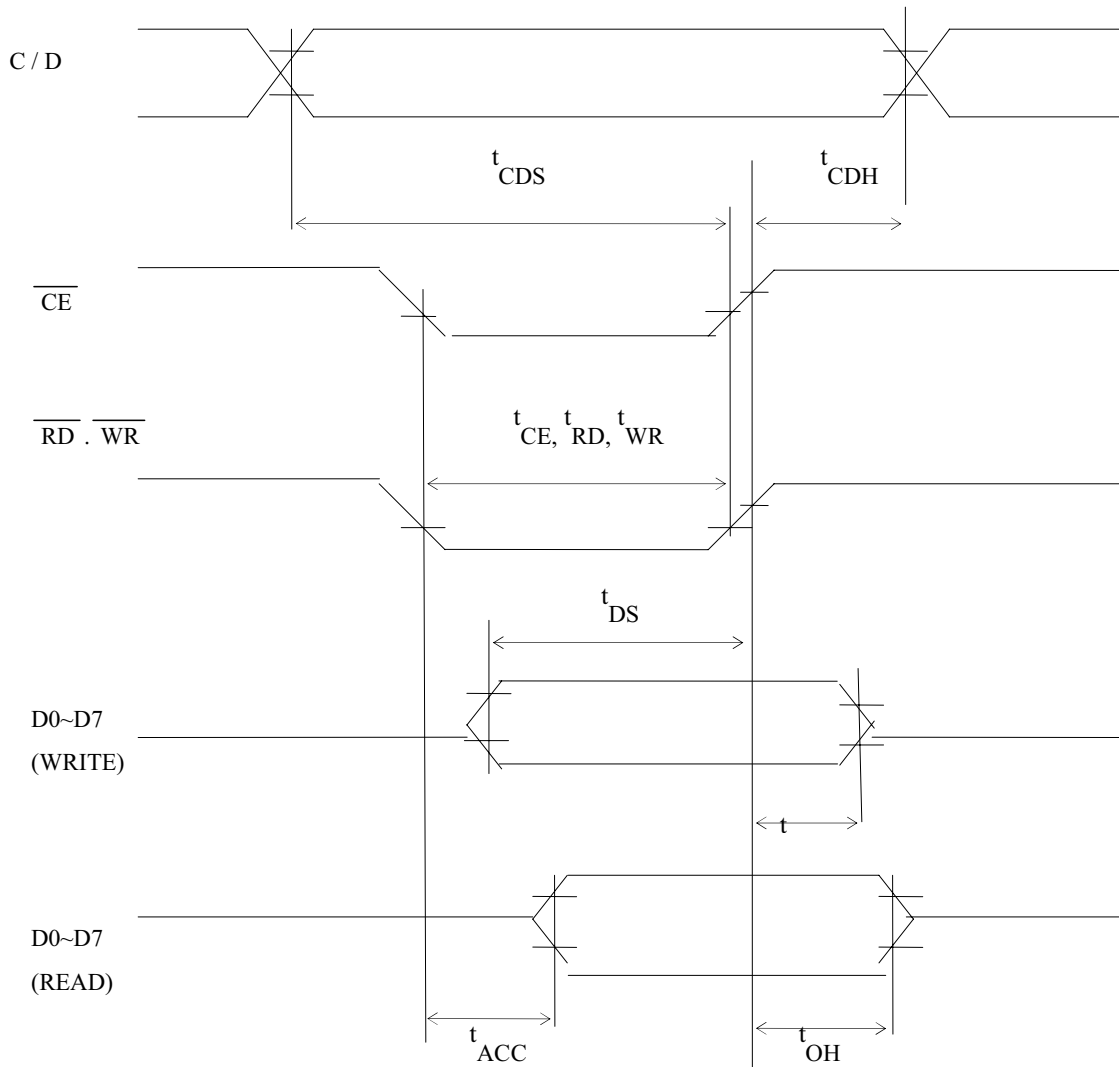

Unless otherwise noted,  $V_{DD}=5.0V\pm 10\%$ ,  $V_{SS}=0V$ ,  $T_a=25^\circ C$

ITEM	SYMBOL	TEST CONDITION	MIN.	MAX.	UNIT
C/D Set Up Time	$t_{CDS}$	-	100	-	ns
C/D Hold Time	$t_{CDH}$	-	10	-	ns
CE, RD, WR Pulse Width	$t_{CE}, t_{RD}, t_{WR}$	-	80	-	ns
Data Set Up Time	$t_{DS}$	-	80	-	ns
Data Hold Time	$t_{DH}$	-	40	-	ns
Access Time	$t_{ACC}$	-	-	150	ns
Output Hold Time	$t_{OH}$	-	10	50	ns

## 2.4 Display command

### 1.Register Set

Code	Hex.	Function	D1	D2
00100001	21H	Cursor pointer set	X ADRS	Y ADRS
00100010	22H	Offset register set	Data	00H
00100100	24H	Address pointer set	Low ADRS	High ADRS

#### (1) Cursor pointer set

The position of cursor is specified by X ADRS, Y ADRS. The cursor position is moved only by this command. The cursor pointer doesn't have the function of increment and decrement. The shift of cursor are set by this command. X ADRS, Y ADRS are specified following.

X ADRS                      00H~4FH (Lower 7bits are valid)

Y ADRS                      00H~1FH (Lower 5 bits are valid)

1. 1 screen drive

X ADRS 00~4FH

Y ADRS 00H~0FH

2. 2 screens drive

X ADRS 00~4FH

Y ADRS 00H~0FH  
Upper screen

Y ADRS 10H~1FH  
Lower screen

#### (2) Offset register set

The offset register is used to determine external character generator RAM area.

T693C has 16 bit address lines as follow.

MSB											LSB				
ad15	ad14	ad13	ad12	ad11	ad10	ad9	ad8	ad7	ad6	ad5	ad4	ad3	ad2	ad1	ad0

The upper 5 bit (ad15~ad11) are determined by offset register. The middle 8 bit (ad10~ad3) are determined by character code. The lower 3 bit (ad2~ad0) are determined by vertical counter.

The lower 5 bit of D1 (data) are valid.

The data format of external character generator RAM.



**(3)Address pointer set**

The address pointer set command is used to indicate the start address for writing (or reading) to external RAM.

The flow chart address pointer set command

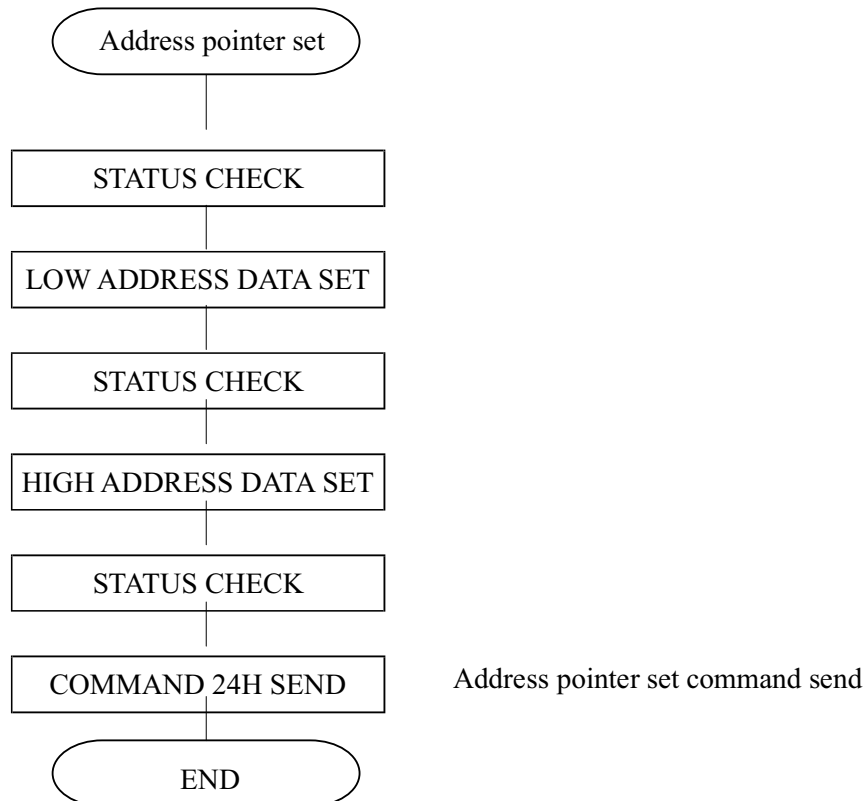

**2.Control word set**

Code	Hex.	Function	D1	D2
01000000	40H	Text home address set	Low address	High address
01000001	41H	Text area set	Columns	00H
01000010	42H	Graphic home address set	Low address	High address
01000011	43H	Graphic area set	Columns	00H

The home address and column size are defined by this command.

(1)Text home address set

The starting address of external display RAM for Text display is defined by this command. The text home address shows the left end and most upper position.

The relationship of external display RAM address and display position

TH		TH+CL
TH+TA		TH+TA+CL
(TH+TA)+TA		TH+2TA+CL
(TH+2TA)+TA		TH+3TA+CL
TH+(n-1)TA		TH+(n-1)TA+CL

TH : Text home address

TA : Text area number (columns)

CL : Columns are fixed by hardware. (pin-programmable)

(Example)

Text home address : 0000H  
 Text area : 0020H  
 MD2=H, MD3=H : 32 columns  
 DUAL=H, MDX=L, MD1=H : 4 lines

0000H	0001H		001EH	001FH
0020H	0021H		003EH	003FH
0040H	0041H		005EH	005FH
0060H	0061H		007EH	007FH

(2)Graphic home address set

The starting address of external display RAM for Graphic display is defined by this command. The Graphic home address show the left end most upper line.

The relationship of external display RAM address and display position

GH		GH+CL
GH+GA		GH+GA+CL
(GH+GA)+GA		GH+2GA+CL
(GH+2GA)+GA		GH+3GA+CL
GH+(n-1)GA		GH+(n-1)GA+CL

GH : Graphic home address

GA : Graphic area number (columns)

CL : Columns area fixed by hardware. (pin-programmable)



(Example)

Graphic home address : 0000H  
 Graphic area : 0020H  
 MD2=H, MD3=H : 32 columns  
 $\overline{\text{DUAL}} = \text{H}$ , MDS=L, MD0=H, MD1=H : 2 lines

0000H	0001H		001EH	001FH
0020H	0021H		003EH	003FH
0040H	0041H		005EH	005FH
0060H	0061H		007EH	007FH
0080H	0081H		009EH	009FH
00A0H	00A1H		00BEH	00BFH
00C0H	00C1H		00DEH	00DFH
00E0H	00E1H		00FEH	00FFH
0100H	0101H		011EH	011FH
0120H	0121H		013EH	013FH
0140H	0141H		015EH	015FH
0160H	0161H		017EH	017FH
0180H	0181H		019EH	019FH
01A0H	01A1H		01BEH	01BFH
01C0H	01C1H		01DEH	01DFH
01E0H	01E1H		01FEH	01FFH

(3)Text area set

The columns of display are defined by the hardware setting. This command can be used to adjust columns of display.

(Example)

LCD size : 20 columns, 4 lines  
 Text home address : 0000H  
 Text area : 0014H  
 MD2=H, MD3=H : 32 columns  
 DUAL=H, MDS=L, MD0=L, MD1=H : 4 lines

0000	0001	.....	0013	0014	.....	001F
0014	0015	.....	0027	0028	.....	0033
0028	0029	.....	003B	003C	.....	0047
003C	003D	.....	004F	0050	.....	005B







## (4)Graphic area set

The columns of display are defined by the hardware setting. This command can be used to adjust columns of graphic display.

## (Example)

LCD size : 20 columns, 2 lines  
 Text home address : 0000H  
 Text area : 0014H  
 MD2=H, MD3=H : 32 columns  
 DUAL=H, MDS=L, MDD=H, MD1=H : 2 lines

0000	0001	.....	0013	0014	.....	001F
0014	0015	.....	0027	0028	.....	0033
0028	0029	.....	003B	003C	.....	0047
003C	003D	.....	004F	0050	.....	005B
0050	0051	.....	0063	0064	.....	006F
0064	0065	.....	0077	0078	.....	0083
0078	0079	.....	008B	008C	.....	0097
008C	008D	.....	009F	00A0	.....	00AB
00A0	00A1	.....	00B3	00B4	.....	00BF
00B4	00B5	.....	00C7	00C8	.....	00D3
00C8	00C9	.....	00DB	00DC	.....	00E7
00DC	00DD	.....	00EF	00F0	.....	00FD
00F0	00F1	.....	0103	0104	.....	011F
0104	0105	.....	0127	0128	.....	0123
0128	0129	.....	013B	013C	.....	0147
013C	013D	.....	014F	0150	.....	0158

The address in graphic area can be continuous and RAM area can be used without ineffective area, if graphic area is defined the same number as the actual column number of LCD display.

### 3.Mode set

Code	Function	Operand
1000x000	“OR” Mode	-
1000x001	“EXOR” Mode	-
1000x011	“AND” Mode	-
1000x100	“TEXT ATTRIBUTE” Mode	-
10000xxx	Internal Character Generator Mode	-
10001xxx	External Character Generator Mode	-

The display mode is defined by this command. The display mode don't have changed until to send next this command.

Logically “OR”, “EXOR”, “AND” of text and graphic display can be displayed.

When internal character generator mode is selected, character code 00H~7FH are selected from built-in character generator ROM. The character code 80H~FFH are automatically selected external character generator RAM.

(Example)

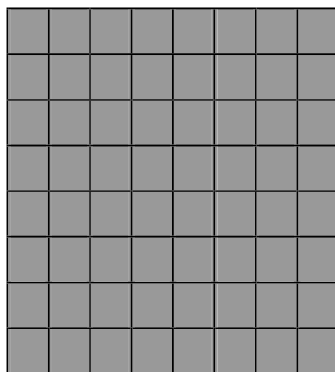

Graphic

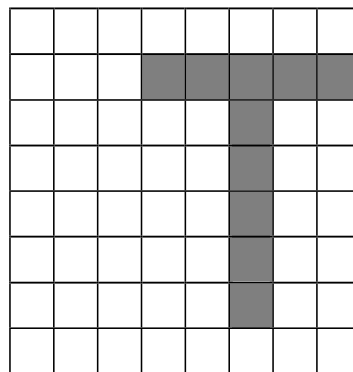

Text

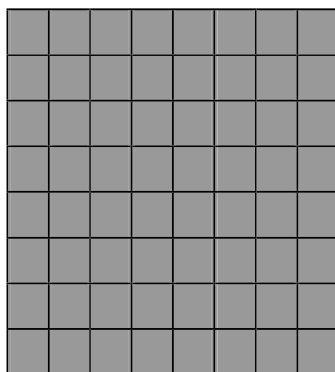

“OR”

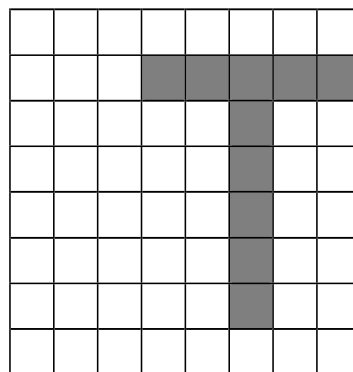

“AND”

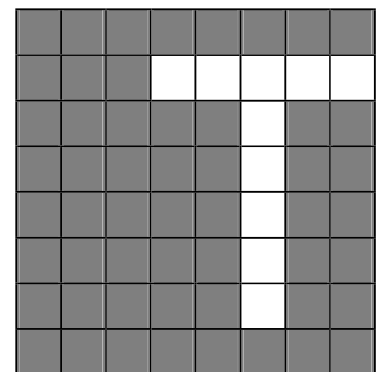

“EXOR”

Note: Only text display is attributed, because attribute data is located in graphic RAM area.

Attribute function

“Reverse display”, “Character blink” and “Inhibit” are called “Attribute”. The attribute data is written in the graphic area defined by Control word set command.

The mode set command selects text display only and graphic display cannot be displayed.

The attribute data of the 1st character in text area is written at the 1st 1byte in graphic area, and attribute data of n-th character is written at the n-th 1byte in graphic area. Attribute function is defined as follow.

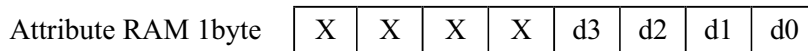

d3	d2	d1	d0	Function
0	0	0	0	Normal display
0	1	0	1	Reverse display
0	0	1	1	Inhibit display
1	0	0	0	Blink of normal display
1	1	0	1	Blink of reverse display
1	0	1	1	Blink of inhibit display

**4.Display mode**

Code	Function	Operand
10010000	Display off	-
1001xx10	Cursor on , blink off	-
1001xx11	Cursor on , blink on	-
100101xx	Text on, graphic off	-
100110xx	Text off, graphic on	-
100111xx	Text on , graphic on	-

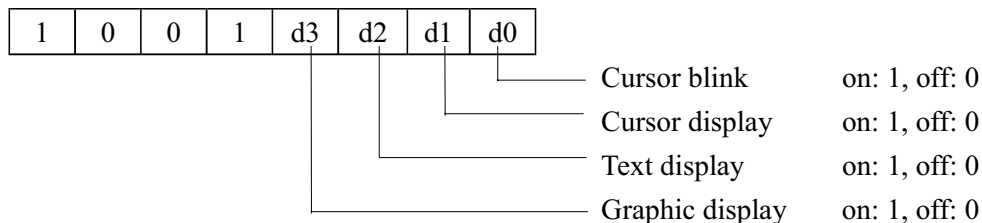

Note: It is necessary to turn on “Text display” and “Graphic display “ in following case.

- (1) Combination of text/graphic display
- (2) Attribute function

### 5. Cursor pattern select

Code	Function	Operand
10100000	1 line cursor	-
10100001	2 lines cursor	-
10100010	3 lines cursor	-
10100011	4 lines cursor	-
10100100	5 lines cursor	-
10100101	6 lines cursor	-
10100110	7 lines cursor	-
10100111	8 lines cursor	-

When cursor display is ON, this command selects the cursor pattern from 1 line to 8 lines. The cursor address is defined by cursor pointer set command.

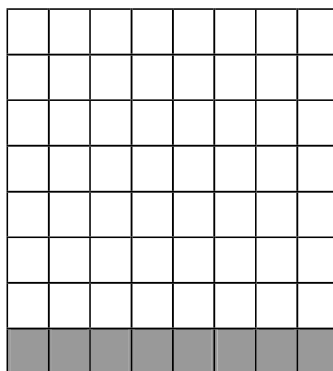

1 line cursor

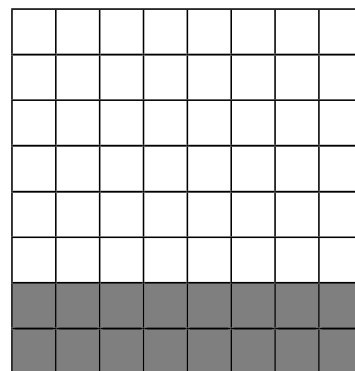

2 lines cursor

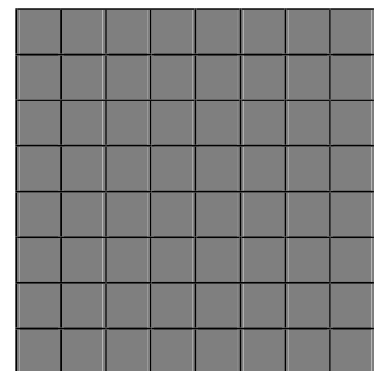

8 lines cursor

### 6. Data auto read/write

Code	Hex.	Function	Operand
10110000	B0H	Data auto write set	-
10110001	B1H	Data auto read set	-
10110010	B2H	Auto reset	-

This command is convenient to send full screen data from external display RAM.

After setting auto mode, “Data write (or read)” command is not necessary between each data.

“Data write (or read)” command should follow the “Address pointer set” and address pointer is automatically increment by + 1 after each data. After sending (or receiving) all data “Auto reset” is necessary to return normal operation because all data is regarded “Display data” and no command can be accepted in the auto mode.

Note : Status check for auto mode (STA2, STA should be checked between each data.

Auto reset should be performed after checking STA3=1 (STA2=1).

Please refer following flow chart.

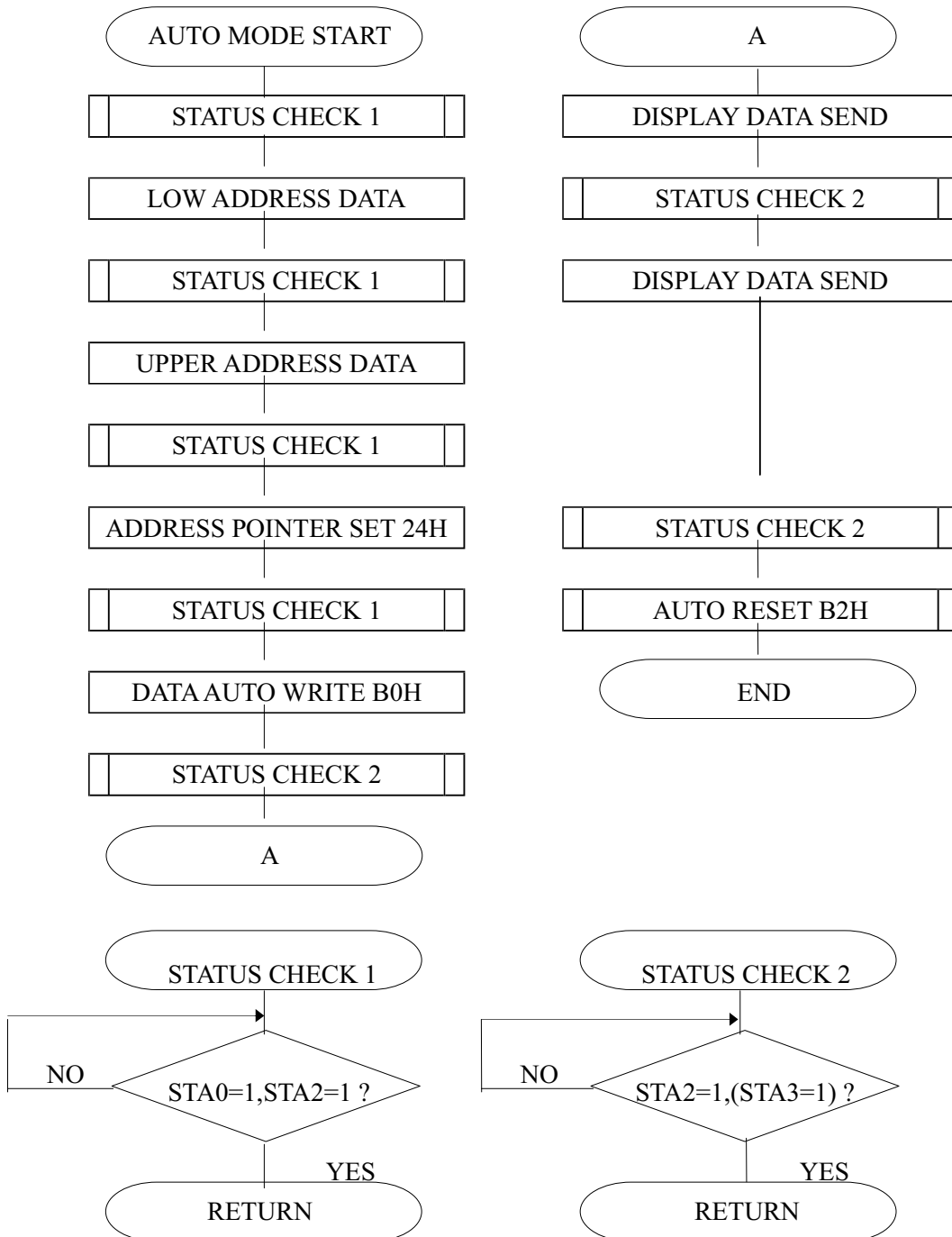

**7.Data read write**

Code	Hex.	Function	Operand
11000000	C0H	Data write and ADP increment	Data
11000001	C1H	Data read and ADP increment	-
11000010	C2H	Data write and ADP decrement	Data
11000011	C3H	Data read and ADP decrement	-
11000100	C4H	Data write and ADP nonvariable	Data
11000101	C5H	Data read and ADP nonvariable	-

This command is used for data write from MPU to external display RAM, and data read from external display RAM to MPU. Data write/data read should be executed after setting address by address pointer set command. Address pointer can be automatically increment or decrement by setting this command.

Note: This command is necessary for each 1 byte data.

Please refer following flow chart.

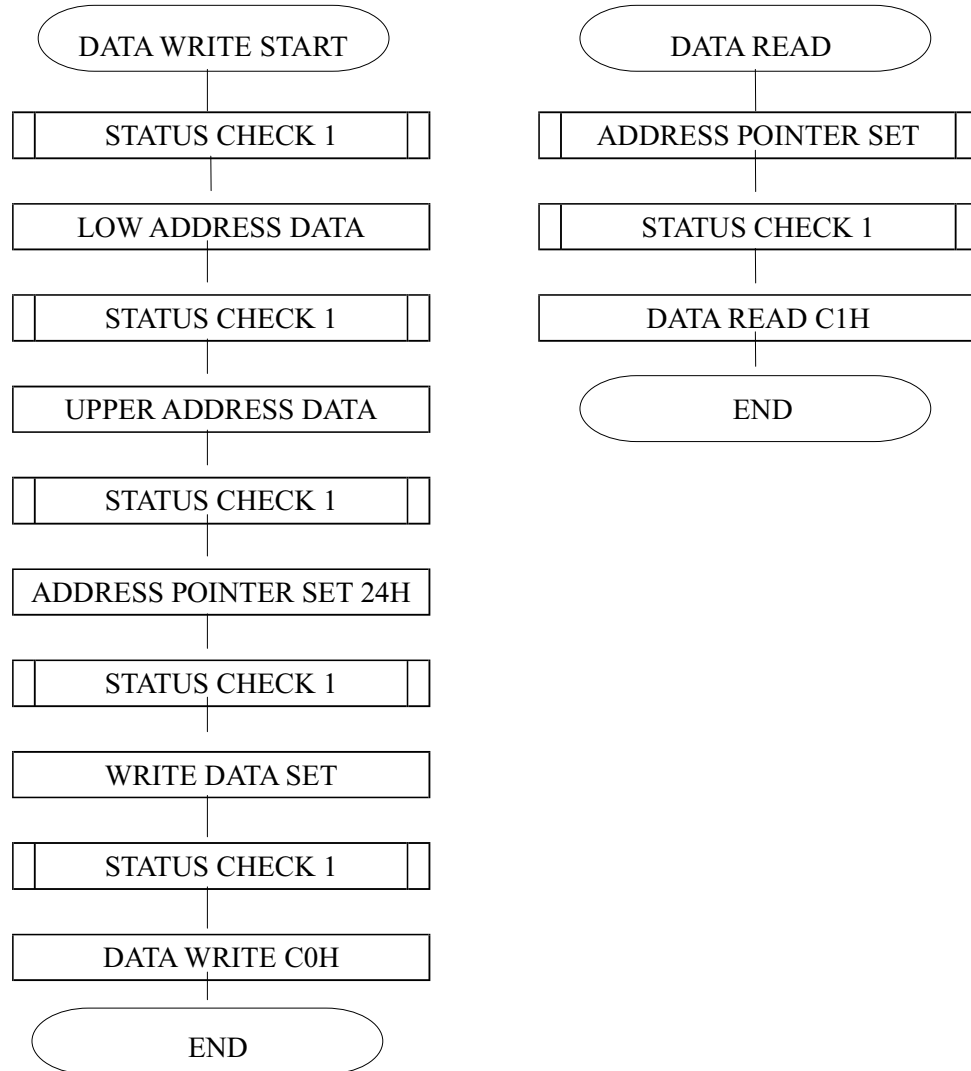

**8.Screen peek**

Code	Hex.	Function	Operand
11100000	E0H	screen peek	-

This command is used to transfer displayed 1 byte data to data stack, and this 1 byte data can be read from MPU by data access. The logical combination data of text and graphic display on LCD screen can be read by this command.

The status (STA6) should be checked just after “Screen peek” command. If the address determined by “Address pointer set” command is not in graphic area, this command ignored and status flag (STA6) is set.

Please refer following flow chart.

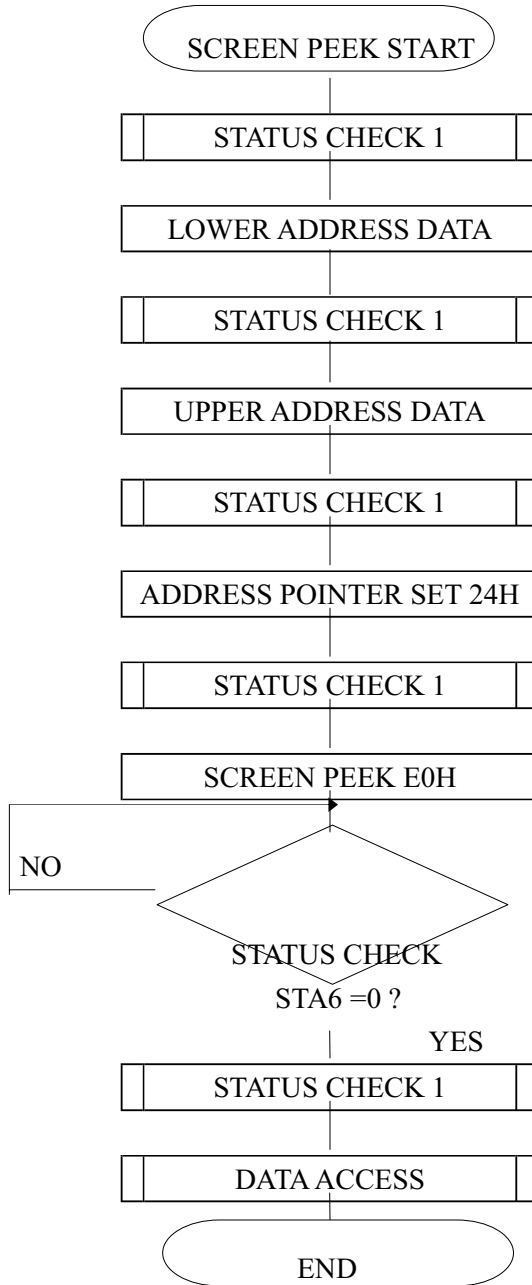

**9.Screen copy**

Code	Hex.	Function	Operand
11101000	E8H	screen copy	-

This command is used to copy displayed 1 line data to graphic area. The start point of 1 line data in



the screen is determined by the address pointer.

Note: (1) In attribute function, this command is invalid. (Because attribute data is in the graphic area.)

(2) In case of 2 screen drive, this command is invalid. (Because T693C cannot separate upper screen data and lower screen data.)

Please refer following flow chart.

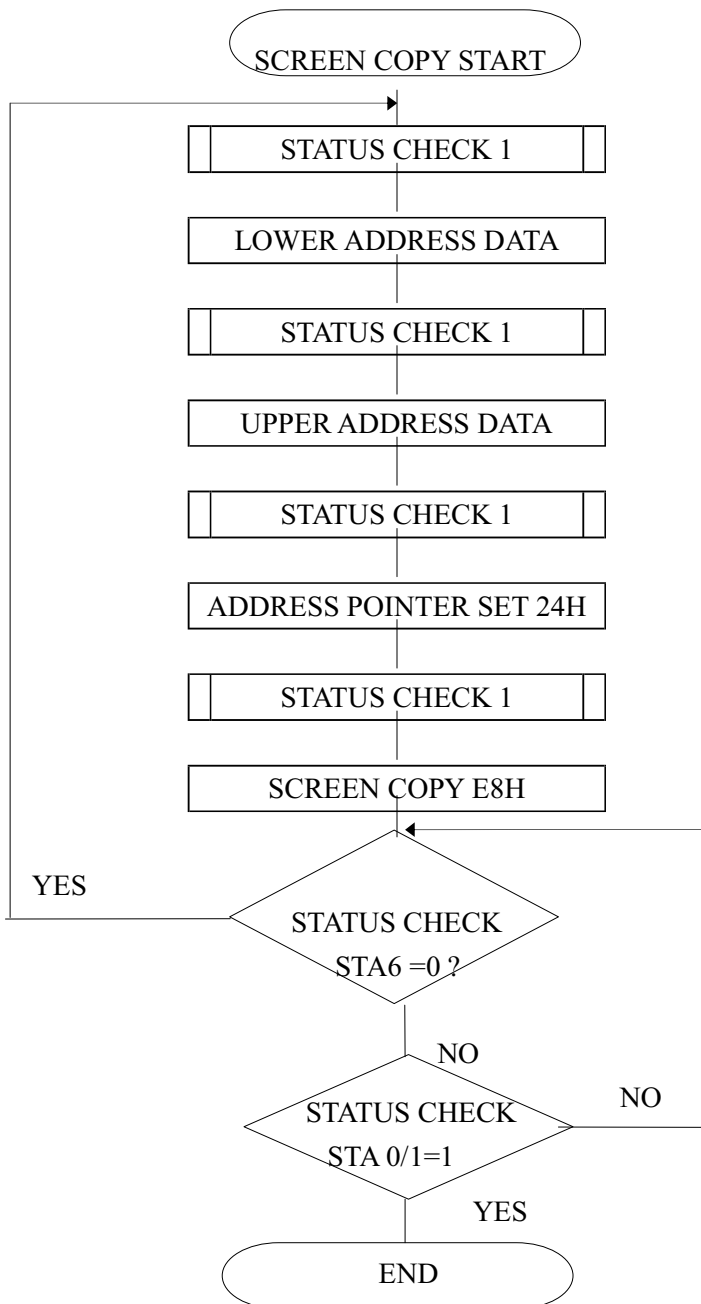

**10.Bit set/reset**

Code	Function	Operand
11110xxx	bit reset	-
11111xxx	bit set	-
1111x000	bit 9 (LSB)	-
1111x001	bit 1	-
1111x010	bit 2	-
1111x011	bit 3	-
1111x100	bit 4	-
1111x101	bit 5	-
1111x110	bit 6	-
1111x111	bit 7 (MSB)	-

This command is used to set or reset a bit of 1 byte is specified by address pointer. Plural bits in the 1 byte data cannot be set/reset at a time.

Please refer following flow chart.

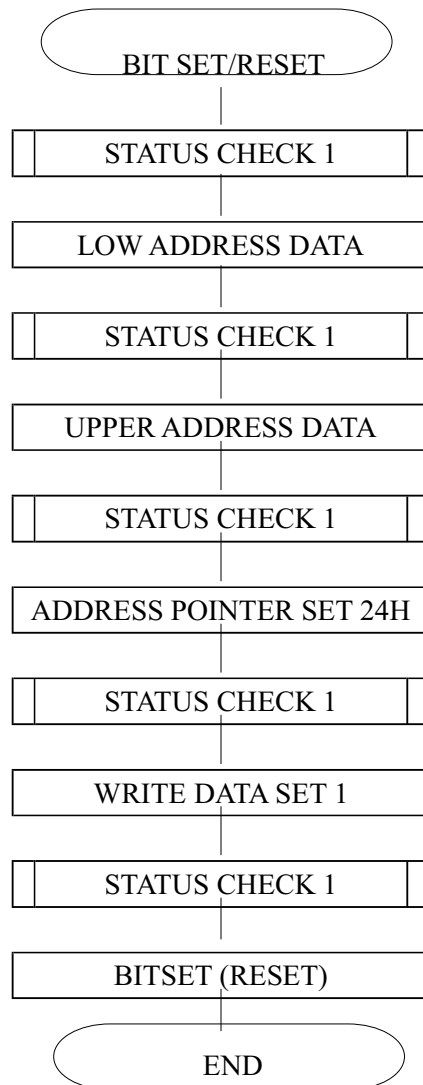



## • Command list

Command	Code	D1	D2	Function
Register Set	00100001	X address	Y address	Cursor pointer set
	00100010	Data	00H	Offset register set
	00100100	Low address	High address	Address pointer set
Control Word Set	01000000	Low address	High address	Text home address set
	01000001	Columns	00H	Text area set
	01000010	Low address	High address	Graphic home address set
	01000011	Columns	00H	Graphic area set
Mode Set	1000x000	-	-	“OR” mode
	1000x001	-	-	“EXOR” mode
	1000x011	-	-	“AND” mode
	1000x100	-	-	“Text attribute” mode
	10000xxx	-	-	“Internal CG ROM mode
	10001xxx	-	-	“External CG CG RAM mode
Display Mode	10010000	-	-	Display off
	1001xx10	-	-	Cursor on, blink off
	1001xx11	-	-	Cursor on, blink on
	100101xx	-	-	Text on, graphic off
	100110xx	-	-	Text off, graphic on
	100111xx	-	-	Text on, graphic on
Cursor Pattern Select	10100000	-	-	1 line cursor
	10100001	-	-	2 lines cursor
	10100010	-	-	3 lines cursor
	10100011	-	-	4 lines cursor
	10100100	-	-	5 lines cursor
	10100101	-	-	6 lines cursor
	10100110	-	-	7 lines cursor
	10100111	-	-	8 lines cursor
Data Auto Read/Write	10110000	-	-	Data auto write set
	10110001	-	-	Data auto read set
	10110010	-	-	Auto reset
Data Read Write	11000000	Data	-	Data write and ADP increment
	11000001	-	-	Data read and ADP increment
	11000010	Data	-	Data write and ADP decrement
	11000011	-	-	Data read and ADP decrement



	11000100	Data	-	Data write and ADP nonvariable
	11000101	-	-	Data read and ADP nonvariable
Screen Peek	11100000	-	-	Screen peek
Screen Copy	11101000			Screen copy
Bit Set/Reset	11110xxx	-	-	bit reset
	11111xxx	-	-	bit set
	1111x000	-	-	bit0 (LSB)
	1111x001	-	-	bit1
	1111x010	-	-	bit2
	1111x011	-	-	bit3
	1111x100	-	-	bit4
	1111x101	-	-	bit5
	1111x110	-	-	bit6
1111x111	-	-	bit7 (MSB)	





Item	Customer	Sales	R&D	Q.A	Manufacturing	Product control	Purchase	Inventory control
Sales Service	<pre> graph TD     Info[Info] --&gt; Claim[Claim]     Claim --&gt; FA[Failure analysis]     Claim --&gt; AR[Analysis report]     FA --&gt; CA[Corrective action]     CA --&gt; Tracking[Tracking]           </pre>							
Q.A Activity	1. ISO 9001 Maintenance Activities 3. Equipment calibration 5. Standardization Management				2. Process improvement proposal 4. Education And Training Activities			

### 3.2 Inspection Specification

- ◆ Inspection Standard : MIL-STD-105E Table Normal Inspection Single Sampling Level II .
- ◆ Equipment : Gauge 、 MIL-STD 、 **Sample**
- ◆ Defect Level : Major Defect AQL 0.4; Minor Defect AQL 1.5 .
- ◆ OUT Going Defect Level : Sampling .
- ◆ Manner of appearance test :
  - (1). The test be under 40W×2 fluorescent light ' and distance of view must be at 30 cm.
  - (2). The test direction is base on about around 45° of vertical line. (Fig. 1)
  - (3). Definition of area . (Fig. 2)

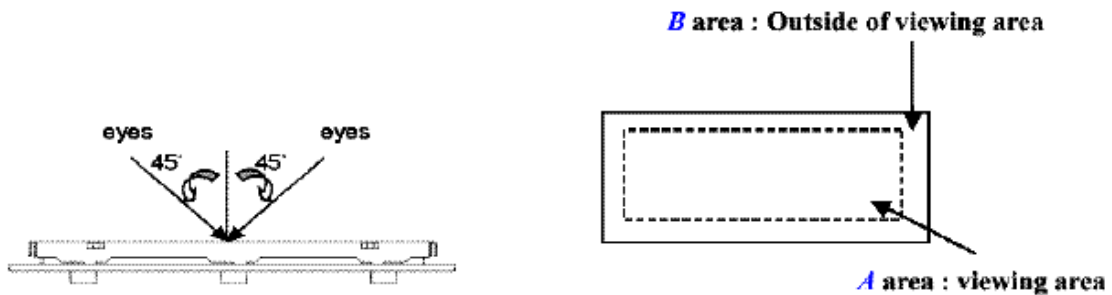



◆ Specification:



NO	Item	Criterion	level
01	Product condition	1.1 The part number is inconsistent with work order of Production.	Major
		1.2 Mixed production types.	Major
		1.3 Assembled in inverse direction.	Major
02	Quantity	2.1 The quantity is inconsistent with work order of production.	Major
03	Outline dimension	3.1 Product dimension and structure must conform to Structure diagram.	Major
04	Electrical Testing	4.1 Missing line character 、 dot and icon.	Major
		4.2 No function or no display.	Major
		4.3 Output data is error.	Major
		4.4 LCD viewing angle defect.	Major
		4.5 Current consumption exceeds product specifications.	Major
05	Black or white dot 、 scratch 、 contamination Round type	5.1 Round type: 5.1.1 display only : <ul style="list-style-type: none"> <li>• White and black spots on display <math>\leq 0.30\text{mm}</math>, no more than Four white or black spots present.</li> <li>• Densely spaced : NO more than two spots or lines within 3mm</li> </ul>	Minor

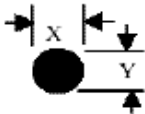
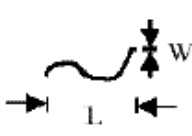

## ◆Specification :

NO	Item	Criterion	level																																	
05	Black or white dot、scratch、contamination Round type  $\Phi = (x+y)/2$ 	5.1.2 Nom-display : <table border="1" data-bbox="542 492 1292 694"> <thead> <tr> <th>Dimension (diameter : <math>\Phi</math>)</th> <th>Acceptance(Q'ty)</th> </tr> </thead> <tbody> <tr> <td><math>\Phi \leq 0.10\text{mm}</math></td> <td>Accept no dense</td> </tr> <tr> <td><math>0.10\text{mm} &lt; \Phi \leq 0.20\text{mm}</math></td> <td>3</td> </tr> <tr> <td><math>0.20\text{mm} &lt; \Phi \leq 0.30\text{mm}</math></td> <td>2</td> </tr> <tr> <td>Total</td> <td>4</td> </tr> </tbody> </table> 5.1.3 Line type: <table border="1" data-bbox="454 761 1324 1030"> <thead> <tr> <th colspan="2">Dimension (diameter : <math>\Phi</math>)</th> <th colspan="2">Acceptance (Q'ty)</th> </tr> <tr> <th>Length</th> <th>width</th> <th>A area</th> <th>B area</th> </tr> </thead> <tbody> <tr> <td>---</td> <td><math>w \leq 0.03\text{mm}</math></td> <td>Accept no dense</td> <td>Don't count</td> </tr> <tr> <td><math>L \leq 3.0\text{mm}</math></td> <td><math>0.03\text{mm} &lt; \Phi \leq 0.05\text{mm}</math></td> <td rowspan="2">4</td> <td>Don't count</td> </tr> <tr> <td><math>L \leq 2.5\text{mm}</math></td> <td><math>0.05\text{mm} &lt; \Phi \leq 0.075\text{mm}</math></td> <td>Don't count</td> </tr> <tr> <td>---</td> <td><math>w &gt; 0.075\text{mm}</math></td> <td colspan="2">As round type</td> </tr> </tbody> </table>	Dimension (diameter : $\Phi$ )	Acceptance(Q'ty)	$\Phi \leq 0.10\text{mm}$	Accept no dense	$0.10\text{mm} < \Phi \leq 0.20\text{mm}$	3	$0.20\text{mm} < \Phi \leq 0.30\text{mm}$	2	Total	4	Dimension (diameter : $\Phi$ )		Acceptance (Q'ty)		Length	width	A area	B area	---	$w \leq 0.03\text{mm}$	Accept no dense	Don't count	$L \leq 3.0\text{mm}$	$0.03\text{mm} < \Phi \leq 0.05\text{mm}$	4	Don't count	$L \leq 2.5\text{mm}$	$0.05\text{mm} < \Phi \leq 0.075\text{mm}$	Don't count	---	$w > 0.075\text{mm}$	As round type		Minor
Dimension (diameter : $\Phi$ )	Acceptance(Q'ty)																																			
$\Phi \leq 0.10\text{mm}$	Accept no dense																																			
$0.10\text{mm} < \Phi \leq 0.20\text{mm}$	3																																			
$0.20\text{mm} < \Phi \leq 0.30\text{mm}$	2																																			
Total	4																																			
Dimension (diameter : $\Phi$ )		Acceptance (Q'ty)																																		
Length	width	A area	B area																																	
---	$w \leq 0.03\text{mm}$	Accept no dense	Don't count																																	
$L \leq 3.0\text{mm}$	$0.03\text{mm} < \Phi \leq 0.05\text{mm}$	4	Don't count																																	
$L \leq 2.5\text{mm}$	$0.05\text{mm} < \Phi \leq 0.075\text{mm}$		Don't count																																	
---	$w > 0.075\text{mm}$	As round type																																		
06	Polarizer Bubble	<table border="1" data-bbox="454 1075 1324 1377"> <thead> <tr> <th rowspan="2">Dimension (diameter : <math>\Phi</math>)</th> <th colspan="2">Acceptance(Q'ty)</th> </tr> <tr> <th>A area</th> <th>B area</th> </tr> </thead> <tbody> <tr> <td><math>\Phi \leq 0.20\text{mm}</math></td> <td>Accept no dense</td> <td>Don't count</td> </tr> <tr> <td><math>0.20\text{mm} &lt; \Phi \leq 0.50\text{mm}</math></td> <td>3</td> <td>Don't count</td> </tr> <tr> <td><math>0.50\text{mm} &lt; \Phi \leq 1.00\text{mm}</math></td> <td>2</td> <td>Don't count</td> </tr> <tr> <td><math>\Phi &gt; 1.00\text{mm}</math></td> <td>0</td> <td>Don't count</td> </tr> <tr> <td>Total quantity</td> <td>4</td> <td>Don't count</td> </tr> </tbody> </table>	Dimension (diameter : $\Phi$ )	Acceptance(Q'ty)		A area	B area	$\Phi \leq 0.20\text{mm}$	Accept no dense	Don't count	$0.20\text{mm} < \Phi \leq 0.50\text{mm}$	3	Don't count	$0.50\text{mm} < \Phi \leq 1.00\text{mm}$	2	Don't count	$\Phi > 1.00\text{mm}$	0	Don't count	Total quantity	4	Don't count	Minor													
Dimension (diameter : $\Phi$ )	Acceptance(Q'ty)																																			
	A area	B area																																		
$\Phi \leq 0.20\text{mm}$	Accept no dense	Don't count																																		
$0.20\text{mm} < \Phi \leq 0.50\text{mm}$	3	Don't count																																		
$0.50\text{mm} < \Phi \leq 1.00\text{mm}$	2	Don't count																																		
$\Phi > 1.00\text{mm}$	0	Don't count																																		
Total quantity	4	Don't count																																		
07	The crack of glass 	● Glass Crack: 7.1 Crack on the circuit of electrode terminal : <table border="1" data-bbox="518 1713 1292 1859"> <thead> <tr> <th></th> <th>X</th> <th>Y</th> <th>Z</th> </tr> </thead> <tbody> <tr> <td>Front</td> <td><math>X \leq 1/5 a</math></td> <td><math>Y \leq 1/2 D</math></td> <td><math>Z \leq t</math></td> </tr> <tr> <td>Back</td> <td colspan="3">Neglect</td> </tr> </tbody> </table>		X	Y	Z	Front	$X \leq 1/5 a$	$Y \leq 1/2 D$	$Z \leq t$	Back	Neglect			Minor																					
	X	Y	Z																																	
Front	$X \leq 1/5 a$	$Y \leq 1/2 D$	$Z \leq t$																																	
Back	Neglect																																			

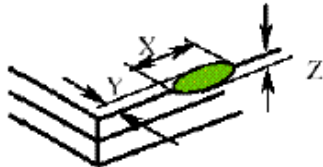
## ◆Specification :

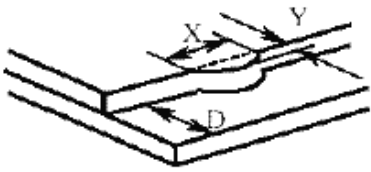
NO	Item	Criterion	Level												
07	The crack of glass X: The length of Crack Y: The width of crack Z: The thickness of crack D: terminal length T: The thickness of glass A : The length of glass	<p>● Glass Crack:</p> <p>7.2 General glass crack and corner edge:</p> <p>7.2.1</p>  <table border="1" data-bbox="560 831 1219 920"> <tr> <td>X</td> <td>Y</td> <td>Z</td> </tr> <tr> <td>Neglect</td> <td>Out A area</td> <td>Neglect</td> </tr> </table> <p>7.2.2</p>  <table border="1" data-bbox="560 1173 1219 1263"> <tr> <td>X</td> <td>Y</td> <td>Z</td> </tr> <tr> <td>Neglect</td> <td>Out A area</td> <td>Neglect</td> </tr> </table>	X	Y	Z	Neglect	Out A area	Neglect	X	Y	Z	Neglect	Out A area	Neglect	Minor
X	Y	Z													
Neglect	Out A area	Neglect													
X	Y	Z													
Neglect	Out A area	Neglect													
		<p>7.3 Glass remain:</p>  <table border="1" data-bbox="703 1697 1118 1794"> <tr> <td>X</td> <td>Y</td> </tr> <tr> <td>Neglect</td> <td><math>\leq 1/3 d</math></td> </tr> </table>	X	Y	Neglect	$\leq 1/3 d$	Minor								
X	Y														
Neglect	$\leq 1/3 d$														

◆Specification :

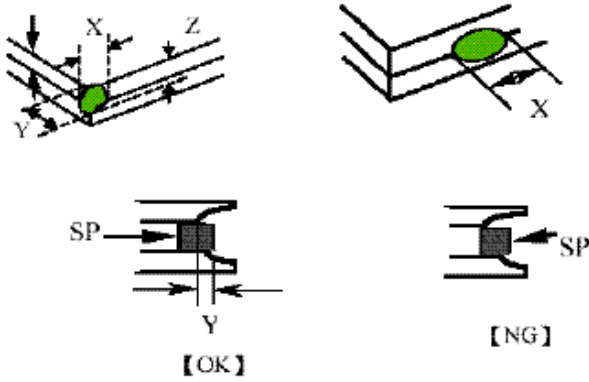
NO	Item	Criterion	Level									
07	<p>The crack of glass</p> <p>X: The length of Crack</p> <p>Y: The width of crack</p> <p>Z: The thickness of crack</p> <p>D: terminal length</p> <p>T: The thickness of glass</p> <p>A : The length of glass</p>	<p>7.4 Corner crack and medial crack:</p>  <table border="1" data-bbox="464 1014 1323 1193"> <thead> <tr> <th>X</th> <th>Y</th> <th>Z</th> </tr> </thead> <tbody> <tr> <td><math>\leq 1/5a</math></td> <td>Crack can't enter viewing area</td> <td><math>\leq 1/2t</math></td> </tr> <tr> <td><math>\leq 1/5a</math></td> <td>Crack can't exceed the half of width of SP</td> <td><math>1/2t &lt; Z \leq 2t</math></td> </tr> </tbody> </table>	X	Y	Z	$\leq 1/5a$	Crack can't enter viewing area	$\leq 1/2t$	$\leq 1/5a$	Crack can't exceed the half of width of SP	$1/2t < Z \leq 2t$	Minor
X	Y	Z										
$\leq 1/5a$	Crack can't enter viewing area	$\leq 1/2t$										
$\leq 1/5a$	Crack can't exceed the half of width of SP	$1/2t < Z \leq 2t$										
08	Backlight elements	<p>8.1 Backlight can't work normally.</p> <p>8.2 Backlight doesn't light or color is wrong.</p> <p>8.3 Illumination source flickers when lit.</p>	Major									
09	General appearance	<p>9.1 pin type must match type in specification sheet</p> <p>9.2 No short circuits in components on PCB or FPC</p> <p>9.3 Product packaging must the same as specified on packaging specification sheet.</p> <p>9.4 The folding and peeled off in polarizer are not acceptable</p> <p>9.5 The PCB or FPC between B/L assembled distance (PCB or FPC) is <math>\leq 1.5\text{mm}</math></p>	Major									



## 4. RELIABILITY TEST

### 4.1 Reliability Test Condition

NO.	TEST ITEM	TEST CONDITION										
1	High Temperature Storage Test	Keep in 80 ±2°C 96 hrs Surrounding temperature, then storage at normal condition 4hrs										
2	Low Temperature Storage Test	Keep in -30 ±2°C 96 hrs Surrounding temperature, then storage at normal condition 4hrs										
3	High Humidity Storage	Keep in +60°C/90%RH duration for 96 hrs Surrounding temperature, then storage at normal condition 4hrs (Excluding the polarizer)Or Keep in +40°C/90%RH duration for 96 hrs Surrounding temperature, then storage at normal condition 4hrs										
4	ESD Test	Air Discharge: Apply 6 KV with 5 times Discharge foreach polarity +/-										
		Contact Discharge: Apply 250V with 5 times discharge foreach polarity +/-										
4	ESD Test	1. Temperature ambinance:15°C ~ 35°C 2. Humidity relative:30%~60% 3. Energy Storage Capacitance(Cs+Cd):150pF±10% 4. Discharge Resistance(Rd):330Ω±10% 5. Discharge, mode of operation: Single Discharge (time between successive discharges at least 1 s) (Tolerance If the output voltage indication: ±5%)										
5	Temperature Cycling Test	-20°C → 25°C → 70°C → 25°C ← (30mins) (5mins) (30mins) (5mins) → 10 Cycle Surrounding temperature, then storage at normal condition 4hrs										
6	Vibration Test (Packaged)	1. Sine wave 10~55HZ frequency (1 min) 2. The amplitude of vibration :1.5 mm 3. Each direction (XYZ) duration for 2 Hrs										
7	Drop Test (Packaged)	<table border="1"> <thead> <tr> <th>Packing Weight (Kg)</th> <th>Drop Height (cm)</th> </tr> </thead> <tbody> <tr> <td>0 ~ 45.4</td> <td>122</td> </tr> <tr> <td>45.4 ~ 90.8</td> <td>76</td> </tr> <tr> <td>90.8 ~ 454</td> <td>61</td> </tr> <tr> <td>Over 454</td> <td>46</td> </tr> </tbody> </table>	Packing Weight (Kg)	Drop Height (cm)	0 ~ 45.4	122	45.4 ~ 90.8	76	90.8 ~ 454	61	Over 454	46
		Packing Weight (Kg)	Drop Height (cm)									
0 ~ 45.4	122											
45.4 ~ 90.8	76											
90.8 ~ 454	61											
Over 454	46											
		Drop direction :※3 comer /1 edges /6 sides etch 1times										

## 5. PRECAUTION RELATING PRODUCT HANDLING

### 5.1 SAFETY

- 5.1.1 If the LCD panel breaks , be careful not to get the liquid crystal to touch your skin.
- 5.1.2 If the liquid crystal touches your skin or clothes , please wash it off immediately by using soap and water.

### 5.2 HANDLING

- 5.2.1 Avoid any strong mechanical shock which can break the glass.
- 5.2.2 Avoid static electricity which can damage the CMOS LSI—When working with the module , be sure to ground your body and any electrical equipment you may be using.
- 5.2.3 Do not remove the panel or frame from the module.
- 5.2.4 The polarizing plate of the display is very fragile. So , please handle it very carefully ,do not touch , push or rub the exposed polarizing with anything harder than an HB pencil lead (glass , tweezers , etc.)
- 5.2.5 Do not wipe the polarizing plate with a dry cloth , as it may easily scratch the surface of plate.
- 5.2.6 Do not touch the display area with bare hands , this will stain the display area.
- 5.2.7 Do not use ketonics solvent & aromatic solvent. Use with a soft cloth soaked with a cleaning naphtha solvent.
- 5.2.8 To control temperature and time of soldering is  $320\pm 10^{\circ}\text{C}$  and 3-5 sec.
- 5.2.9 To avoid liquid (include organic solvent) stained on LCM .

### 5.3 STORAGE

- 5.3.1 Store the panel or module in a dark place where the temperature is  $25^{\circ}\text{C} \pm 5^{\circ}\text{C}$  and the humidity is below 65% RH.
- 5.3.2 Do not place the module near organics solvents or corrosive gases.
- 5.3.3 Do not crush , shake , or jolt the module.

### 5.4 TERMS OF WARRANTY

- 5.4.1 Applicable warrant period  
The period is within thirteen months since the date of shipping out under normal using and storage conditions.
- 5.4.2 Unaccepted responsibility  
This product has been manufactured to your company's specification as a part for use in your company's general electronic products. It is guaranteed to perform according to delivery specifications. For any other use apart from general electronic equipment , we cannot take responsibility if the product is used in nuclear power control equipment , aerospace equipment , fire and security systems or any other applications in which there is a direct risk to human life and where extremely high levels of reliability are required.