



MULTI-INNO TECHNOLOGY CO., LTD.

LCD MODULE SPECIFICATION

Model : MI12864AH-G

Revision	
Engineering	
Date	
Our Reference	



REVISION RECORD

Date	Ref. Page	Revision No.	Revision Items	Check & Approval
2002-11-28		Rev 1.0		

**1 General Specifications:**

1.1 Display type: FSTN

1.2 Display color :

Display color: Black

Background: White

1.3 Polarizer mode: Transflective/Positive

1.4 Viewing Angle: 6:00

1.5 Driving Method: 1/65 Duty 1/9 Bias

1.6 Without Backlight

1.7 Controller: S6B0724A01-B0CY

1.8 Data Transfer: Serial

1.9 Operating Temperature: -20----+70

Storage Temperature: -30----+80

1.10 Outline Dimensions: Refer to outline drawing on next page

1.11 Dot Matrix: 128X 64 DOTS

1.12 Dot Size: 0.4X0.28 (mm)

1.13 Dot Pitch: 0.42X0.3 (mm)

1.14 Weight: 25g

1.15 This module can be watched while wearing sunglasses.

Color tone is slightly changed by temperature and driving voltage.

2 Outline Drawing

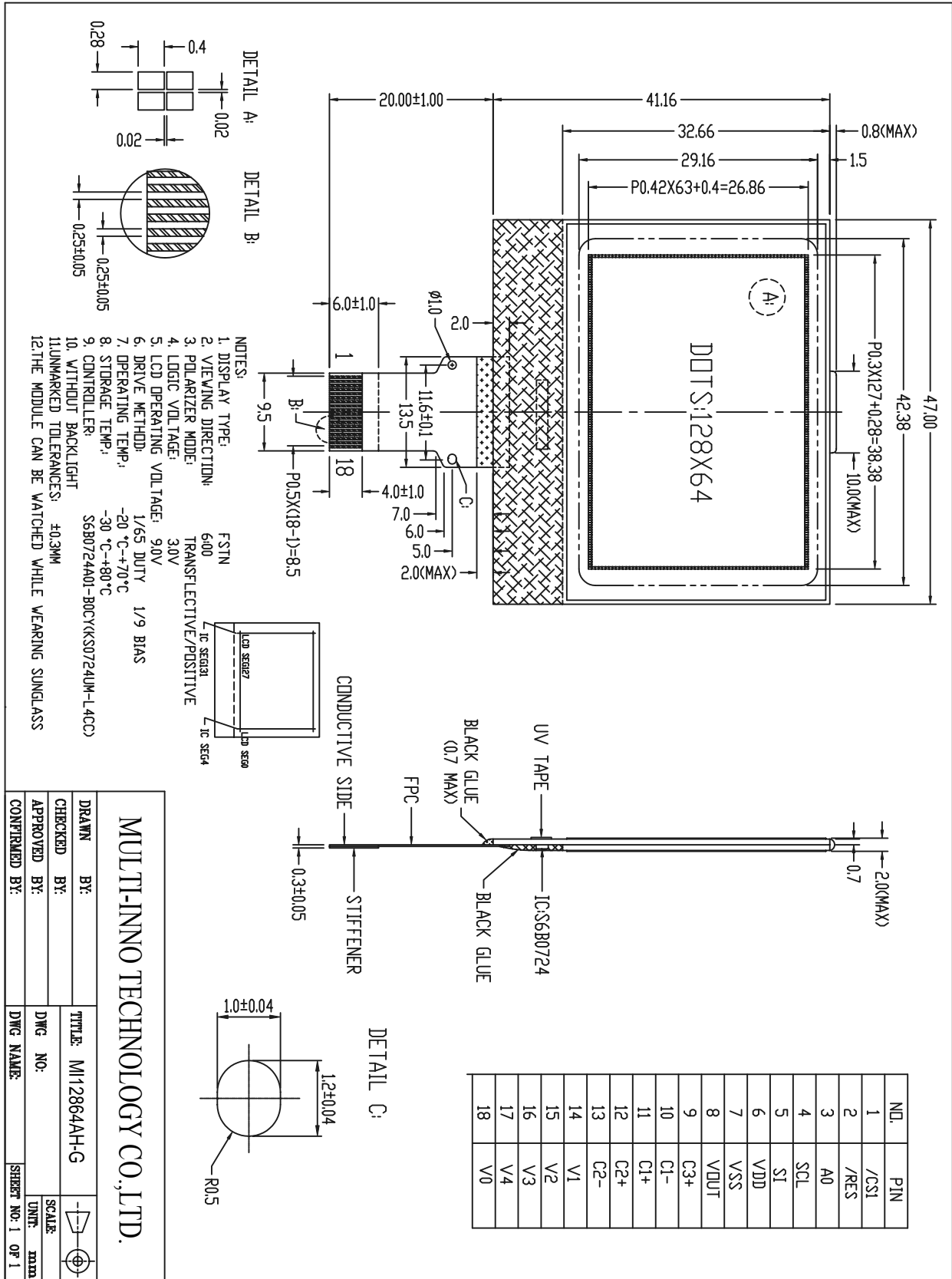



3 LCD Module Part Numbering System

MI 12864 AH - G

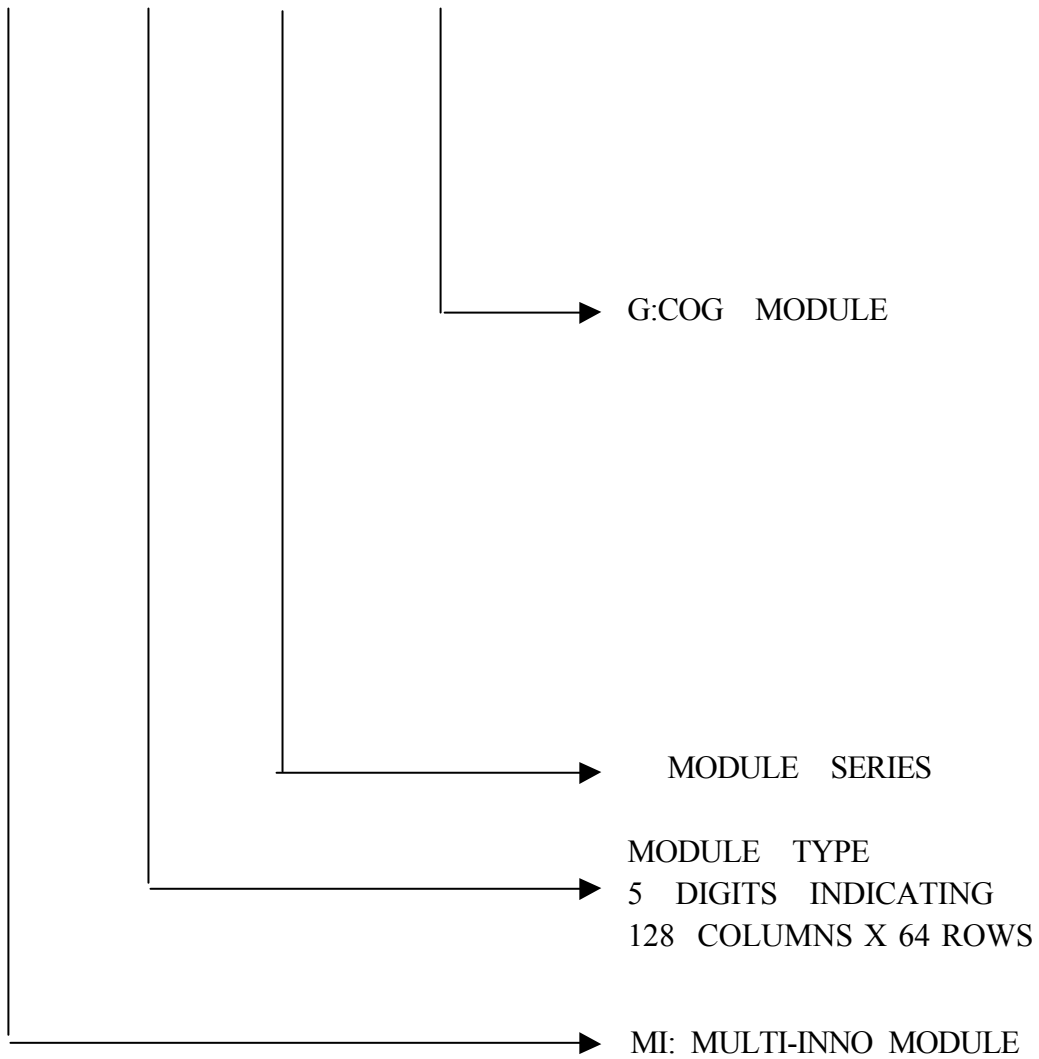

4 Circuit Block Diagram

4.1 Circuit Block Diagram

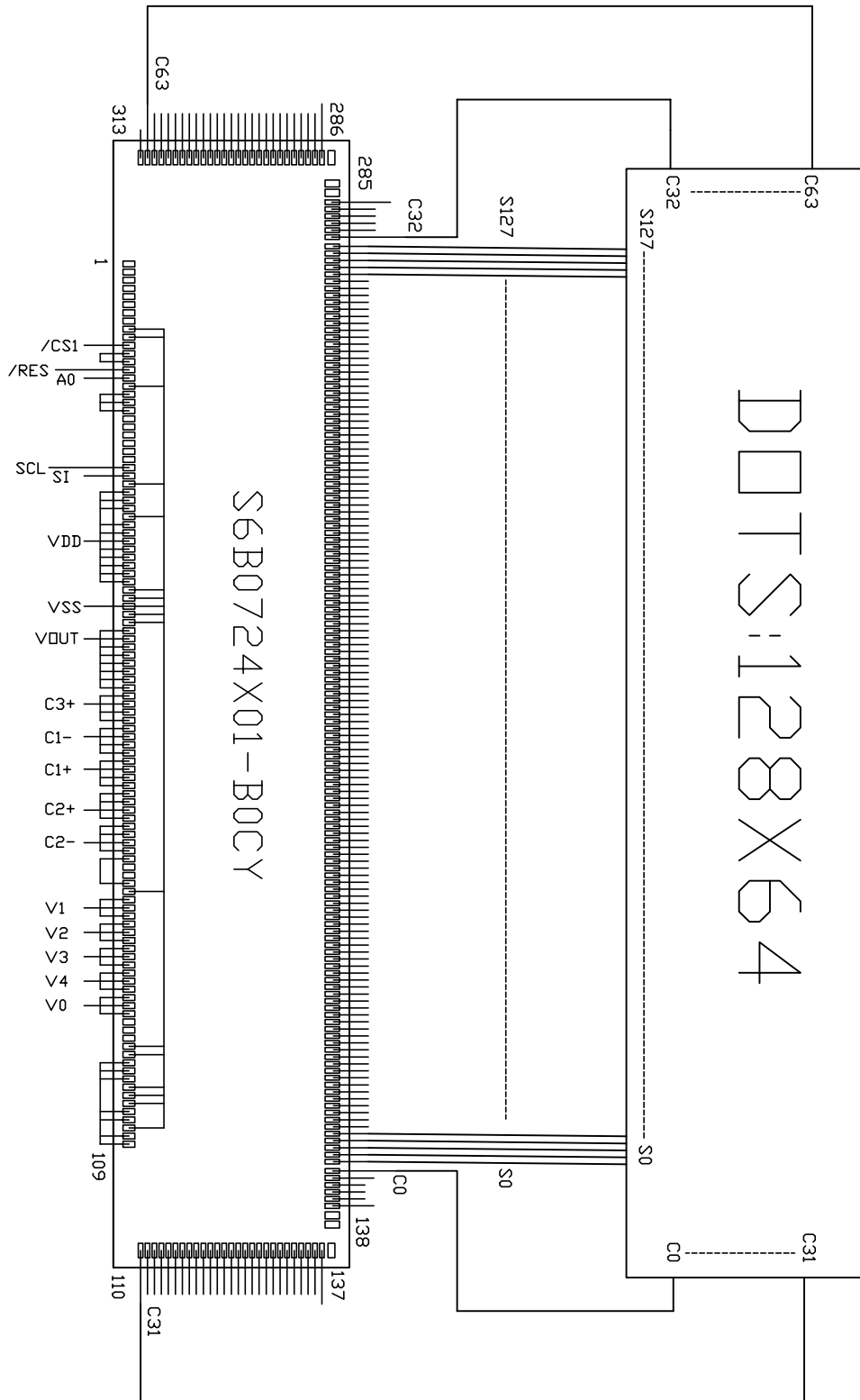

4.2 Power Supply Circuit

Reference Circuit(four times boosting circuit)

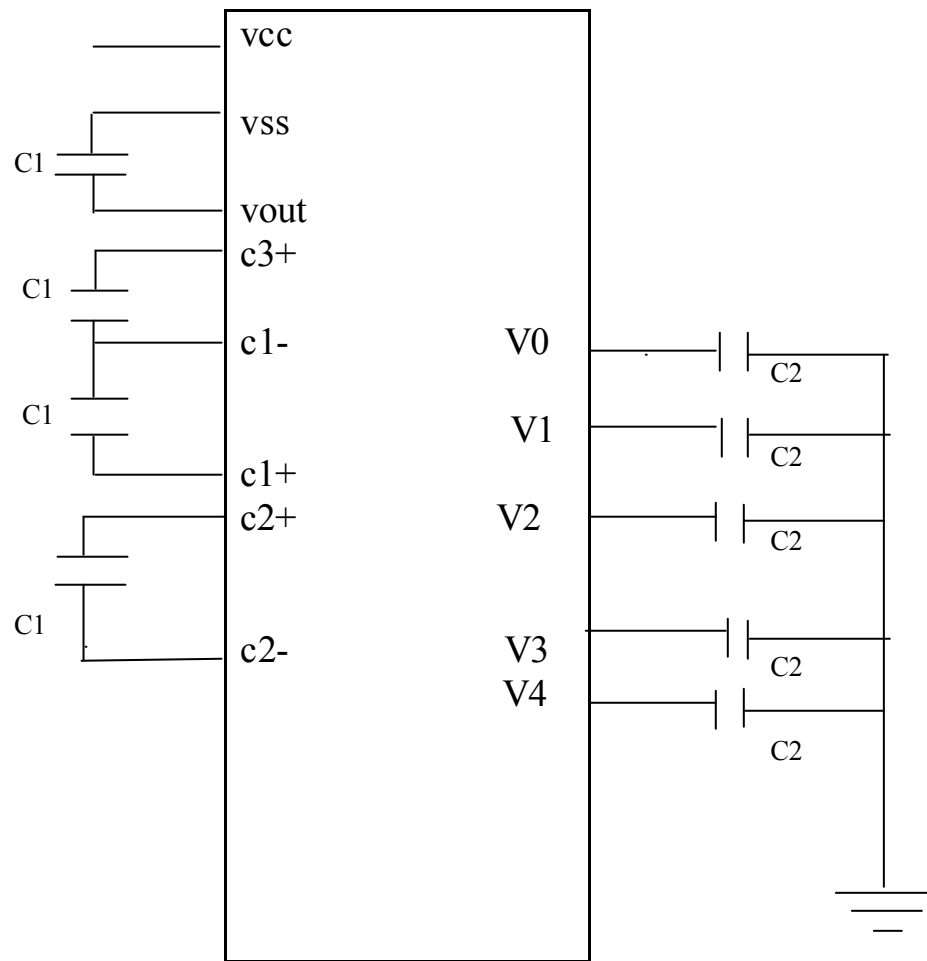

Reference :

C1=1.0---4.7uF

C2=0.47 1uF



5 Absolute Maximum Ratings

Item	Symbol	Min.	Max.	Unit	Remark
Power Supply Voltage	$V_{DD} - V_{SS}$	-0.3	7.0	V	
LCD Driving Voltage	V_{LCD}	-0.3	17.0		
Operating Temperature Range	T_{OP}	-20	+70		No Condensation
Storage Temperature Range	T_{ST}	-30	+80		



6 Electrical Specifications and Instruction Code

6.1 Electrical characteristics

Item	Symbol	Min.	Typ.	Max.	Unit
Supply Voltage (Logic)	$V_{DD} - V_{SS}$	2.4	3.0	3.6	V
Supply Voltage (LCD Drive)	V_{LCD}	4.5	9.0	15.0	V
Input Signal Voltage	High V_{IH} ($V_{DD}=3.0$)	$0.8V_{DD}$	-	V_{DD}	V
	Low V_{IL} ($V_{DD}=3.0$)	0	-	$0.2 V_{DD}$	V
Supply current (Logic)	I_{DD} ($V_{DD} - V_{SS} = 3.0$)	-	-	200	uA
Supply current (LED Backlight)	I_{BL}	-			mA



6.2 Interface Signals

Pin No.	Symbol	Level	Description
1	/CS1	H/L	Chip selects signal. L:Active
2	/RES	H/L	Reset Signal
3	A0	H/L	H: Input data are display data L: Input data are control data
4	SCL	H/L	Data bit 6 serves as the serial clock input terminal
5	SI	H/L	Data bit 7 serves as the serial data input terminal
6	VDD	3.0V	Power supply voltage for logic and step-up voltage
7	VSS	0V	Ground
8	VOOUT	-	DC/DC voltage converter output
9	C3+	-	Capacitor pin for voltage converter
10	C1-	-	Capacitor pin for voltage converter
11	C1+	-	Capacitor pin for voltage converter
12	C2+	-	Capacitor pin for voltage converter
13	C2-	-	Capacitor pin for voltage converter
14	V1	-	Power supply voltage for LCD
15	V2	-	Power supply voltage for LCD
16	V3	-	Power supply voltage for LCD
17	V4	-	Power supply voltage for LCD
18	V0	-	Power supply voltage for LCD

6.3 Interface Timing Chart

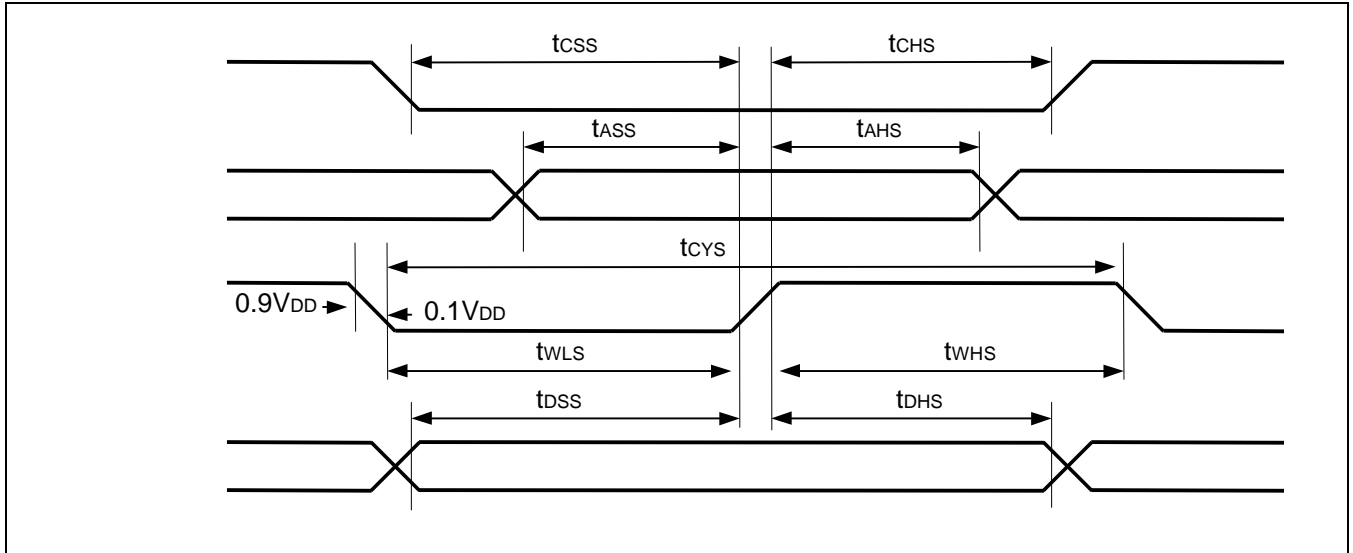

Figure 32. Serial Interface Characteristics

($V_{DD} = 2.4$ to $3.6V$, $T_a = -40$ to $+85^{\circ}C$)

Item	Signal	Symbol	Min.	Typ.	Max.	Unit	Remark
Serial clock cycle	DB6 (SCLK)	t_{CYS}	250	-	-	ns	
SCLK high pulse width		t_{WHS}	100	-	-		
SCLK low pulse width		t_{WLS}	100	-	-		
Address setup time	RS	t_{ASS}	150	-	-	ns	
Address hold time		t_{AHS}	150	-	-		
Data setup time	DB7 (SID)	t_{DSS}	100	-	-	ns	
Data hold time		t_{DHS}	100	-	-		
CS1B setup time	CS1B	t_{CSS}	150	-	-	ns	
CS1B hold time		t_{CHS}	150	-	-		



6.4 Instruction Code

Display ON / OFF	0	0	1	0	1	0	1	1	1	DON	Turn on/off LCD panel When DON = 0: display OFF When DON = 1: display ON
Initial display line	0	0	0	1	ST5	ST4	ST3	ST2	ST1	ST0	Specify DDRAM line for COM0
Set page address	0	0	1	0	1	1	P3	P2	P1	P0	Set page address
Set column address MSB	0	0	0	0	0	1	Y7	Y6	Y5	Y4	Set column address MSB
Set column address LSB	0	0	0	0	0	0	Y3	Y2	Y1	Y0	Set column address LSB
Read status	0	1	BUSY	ADC	ONOFF	RESETB	0	0	0	0	Read the internal status
Write display data	1	0	Write data							Write data into DDRAM	
Read display data	1	1	Read data							Read data from DDRAM	
ADC select	0	0	1	0	1	0	0	0	0	ADC	Select SEG output direction When ADC = 0: normal direction (SEG0→SEG131) When ADC = 1: reverse direction (SEG131→SEG0)
Reverse display ON / OFF	0	0	1	0	1	0	0	1	1	REV	Select normal / reverse display When REV = 0: normal display When REV = 1: reverse display
Entire display ON / OFF	0	0	1	0	1	0	0	1	0	EON	Select normal/entire display ON When EON = 0: normal display. When EON = 1: entire display ON
LCD bias select	0	0	1	0	1	0	0	0	1	BIAS	Select LCD bias
Set modify-read	0	0	1	1	1	0	0	0	0	0	Set modify-read mode
Reset modify-read	0	0	1	1	1	0	1	1	1	0	release modify-read mode
Reset	0	0	1	1	1	0	0	0	1	0	Initialize the internal functions
SHL select	0	0	1	1	0	0	SHL	×	×	×	Select COM output direction When SHL = 0: normal direction (COM0→COM63) When SHL = 1: reverse direction (COM63→COM0)
Power control	0	0	0	0	1	0	1	VC	VR	VF	Control power circuit operation
Regulator resistor select	0	0	0	0	1	0	0	R2	R1	R0	Select internal resistance ratio of the regulator resistor
Set reference voltage mode	0	0	1	0	0	0	0	0	0	1	Set reference voltage mode
Set reference voltage register	0	0	×	×	SV5	SV4	SV3	SV2	SV1	SV0	Set reference voltage register
Set static indicator mode	0	0	1	0	1	0	1	1	0	SM	Set static indicator mode
Set static indicator register	0	0	×	×	×	×	×	×	S1	S0	Set static indicator register
Power save	-	-	-	-	-	-	-	-	-	-	Compound Instruction of display OFF and entire display ON

**7 Optical Characteristics**

7.1 Optical Characteristics

Ta=25

Item	Symbol	Condition	Min.	Typ.	Max.	Unit
Viewing Angle	x	Cr=2	y=0 °	-30 -- 20		Deg
	y					
Contrast Ratio	Cr	x=0 ° y=0 °	3	-	-	
Response Time	Turn on	Ton	x=0 ° y=0 °	-	-	300
	Turn off					

7.2 Definition of Optical Characteristics

7.2.1 Definition of Viewing Angle

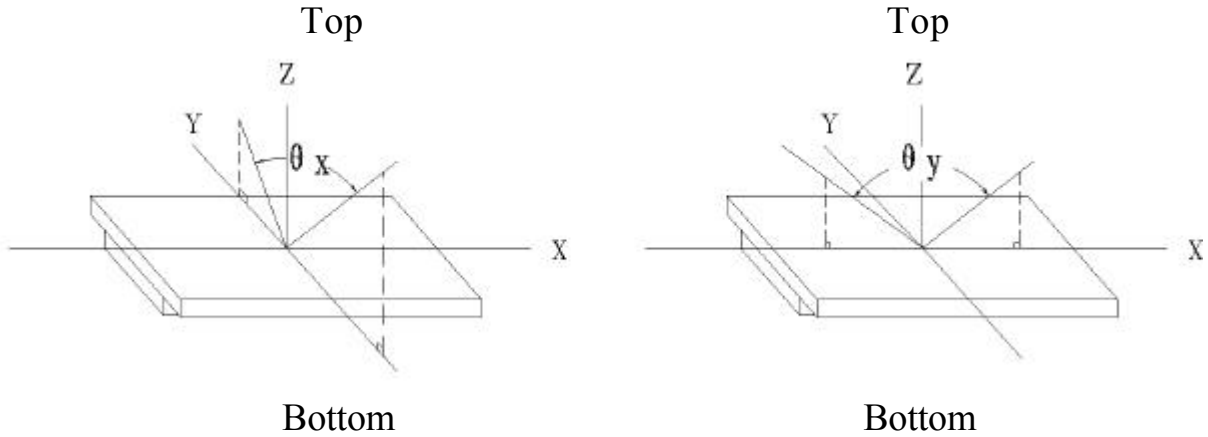

7.2.2 Definition of Contrast Ratio

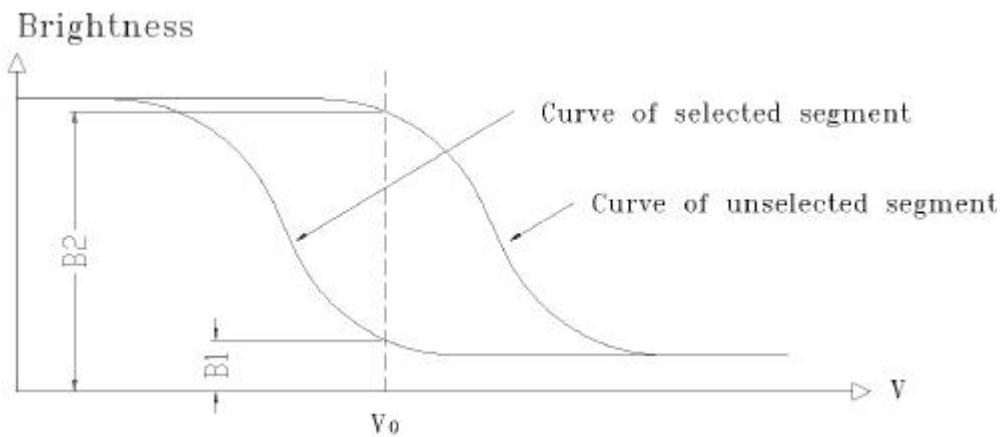

$$\text{Contrast Ratio} = B2/B1 = \frac{\text{unselected state brightness}}{\text{selected state brightness}}$$

Measuring Conditions:

- 1) Ambient Temperature: 25
- 2) Frame frequency: 100.0Hz

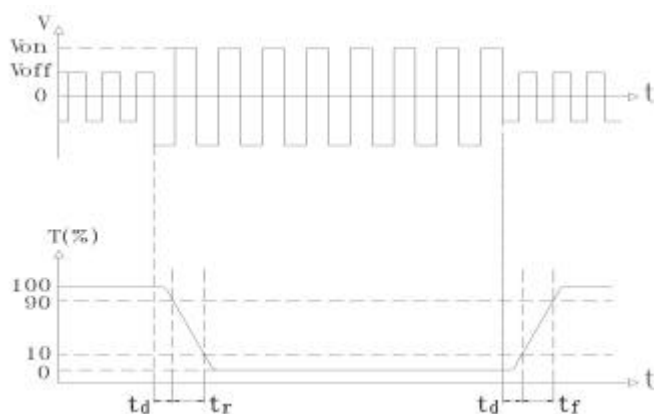

7.2.3 Definition of Response time



Turn on time: $t_{on} = t_d + t_r$ Turn off time: $t_{off} = t_d + t_f$

Measuring Condition:

1) Operating Voltage: 9.0V

2) Frame frequency: 100.0Hz

8 Reliability

8.1 Content of Reliability Test

Ta=25

No.	Test Item	Content of Test	Test condition
1	High Temperature Storage	Endurance test applying the high storage temperature for a long time	80 240H
2	Low Temperature Storage	Endurance test applying the low storage temperature for a long time	-30 240H
3	High Temperature Operation	Endurance test applying the electric stress (voltage & current) and the thermal stress to the element for a long time	70 240H
4	Low Temperature Operation	Endurance test applying the electric stress under low temperature for a long time	-20 240H
5	High Temperature /Humidity Storage	Endurance test applying the high temperature and high humidity storage for a long time	60 95%RH 240H
6	Temperature Cycle	Endurance test applying the low and high temperature cycle -30 25 80 25 30min 5min 30min 5min 1 cycle	-30 /80 10 cycles
7	Vibration Test (package state)	Endurance test applying the vibration during transportation	10Hz~500Hz, 100m/s ² , 120min
8	Shock Test (package state)	Endurance test applying the shock during transportation	Half- sine wave, 300m/s ² , 18ms
9	Atmospheric Pressure Test	Endurance test applying the atmospheric pressure during transportation by air	25kPa 16H

8.2 Failure Judgment Criterion

Criterion Item	Test Item No.									Failure Judgement Criterion
	1	2	3	4	5	6	7	8	9	
Basic Specification										Out of the basic Specification
Electrical specification										Out of the electrical specification
Mechanical Specification										Out of the mechanical specification
Optical Characteristic										Out of the optical specification
Note	For test item refer to 8.1									
Remark	Basic specification = Optical specification + Mechanical specification									



9 QUALITY LEVEL

Examination or Test	At $T_{amb}=25$ (unless otherwise stated)	Inspection				
		Min.	Max.	Unit	IL	AQL
External Visual Inspection	Under normal illumination and eyesight condition, the distance between eyes and LCD is 25cm.	See annex A			II	Major 1.0 Minor 2.5
Display Defects	Under normal illumination and eyesight condition, display on inspection.	See annex B			II	Major 1.0 Minor 2.5
Note: Major defects: Open segment or common, Short, Serious damages, Leakage Minor defects: Others Sampling standard conforms to GB2828						

10 Precautions for Use of LCD Modules

10.1 Handling Precautions

10.1.1 The display panel is made of glass. Do not subject it to a mechanical shock by dropping it from a high place, etc.

10.1.2 If the display panel is damaged and the liquid crystal substance inside it leaks out, be sure not to get any in your mouth, if the substance comes into contact with your skin or clothes, promptly wash it off using soap and water.

10.1.3 Do not apply excessive force to the display surface or the adjoining areas since this may cause the color tone to vary.

10.1.4 The polarizer covering the display surface of the LCD module is soft and easily scratched. Handle this polarizer carefully.

10.1.5 If the display surface is contaminated, breathe on the surface and gently wipe it with a soft dry cloth. If still not completely clear, moisten cloth with one of the following solvents:

- Isopropyl alcohol
- Ethyl alcohol

Solvents other than those mentioned above may damage the polarizer. Especially, do not use the following:

- Water
- Ketone
- Aromatic solvents

10.1.6 Do not attempt to disassemble the LCD Module.

10.1.7 If the logic circuit power is off, do not apply the input signals.

10.1.8 To prevent destruction of the elements by static electricity, be careful to maintain an optimum work environment.

- a. Be sure to ground the body when handling the LCD Modules.
- b. Tools required for assembly, such as soldering irons, must be properly ground.
- c. To reduce the amount of static electricity generated, do not conduct assembly and other work under dry conditions.
- d. The LCD Module is coated with a film to protect the display surface. Be care when peeling off this protective film since static electricity may be generated.



10.2 Storage precautions

10.2.1 When storing the LCD modules, avoid exposure to direct sunlight or to the light of fluorescent lamps.

10.2.2 The LCD modules should be stored under the storage temperature range.

If the LCD modules will be stored for a long time, the recommend condition is:

Temperature : 0 ~ 40

Relatively humidity: 80%

10.2.3 The LCD modules should be stored in the room without acid, alkali and harmful gas.

10.3 The LCD modules should be no falling and violent shocking during transportation, and also should avoid excessive press, water, damp and sunshine.

Appendix A

Inspection items and criteria for appearance defects

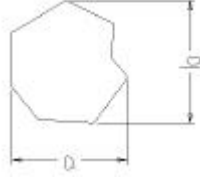
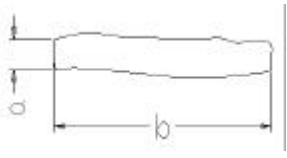
Items	Contents	Criteria			
Protective Glue		No clear defects			
Cover Tape		Covering all of the chip and no clear crimple			
Leakage		Not permitted			
Rainbow		According to the limit specimen			
Polarizer	Wrong polarizer attachment	Not permitted			
	Bubble between polarizer and glass	Not counted	Max. 3 defects allowed		
		$\phi < 0.3\text{mm}$	0.3mm ϕ 0.5mm		
	Scratches of polarizer	According to the limit specimen			
Black spot (in viewing area)		Not counted	Max. 3 spots allowed		
		$X < 0.20\text{mm}$	0.20mm X 0.5mm		
		$X = (a+b)/2$			Max. 3 spots (lines) allowed
Black line (in viewing area)		Not counted	Max. 3 lines allowed		
		$a < 0.02\text{mm}$	0.02mm a 0.05mm b 2.0mm		

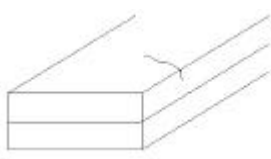
Progressive cracks		Not permitted	
--------------------	---	---------------	--

Appendix A

Inspection item and criteria for appearance defects (continued)

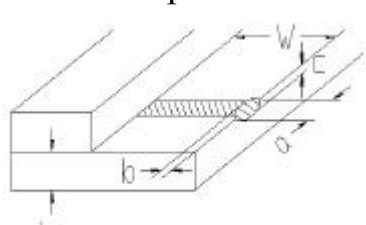
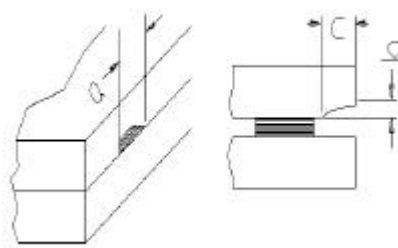
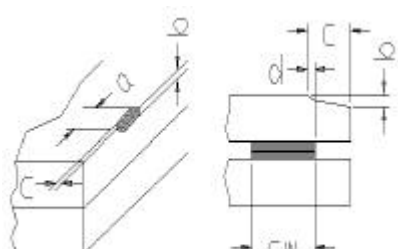
Items	Contents	Criteria							
Glass Cracks	Cracks on pads 	a	b	c	Max. 2 Cracks allowed	Max. 5 cracks allowed			
		3mm	W/5	T/2					
		2mm	W/5	$T/2 < C < T$					
	Cracks on contact side 	a	b		Max. 2 cracks allowed				
		3mm	T/2						
		2mm	$T/2 < b < T$						
		C shall be not reach the seal area							
	Cracks on non-contact side 	a	b					Max. 2 cracks allowed	
		3mm	T/2						
		2mm	$T/2 < b < T$						
		C 0.5mm							
		d SW/3							

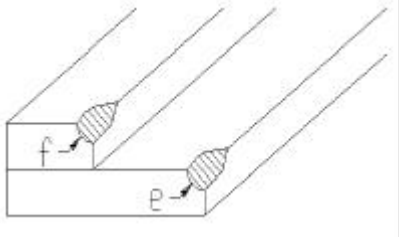
	Corner cracks 	$e < 2.0\text{mm}^2$ $f < 2.0\text{mm}^2$	Max. 3 cracks allowed	
--	--	--	-----------------------	--

Appendix B

Inspection items and criteria for display defects

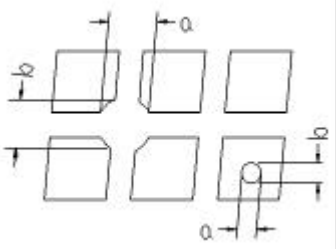
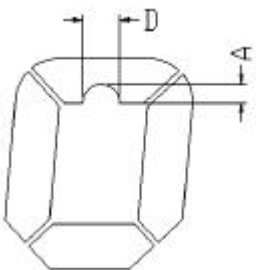
Items	Contents	Criteria		
Open segment or open common		Not permitted		
Short		Not permitted		
Wrong viewing angle		Not permitted		
Contrast ratio uneven		According to the limit specimen		
Crosstalk		According to the limit specimen		
Pin holes and cracks in segment (DOT)		Not counted	Max.3 dots allowed	Max.3 dots allowed
		$X < 0.1\text{mm}$	0.1mm X 0.2mm	
		$X = (a+b)/2$		
		Not counted	Max.2 dots allowed	
$A < 0.1\text{mm}$	$0.1\text{mm} \leq A < 0.2\text{mm}$ $D < 0.25\text{mm}$			

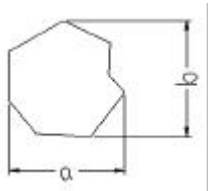
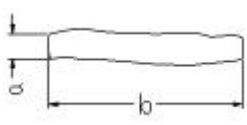
Black spot (in viewing area)		Not counted	Max.3 spots allowed	Max.3 spots (lines) allowed
		$X < 0.1\text{mm}$	0.1mm X 0.2mm	
		$X = (a+b)/2$		
Black line (in viewing area)		Not counted	Max.3 lines allowed	
		$a < 0.02\text{mm}$	0.02mm a 0.05mm b 0.5mm	

Appendix B

Inspection items and criteria for display defects (continued)

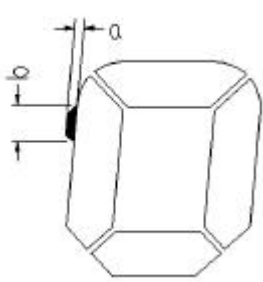
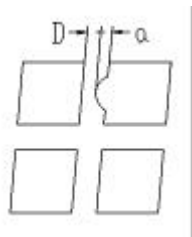
Items	Content	Criteria		
Transformation of segment		Not counted	Max. 2 defects allowed	Max.3 defects allowed
		$x < 0.1\text{mm}$	0.1mm x 0.2mm	
		$x = (a+b)/2$		
		Not counted	Max. 1 defects allowed	
		$a < 0.1\text{mm}$	0.1mm a 0.2mm $D > 0$	

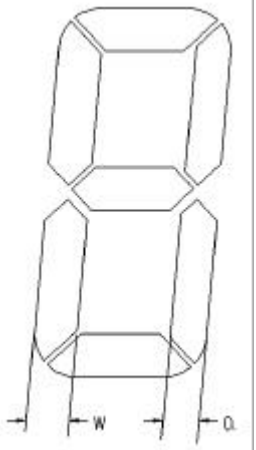
		<p>Max.2 defects allowed $0.8W \leq a \leq 1.2W$</p> <p>a=measured value of width W=nominal value of width</p>
--	---	---