



MULTI-INNO TECHNOLOGY CO., LTD.

LCD MODULE SPECIFICATION

Model : MI10656A-G-1

Revision	1.1
Engineering	
Date	
Our Reference	



REVISION RECORD

REV NO.	REV DATE	CONTENTS	REMARKS
0.1	2007-05-31	First Release	
1.1	2010-06-28	Change IC	P.5;P6;P8;P10; P11;P15.

TABLE OF CONTENTS

<u>ITEM</u>	<u>REVISION RECORD</u>	<u>PAGE</u>
1.	<i>COVER</i> _____	<1>
2.	<i>REVISION RECORD</i> _____	<2>
3.	<i>TABLE OF CONTENTS</i> _____	<3>
4.	<i>GENERAL INFORMATION</i> _____	<4>
5.	<i>OPTICAL DEFINITIONS</i> _____	<4>
6.	<i>OUTLINE AND MECHANICAL DESCRIPTION</i> _____	<5>
7.	<i>ELECTRICAL DESCRIPTION</i> _____	<7>
8.	<i>QUALITY AND RELIABILITY</i> _____	<16>
9.	<i>PACKING</i> _____	<20>
10.	<i>CAUTION FOR USING LCM</i> _____	<21>

1. GENERAL INFORMATION

1.1 SCOPE:

This specification covers the delivery requirements for the LCM delivered by Multi-Inno Technology Co.,Ltd to Customer.

1.2 PRODUCT ELEMENT

LCD,FPC, IC.ETC

1.3 MODULE NAME

MI10656A-G-1

1.4 ENVIRONMENT DESCRIPTION.

RoHS Compliant.

2. OPTICAL DEFINITIONS

2.1 Definition of angle θ and ϕ

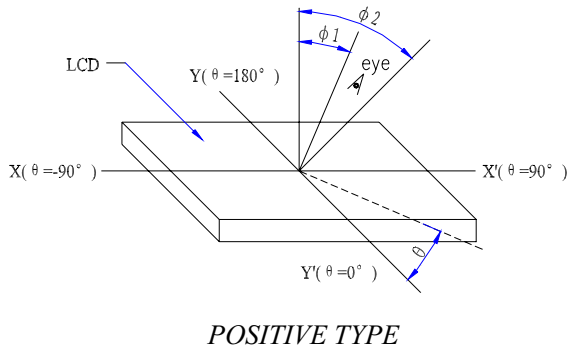

2.2 Definition of viewing angle $\phi 1$ and $\phi 2$

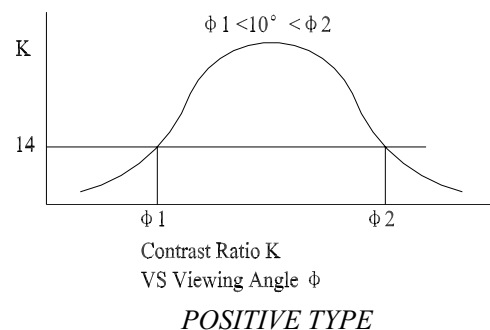

2.3 Definition of contrast “K”

$$K = \frac{\text{brightness of non-selected segment (B2)}}{\text{brightness of selected segment (B1)}}$$

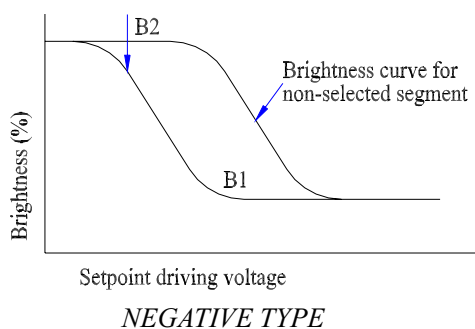

2.4 Definition of optical response

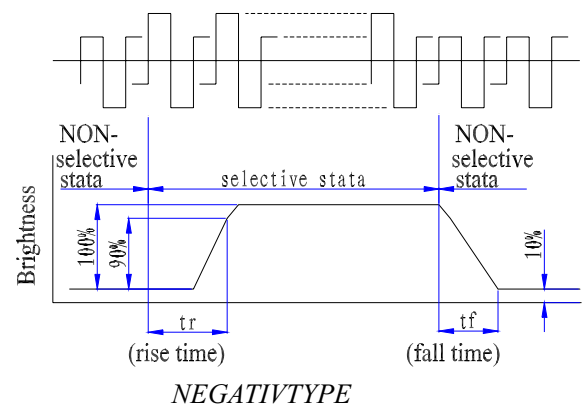

2.5 Definition of contrast “K”

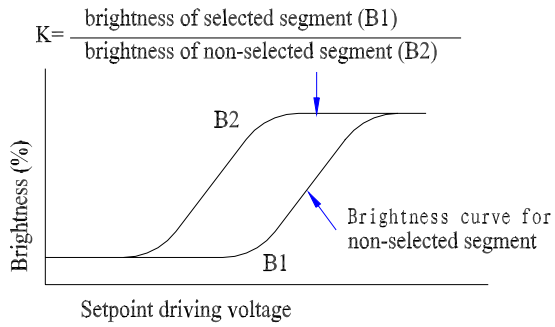

2.6 Definition of optical response

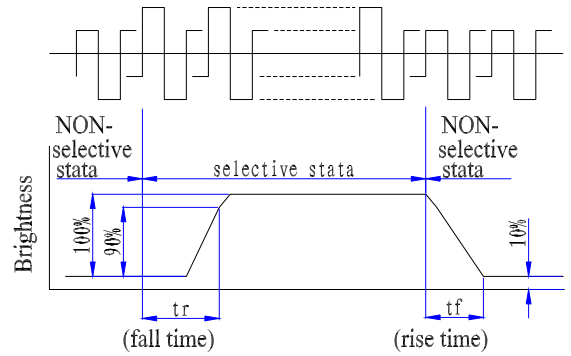

3.OUTLINE AND MECHANICAL DESCRIPTION

3.1 OUTLINE

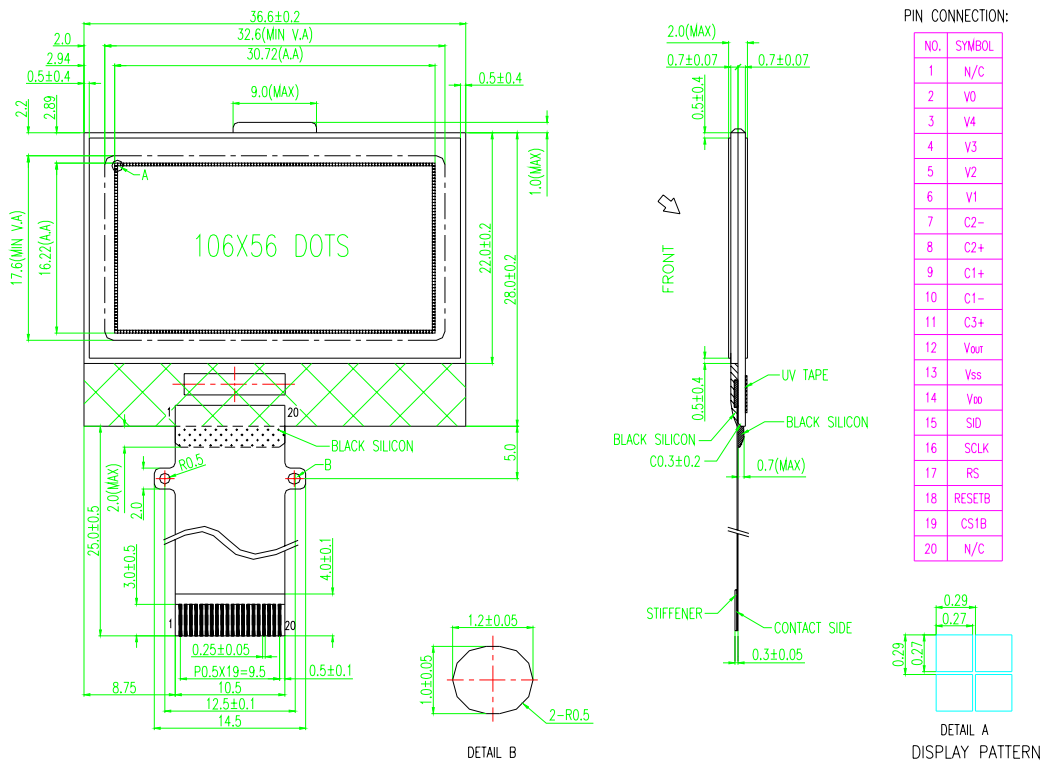

PIN CONNECTION:

NO.	SYMBOL
1	N/C
2	V0
3	V4
4	V3
5	V2
6	V1
7	C2-
9	C1+
10	C1-
11	C3+
12	Vout
13	Vss
14	Vin
15	SID
16	SCLK
17	RS
18	RESETB
19	CS1B
20	N/C

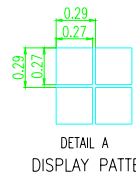

NOTES:

1. DISPLAY TYPE: FSTN MODE, REFLECTIVE/POSITIVE.
2. DRIVEMETHOD: DUTY=1/65, BIAS=1/9, VDD=3.0V, VOP=9.5V.
3. VIEWING DIRECTION: 12 O'CLOCK.
4. DRIVER: ST7565R
5. OPERATING TEMP: 0°C ~ 50°C.
6. STORAGE TEMP: -20°C ~ 60°C.
7. UNMARKED TOLERANCE: ±0.3mm.
8. RoHS COMPLIANT.



3.2 MECHANICAL DESCRIPTION

Item.	Standard Value	Unit
Lcm Size	36.6*28	mm
Dot Size	0.27*0.27	mm
Dot Number	2936	dots
Dot Pitch	0.29*0.29	mm
View Area	61.8*25.2	mm
Action Area	30.72*16.22	mm
Assy.Type	COG	--
View Direction	<input type="checkbox"/> 3H <input type="checkbox"/> 6H <input type="checkbox"/> 9H <input checked="" type="checkbox"/> 12H <input type="checkbox"/> OTHER	--
Lcd Type	<input type="checkbox"/> TN <input type="checkbox"/> HTN <input type="checkbox"/> STN GRAY <input type="checkbox"/> STN BLUE <input type="checkbox"/> STN YELLOW-GREEN <input checked="" type="checkbox"/> FSTN B/W <input type="checkbox"/> OTHER	--
Display Mode	<input checked="" type="checkbox"/> Positive <input type="checkbox"/> Negative	--
Rear Polarizer	<input checked="" type="checkbox"/> Reflective <input type="checkbox"/> Transflective <input type="checkbox"/> Transmissive	--
Backlight Type	<input type="checkbox"/> LED <input type="checkbox"/> EL <input type="checkbox"/> CCFL <input type="checkbox"/> Bottom <input type="checkbox"/> Edge	--
	Led Voltage: Lightness: --	--
Backlight Color	<input type="checkbox"/> White <input type="checkbox"/> Yellow-Green <input type="checkbox"/> Blue	--
	<input type="checkbox"/> Amber <input type="checkbox"/> Other	--
Temperature Range	<input checked="" type="checkbox"/> Normal <input type="checkbox"/> Wide <input type="checkbox"/> Super Wide	--
	Operating Temp: 0°C~50°C Store Temp: -20°C~70°C	--
Drive Method	Duty: 1/65 Bias: 1/9	--
	VDD: 3.0 VOP: 9.5	V
Drive IC	ST7565R	--
Weight	--	g

4.ELECTRICAL DESCRIPTION

4.1 Input Signal Function

No.	Symbol	Function	Note
1	NC		
2	VO	This is a multi-level power supply for the liquid crystal Drive. The voltage Supply applied is determined by the liquid crystal cell and is changed through. the use of a resistive voltage divided or through changing the impedance using an op. amp. Voltage levels are determined based on VSS, and must maintain are relative magnitudes shown below. $V0 \cong V1 \cong V2 \cong V3 \cong V4 \cong VSS$ When the power supply turns on, the internal power supply circuits produce the V1 to V4 voltages shown bellow the voltages settings are selected using the LCD bias set command. Power Supply for Driving the LCD.LCD driver supply voltages	
3	V4		
4	V3		
5	V2		
6	V1		
7	C2-	DC/DC voltage converter. Connect a capacitor between this terminal and the CAP2N terminal.	
8	C2+	DC/DC voltage converter. Connect a capacitor between this terminal and the CAP2P terminal.	
9	C1+	DC/DC voltage converter. Connect a capacitor between this terminal and the CAP1P terminal.	
10	C1-	DC/DC voltage converter. Connect a capacitor between this terminal and the CAP1N terminal.	
11	C3+	DC/DC voltage converter. Connect a capacitor between this terminal and the CAP3P terminal.	
12	Vout	DC/DC voltage converter. Connect a capacitor between this terminal and VSS or VDD.	
13	Vss	Ground (0V)	
14	VDD	Shared with the MPU power supply terminal VCC	
15	SCL (CLK)	Serial clock input.(D6)	
16	SI (DATA)	Serial data input.(D7)	
17	RS	RS="H":Indicates that D0 to D7 are display data. RS="L":Indicates that D0 to D7 are control data.	
18	RESET	When /RES is set to "L",the setting is initialized. The reset operation is performed by the /RES signal level.	
19	/CS	Chip select signal. Active "L"	
20	NC		

4.2 Block diagram

Single Chip Structure (1/65 Duty Configurations)

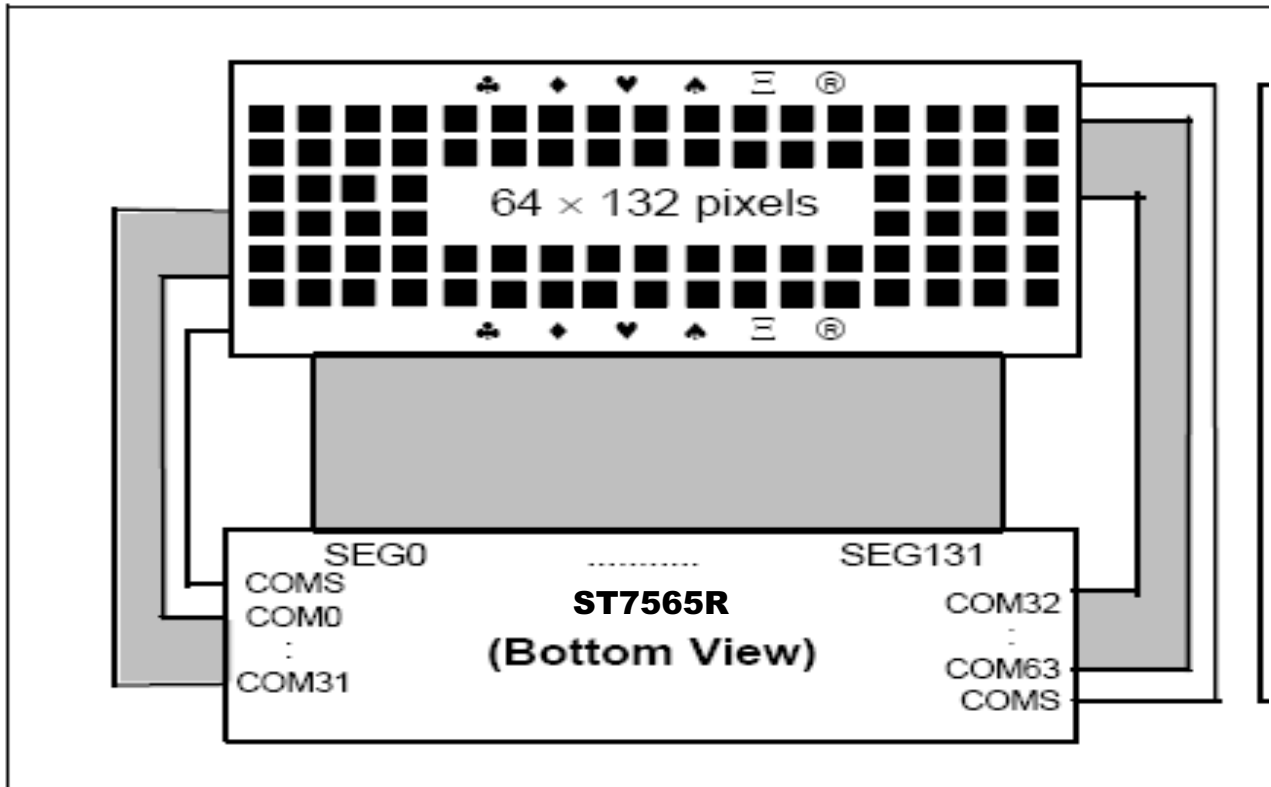

Figure 38. SHL = 1, ADC = 0

4.3 Instruction

The ST7565R is a single chip driver & controller LSI for graphic dot-matrix liquid crystal display systems. This chip can be connected directly to a microprocessor, accepts serial or 8-bit parallel display data from the microprocessor, stores the display data in an on-chip display data RAM of 65 x 132 bits and generates a liquid crystal display drive signal independent of the microprocessor. It provides a high-flexible display section due to 1-to-1 correspondence between on-chip display data RAM bits and LCD panel pixels. It contains 65 common driver circuits and 132 segment driver circuits, so that a single chip can drive a 65 x 132 dot display. And the capacity of the display can be increased through the use of master/slave multi-chip structures. These chips are able to minimize power consumption because they perform display data RAM read/write operations with no external operation clock. In addition, because they contain power supply circuits necessary to drive liquid crystal, which is a display clock oscillator circuit, high performance voltage converter circuit, high-accuracy voltage regulator circuit, low power consumption voltage divider resistors and OP-Amp for liquid crystal driver power voltage, it is possible to make the lowest power consumption display system with the fewest components for high

4.4 FEATURES

Display Driver Output Circuits

- 65 common outputs / 132 segment outputs

On-chip Display Data RAM

- Capacity: $65 \times 132 = 8,580$ bits
- RAM bit data "1": a dot of display is illuminated.
- RAM bit data "0": a dot of display is not illuminated.

Applicable Duty Ratios

Duty ratio	Applicable LCD bias	Maximum display area
1/65	1/7 or 1/9	65×132
1/55	1/6 or 1/8	55×132
1/49	1/6 or 1/8	49×132
1/33	1/5 or 1/6	33×132

Microprocessor Interface

- High-speed 8-bit parallel bi-directional interface with 6800-series or 8080-series
- Serial interface (only write operation) available

4.5 Electrical Absolute Maximum Rating

ABSOLUTE MAXIMUM RATINGS

Table 19. Absolute Maximum Ratings

Parameter	Symbol	Rating	Unit
Supply voltage range	VDD	- 0.3 to +7.0	V
	VLCD	- 0.3 to +17.0	V
Input voltage range	VIN	- 0.3 to VDD + 0.3	V
Operating temperature range	TOPR	- 40 to +85	°C
Storage temperature range	TSTR	- 55 to +125	°C

NOTES:

1. VDD and VLCD are based on VSS = 0V.
2. Voltages $V0 \geq V1 \geq V2 \geq V3 \geq V4 \geq VSS$ must always be satisfied. (VLCD = V0 - VSS)
3. If supply voltage exceeds its absolute maximum range, this LSI may be damaged permanently. It is desirable to use this LSI under electrical characteristic conditions during general operation. Otherwise, this LSI may malfunction or reduced LSI reliability may result.

4.6 Function Description

MICROPROCESSOR INTERFACE

Chip Select Input

There are CS1B and CS2 pins for chip selection. The ST7565R can interface with an MPU only when CS1B is "L" and CS2 is "H". When these pins are set to any other combination, RS, E_RDB, and RW_WRB inputs are disabled and DB0 to DB7 are to be high impedance. And, in case of serial interface, the internal shift register and the counter are reset.

Parallel / Serial Interface

ST7565R has three types of interface with an MPU, which are one serial and two parallel interfaces. This parallel or serial interface is determined by PS pin as shown in table 8.

Table 8. Parallel / Serial Interface Mode

PS	Type	CS1B	CS2	C68	Interface mode
H	Parallel	CS1B	CS2	H	6800-series MPU mode
				L	8080-series MPU mode
L	Serial	CS1B	CS2	*x	Serial-mode

Serial Interface (PS = "L")

When the ST7565R is active, serial data (DB7) and serial clock (DB6) inputs are enabled. And not active, the internal 8-bit shift register and the 3-bit counter are reset. Serial data can be read on the rising edge of serial clock going into DB6 and processed as 8-bit parallel data on the eighth serial clock. Serial data input is display data when RS is high and control data when RS is low. Since the clock signal (DB6) is easy to be affected by the external noise caused by the line length, the operation check on the actual machine is recommended.

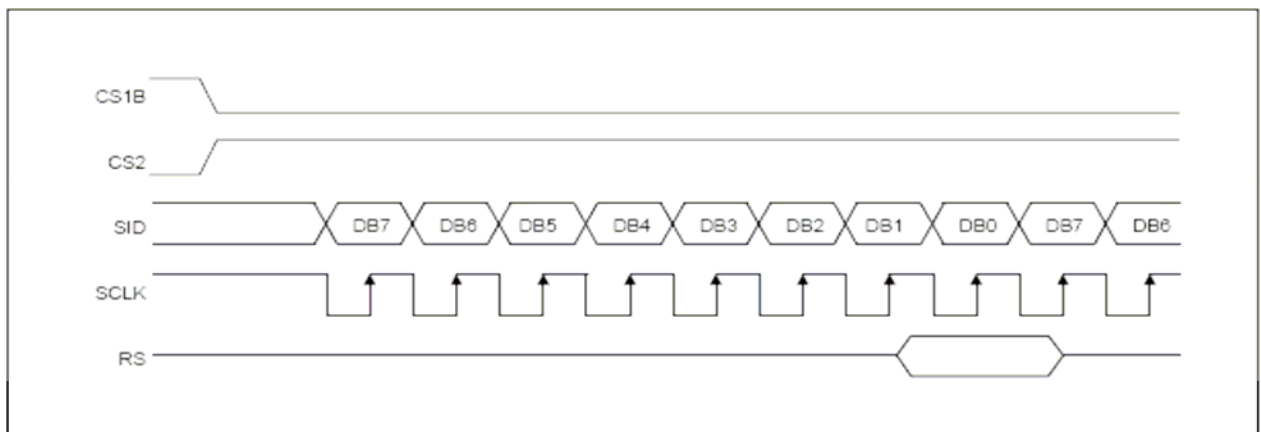

Figure 3. Serial Interface Timing

Busy Flag

The Busy Flag indicates whether the ST7565R is operating or not. When DB7 is "H" in read status operation, this device is in busy status and will accept only read status instruction. If the cycle time is correct, the microprocessor needs not to check this flag before each instruction, which improves the MPU performance.

Data Transfer

The ST7565R uses bus holder and internal data bus for data transfer with the MPU. When writing data from the MPU to on-chip RAM, data is automatically transferred from the bus holder to the RAM as shown in figure 4. And when reading data from on-chip RAM to the MPU, the data for the initial read cycle is stored in the bus holder (dummy read) and the MPU reads this stored data from bus holder for the next data read cycle. This means that a dummy read cycle must be inserted between each pair of address sets when a sequence of address sets is executed. Therefore, the data of the specified address cannot be output with the read display data instruction right after the address sets, but can be output at the second read of data.

4.7 Instruction Description

×: Don't care

Instruction	RS	RW	DB7	DB6	DB5	DB4	DB3	DB2	DB1	DB0	Description
Display ON / OFF	0	0	1	0	1	0	1	1	1	DON	Turn on/off LCD panel When DON = 0: display OFF When DON = 1: display ON
Initial display line	0	0	0	1	ST5	ST4	ST3	ST2	ST1	ST0	Specify DDRAM line for COM0
Set page address	0	0	1	0	1	1	P3	P2	P1	P0	Set page address
Set column address MSB	0	0	0	0	0	1	Y7	Y6	Y5	Y4	Set column address MSB
Set column address LSB	0	0	0	0	0	0	Y3	Y2	Y1	Y0	Set column address LSB
Read status	0	1	BUSY	ADC	ONOFF	RESET	0	0	0	0	Read the internal status
Write display data	1	0	Write data								Write data into DDRAM
Read display data	1	1	Read data								Read data from DDRAM
ADC select	0	0	1	0	1	0	0	0	0	ADC	Select SEG output direction When ADC = 0: normal direction (SEG0→SEG131) When ADC = 1: reverse direction (SEG131→SEG0)
Reverse display ON / OFF	0	0	1	0	1	0	0	1	1	REV	Select normal / reverse display When REV = 0: normal display When REV = 1: reverse display
Entire display ON / OFF	0	0	1	0	1	0	0	1	0	EON	Select normal/entire display ON When EON = 0: normal display. When EON = 1: entire display ON

LCD bias select	0	0	1	0	1	0	0	0	1	BIAS	Select LCD bias
Set modify-read	0	0	1	1	1	0	0	0	0	0	Set modify-read mode
Reset modify-read	0	0	1	1	1	0	1	1	1	0	release modify-read mode
Reset	0	0	1	1	1	0	0	0	1	0	Initialize the internal functions
SHL select	0	0	1	1	0	0	SHL	x	x	x	Select COM output direction When SHL = 0: normal direction (COM0→COM63) When SHL = 1: reverse direction (COM63→COM0)
Power control	0	0	0	0	1	0	1	VC	VR	VF	Control power circuit operation
Regulator resistor select	0	0	0	0	1	0	0	R2	R1	R0	Select internal resistance ratio of the regulator resistor
Set reference voltage mode	0	0	1	0	0	0	0	0	0	1	Set reference voltage mode
Set reference voltage register	0	0	x	x	SV5	SV4	SV3	SV2	SV1	SV0	Set reference voltage register
Set static indicator mode	0	0	1	0	1	0	1	1	0	SM	Set static indicator mode
Set static indicator register	0	0	x	x	x	x	x	x	S1	S0	Set static indicator register
Power save	-	-	-	-	-	-	-	-	-	-	Compound Instruction of display OFF and entire display ON

Referential Instruction Setup Flow

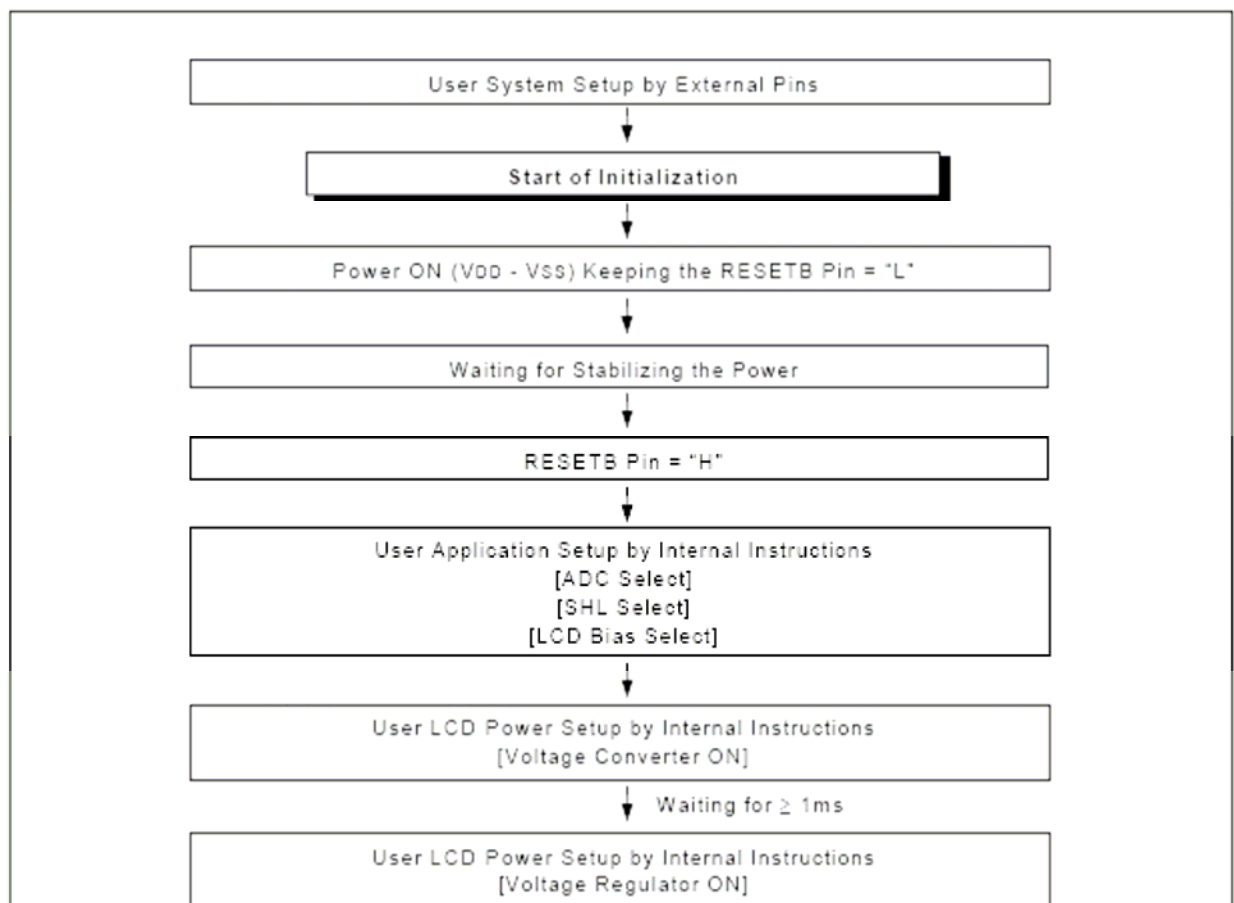

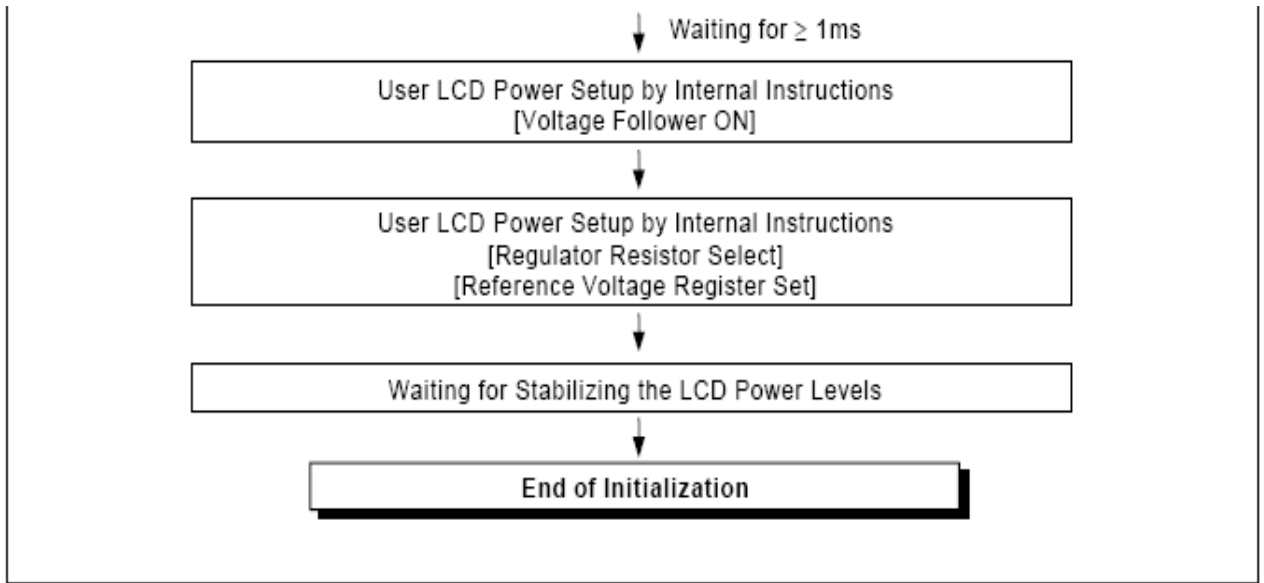

Serial Interface Characteristics

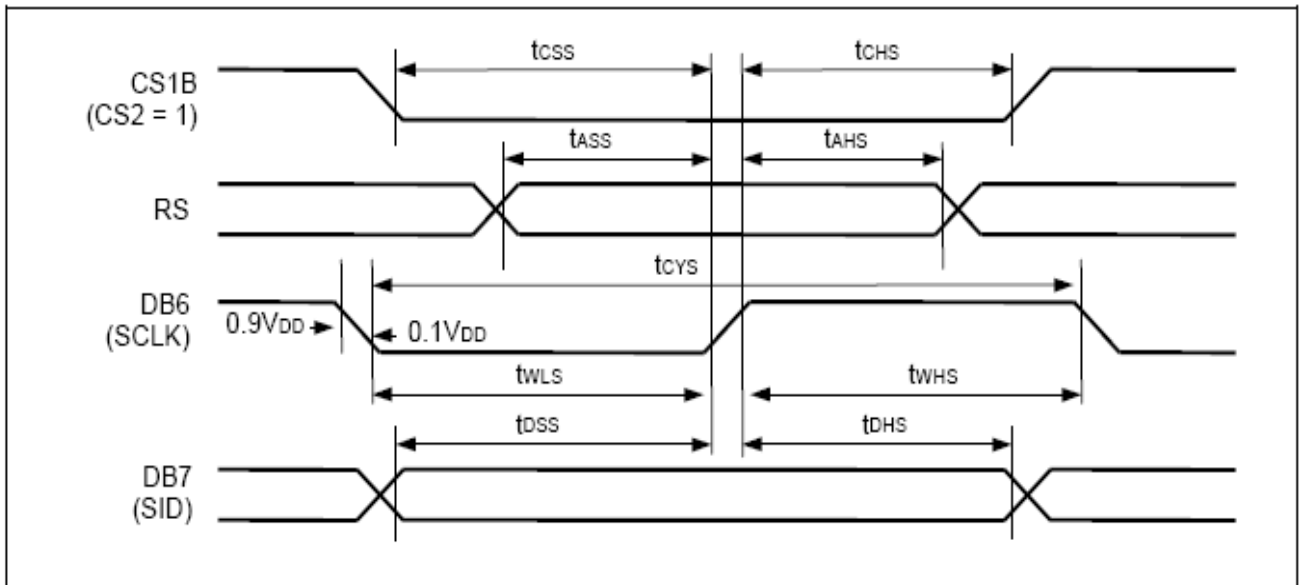

($V_{DD} = 2.4$ to $3.6V$, $T_a = -40$ to $+85^{\circ}C$)

Item	Signal	Symbol	Min.	Typ.	Max.	Unit	Remark
Serial clock cycle	DB6 (SCLK)	t_{CYS}	250	-	-	ns	
SCLK high pulse width		t_{WHS}	100	-	-		
SCLK low pulse width		t_{WLS}	100	-	-		
Address setup time	RS	t_{ASS}	150	-	-	ns	
Address hold time		t_{AHS}	150	-	-		
Data setup time	DB7 (SID)	t_{DSS}	100	-	-	ns	
Data hold time		t_{DHS}	100	-	-		
CS1B setup time	CS1B	t_{CSS}	150	-	-	ns	
CS1B hold time		t_{CHS}	150	-	-		

4.8 Electrical Characteristics

DC CHARACTERISTICS

(VSS = 0V, VDD = 2.4 to 3.6V, Ta = -40 to 85°C)

Item	Symbol	Condition	Min.	Typ.	Max.	Unit	Pin used	
Operating voltage (1)	VDD		2.4	-	3.6	V	VDD *1	
Operating voltage (2)	V0		4.5	-	15.0	V	V0 *2	
Input voltage	High	VIH	0.8VDD	-	VDD	V	*3	
	Low	VIL	VSS	-	0.2VDD			
Output voltage	High	VOH	IOH = -0.5mA	0.8VDD	-	VDD	V	*4
	Low	VOL	IOL = 0.5mA	VSS	-	0.2VDD		
Input leakage current	IIL	VIN = VDD or VSS	- 1.0	-	+ 1.0	μA	*5	
Output leakage current	IOZ	VIN = VDD or VSS	- 3.0	-	+ 3.0	μA	*6	
LCD driver ON resistance	RON	Ta = 25°C, V0 = 8V	-	2.0	3.0	kΩ	SEGN COMn *7	
Oscillator frequency	Internal	fOSC	Ta = 25°C Duty ratio = 1/85	32.7	43.6	54.5	kHz	CL *8
	External	fCL		4.09	5.45	6.81		
Voltage converter input voltage	VCI	× 2	2.4	-	3.6	V	VCI	
		× 3	2.4	-	3.6			
		× 4	2.4	-	3.6			
		× 5	2.4	-	3.2			
Voltage converter output voltage	VOUT	×2 / ×3 / ×4 / ×5 voltage conversion (no-load)	95	99	-	%	VOUT	
Voltage regulator operating voltage	VOUT		6.0	-	16.0	V	VOUT	
Voltage follower operating voltage	V0		4.5	-	15.0	V	V0 *9	
Reference voltage	VREF	Ta = 25°C	- 0.05%/°C	2.04	2.1	2.16	V	*10

MICROPROCESSOR INTERFACE

In Case of Serial Interface (PS = "L", C68 = "H or L")

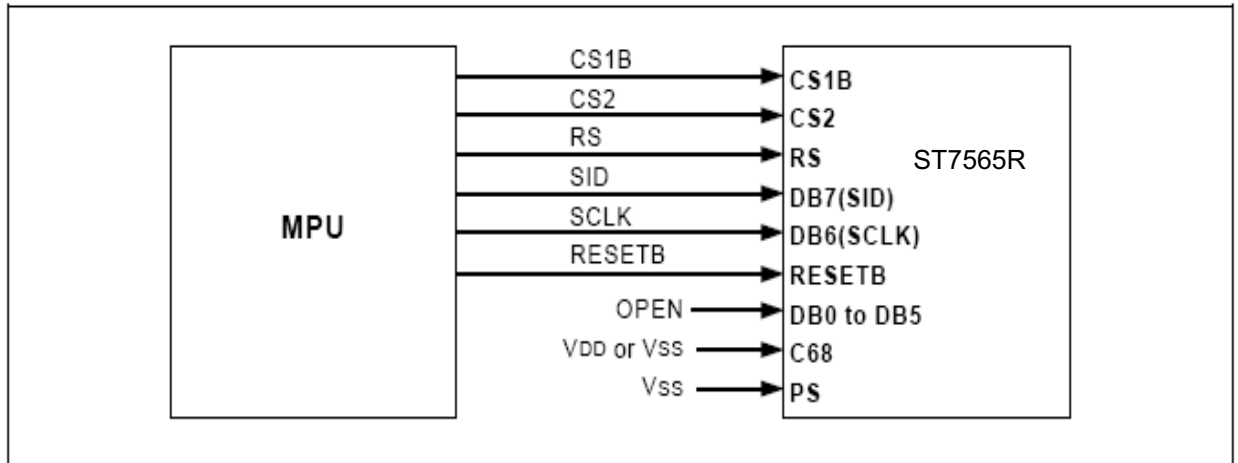

Figure 37. Serial Interface (PS = "L", C68 = "H or L")

5. QUALITY AND RELIABILITY

5.1 Test Condition

Test should be conducted under the following conditions:

Ambient Temperature: 25 ± 5 °C

Humidity : 60 ± 20% RH

5.2 Sampling Plan

Sampling method shall be in accordance with inspection level II, normal inspection, and single sampling plan tables for normal tightened, and reduced inspection.

5.3 Acceptable Quality Level

A major defect is a defect that could result in failure or materially reduce that the usability of the unit of product for its intended purpose.

A minor defect is one that does not materially reduce the usability of the unit of product for its intended purpose or is a departure from established standards having no significant bearing on the effective use or operation of the unit.

5.4 Appearance and Checking Standard

5.4.1 Appearance

Appearance test is to be conducted by eyes at approximately 30cm distance from LCD module under the single fluorescent light.

5.4.2 Checking Standard

Inspection level:

Sampling procedure: General inspection levels II and single sampling plans for normal inspection of ISO2859.

Item	Indication	AQL
Major Nonconformity (MA)	Function	0.4
	Size	
Minor Nonconformity (MI)	Effects on LCD appearance but not on function	1.0

5.4.2.1 Inspection condition:

1. The inspection should be done under 40W fluorescent light and visual inspection distance is 30cm.
2. Back-Lights or reflective boards should be adopted for inspecting transmissive LCDs.
3. The visual direction should be viewing angle range
4. This kind of situation will be judged qualificatory one that defection of product in B area won't effect customer's assembly and product quality

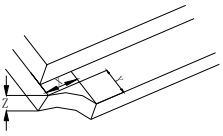
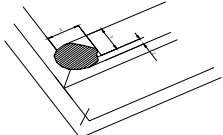
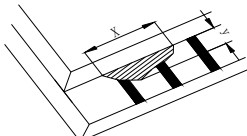
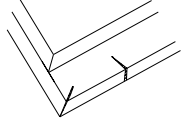
Item		Figure 示意图	Criteria 判断标准	MA MI
Glass Nonconformity 玻璃不良	Glass Corner Breakage 角破损		1、 $X \leq 3\text{mm}$ and don't touch pin $X \leq 3\text{mm}$ 和不到达 PIN 的引线 2、Y out of seal resin Y 不进入框线 3、Z ignore ACC Z 不计 接收	MI
			1、 $X \leq 1/8$ Length of LCD side $X \leq 1/8$ 边长 2、Y out of area A Y 不进入可视区 3、 $Z \leq t$ Z don't touch seal resin ACC $Z \leq t$ Z 不到达框线 接收	
	Extra Glass Ledge 突出		1、X ignore X 不计 2、 $Y \leq 1/3$ Length of conductor ACC $Y \leq 1/3$ PIN 长 接收	MI
Glass Nonconformity 玻璃破损	Crack 裂缝		Any crack any where 任何区域有裂痕	REJ 拒收 MA

Glass Nonconformity 玻璃不良	Glass Side Breakage 边破损		1、 $X \leq 1/4$ Length of LCD side $X \leq 1/4$ 边长 2、Y out of area A Y 不进入可视区 3、 $Z \leq t$ Z don't touch seal resin ACC 接收 $Z \leq t$ Z 不到达框线	MI			
			1、 $X \leq 1/4$ Length of LCD side $X \leq 1/4$ LCD 边长 $Y \leq 1/3L$ (L: Length of conductor) $Y \leq 1/3$ PIN 宽 3、 $Z \leq t$ Z don't touch seal resin ACC 接收 $Z \leq t$ Z 不到达框线	MI			
Color Variation 彩虹			At most 2-color samples are acceptable but have no color difference in the brightest state. ACC 接收 无明显两色之分	MI			
Point Like flaw 点状不良			$\phi = (x+y) / 2$ $\phi \leq 0.25\text{mm}$ Distance between 2 spots $> 5\text{mm}$ $\phi = (x+y) / 2$ $\phi \leq 0.25\text{mm}$ 两点间距 $> 5\text{mm}$	ACC 接收 MI			
Scratching Line 线状刮伤			$X \leq 6\text{mm}$ $Y \leq 0.08\text{mm}$ $X \leq 6\text{mm}$ $Y \leq 0.08\text{mm}$	ACC 接收 MI			
Polarizer Nonconformity 偏光片不良	Deflective Sticking 贴歪		According to the tolerance specified in engineering drawing. 符合工程图要求的公差 接收	MI			
	Faulty Sticking 贴错		REJ 拒收	MA			
	Air Bubble 气泡		$\Phi = (X+Y) / 2$ <table border="1"> <thead> <tr> <th>Size (mm) 尺寸</th> <th>Qty allowed 允许个数</th> </tr> </thead> <tbody> <tr> <td>$0.2 < \Phi \leq 0.5$</td> <td>2</td> </tr> </tbody> </table> Distance between 2 spots $> 5\text{mm}$ 两点间距 $> 5\text{mm}$ Ignore if out of viewing area. 可视区外忽略不计	Size (mm) 尺寸	Qty allowed 允许个数	$0.2 < \Phi \leq 0.5$	2
Size (mm) 尺寸	Qty allowed 允许个数						
$0.2 < \Phi \leq 0.5$	2						
Electrode & pin Nonconformity 电极与PIN脚不良	Pin Length PIN 长		Non-conformity with engineering drawing REJ 拒收 与工程图不符	MA			
	Pin Deflection PIN 歪斜		Deviation exceeds 5 degree REJ 拒收 偏差 $> 5^\circ$ According to the tolerance specified in engineering drawing 若工程图有规定范围, 则依图面规格	MI			
	Pin body With resin PIN 上有胶		REJ 拒收	MI			
	Deflection Frame Lines 切斜		Deviation between two ends exceeds 0.25mm REJ 拒收 两端相差 0.25mm	MI			

Contact Pad Unclean 导电层不洁		REJ 拒收	MI
Silk Printing Nonconformity 表面丝印不良		1、 Unspecified tolerance of width of line $\leq 1/4$ width. ACC 线宽均匀性 $\leq 1/4$ 线宽 接收 2、 Silk printing location: According to the Tolerance specified in engineering drawing 丝印位置依工程图要求的公差 3、 Diameter of broken pattern $\leq 0.25\text{mm}$. ACC 缺失图案直径 $\leq 0.25\text{mm}$. 接收	MI

5.5 Inspection Quality Criteria

ITME	DESCRIPTION OF DEFECTS			Class of defects	Acceptable level (%)
FUNCTION	Short circuit or Pattern cut			Major	0.65
DIMENSION	Refer to individual acceptance specification			Major	2.5
BLACK SPOTS	Ave. Dia. D	area A	area B	Minor	2.5
	$D \leq 0.2$	Disregard			
	$0.2 < D \leq 0.3$	2	3		
	$0.3 < D \leq 0.4$	0	1		
	$0.4 < D$	0	0		
BLACK LINES	Width W, Length L	A	B	Minor	2.5
	$W \leq 0.03$	disregard			
	$0.03 < W \leq 0.05$	3	4		
	$0.05 < W \leq 0.07, L \leq 3.0$	1	1		
BUBBLES IN POLARIZER	Average diameter D $0.2 < D < 0.5\text{mm}$ for N = 4 $0.5 < D < 0.7\text{mm}$ for N=1			Minor	2.5
COLOR UNIFORMITY	Rainbow color or Newton ring.			Minor	2.5
GLASS SCRATCHES	Obvious visible damage.			Minor	2.5
VIEWING ANGLE	Refer to individual acceptance specification			Minor	2.5
CONTRAST RATIO	Refer to individual acceptance specification			Minor	2.5
RESPONSE TIME	Refer to individual acceptance specification			Minor	2.5

5.6 Reliability

The LCD module should have no failure in the following reliability test.

TEST ITEM	TEST CONDITIONS
HIGH TEMPERATURE STORAGE	80°C, 200hr.
LOW TEMPERATURE STORAGE	-30°C, 200hr
HUMIDITY STORAGE	80°C, 90%RH, 96hr.
HIGH TEMPERATURE OPERATION	70°C, typical operating conditions, 200hr.
LOW TEMPERATURE OPERATION	-20°C, typical operating conditions, 200hr.
TEMPERATURE CYCLING	-20 °C ~70 °C 10min, between each step temp. 50min, at each step temp. 5 cycles.
MECHANICAL VIBRATION	10 ~ 100 Hz sweep, 4G, amp1 = 10mm(max) XYZ for 60min, each.
MECHANICAL SHOCK	10 ~ 55Hz, 50G. XYZ for 1 time, each.

NOTE 1: The module should not have condensation of water on the module.

NOTE 2: The module should be inspected after 1 hour storage in normal conditions (15~35 °C, 45~65%RH).

6. PACKING

6.1 Packing Materials

No.	ITEM	DIMENSION (L*W*H)
1	Anti-static bag	90*50
2	Foam box	365*350*55
3	Carton	405*385*255

7. CAUTION FOR USING LCM

7.1 Precautions in handling LCD Modules

Lcms have been assembled and accurately calibrated before delivery.

Please observe the following criteria when handling.

- A. Do not subject the module to excessive shock.
- B. Do not modify the tab on the metal holder.
- C. Do not tamper with the printed circuit board.
- D. Limit the soldering of the printed circuit board to I/O terminals only.

Do not touch the zebra strip nor modify its location.

7.2 Static electricity warning

LCM uses CMOS LSI technology. Therefore, strict measures to avoid static electricity discharge are followed through all processes from manufacturing to shipping. When handling a LCM, take sufficient care to prevent static electricity discharge as you would any CMOS IC.

- A. Do not take the LCM from its anti-static bag until it's to be assembled.

LCMs are individually packaged in bags specially treated to resist static electricity. When storing, keep the LCM packed in the original bags, or store them in a container processed to be resistant to static electricity, or in an electric conductive container.

- B. Always use a ground strap when handling a LCM.

Always use a ground strap while working with the module, from the time it is taken out of the anti-static bag until it is assembled. If it is necessary to transfer the LCM, once it has been taken out of the bag, always place it in an electric conductive container. Avoid wearing clothes made of chemical fibers, the use of cotton or conductive treated fiber clothing is recommended.

- C. Use a no-leak iron for soldering the LCM.

The soldering iron to be used for soldering the I/O terminals to the LCM are to be insulated or grounded at the iron tip.

D. Always ground electrical apparatuses required for assembly.

Electrical apparatuses required to assemble the LCM into a product, i.e. electrical screw drivers, are to be first grounded to avoid transmitting spike noises from the motor.

E. Assure that the work bench is properly grounded.

F: Peel off the LCM protective film slowly.

The module is attached with a film to protect the display surface from contamination, damage, adhesion of flux, etc. Peeling off this film abruptly could cause static electricity to be generated, so peel the tape slowly.

G: Pay attention to the humidity in the work area. 50~60% RH is recommended.

7.3 Storage

If the correct method of storage is not followed, deterioration of the display material (polarizer) and oxidation of the I/O terminal plating may make the process of soldering difficult. Please comply with the following procedure.

A. Store in the shipping container.

B. If the shipping container is not available, place in anti-static bags and seal the opening.

C. Store the modules where they are not subjected to direct sunlight or a fluorescent lamp.

D. Store in a temperature range of 0°C – 35°C with low relative humidity.

7.4 Caution

A. Do not give any external shock.

B. Do not wipe the surface with hard materials.

C. Do not apply excessive force on the surface.

D. Do not expose to direct sunlight or fluorescent light for a long time.

E. Avoid storage in high temperature and high humidity.

F. When storage for a long time at 40°C or higher is required, R/H should be less than 60%.

Liquid in LCD is hazardous substance. Do not lick, swallow when the liquid is attached to your hands, skin, clothes etc. Wash it out thoroughly.