

HTM24064A

LCD Module User Manual

Shenzhen HOT Display Technology Co., Ltd.

Rev.	Descriptions	Date
01	Prelimiay Release	2007-12-25

Table of Content

1. Display Specification	3
2. Mechanical Specifications	3
2.1 Outline Dimensions.....	3
3. Circuit Block Diagram	4
4. Absolute Maximum Ratings	4
5. Electrical Specifications and Instruction Code	4
5.1 Electrical Characteristics.....	4
5.2 Interface Signals.....	5
5.3 Interface Timing Chart.....	6
5.4 Instruction Code.....	7
5.5 Character Code Map.....	8
6. Optical Characteristics	8
6.1 Optical Characteristics.....	8
6.2 Definition of optical characteristics.....	8
7. Reliability	10
7.1 Content of Reliability Test.....	10
7.2 Failure Judgment Criterion.....	10
8. Handling Precautions	11
8.1 Mounting method.....	11
8.2 Cautions of LCD handling and cleaning.....	11
8.3 Caution against static charge.....	11
8.4 Packaging.....	11
8.5 Caution for operation.....	11
8.6 Storage.....	11
8.7 Safety.....	11

1. Display Specification

- 1.1 Display type: STN
- 1.2 Display color
 - Display color: Blue
 - Background color: White
- 1.3 Polarizer mode: Negative , Transmissive
- 1.4 Viewing Angle: 6:00
- 1.5 Driving Duty: 1/64
- 1.6 Backlight: LED
 - Color tone is slightly changed by temperature and driving voltage.

2. Mechanical Specifications

2.1 Outline Dimensions(See attached Outline Drawing for Details)

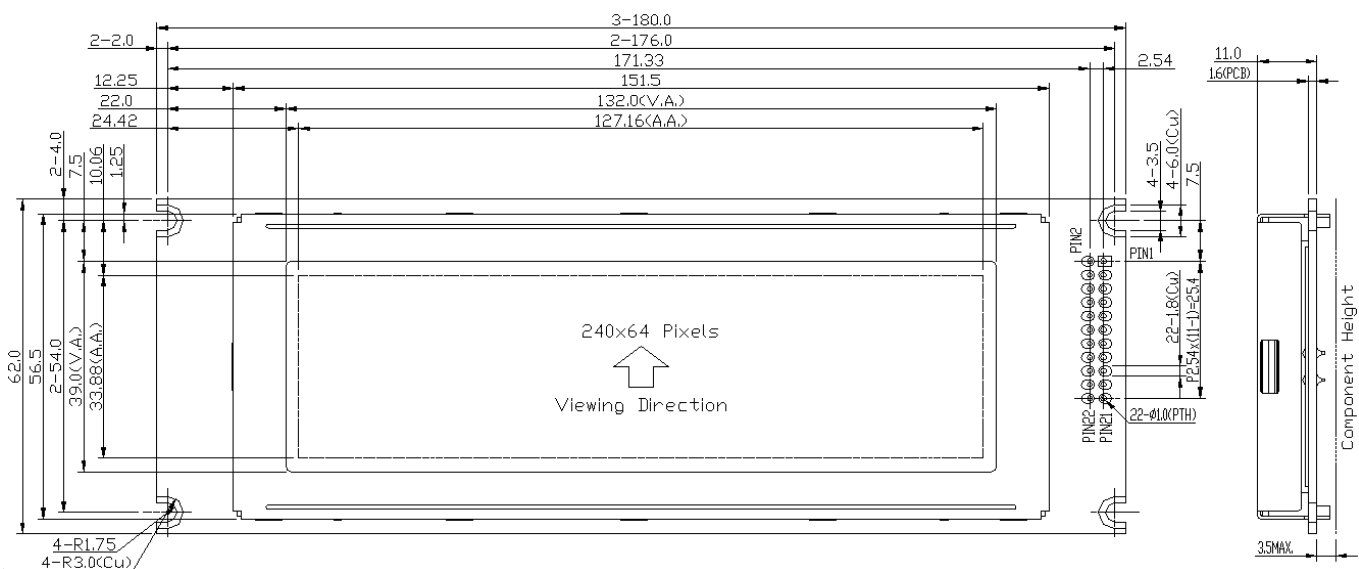

2.2 Dot Matrix: 240 × 64

2.3 Dot size: 0.49×0.49(mm)

2.4 Dot pitch: 0.53×0.53(mm)

3. Circuit Block Diagram

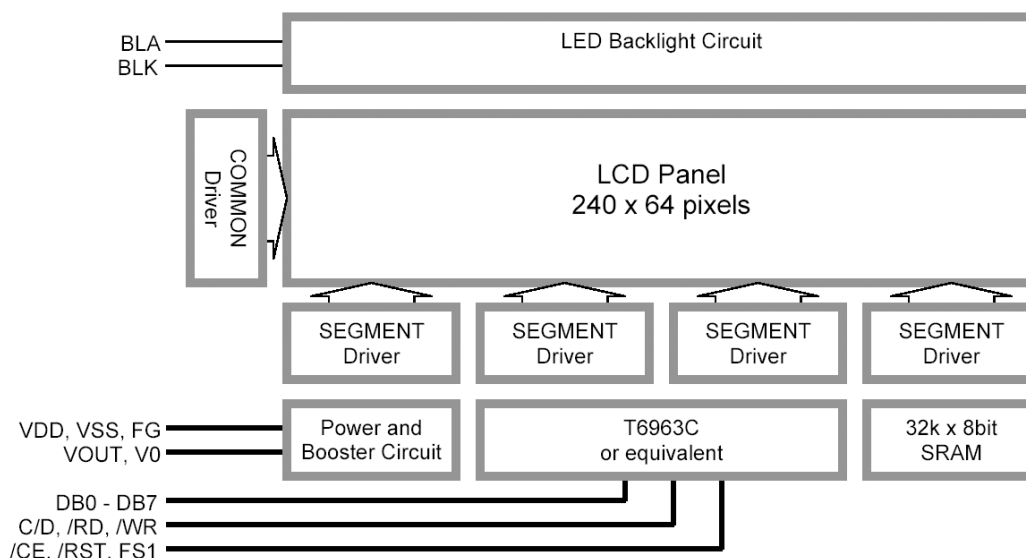

4. Absolute Maximum Ratings

Item	Symbol	Min.	Max.	Unit	Remark
Power Supply Voltage	VDD-VSS	0	6.0	V	
LCD Driving Voltage	VDD-VEE	---	11.3		
Operating Temperature Range	Top	-20	70	°C	NO Condensation
Storage Temperature Range	Tst	-30	80		

5 Electrical Specifications and Instruction Code

5.1 Electrical Characteristics

Item	Symbol	Min.	Typ.	Max.	Unit	Remark
Supply Voltage(logic)	VDD-VSS	4.7	5.0	5.3	V	
Supply Voltage(LCD Drive)	VSS-VEE	---	6.0	---	V	
Input Signal Voltage	"H" Level	VIN	0.7V _{DD}	---	VDD	V
	"L" Level	VIL	V _{SS}	---	0.3V _{DD}	V
Supply current(logic)	IDD	---	10	15	mA	
Supply current (LCD Drive)	IEE	---	2.0	---	mA	
Forward Current	I _f BL	---	90	120	mA	

5.2 Interface Signals

No.	Symbol	Description(Function)	Remark
1	FG	Frame Ground	
2	VSS	Negative Power Supply, (0V)	
3	VDD	Positive Power Supply	
4	V0	Power Supply For LCD	variable
5	/WR	Write Signal	
6	/RD	Read Signal	
7	/CE	Chip Enable	
8	C/D	Command / Data Selection	
9	NC	No connection	
10	/RES	Reset Signal	
11	DB0	Data bit 0	
12	DB1	Data bit 1	
13	DB2	Data bit 2	
14	DB3	Data bit 3	
15	DB4	Data bit 4	
16	DB5	Data bit 5	
17	DB6	Data bit 6	
18	DB7	Data bit 7	
19	FS1	Font Selection	
20	VOUT	Negative voltage output for LCD	
21	BLA	Backlight Power Supply Anode	
22	BLK	Backlight Power Supply Cathode	

5.3 Interface Timing Chart:

Unless otherwise specified, $V_{DD}=5.0\pm 10\%$, $V_{SS}=0V$, $T_a=-10\sim 70^\circ C$

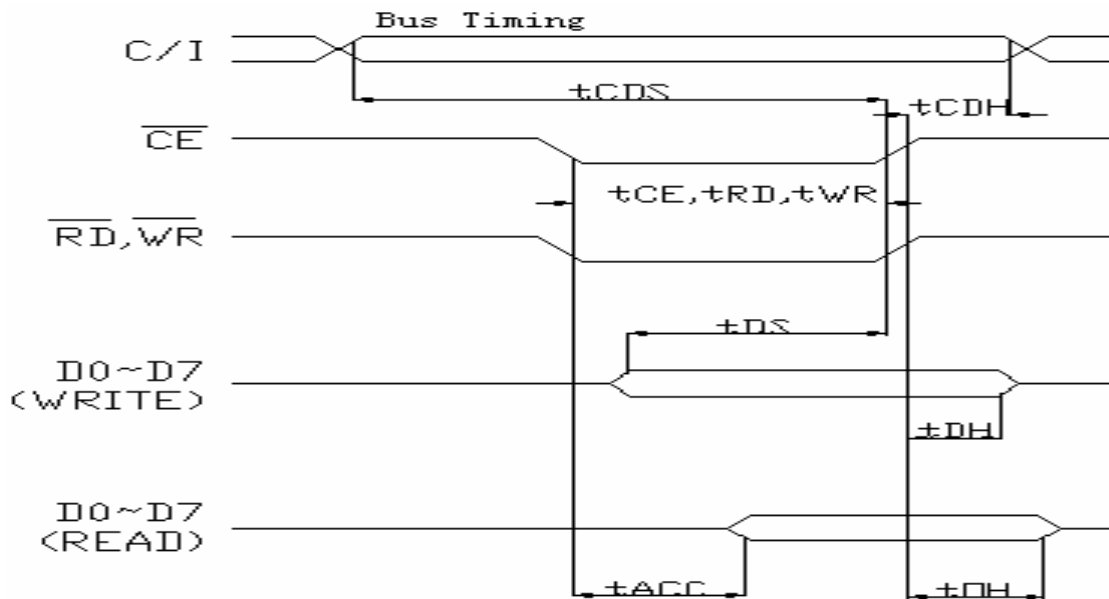

Item	Symbol	Test Condition	MIN	MAX	UNIT
C/D Set up Time	t_{CDS}	--	100	--	ns
C/D Hold Time	t_{CDH}	--	10	--	ns
CE, RD, WR Width	t_{CE}, t_{RD}, t_{WR}	--	80	--	ns
Data Set up Time	t_{DS}	--	80	--	ns
Data Hold Time	t_{DH}	--	40	--	ns
Access Time	t_{ACC}	--	--	150	ns
Output Hold Time	t_{OH}	--	10	50	ns

5.4 Instruction Code

COMMAND	CODE	D1	D2	FUNCTION
REGISTERS	00100001 00100010	X address Data	Y address 00H	Set Cursor Pointer Set Offset Register
SETTING	00100100	Low address	High address	Set Address Pointer
SET CONONTROL WORD	01000000 01000001 01000010 01000011	Low address Columns Low address Columns	High address 00H High address 00H	Set Text Home Address Set Text Area Set Graphic Home Address Set Graphic Area
MODE SET	1000x000 1000x001 1000x011 1000x100 10000xxx 10001xxx	-- -- -- -- -- --	-- -- -- -- -- --	OR mode EXOR mode AND mode Text Attribute mode Internal CG ROM mode External CG RAM mode
DISPLAY MODE	10010000 1001xx10 1001xx11 100101xx 100110xx 100111xx	-- -- -- -- -- --	-- -- -- -- -- --	Display off Cursor on, blink off Cursor on, blink on Text on, graphic off Text off, graphic on Text on , graphic on
CURSOR PATTERN ELECT	10100000 10100001 10100010 10100011 10100100 10100101 10100110 10100111	-- -- -- -- -- -- -- --	-- -- -- -- -- -- -- --	1-line cursor 2-line cursor 3-line cursor 4-line cursor 5-line cursor 6-line cursor 7-line cursor 8-line cursor
DATA AUTO READ/WRITE	10110000 10110001 10110010	-- -- --	-- -- --	Set Data Auto Write Set Data Auto Read Auto Reset
DATA READ/WRITE	11000000 11000001 11000010 11000011 11000100 11000101	-- -- -- -- -- --	-- -- -- -- -- --	Data Write and Increment Data Read and Increment Data Write and Decrement Data Read and Decrement Data Write and Non variable Data Read and Non variable
SCREEN PEEK	11100000	--	--	Screen Peek
SCREEN COPY	11101000	--	--	Screen Copy
BIT SET/RESET	11110xxx 11111xxx 1111x000 1111x001 1111x010 1111x011 1111x100 1111x101 1111x110 1111x111	-- -- -- -- -- -- -- -- -- --	-- -- -- -- -- -- -- -- -- --	Bit reset Bit set Bit0 (LSB) Bit1 Bit2 Bit3 Bit4 Bit5 Bit6 Bit7 (MSB)

5.5 Character Code Map

LSB MSB	0	1	2	3	4	5	6	7	8	9	A	B	C	D	E	F
0	!	"	#	\$	%	&	'	()	*	+	,	-	.	/	
1	0	1	2	3	4	5	6	7	8	9	:	;	<	=	>	?
2	P	A	B	C	D	E	F	G	H	I	J	K	L	M	N	O
3	P	Q	R	S	T	U	U	W	X	Y	Z	[\]	^	_
4	'	a	b	c	d	e	f	g	h	i	j	k	l	m	n	o
5	P	q	r	s	t	u	v	w	x	y	z	{		}	~	0
6	5	0	1	2	3	4	5	6	7	8	9	0	1	2	3	4
7	E	x	R	8	8	8	8	0	0	9	0	0	0	0	0	0

6. Optical Characteristics

6.1 Optical Characteristics Ta=25°C

Item	Symbol	Condition	Min.	Typ.	Max.	Unit	Remark	
Viewing angle	θ_x	$Cr > 3$	$\theta_y = 0$	-20	----	20	deg	
	θ_y			$\theta_x = 0$	-25	----		
Contrast Ratio	Cr	$\theta_x = 0^\circ \theta_y = 15^\circ$	3	--	--			
Response Time	Turn on	Ton	$\theta_x = 0^\circ$	--	--	200	ms	
	Turn off	Toff	$\theta_y = 0^\circ$	--	--	360		

6.2 Definition of optical characteristics

6.2.1 Definition of viewing Angle(see fig.as follow)

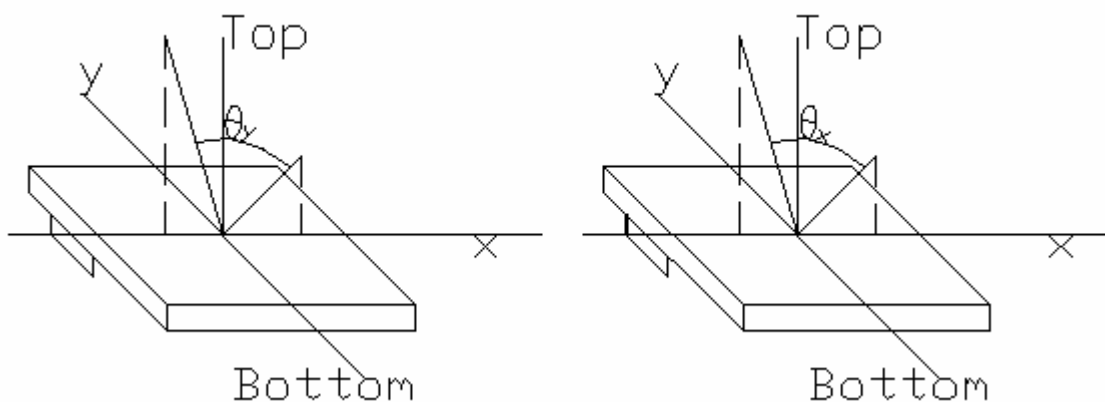

6.2.2 Definition of Contrast Ratio(see fig.as follow)

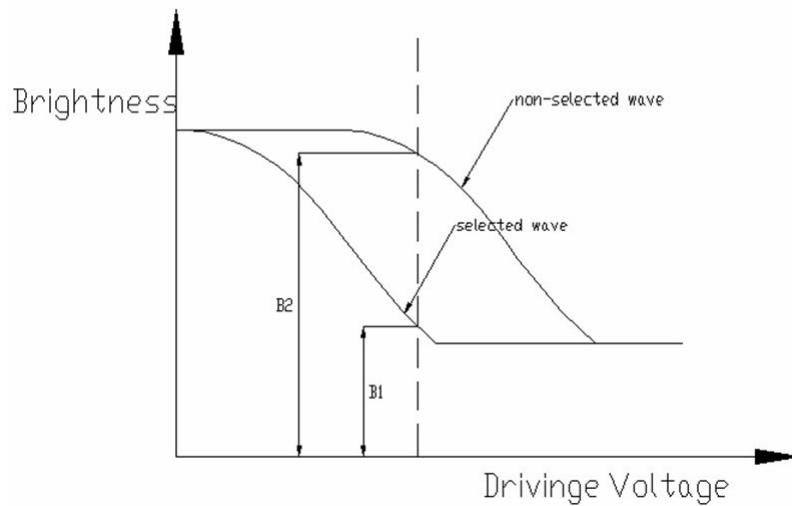

Contrast Ratio(K)= $\frac{B2}{B1}$ _____
 selected state brightness

Measuring Conditions:

- 1) Ambient Temperature: 25°C;
- 2) Frame frequency : 32Hz

6.2.3 Definition of Response time (see fig.as follow)

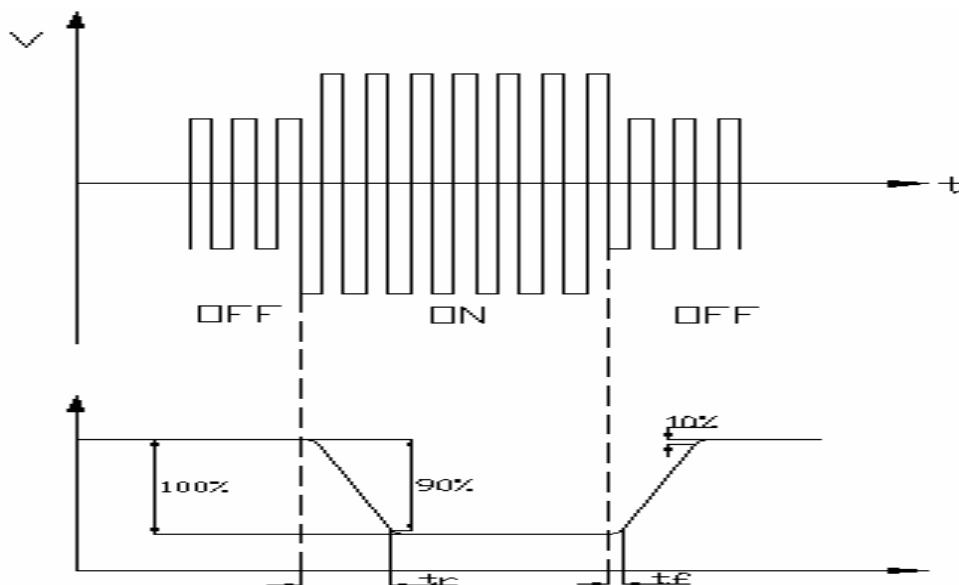

7. Reliability

7.1 Content of Reliability Test

No.	Test Item	Content of Test	Test condition
1	High Temperature Storage	Endurance test applying the high storage temperature for a long time	60℃, 96H
2	Low Temperature Storage	Endurance test applying the low storage temperature for a long time	50℃, 96H
3	High Temperature Operation	Endurance test applying the Temperature electric stress (voltage¤t) and the thermal stress to the element for a long time	50℃, 96H
4	High Temperature Operation	Endurance test applying the Temperature electric stress (voltage¤t) and the thermal stress to the element for a long time	0℃, 96H
5	High Temperature/Humidity Storage	Endurance test applying the high temperature and high humidity storage for a long time	40℃, 96H 90%RH
6	Temperature Cycle	Endurance test applying the low and high temperature cycle 10 cycle -20℃--25℃--60℃--25℃ 30min 5min 30min 5min 1cycle	-20℃/60℃
7	Vibration Test(package state)	Endurance test applying the vibration during transportation	10Hz~55Hz~10Hz 1.5mmP-P,1.5gX.Y.-5mm
8	Shock Test(package state)	Endurance test applying the shock during transportation	Drop a product form a height of 79cm to a solid unbending and horizontal plane
9	Atmospheric Pressure Test	Endurance test applying the atmospheric prssure during transportation by air	40kPa,24H

7.2 Failure Judgment Criterion

Criterion	Test Item No.	Failure Judgement
Item		Criterion
Basic Specification		Out of the basic Specification
Electrical Specification		Out of the electrical specification
Mechanical Specification		Out of the mechanical specification
Optical Characteristic		Out of the optical specification
Remark	Basic specification = Display specification + Mechanical specification	

8. Handling Precautions

8.1 Mounting method

A panel of LCD module made by our company consists of two thin glass plates with polarizers that easily get damaged. And since the module is so constructed as to be fixed by utilizing fitting holes in the printed circuit board (PCB), extreme care should be used when handling the LCD modules.

8.2 Cautions of LCD handling and cleaning

When cleaning the display surface, use soft cloth with solvent (recommended below) and wipe lightly.

- Isopropyl alcohol
- Ethyl alcohol
- Trichlorotrifluoroethane

Do not wipe the display surface with dry or hard materials that will damage the polarizer surface.

Do not use the following solvent:

- Water
- Ketene
- Aromatics

8.3 Caution against static charge

The LCD module uses C-MOS LSI drivers. So we recommend you:

Connect any unused input terminal to V_{dd} or V_{ss} . Do not input any signals before power is turned on, and ground your body, work/assembly areas, assembly equipment to protect against static electricity.

8.4 Packaging

- Module employs LCD elements, and must be treated as such. Avoid intense shock and falls from a height.
- To prevent modules from degradation, do not operate or store them exposed direct to sunshine or high temperature/humidity.

8.5 Caution for operation

-It is an indispensable condition to drive LCD module within the limits of the specified voltage since the higher voltage over the limits may cause the shorter life of LCD module.

-An electrochemical reaction due to DC (direct current) causes LCD undesirable deterioration so that the uses of DC (direct current) drive should be avoided.

-Response time will be extremely delayed at lower temperature than the operating temperature range and on the other hand at higher temperature LCD module may show dark color in them. However those phenomena do not mean malfunction or out of order of LCD module, which will come back in the specified operating temperature.

8.6 Storage

In the case of storing for a long period of time, the following ways are recommended:

- Storage in polyethylene bag with the opening sealed so as not to enter fresh air outside in it. And with not desiccant.
- Placing in a dark place where neither exposure to direct sunlight nor light is. Keeping the storage temperature range.
- Storing with no touch on polarizer surface by any thing else.

8.7 Safety

-It is recommendable to crash damaged or unnecessary LCD into pieces and to wash off liquid crystal by either of solvents such as acetone and ethanol, which should be burned up later.

-When any liquid leaked out of a damaged glass cell comes in contact with your hands, please wash it off well at once with soap and water.