



MULTI-INNO TECHNOLOGY CO., LTD.

www.multi-inno.com

LCD MODULE SPECIFICATION

Model : MI0700J1T

This module uses ROHS material

For Customer's Acceptance:

Customer	
Approved	
Comment	

This specification may change without prior notice in order to improve performance or quality. Please contact Multi-Inno for updated specification and product status before design for this product or release of this order.

Revision	3.3
Engineering	
Date	2013-09-24
Our Reference	

**REVISION RECORD**

REV NO.	REV DATE	CONTENTS	REMARKS
1.0	2009-11-20	First Release	
2.0	2009-12-19	Change surface luminance	
3.0	2010-01-05	Modify touch panel characteristics	
3.1	2013-04-24	Change surface luminance Change LED dice life time	
3.2	2013-07-29	Change operating temperature and storage temperature	
3.3	2013-09-24	Update Inspection Criterion	

CONTENTS

- GENERAL INFORMATION
- EXTERNAL DIMENSIONS
- ABSOLUTE MAXIMUM RATINGS
- ELECTRICAL CHARACTERISTICS
- ELECTRO-OPTICAL CHARACTERISTICS
- INTERFACE DESCRIPTION
- BLOCK DIAGRAM
- APPLICATION NOTES
- TOUCH PANEL CHARACTERISTICS
- RELIABILITY TEST
- INSPECTION CRITERION
- PRECAUTIONS FOR USING LCD MODULES
- PRIOR CONSULT MATTER

■ GENERAL INFORMATION

Item	Contents	Unit
LCD type	TFT/Normally white	/
Size	7.0	Inch
Viewingdirection	12:00	O' Clock
Gray scale inversion direction	6:00	O'Clock
LCM (W × H × D)	165.00×104.44×11.06	mm ³
Active area (W×H)	152.40×91.44	mm ²
Dot pitch (W×H)	0.0635×0.1905	mm ²
Number of dots	800 (RGB) × 480	/
Backlight type	24 LEDs	/
Interface type	LVDS	/
Color depth	262K	/
Pixel configuration	Stripe	/
Surface treatment	Anti-glare and hard coating(3H)	/
Input voltage	3.3	V
With/Without TSP	With TSP	/
Weight	TBD	g

Note 1:Viewing direction for best image quality is different from TFT definition, there is a 180 degree shift.

Note 2 : RoHS compliant;

Note 3: LCM weight tolerance: ± 5% .

EXTERNAL DIMENSIONS

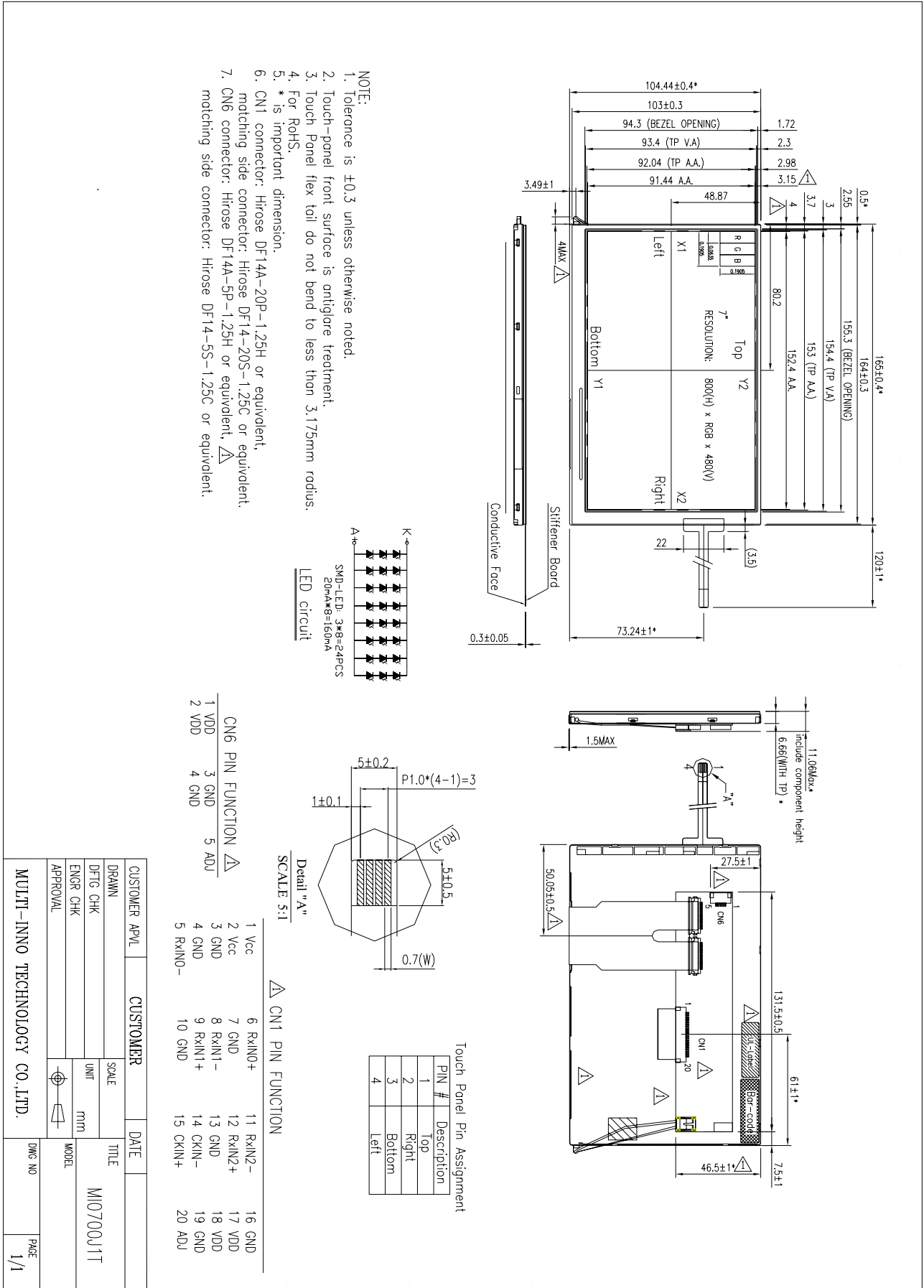

■ABSOLUTE MAXIMUM RATINGS

Parameter		Symbol	Min	Max	Unit
Power supply voltage		VCC	-0.3	6.0	V
Logic input voltage		VI	-0.3	VCC+0.3	V
Operating temperature		T _{OP}	-20	70	°C
Storage temperature		T _{ST}	-30	80	°C
Humidity	Operation	20%~90% relative humidity (Typ 38°C)			RH
	Non operation	5%~90% relative humidity (Typ 38°C)			

■ELECTRICAL CHARACTERISTICS

DC CHARACTERISTICS

Parameter	Symbol	Min	Typ	Max	Unit
Power supply voltage for LCD	VCC	3.0	3.3	3.6	V
Power supply current for LCD	ICC	-	150	200	mA
Power supply voltage for LED	VDD	3.0	3.3	5.5	V
Power supply current for LED	IDD	-	650	850	mA
		-	400	550	
Differential input high threshold	V _{TH}	-	-	100	mV
Differential input low threshold	V _{TL}	-100	-	-	mV
Ripple voltage	V _{RF}	-	-	100	mVp-p
ADJ frequency		19K	20K	21K	Hz
ADJ input voltage	V _{IH}	3.0	-	3.3	V
	V _{IL}	0	-	0.3	
LED dice life time		-	40,000	-	Hr

Note 1: LVDS Signal Waveform.

Differential Signal

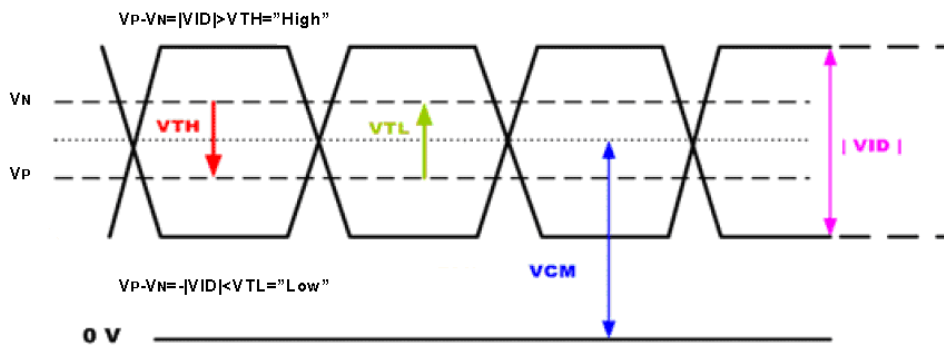

Note 2: The "LED dice life time" is defined as the brightness decrease to 50% original brightness that the ambient temperature is 18°C~28°C and LED dice current=20mA.

Note3: The LED Dice's Ambient Temp. vs. Allowable Forward Current Curve.

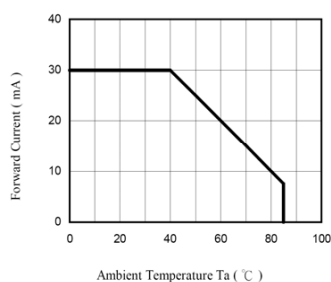

■ELECTRO-OPTICAL CHARACTERISTICS

Item	Symbol	Condition	Min	Typ	Max	Unit	Remark	Note	
Response time	Tr+Tf	$\theta=0^\circ$ $\varnothing=0^\circ$ $T_a=25^\circ\text{C}$	-	16	26	ms	FIG 1.	4	
Contrast ratio	Cr		250	400	-	---	FIG 2.	1	
Luminance uniformity	δ WHITE		70	80	-	%	FIG 2.	3	
Surface Luminance	Lv		-	400	-	cd/m ²	FIG 2.	2	
Viewing angle range	θ	$\varnothing = 90^\circ$	55	60	-	deg	FIG 3.	6	
		$\varnothing = 270^\circ$	55	60	-	deg	FIG 3.		
		$\varnothing = 0^\circ$	65	70	-	deg	FIG 3.		
		$\varnothing = 180^\circ$	65	70	-	deg	FIG 3.		
CIE (x, y) chromaticity	Red	x	-	-	-	FIG 2.	5		
		y	-	-	-				
	Green	x	-	-	-				
		y	-	-	-				
	Blue	x	-	-	-				
		y	-	-	-				
	White	x	0.26	0.31	0.36				
		y	0.28	0.33	0.38				
Image sticking	-	tis	2 hours	-	-	2	Sec	-	8

Note 1. Contrast Ratio(CR) is defined mathematically as For more information see FIG 2.

$$\text{Contrast Ratio} = \frac{\text{Average Surface Luminance with all white pixels (P1, P2, P3, P4, P5)}}{\text{Average Surface Luminance with all black pixels (P1, P2, P3, P4, P5)}}$$

Note 2. Surface luminance is the LCD surface from the surface with all pixels displaying white. For more information see FIG 2.

$$L_v = \text{Average Surface Luminance with all white pixels (P1, P2, P3, P4, P5)}$$

Note 3. The uniformity in surface luminance , δ WHITE is determined by measuring luminance at each test position 1 through 5, and then dividing the maximum luminance of 5 points luminance by minimum luminance of 5 points luminance. For more information see FIG 2.

$$\delta \text{ WHITE} = \frac{\text{Minimum Surface Luminance with all white pixels (P1, P2, P3, P4, P5)}}{\text{Maximum Surface Luminance with all white pixels (P1, P2, P3, P4, P5)}}$$

Note 4. Response time is the time required for the display to transition from White to black(Rise Time, Tr) and from black to white(Decay Time, Tf). For additional information see FIG 1. The test equipment is Autronic-Melchers's ConoScope. Series.

Note 5. CIE (x, y) chromaticity, The x, y value is determined by measuring luminance at each test position 1 through 5, and then make average value.

Note 6. Viewing angle is the angle at which the contrast ratio is greater than 2. For TFT module the contrast ratio is greater than 10. The angles are determined for the horizontal or x axis and the vertical or y axis with respect to the z axis which is normal to the LCD surface. For more information see FIG 3.

Note 7. For viewing angle and response time testing, the testing data is base on Autronic-Melchers's ConoScope. Series Instruments For contrast ratio, Surface Luminance, Luminance uniformity, CIE The test data is base on TOPCON's BM-5 photo detector.

Note 8: Definition of Image sticking (tis):

Continuously display the test pattern shown in the figure below for 2 hours. Then display a completely white screen. The previous image shall not persist more than 2 sec at 25 °C

Image sticking pattern

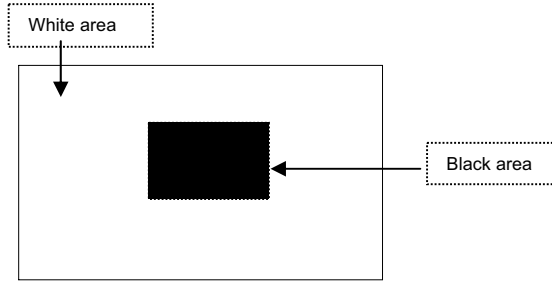

FIG. 1 The definition of Response Time

The response time is defined as the following figure and shall be measured by switching the input signal for “black” and “white”.

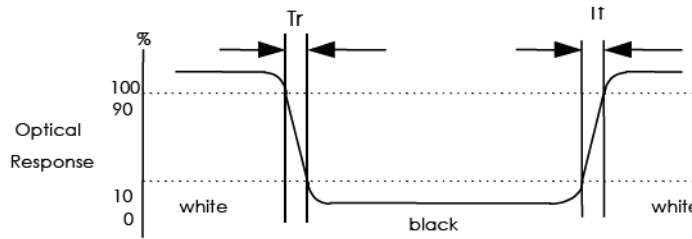

FIG. 2 Measuring method for Contrast ratio, surface luminance, Luminance uniformity , CIE (x, y) chromaticity

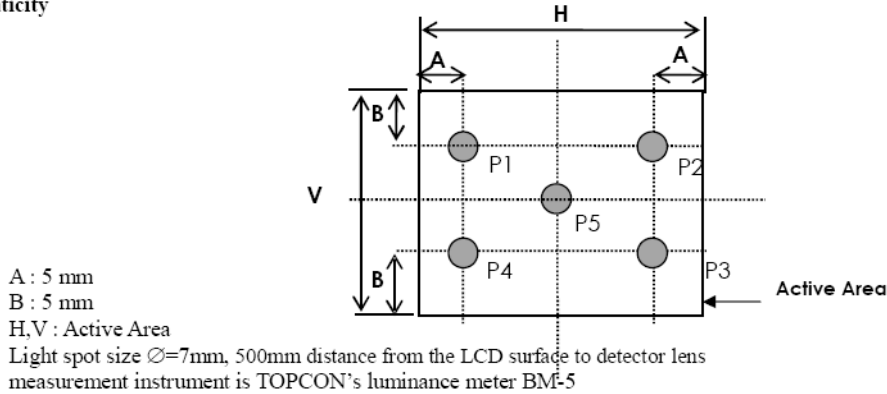
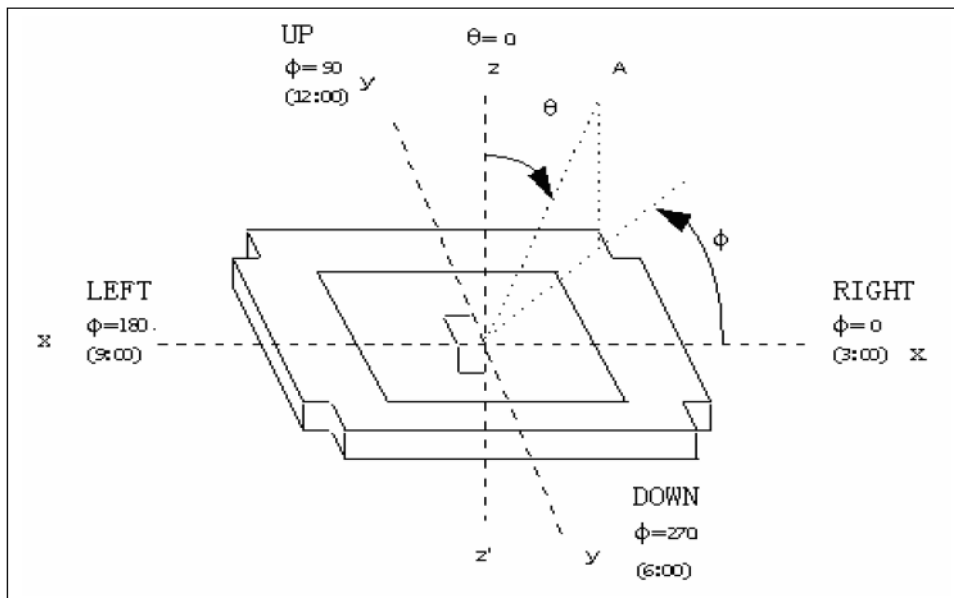

FIG. 3 The definition of viewing angle



■ INTERFACE DESCRIPTION

Pin No	Symbol	Function	Remark
1	VCC	power supply for Digital Circuit	
2	VCC	power supply for Digital Circuit	
3	GND	Ground	
4	GND	Ground	
5	RxIN0-	Differential Data Input ,CH0(Negative)	
6	RxIN0+	Differential Data Input ,CH0(Positive)	
7	GND	Ground	
8	RxIN1-	Differential Data Input ,CH1(Negative)	
9	RxIN1+	Differential Data Input ,CH1(Positive)	
10	GND	Ground	
11	RxIN2-	Differential Data Input ,CH2(Negative)	
12	RxIN2+	Differential Data Input ,CH2(Positive)	
13	GND	Ground	
14	CKIN-	Differential Clock Input (Negative)	
15	CKIN+	Differential Clock Input (Positive)	
16	GND	Ground	
17	VDD	Power Supply for LED Driver Circuit	
18	VDD	Power Supply for LED Driver Circuit	
19	GND	Ground	
20	ADJ	Brightness control for LED B/L	

Remarks :

- 1) ADJ is brightness control Pin. The larger of the pulse duty is, the higher of the brightness.
- 2) ADJ signal is 0~3.3V.Operation frequency is 20KHz
- 3) GND PIN must be grounding, can not be floating.

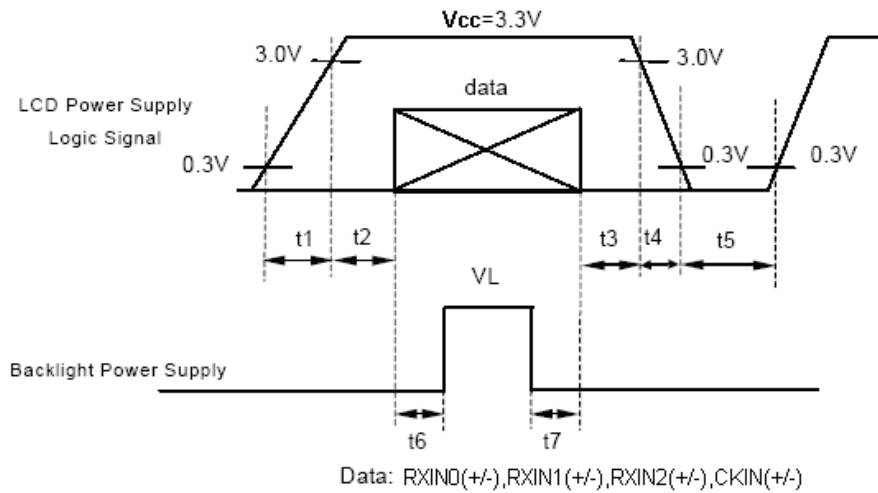
Remarks:
Power Signal sequence:
 $t1 \leq 10\text{ms}$; $1 \text{ sec} \leq t5$
 $50\text{ms} \leq t2$; $200\text{ms} \leq t6$
 $0 < t3 \leq 50\text{ms}$; $200\text{ms} \leq t7$
 $0 < t4 \leq 10\text{ms}$

VCC-dip condition:

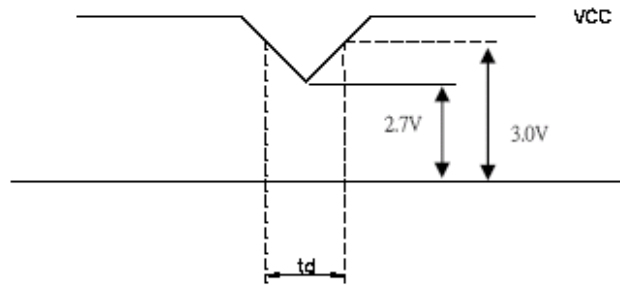
 (1) $2.7 \text{ V} \leq V_{CC} < 3.0\text{V}$, $t_d \leq 10 \text{ ms}$

 (2) $V_{CC} > 3.0\text{V}$, VCC-dip condition should be the same with VCC-turn-on condition.

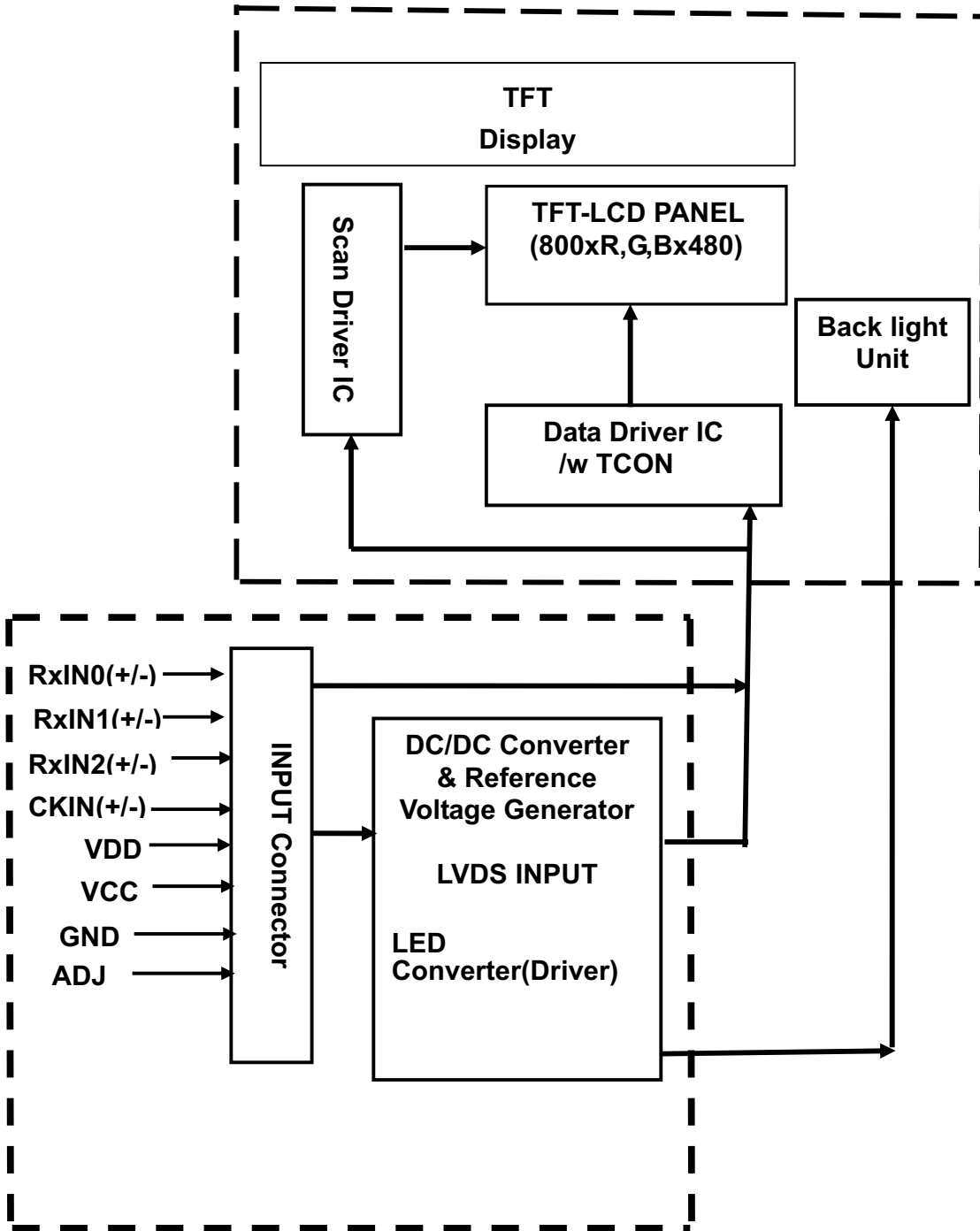
■ BLOCK DIAGRAM



■ APPLICATION NOTES

1. AC Characteristics

1.1 AC Electrical Characteristics

Parameter	Symbol	MIN.	TYP.	MAX.	Unit
Data setup time	T_{dsu}	6	-	-	ns
Data hold time	T_{dhd}	6	-	-	ns
DE setup time	T_{esu}	6	-	-	ns

1.2 Resolution : 800x480

Parameter	Symbol	MIN.	TYP.	MAX.	Unit
DCLK frequency	F_{CPH}	25	33.26	40	MHz
DCLK period	T_{CPH}	-	30.06	-	ns
DCLK pulse duty	T_{CWH}	40	50	60	%
DE period	$T_{DEH}+T_{DEL}$	1000	1056	1200	T_{CPH}
DE pulse width	T_{DEH}	-	800	-	T_{CPH}
DE frame blanking	T_{DEB}	10	45	110	$T_{DEH}+T_{DEL}$
DE frame width	T_{DE}	-	480	-	$T_{DEH}+T_{DEL}$

2. Timing Controller Timing Chart

2.1 Clock and Data input waveforms

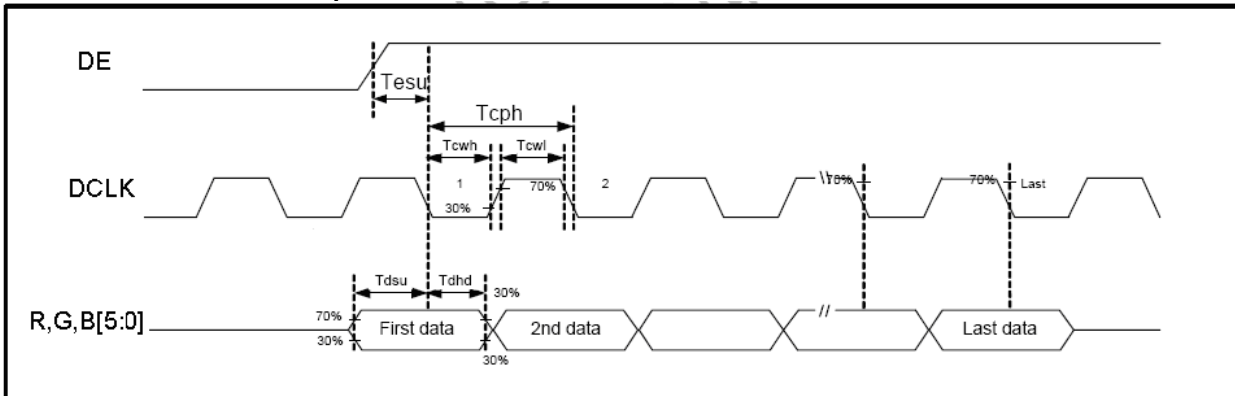
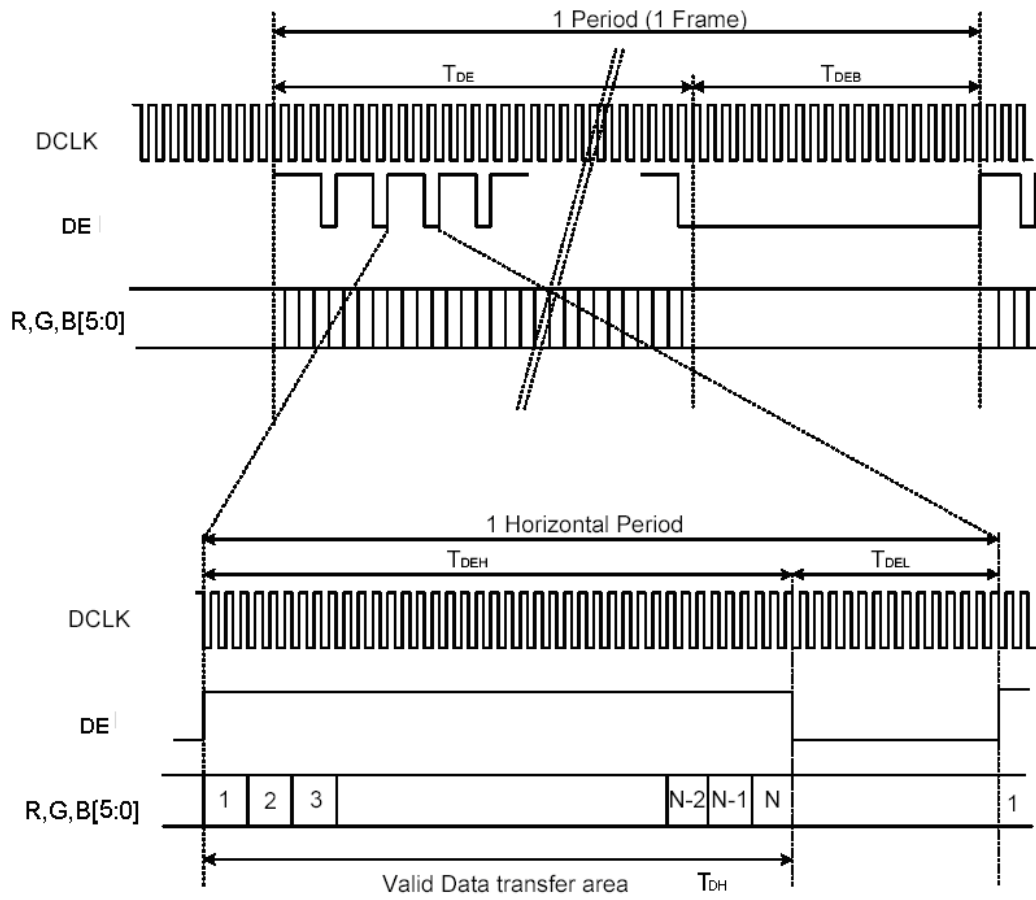
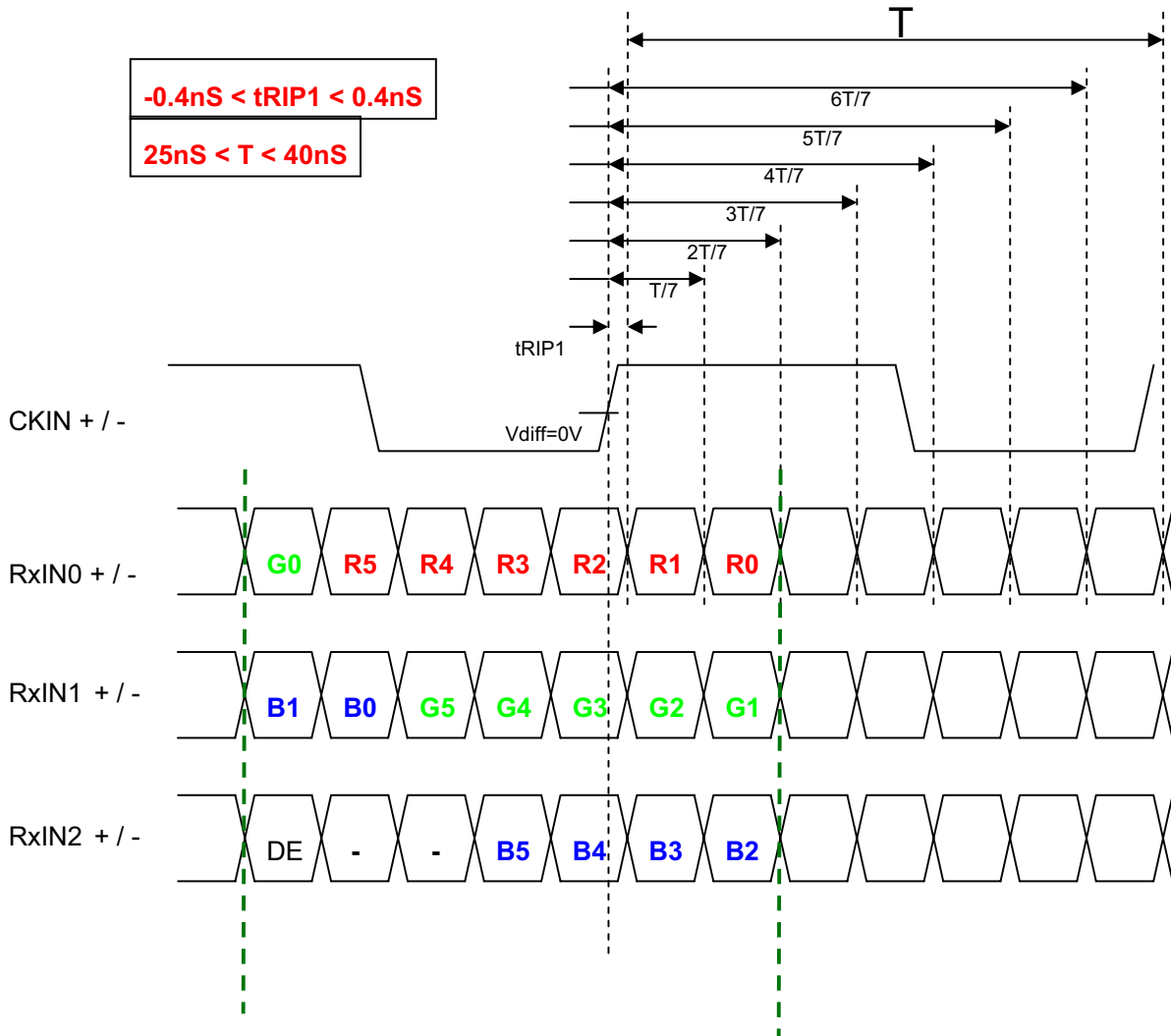

Figure 1 Clock and Data input waveforms.



2.2 LVDS Timing Chart



3. Color Data Input Assignment

		Data Signal																	
		Red						Green						Blue					
Color		R5	R4	R3	R2	R1	R0	G5	G4	G3	G2	G1	G0	B5	B4	B3	B2	B1	B0
Basic Colors	Black	0	0	0	0	0	0	0	0	0	0	0	0	0	0	0	0	0	0
	Red	1	1	1	1	1	1	0	0	0	0	0	0	0	0	0	0	0	0
	Green	0	0	0	0	0	0	1	1	1	1	1	1	0	0	0	0	0	0
	Blue	0	0	0	0	0	0	0	0	0	0	0	0	1	1	1	1	1	1
	Cyan	0	0	0	0	0	0	1	1	1	1	1	1	1	1	1	1	1	1
	Magenta	1	1	1	1	1	1	0	0	0	0	0	0	1	1	1	1	1	1
	Yellow	1	1	1	1	1	1	1	1	1	1	1	1	0	0	0	0	0	0
	White	1	1	1	1	1	1	1	1	1	1	1	1	1	1	1	1	1	1
Gray Scale of Red	Red(0) / Dark	0	0	0	0	0	0	0	0	0	0	0	0	0	0	0	0	0	0
	Red(1)	0	0	0	0	0	1	0	0	0	0	0	0	0	0	0	0	0	0
	Red(2)	0	0	0	0	1	0	0	0	0	0	0	0	0	0	0	0	0	0
	:	:	:	:	:	:	:	:	:	:	:	:	:	:	:	:	:	:	:
	:	:	:	:	:	:	:	:	:	:	:	:	:	:	:	:	:	:	:
	Red(61)	1	1	1	1	0	1	0	0	0	0	0	0	0	0	0	0	0	0
	Red(62)	1	1	1	1	1	0	0	0	0	0	0	0	0	0	0	0	0	0
	Red(63)	1	1	1	1	1	1	0	0	0	0	0	0	0	0	0	0	0	0
Gray Scale of Green	Green(0) / Dark	0	0	0	0	0	0	0	0	0	0	0	0	0	0	0	0	0	0
	Green(1)	0	0	0	0	0	0	0	0	0	0	0	1	0	0	0	0	0	0
	Green(2)	0	0	0	0	0	0	0	0	0	0	1	0	0	0	0	0	0	0
	:	:	:	:	:	:	:	:	:	:	:	:	:	:	:	:	:	:	:
	:	:	:	:	:	:	:	:	:	:	:	:	:	:	:	:	:	:	:
	Green(61)	0	0	0	0	0	0	1	1	1	1	1	0	1	0	0	0	0	0
	Green(62)	0	0	0	0	0	0	1	1	1	1	1	0	0	0	0	0	0	0
	Green(63)	0	0	0	0	0	0	1	1	1	1	1	1	0	0	0	0	0	0
Gray Scale of Blue	Blue(0) / Dark	0	0	0	0	0	0	0	0	0	0	0	0	0	0	0	0	0	0
	Blue (1)	0	0	0	0	0	0	0	0	0	0	0	0	0	0	0	0	0	1
	Blue (2)	0	0	0	0	0	0	0	0	0	0	0	0	0	0	0	0	1	0
	:	:	:	:	:	:	:	:	:	:	:	:	:	:	:	:	:	:	:
	:	:	:	:	:	:	:	:	:	:	:	:	:	:	:	:	:	:	:
	Blue (61)	0	0	0	0	0	0	0	0	0	0	0	0	1	1	1	1	0	1
	Blue (62)	0	0	0	0	0	0	0	0	0	0	0	0	1	1	1	1	1	0
	Blue (63)	0	0	0	0	0	0	0	0	0	0	0	0	1	1	1	1	1	1

Correspondence between Data and Display Position

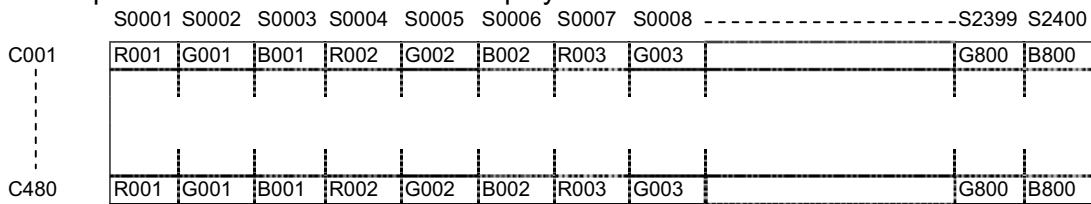

■ TOUCH PANEL CHARACTERISTICS

1. Input Method and Activation Force

Input Method	Activation Force
0.8mm dia. Delrin Polyacetal stylus	60~100gf
8.0mm dia. Silicon "finger"	60~100gf

2. Typical Optical Characteristics

ITEM	Parameter
Visible Light Transmission	≥80%
Haze	<8%
Surface Hardness	>3H

3. Electrical Specification

ITEM	Parameter
Operating Voltage	≤ 10V
Circuit close resistance	X 200~600Ω
	Y 450~1000Ω
Circuit open resistance	>20MΩ at 25V DC
Contact bounce	<10ms
Linear Test	<1.5%

4. Linearity

ITEM	Parameter
Linear Test Specification Direction	X <1.5%
	Y <1.5%

5. Specification

ITEM	Parameter
Operating Temperature	-20°C~+70°C
Storage Temperature	-30°C~+80°C

6. Durability test:

6.1 Touch panel is hit 1 millions times with a silicone rubber of R8 finger, hitting rate is by 250g at 2 times per second. The measurement must satisfy the following:

- Circuit close resistance: x 200~600Ω ;
y 450~1000Ω
- Circuit open resistance: >20MΩ at 25V DC
- Contact bounce: <10ms
- Linearity test: <1.5%

6.2 Stylus writing

Touch panel is drawn by R0.8 Darling stylus pen, at 250g forces, repeat one inch by 100k times. The measurement must satisfy the following:

- Circuit close resistance: x 200~600Ω ;
y 450~1000Ω
- Circuit open resistance: >20MΩ at 25V DC
- Contact bounce: <10ms
- Linearity test: <1.5%

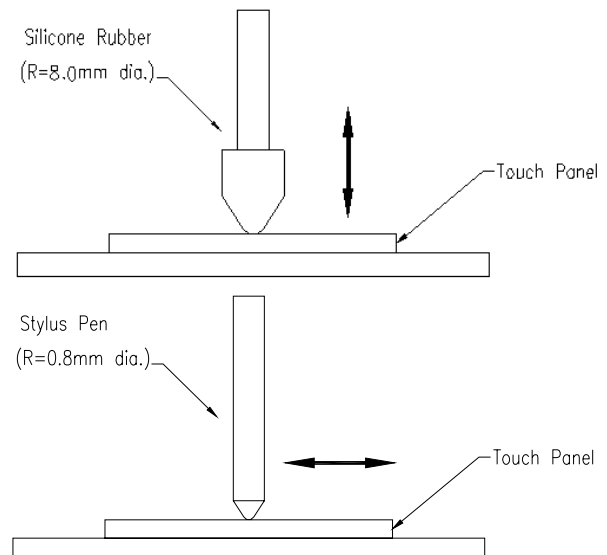

■ RELIABILITY TEST

No.	Test Item	Test Condition
1	High Temperature Storage	$70 \pm 2^{\circ}\text{C}/240$ hours
2	Low Temperature Storage	$-20 \pm 2^{\circ}\text{C}/240$ hours
3	High Temperature Operating	$60 \pm 2^{\circ}\text{C}/240$ hours
4	Low Temperature Operating	$-10 \pm 2^{\circ}\text{C}/240$ hours
5	Temperature Cycle storage	$-20 \pm 2^{\circ}\text{C} \sim 25 \sim 70 \pm 2^{\circ}\text{C} \times 100$ cycles (30min.) (5min.) (30min.)
6	Damp proof Test operating	$40^{\circ}\text{C} \pm 5^{\circ}\text{C} \times 90\% \text{RH}/240$ hours
7	Vibration Test (no-operation)	Frequency: 10~55Hz Amplitude: 1.5mm Sweep time: 11min 6 cycles for each direction of X.Y.Z

INSPECTION CRITERION

	OUTGOING QUALITY STANDARD	PAGE 1 OF 3
--	---------------------------	-------------

TITLE:FUNCTIONAL TEST & INSPECTION CRITERIA

This specification is made to be used as the standard acceptance/rejection criteria for Wider Screen TFT-LCD module product.

1. Sample plan

Sampling plan according to GB/T2828.1-2003/ISO 2859-1 : 1999 and ANSI/ASQC Z1.4-1993, normal level 2 and based on:

Major defect: AQL 0.65

Minor defect: AQL 1.5

2. Inspection condition

1.1 Inspection conditions

1.1.1 Inspection Distance : 35 ± 5 cm

1.1.2 View Angle :

- (1) Inspection under operating condition : $\pm 5^\circ$
- (2) Inspection under non-operating condition : $\pm 45^\circ$

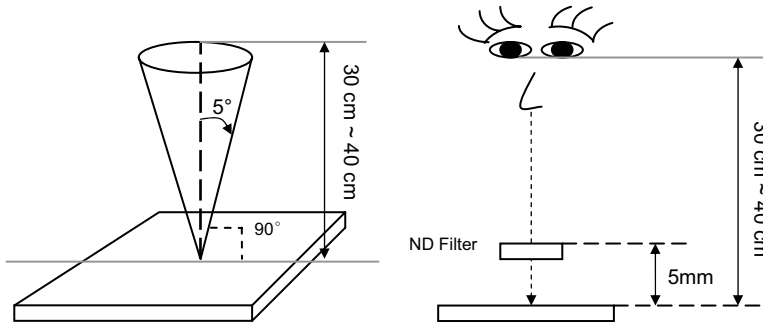



1.1.3 Environment conditions :

Ambient Temperature :		$25 \pm 5^\circ\text{C}$
Ambient Humidity :		$65 \pm 5\%$
Ambient Illumination	Cosmetic Inspection	More than 600lux
	Functional Inspection	300 ~ 800lux

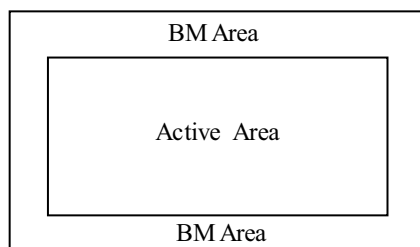
1.2 Definition of applicable Zones

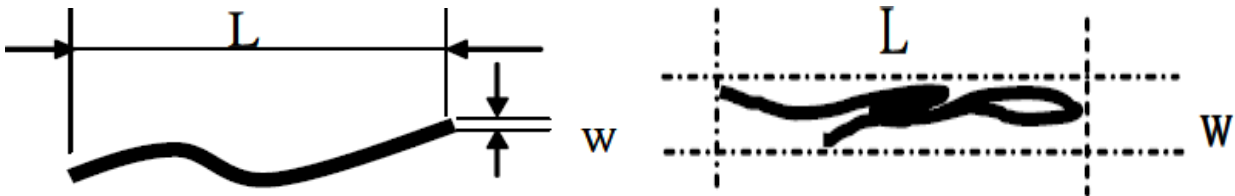
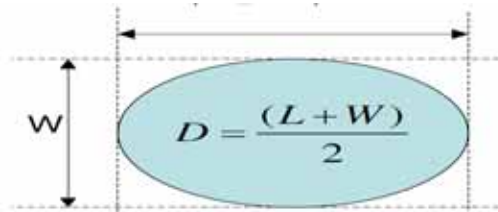

 OUTGOING QUALITY STANDARD		PAGE 2 OF 3																			
TITLE:FUNCTIONAL TEST & INSPECTION CRITERIA																					
3. Inspection parameters																					
1	Operating	Display function: No Display malfunction (Major)																			
		Contrast ratio (Black, White): Does not meet specified range in the spec. (Major) (Note:3)																			
		Line Defect: No obvious Vertical and Horizontal line defect in bright, dark and colored. (Major) (Note:1)																			
		Point Defect (Red, green, blue, dark): Active area ≤ 5 dots (Minor)(Note:1)																			
		<table border="1"> <thead> <tr> <th>Item</th> <th>Acceptable number</th> <th>Total</th> <th>Class Of Defects</th> <th>AQL Level</th> </tr> </thead> <tbody> <tr> <td>Bright</td> <td>3</td> <td rowspan="4">8</td> <td rowspan="4">Minor</td> <td rowspan="4">1.5</td> </tr> <tr> <td>Dark</td> <td>5</td> </tr> <tr> <td>Adjacent Bright</td> <td>1</td> </tr> <tr> <td>Adjacent Dark</td> <td>2</td> </tr> </tbody> </table>				Item	Acceptable number	Total	Class Of Defects	AQL Level	Bright	3	8	Minor	1.5	Dark	5	Adjacent Bright	1	Adjacent Dark	2
		Item	Acceptable number	Total	Class Of Defects	AQL Level															
		Bright	3	8	Minor	1.5															
		Dark	5																		
		Adjacent Bright	1																		
		Adjacent Dark	2																		
Non-uniformity: Visible through 6%ND filter white, RG, B and gray 50%pattern. (Minor)																					
Foreign material in Black or White spots shape ($W > 1/4L$) (Note: 5)																					
<table border="1"> <thead> <tr> <th>Dimension</th> <th>Acceptable number</th> <th>Class Of Defects</th> <th>AQL Level</th> </tr> </thead> <tbody> <tr> <td>$D \leq 0.3$</td> <td>*</td> <td rowspan="3">Minor</td> <td rowspan="3">1.5</td> </tr> <tr> <td>$0.3 < D \leq 0.5$</td> <td>4</td> </tr> <tr> <td>$D > 0.5$</td> <td>0</td> </tr> </tbody> </table>				Dimension	Acceptable number	Class Of Defects	AQL Level	$D \leq 0.3$	*	Minor	1.5	$0.3 < D \leq 0.5$	4	$D > 0.5$	0						
Dimension	Acceptable number	Class Of Defects	AQL Level																		
$D \leq 0.3$	*	Minor	1.5																		
$0.3 < D \leq 0.5$	4																				
$D > 0.5$	0																				
D = (Long + Short) / 2 * : Disregard																					
Foreign Material in Line or spiral shape ($W \leq 1/4L$) (Note: 4)																					
<table border="1"> <thead> <tr> <th>Dimension</th> <th>Acceptable number</th> <th>Class Of Defects</th> <th>AQL Level</th> </tr> </thead> <tbody> <tr> <td>$W > 0.1\text{mm}, L > 5\text{mm}$</td> <td>0</td> <td rowspan="3">Minor</td> <td rowspan="3">1.5</td> </tr> <tr> <td>$L \leq 5\text{mm}, 0.05\text{mm} < W \leq 0.1\text{mm}$</td> <td>4</td> </tr> <tr> <td>$L \leq 5\text{mm}, W < 0.05\text{mm}$</td> <td>*</td> </tr> </tbody> </table>				Dimension	Acceptable number	Class Of Defects	AQL Level	$W > 0.1\text{mm}, L > 5\text{mm}$	0	Minor	1.5	$L \leq 5\text{mm}, 0.05\text{mm} < W \leq 0.1\text{mm}$	4	$L \leq 5\text{mm}, W < 0.05\text{mm}$	*						
Dimension	Acceptable number	Class Of Defects	AQL Level																		
$W > 0.1\text{mm}, L > 5\text{mm}$	0	Minor	1.5																		
$L \leq 5\text{mm}, 0.05\text{mm} < W \leq 0.1\text{mm}$	4																				
$L \leq 5\text{mm}, W < 0.05\text{mm}$	*																				
L : Length W : Width * : Disregard																					
2	External Inspection (non-operating)	Dimension: Outline (Major)																			
		Bezel appearance: uneven (Minor)																			
		Scratch on the polarize & TP: (Note:2)																			
		<table border="1"> <thead> <tr> <th>Dimension</th> <th>Acceptable number</th> <th>Class Of Defects</th> <th>AQL Level</th> </tr> </thead> <tbody> <tr> <td>$W > 0.1\text{mm}, L > 10\text{mm}$</td> <td>0</td> <td rowspan="3">Minor</td> <td rowspan="3">1.5</td> </tr> <tr> <td>$L \leq 10\text{mm}, 0.05\text{mm} < W \leq 0.1\text{mm}$</td> <td>4</td> </tr> <tr> <td>$L \leq 10\text{mm}, W < 0.05\text{mm}$</td> <td>*</td> </tr> </tbody> </table>				Dimension	Acceptable number	Class Of Defects	AQL Level	$W > 0.1\text{mm}, L > 10\text{mm}$	0	Minor	1.5	$L \leq 10\text{mm}, 0.05\text{mm} < W \leq 0.1\text{mm}$	4	$L \leq 10\text{mm}, W < 0.05\text{mm}$	*				
		Dimension	Acceptable number	Class Of Defects	AQL Level																
		$W > 0.1\text{mm}, L > 10\text{mm}$	0	Minor	1.5																
		$L \leq 10\text{mm}, 0.05\text{mm} < W \leq 0.1\text{mm}$	4																		
		$L \leq 10\text{mm}, W < 0.05\text{mm}$	*																		
		L : Length W : Width * : Disregard																			
		Dent and spots shape on the polarize & TP (Note:2): (Note: 5)																			
<table border="1"> <thead> <tr> <th>Dimension</th> <th>Acceptable number</th> <th>Class Of Defects</th> <th>AQL Level</th> </tr> </thead> <tbody> <tr> <td>$D \leq 0.3$</td> <td>*</td> <td rowspan="3">Minor</td> <td rowspan="3">1.5</td> </tr> <tr> <td>$0.3 < D \leq 0.8$</td> <td>4</td> </tr> <tr> <td>$D > 0.8$</td> <td>0</td> </tr> </tbody> </table>				Dimension	Acceptable number	Class Of Defects	AQL Level	$D \leq 0.3$	*	Minor	1.5	$0.3 < D \leq 0.8$	4	$D > 0.8$	0						
Dimension	Acceptable number	Class Of Defects	AQL Level																		
$D \leq 0.3$	*	Minor	1.5																		
$0.3 < D \leq 0.8$	4																				
$D > 0.8$	0																				
D = (Long + Short) / 2 * : Disregard																					

	OUTGOING QUALITY STANDARD	PAGE 3 OF 3
TITLE:FUNCTIONAL TEST & INSPECTION CRITERIA		
<p>Note:1.(a)Bright point defect is defined as point defect of R,G,B with area $>1/2$ pixel respectively (b)Dark point defect is defined as visible in full white pattern. (c)The point defect must under 2% ND Filter visible .</p> <p>Note:2 The external inspection should be conducted at the distance 30 ± 5cm between the eyes of inspector and thepanel .</p> <p>Note:3 Luminance measurement for contrast ratio is at the distance 50 ± 5cm between the detective head and the panelwith ambient illuminance less than 1 lux. Contrast ratio is obtained at optimum view angle.</p> <p>Note:4 W-Width in mm , L-length of Max.(L1,L2) in mm.</p>		
		
<p>Note:5 Spot Foreign Material ($W \geq L/4$)</p>		
		

1 Handling Precautions

- 1.1 The display panel is made of glass and polarizer. As glass is fragile. It tends to become or chipped during handling especially on the edges. Please avoid dropping or jarring. Do not subject it to a mechanical shock by dropping it or impact.
- 1.2 If the display panel is damaged and the liquid crystal substance leaks out, be sure not to get any in your mouth. If the substance contacts your skin or clothes, wash it off using soap and water.
- 1.3 Do not apply excessive force to the display surface or the adjoining areas since this may cause the color tone to vary. Do not touch the display with bare hands. This will stain the display area and degraded insulation between terminals (some cosmetics are determined to the polarizer).
- 1.4 The polarizer covering the display surface of the LCD module is soft and easily scratched. Handle this polarizer carefully. Do not touch, push or rub the exposed polarizers with anything harder than an HB pencil lead (glass, tweezers, etc.). Do not put or attach anything on the display area to avoid leaving marks on it. Condensation on the surface and contact with terminals due to cold will damage, stain or dirty the polarizer. After products are tested at low temperature they must be warmed up in a container before coming in to contact with room temperature air.
- 1.5 If the display surface becomes contaminated, breathe on the surface and gently wipe it with a soft dry cloth. If it is heavily contaminated, moisten cloth with one of the following solvents
 - Isopropyl alcohol
 - Ethyl alcoholDo not scrub hard to avoid damaging the display surface.
- 1.6 Solvents other than those above-mentioned may damage the polarizer. Especially, do not use the following.
 - Water
 - Ketone
 - Aromatic solventsWipe off saliva or water drops immediately, contact with water over a long period of time may cause deformation or color fading. Avoid contact with oil and fats.
- 1.7 Exercise care to minimize corrosion of the electrode. Corrosion of the electrodes is accelerated by water droplets, moisture condensation or a current flow in a high-humidity environment.
- 1.8 Install the LCD Module by using the mounting holes. When mounting the LCD module make sure it is free of twisting, warping and distortion. In particular, do not forcibly pull or bend the I/O cable or the backlight cable.
- 1.9 Do not attempt to disassemble or process the LCD module.
- 1.10 NC terminal should be open. Do not connect anything.
- 1.11 If the logic circuit power is off, do not apply the input signals.
- 1.12 Electro-Static Discharge Control, Since this module uses a CMOS LSI, the same careful attention should be paid to electrostatic discharge as for an ordinary CMOS IC. To prevent destruction of the elements by static electricity, be careful to maintain an optimum work environment.
 - Before removing LCM from its packing case or incorporating it into a set, be sure the module and your body have the same electric potential. Be sure to ground the body when handling the LCD modules.
 - Tools required for assembling, such as soldering irons, must be properly grounded. Make certain the AC power source for the soldering iron does not leak. When using an electric screwdriver to attach LCM, the screwdriver should be of ground potentiality to minimize as much as possible any transmission of electromagnetic waves produced sparks coming from the commutator of the motor.
 - To reduce the amount of static electricity generated, do not conduct assembling

and other work under dry conditions. To reduce the generation of static electricity be careful that the air in the work is not too dry. A relative humidity of 50%-60% is recommended. As far as possible make the electric potential of your work clothes and that of the work bench the ground potential.

- The LCD module is coated with a film to protect the display surface. Exercise care when peeling off this protective film since static electricity may be generated.

1.13 Since LCM has been assembled and adjusted with a high degree of precision, avoid applying excessive shocks to the module or making any alterations or modifications to it.

- Do not alter, modify or change the shape of the tab on the metal frame.
- Do not make extra holes on the printed circuit board, modify its shape or change the positions of components to be attached.
- Do not damage or modify the pattern writing on the printed circuit board.
- Absolutely do not modify the zebra rubber strip (conductive rubber) or heat seal connector.
- Except for soldering the interface, do not make any alterations or modifications with a soldering iron.
- Do not drop, bend or twist the LCM.

2 Handling precaution for LCM

2.1 LCM is easy to be damaged. Please note below and be careful for handling.

2.2 Correct handling:



As above picture, please handle with anti-static gloves around LCM edges.

2.3 Incorrect handling:



Please don't touch IC directly.

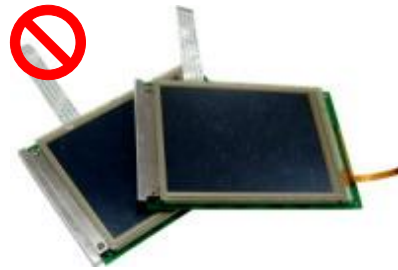

Please don't stack LCM.



Please don't hold the surface of panel.

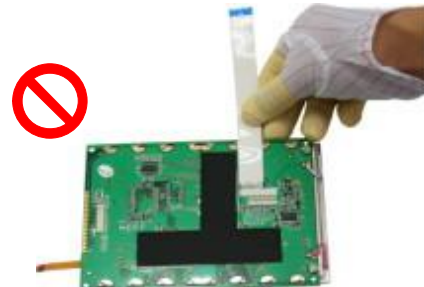

Please don't stretch interface of output, such as FPC cable.

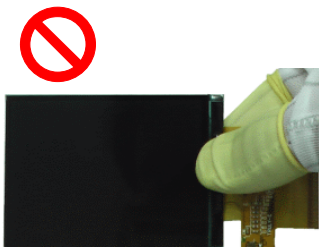

Please don't hold the surface of IC.

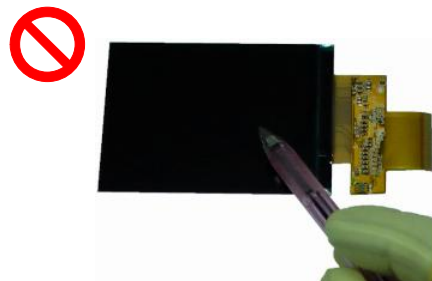

Please don't operate with sharp stick such as pens.

3 Storage Precautions

3.1 When storing the LCD modules, the following precaution are necessary.

- 3.1.1 Store them in a sealed polyethylene bag. If properly sealed, there is no need for the desiccant.
- 3.1.2 Store them in a dark place. Do not expose to sunlight or fluorescent light, keep the temperature between 0°C and 35°C, and keep the relative humidity between 40%RH and 60%RH.
- 3.1.3 The polarizer surface should not come in contact with any other objects (We advise you to store them in the anti-static electricity container in which they were shipped).

3.2 Others 其它

- 3.2.1 Liquid crystals solidify under low temperature (below the storage temperature range) leading to defective orientation or the generation of air bubbles (black or white). Air bubbles may also be generated if the module is subject to a low temperature.
- 3.2.2 If the LCD modules have been operating for a long time showing the same display patterns, the display patterns may remain on the screen as ghost images and a slight contrast irregularity may also appear. A normal operating status can be regained by suspending use for some time. It should be noted that this phenomenon does not adversely affect performance reliability.
- 3.2.3 To minimize the performance degradation of the LCD modules resulting from destruction caused by static electricity etc., exercise care to avoid holding the following sections when handling the modules.
 - 3.2.3.1 - Exposed area of the printed circuit board.
 - 3.2.3.2 - Terminal electrode sections.

4 USING LCD MODULES

4.1 Installing LCD Modules

The hole in the printed circuit board is used to fix LCM as shown in the picture below.

Attend to the following items when installing the LCM.

4.1.1 Cover the surface with a transparent protective plate to protect the polarizer and LC cell.

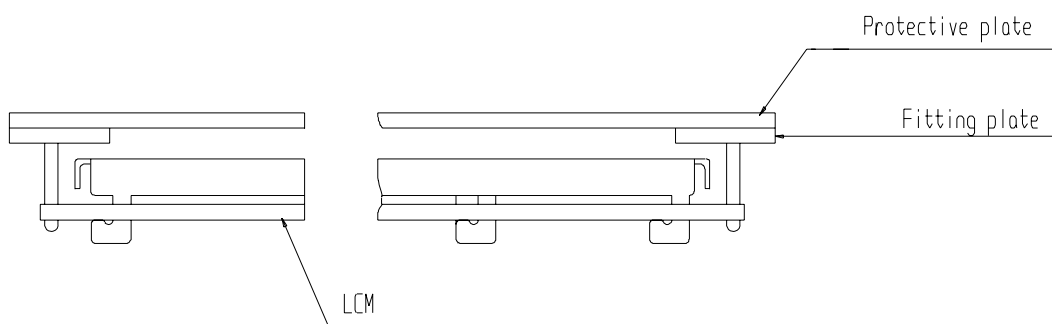

4.1.2 When assembling the LCM into other equipment, the spacer to the bit between the LCM and the fitting plate should have enough height to avoid causing stress to the module surface, refer to the individual specifications for measurements. The measurement tolerance should be ± 0.1 mm.

4.3 Precaution for soldering the LCM

	Manual soldering	Machine drag soldering	Machine press soldering
No RoHS Product	290°C ~350°C. Time : 3-5S.	330°C ~350°C. Speed : 15-17 mm/s.	300°C ~330°C. Time : 3-6S. Press: 0.8~1.2Mpa
RoHS Product	340°C ~370°C. Time : 3-5S.	350°C ~370°C. Speed : 15-17 mm/s.	330°C ~360°C. Time : 3-6S. Press: 0.8~1.2Mpa

- 4.3.1 If soldering flux is used, be sure to remove any remaining flux after finishing to soldering operation (This does not apply in the case of a non-halogen type of flux). It is recommended that you protect the LCD surface with a cover during soldering to prevent any damage due to flux spatters.
- 4.3.2 When soldering the electroluminescent panel and PC board, the panel and board should not be detached more than three times. This maximum number is determined by the temperature and time conditions mentioned above, though there may be some variance depending on the temperature of the soldering iron.
- 4.3.3 When remove the electroluminescent panel from the PC board, be sure the solder has completely melted, the soldered pad on the PC board could be damaged.

4.4 Precautions for Operation

- 4.4.1 Viewing angle varies with the change of liquid crystal driving voltage (VLCD). Adjust VLCD to show the best contrast.
- 4.4.2 It is an indispensable condition to drive LCD's within the specified voltage limit since the higher voltage then the limit cause the shorter LCD life. An electrochemical reaction due to direct current causes LCD's undesirable deterioration, so that the use of direct current drive should be avoided.
- 4.4.3 Response time will be extremely delayed at lower temperature than the operating temperature range and on the other hand at higher temperature LCD's show dark color in them. However those phenomena do not mean malfunction or out of order with LCD's, which will come back in the specified operating temperature.
- 4.4.4 If the display area is pushed hard during operation, the display will become abnormal. However, it will return to normal if it is turned off and then back on.
- 4.4.5 A slight dew depositing on terminals is a cause for electro-chemical reaction resulting in terminal open circuit. Usage under the maximum operating temperature, 50%RH or less is required.
- 4.4.6 Input logic voltage before apply analog high voltage such as LCD driving voltage when power on. Remove analog high voltage before logic voltage when power off the module. Input each signal after the positive/negative voltage becomes stable.
- 4.4.7 Please keep the temperature within the specified range for use and storage. Polarization degradation, bubble generation or polarizer peel-off may occur with high temperature and high humidity.

4.5 Safety

- 4.5.1 It is recommended to crush damaged or unnecessary LCDs into pieces and wash them off with solvents such as acetone and ethanol, which should later be burned.
- 4.5.2 If any liquid leaks out of a damaged glass cell and comes in contact with the hands, wash off thoroughly with soap and water.

4.6 Limited Warranty

Unless agreed between Multi-Inno and the customer, Multi-Inno will replace or repair any of its LCD modules which are found to be functionally defective when inspected in accordance with Multi-Inno LCD acceptance standards (copies available upon request) for a period of one year from date of production. Cosmetic/visual defects must be returned to Multi-Inno within 90 days of shipment. Confirmation of such date shall be based on data code on product. The warranty liability of Multi-Inno limited to repair and/or replace on the terms set forth above. Multi-Inno will not be responsible for any subsequent or consequential events.

4.7 Return LCM under warranty

4.7.1 No warranty can be granted if the precautions stated above have been disregarded. The typical examples of violations are :

4.7.1.1 - Broken LCD glass.

4.7.1.2 - PCB eyelet is damaged or modified.

4.7.1.3 -PCB conductors damaged.

4.7.1.4 - Circuit modified in any way, including addition of components.

4.7.1.5 - PCB tampered with by grinding, engraving or painting varnish.

4.7.1.6 - Soldering to or modifying the bezel in any manner.

4.7.2 Module repairs will be invoiced to the customer upon mutual agreement. Modules must be returned with sufficient description of the failures or defects. Any connectors or cable installed by the customer must be removed completely without damaging the PCB eyelet, conductors and terminals.

■ PACKING SPECIFICATION

Please consult our technical department for detail information.

■ PRIOR CONSULT MATTER

- 1 For Multi-Inno standard products, we keep the right to change material, process ... for improving the product property without prior notice to our customer.
- 2 For OEM products, if any changes are needed which may affect the product property, we will consult with our customer in advance.
- 3 If you have special requirement about reliability condition, please let us know before you start the test on our samples.