



**MULTI-INNO TECHNOLOGY CO., LTD.**

[www.multi-inno.com](http://www.multi-inno.com)

## LCD MODULE SPECIFICATION

**Model : MI0350ADT-2**

This module uses ROHS material

### For Customer's Acceptance:

Customer	
Approved	
Comment	

This specification may change without prior notice in order to improve performance or quality. Please contact Multi-Inno for updated specification and product status before design for this product or release of this order.

Revision	1.0
Engineering	
Date	2013-12-02
Our Reference	



**REVISION RECORD**

REV NO.	REV DATE	CONTENTS	REMARKS
1.0	2013-12-02	First Release	

# CONTENTS

- GENERAL INFORMATION
- EXTERNAL DIMENSIONS
- ABSOLUTE MAXIMUM RATINGS
- ELECTRICAL CHARACTERISTICS
- BACKLIGHT CHARACTERISTICS
- ELECTRO-OPTICAL CHARACTERISTICS
- INTERFACE DESCRIPTION
- BLOCK DIAGRAM
- APPLICATION NOTES
- CTP GENERAL SPECIFICATIONS
- RELIABILITY TEST
- INSPECTION CRITERION
- PRECAUTIONS FOR USING LCD MODULES
- PRIOR CONSULT MATTER

**■ GENERAL INFORMATION**

Item	Contents	Unit
LCD type	TFT/Transmissive	/
Size	3.5	Inch
Viewing direction	12:00 (without image inversion and least brightness change)	O'Clock
Gray scale inversion direction	6:00 (contrast peak located at)	O'Clock
Module area (W × H×T)	79.9×68.9×4.825	mm <sup>3</sup>
Active area (W×H)	70.08×52.56	mm <sup>2</sup>
Number of Dots	320(RGB)×240	/
Driver IC	SSD2119	/
CTP IC	HX8526	/
Interface Type	1. 8/9/16/18-bit 6800-series/8080-series Parallel Interface 2. Serial Peripheral Inerface(SPI) 3. 18-/16-bit RGB interface(OE,DOTCLK, HSYNC, VSYNC,DB[17:0]) 4. VSYNC interface(system interface+VSYNC) 5. WSYNC interface(system interface+WSYNC)	/
Pixel arrangement	RGB vertical stripe	/
Input voltage	3.3	V
Backlight type	6 LEDs	/
Colors	262K	/
With/Without TSP	With CTP	/
Weight	TBD	g

Note 1: RoHS compliant;

Note 2: LCM weight tolerance: ± 5% .

**EXTERNAL DIMENSIONS**

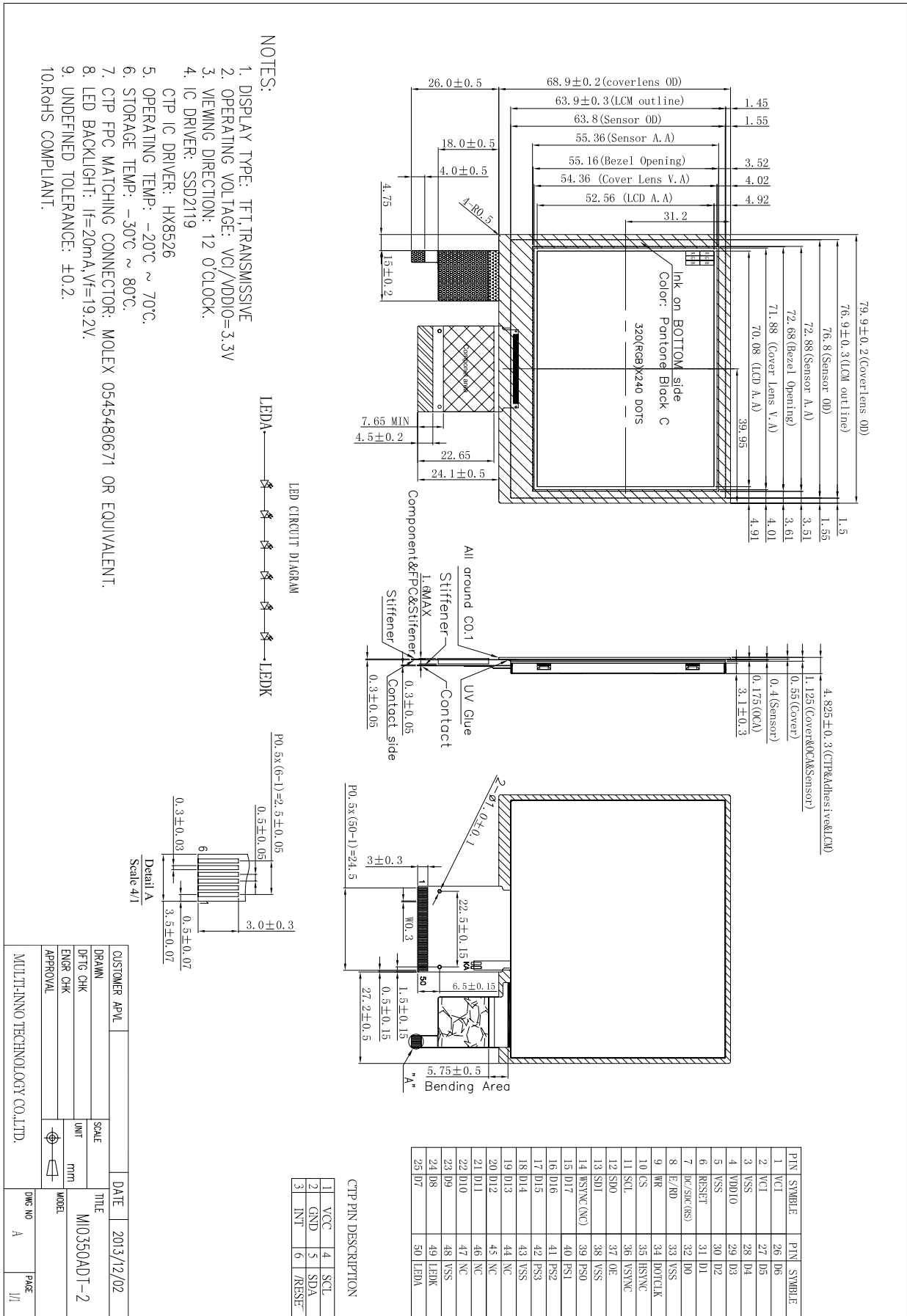

### CTP OUTLINE DRAWING

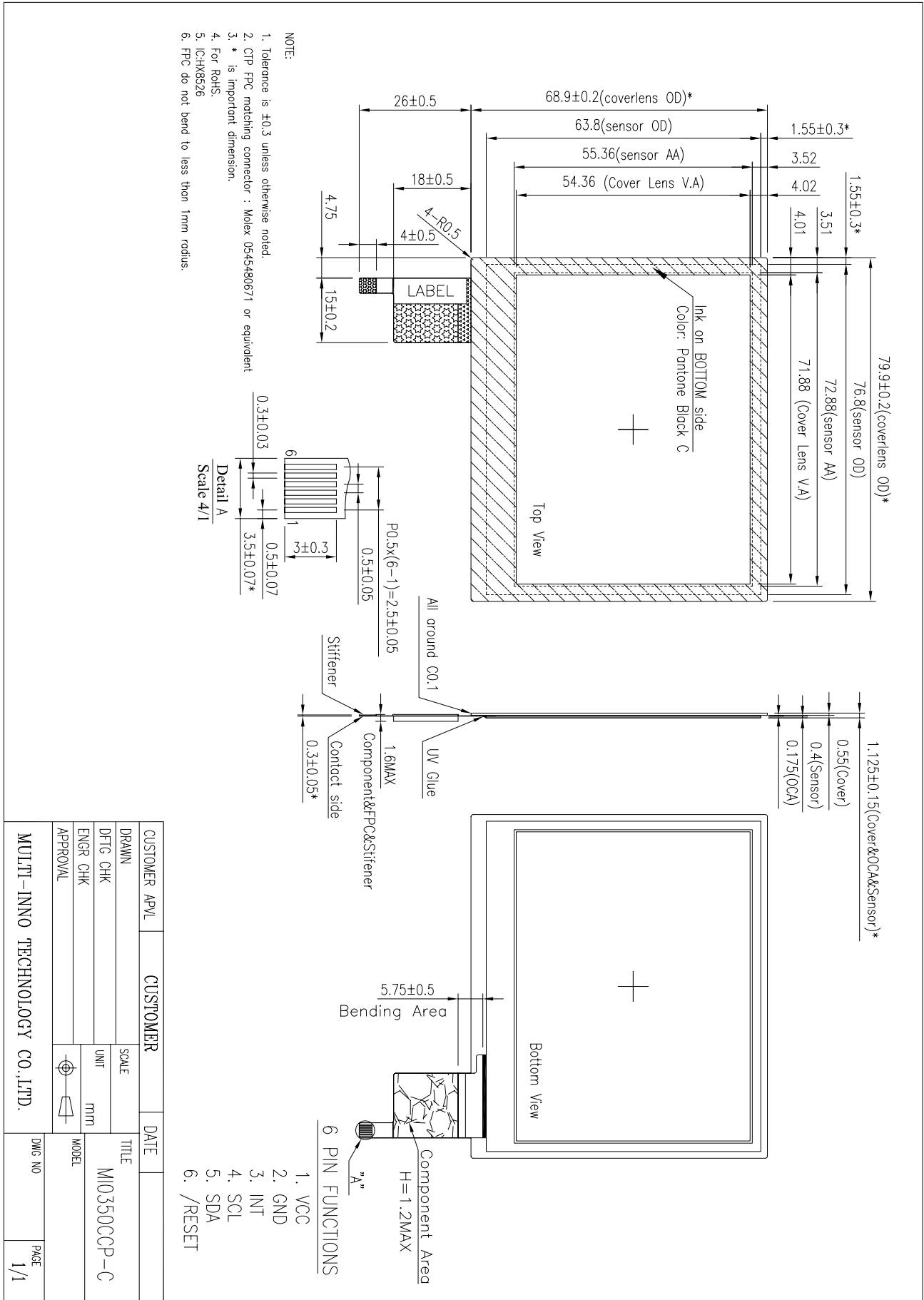

**■ABSOLUTE MAXIMUM RATINGS**

Parameter	Symbol	Min	Max	Unit
Supply voltage	V <sub>CI</sub>	-0.3	4.0	V
Input voltage for logic	V <sub>DDIO</sub>	-0.5	V <sub>CC</sub> +0.3	V
Supply current(One LED)	I <sub>LED</sub>	-	30	mA
Operatingtemperature	T <sub>op</sub>	-20	70	°C
Storagetemperature	T <sub>ST</sub>	-30	80	°C
Humidity	RH	-	90%(Max60°C)	RH

**■ELECTRICAL CHARACTERISTICS**

## DC CHARACTERISTICS

Parameter	Symbol	Min	Typ	Max	Unit
Supply voltage for logic	V <sub>CI</sub>	2.5	3.3	3.6	V
Inputvoltage'H'level	V <sub>IH</sub>	0.8V <sub>CI</sub>	-	V <sub>CI</sub>	V
Inputvoltage'L'level	V <sub>IL</sub>	-0.3	-	0.2V <sub>CI</sub>	V
Input leakage current	I <sub>LKG</sub>	-	-	-	μ A
LED forward voltage	V <sub>f</sub>	3.0	3.2	3.4	V
Input backlight current(one LED)	I <sub>LED</sub>	-	20	25	mA
LED life time	-	30,000	50,000	-	Hr

## ■ELECTRO-OPTICAL CHARACTERISTICS

Item	Symbol	Condition	Min	Typ	Max	Unit	Remark	Note
Response time	Tr +Tf	$\theta=0^\circ$ $\varnothing=0^\circ$ Ta=25°C	-	25	35	ms	Fig.1	4
Contrastratio	Cr		320	400	-	—	FIG 2.	1
Luminance uniformity	$\delta$ WHITE		80	85	-	%	FIG 2.	3
Surface Luminance	Lv		-	330	-	cd/m <sup>2</sup>	FIG 2.	2
Viewing angle range	$\theta$	$\varnothing = 90^\circ$	25	40	-	deg	FIG 3.	6
		$\varnothing = 270^\circ$	45	60	-	deg	FIG 3.	
		$\varnothing = 0^\circ$	45	60	-	deg	FIG 3.	
		$\varnothing = 180^\circ$	45	60	-	deg	FIG 3.	
CIE (x, y) chromaticity	Red x	$\theta=0^\circ$ $\varnothing=0^\circ$ Ta=25°C	-	0.633	-	FIG 2.	5	
	Red y		-	0.329	-			
	Green x		-	0.297	-			
	Green y		-	0.577	-			
	Blue x		-	0.133	-			
	Blue y		-	0.129	-			
	White x		-	0.294	-			
	White y		-	0.334	-			
NTSC Ratio	S	-	-	-	%			

Note 1. Contrast Ratio(CR) is defined mathematically as For more information see FIG 2.

$$\text{Contrast Ratio} = \frac{\text{Average Surface Luminance with all white pixels (P1, P2, P3, P4, P5)}}{\text{Average Surface Luminance with all black pixels (P1, P2, P 3,P4, P5)}}$$

Note 2. Surface luminance is the LCD surface from the surface with all pixels displaying white. For more information see FIG 2.

$$L_v = \text{Average Surface Luminance with all white pixels (P1, P2, P 3, P4, P5)}$$

Note 3. The uniformity in surface luminance ,  $\delta$  WHITE is determined by measuring luminance at each test position 1 through 5, and then dividing the maximum luminance of 5 points luminance by minimum luminance of 5 points luminance. For more information see FIG 2.

$$\delta \text{ WHITE} = \frac{\text{Minimum Surface Luminance with all white pixels (P1, P2, P 3, P4, P5)}}{\text{Maximum Surface Luminance with all white pixels (P1, P2, P 3, P4, P5)}}$$

Note 4. Response time is the time required for the display to transition from White to black(Rise Time, Tr) and from black to white(Decay Time, Tf). For additional information see FIG 1. The test equipment is Autronic-Melchers's ConoScope. Series.

Note 5. CIE (x, y) chromaticity, The x, y value is determined by measuring luminance at each test position 1 through 5,and then make average value.

Note 6. Viewing angle is the angle at which the contrast ratio is greater than 2. For TFT module the contrast ratio is greater than 10. The angles are determined for the horizontal or x axis and the vertical or y axis with respect to the z axis which is normal to the LCD surface. For more information see FIG 3.

Note 7. For viewing angle and response time testing, the testing data is base on Autronic-Melchers's ConoScope. Series Instruments For contrast ratio, Surface Luminance, Luminance uniformity, CIE The test data is base on TOPCON's BM-5 photo detector.



**FIG. 1 The definition of Response Time**

The response time is defined as the following figure and shall be measured by switching the input signal for “black” and “white”.

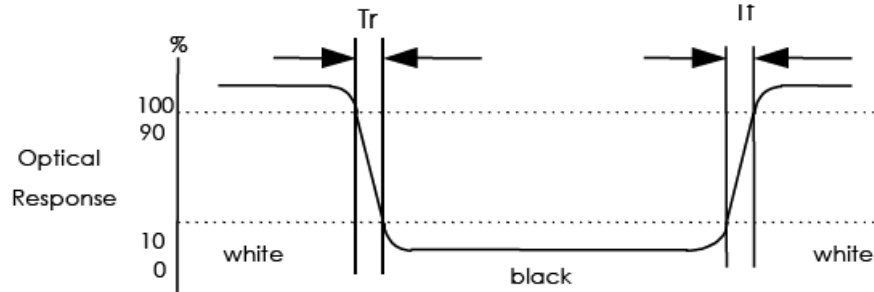
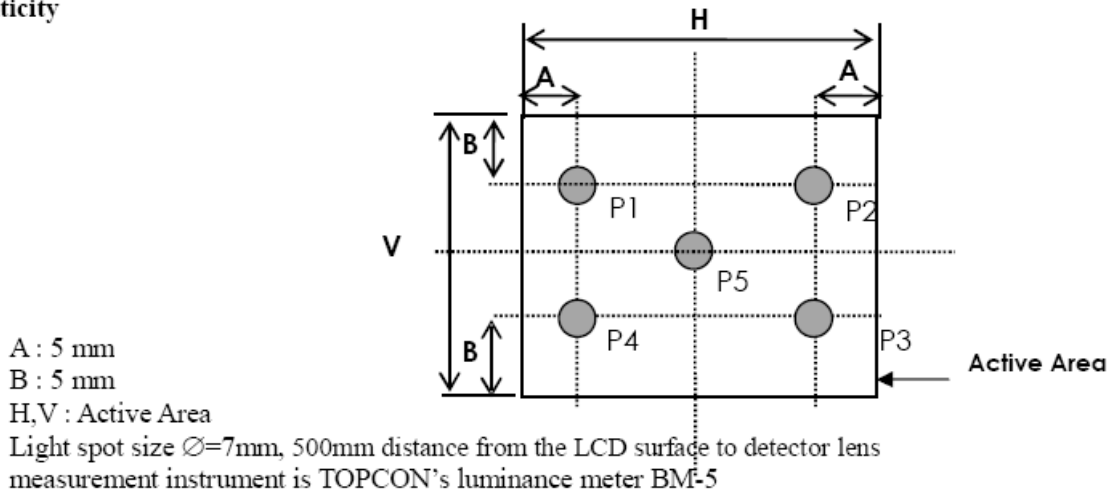
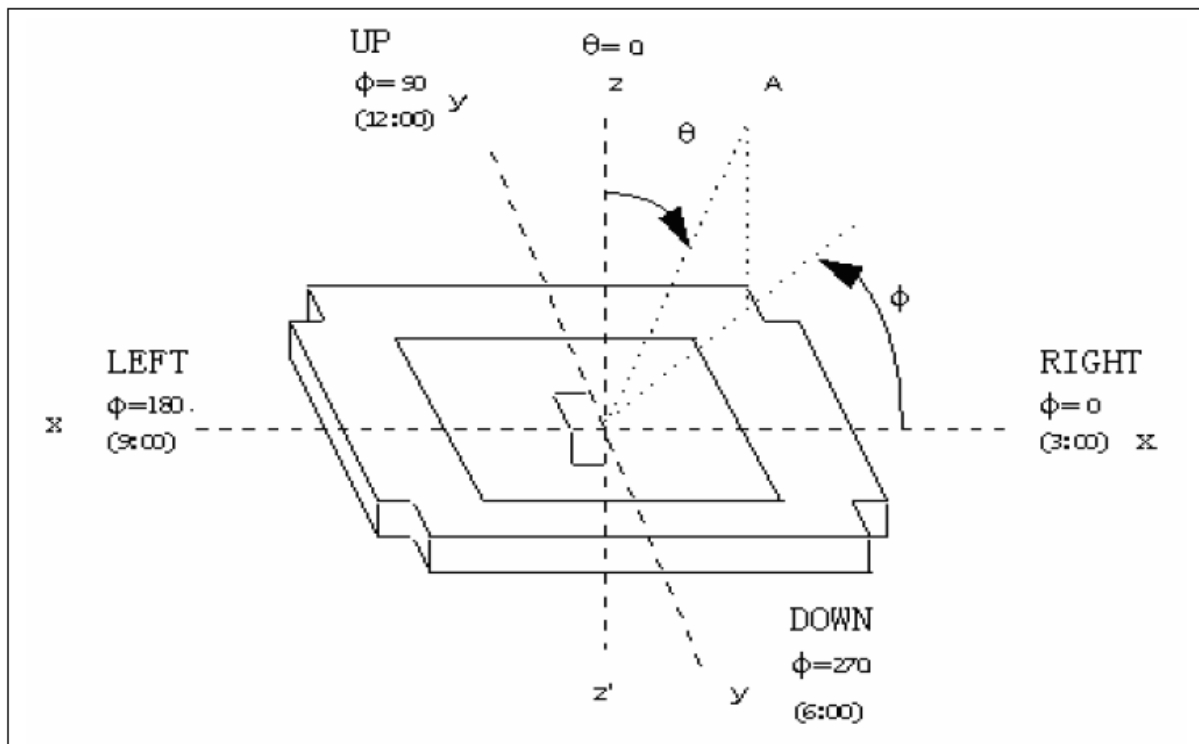
**FIG. 2 Measuring method for Contrast ratio, surface luminance, Luminance uniformity , CIE (x, y) chromaticity**

**FIG. 3 The definition of viewing angle**

## ■ INTERFACE DESCRIPTION

### 1. TFT LCD Panel

Pin No.	Symbol	Description
1~2	VCI	Booster input voltage pin
3	VSS	Ground.
4	VDDIO	Voltage input pin for logic I/O
6	RESB	System reset pin. - An active low pulse at this pin will reset the IC, Connect to VDDIO in normal operation
7	DC/SDC	A register select signal. Low: select an index or status register, High: select a control register. <b>DC</b> : Parallel Interface <b>SDC</b> : Serial Interface
8	E/ $\overline{RD}$	6800-system : <b>E</b> (enable signal) 8080-system : <b>RD</b> (read strobe signal) Serial mode : Not used and should be connected to VDDIO or Vss
9	$\overline{WR}$ (WR)	6800-system : <b>RW</b> (indicates read cycle when High, write cycle when Low) 8080-system : <b>WR</b> (write strobe signal)
10	$\overline{CS}$ (SCS)	<b>CS</b> : Chip select pin for 6800/8080 Parallel Interface <b>SCS</b> : Chip Select pin for Serial Mode Interface
11	SCL	Serial clock input
12	SDO	Data output pin in serial interface
13	SDI	Data input pin in serial interface
14	WSYNC	Ram Write Synchronization output -Leave it OPEN when not used
15~32	DB17~DB0	Data bus.
33	VSS	Ground.
34	DOTCLK	Dot-clock signal and oscillator source.
35	HSYNC	Line Synchronization input
36	VSYNC	Frame/Ram Write Synchronization input
37	OE	Display enable pin from controller.

38	VSS	Ground.
39	PS0	Refer of Table1
40	PS1	
41	PS2	
42	PS3	
43	VSS	Ground.
44~47	NC	Not Connection
48	VSS	Ground.
49	LEDK	Cathode of LED backlight.
50	LEDA	Anode of LED backlight.

**Table1**

PS3	PS2	PS1	PS0	Interface Mode
0	0	0	0	16-bit 6800 parallel interface
0	0	0	1	8-bit 6800 parallel interface
0	0	1	0	16-bit 8080 parallel interface
0	0	1	1	8-bit 8080 parallel interface
0	1	0	0	9-bit generic D[17:9] (262k colour) + 3-wire SPI If 65K color, D12 shorts to D17 internally
0	1	0	1	16-bit generic (262k colour)+ 3-wire SPI
0	1	1	0	18-bit generic (262k colour)+ 3-wire SPI
0	1	1	1	6-bit generic D[17:12] (262k colour) + 3-wire SPI
1	0	0	0	18-bits 6800 parallel interface
1	0	0	1	9-bits 6800 parallel interface
1	0	1	0	18-bit 8080 parallel interface
1	0	1	1	9-bit 8080 parallel interface
1	1	1	0	3-wire SPI
1	1	1	1	4-wire SPI

## 2. CTP PIN CONNECTIONS

No.	Name	I/O	Description
1	VCC	-	Power supply voltage.
2	GND	-	Ground
3	INT	O	Touch Screen Interrupt. Touch Screen Interrupt line; Interrupt active when the line is low.
4	SCL	I	Serial clock line for I <sup>2</sup> C interface.
5	SDA	I/O	Data line for I <sup>2</sup> C interface.
6	/RESET	I	Reset, Active low

### ■ BLOCK DIAGRAM

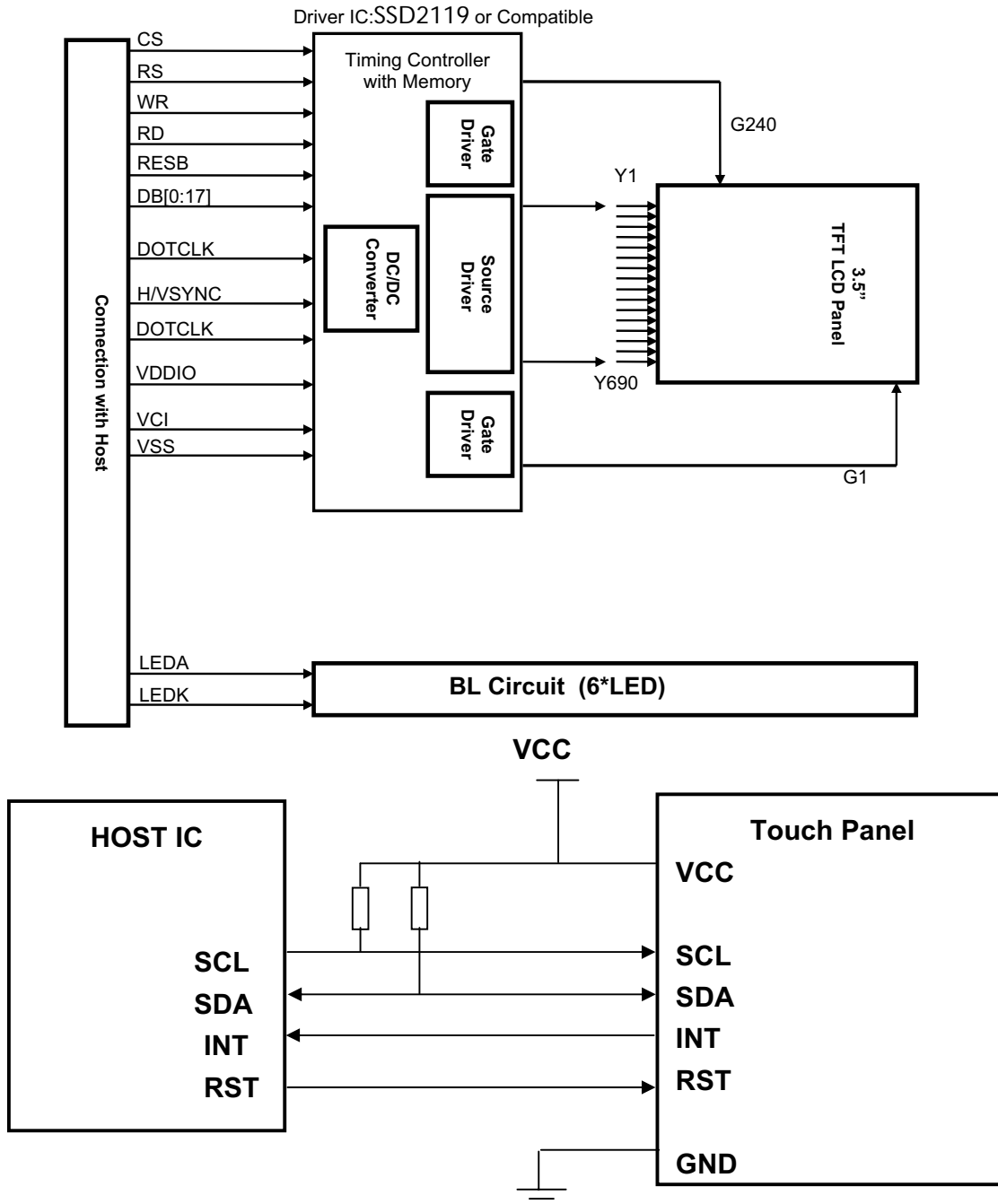

Note : 1. USE APPROPRIATE RESISTOR VALUE DURING HIGH SPEED SCL CLOCK.  
SUGGESTION : RESISTOR RECOMMENDATION : 1K ohm.

2. To reduce the noise from the power, we suggest you use the independent power for the touch panel (VDD)

## ■ APPLICATION CIRCUIT

Please consult our technical department for detail information.

## ■ CTP GENERAL SPECIFICATIONS

### 1. APPLICATION

DVD player, UMPC, POS, MID

### 2. GENERAL SPECIFICATIONS

Composition: 3.5inch Capacitive Touch Panel (CTP).

Interface: I<sup>2</sup>C for the CTP.

Item	Specification	Unit
Type	Transparent type projected capacitive touch panel	
Input mode	Human's finger	
Multi touch	2	Point
Outline Dimension	79.9(W) x 68.9(H) x 1.125(D)	mm
Sensor Active Area	72.88(W)(typ.) x 55.36(H)(typ.)	mm
Transparency	≥ 85	%
Haze	≤ 1.0	%
Weight	TBD	g
Report rate	TBD	Points/sec
Response time	TBD	ms
Point hitting life time	1,000,000 times min.	Note 1
Our components and processes are compliant to RoHS standard		

Note 1: Use 8 mm diameter silicon rubber/force 3N to knock on the same point twice per second (no-operating), after test function check pass.

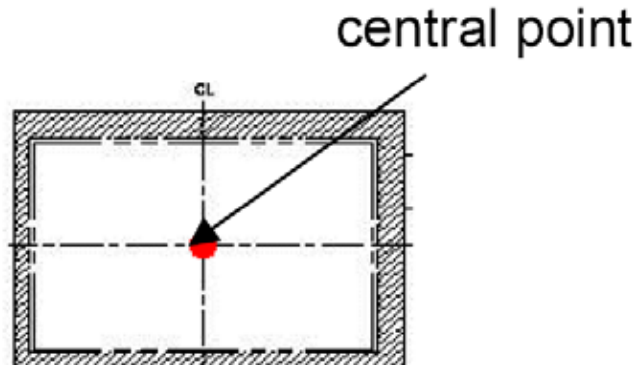

### 3. ABSOLUTE MAXIMUM RATINGS

Parameter	Symbol	Min	Typ	Max	Unit	Notes
Supply voltage	VCC	-0.3	-	7	V	
Switch control signals output current	Output current	-	50	-	mA	
Enable control voltage range	Logic Input	-0.3	-	VCC+0.3	V	
Output Control Driver	Output voltage	-0.3	-	VCC	V	

#### 4. ELECTRICAL CHARACTERISTICS

Parameter	Symbol	Min	Typ	Max	Unit
Supply voltage	VCC	2.7	3.3	3.5	
Input high voltage	V <sub>IH</sub>	0.7 * VCC	-	VCC	V
Input low voltage	V <sub>IL</sub>	0	-	0.3 * VCC	V

#### 5. TIMING SPECIFICATIONS

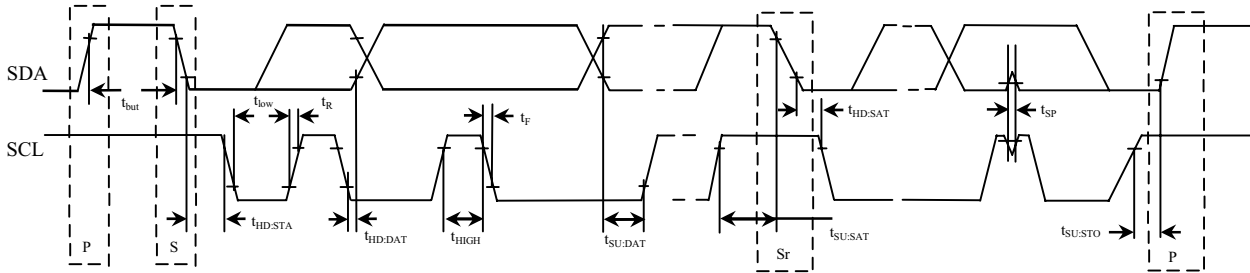

Parameter	Symbol	Standard-Mode I <sup>2</sup> C-BUS		Fast-Mode I <sup>2</sup> C-BUS		Unit
		Min.	Max.	Min.	Max.	
SCL clock frequency	$f_{SCL}$	0	100	0	400	KHz
Bus free time between STOP and START condition	$t_{BUF}$	4.7	-	1.3	-	μs
Hold time (repeated) START condition. After this period, the first clock pulse is generated	$t_{HD:STA}$	4.0	-	0.6	-	μs
LOW period of the SCL clock	$t_{LOW}$	4.7	-	1.3	-	μs
HIGH period of the SCL clock	$t_{HIGH}$	4.0	-	0.6	-	μs
Set-up time for a repeated START condition	$t_{SU:STA}$	4.7	-	0.6	-	μs
Data hold time	$t_{HD:DAT}$	0	-	0	0.9	μs
Data set-up time	$t_{SU:DAT}$	250	-	100	-	μs
Rise time of both SDA and SCL signals	$t_R$	-	1000	20+0.1C <sub>b</sub>	300	μs
Fall time of both SDA and SCL signals	$t_F$	-	300	20+0.1C <sub>b</sub>	300	μs
Set-up time for STOP condition	$t_{SU:STO}$	4.0	-	0.6	-	μs
Capacitive load for each bus line.	C <sub>b</sub>	-	400	-	400	pF

**Note:**

- (1) All values are referred to V<sub>IH</sub> (0.7xVCC) and V<sub>IL</sub> (0.3xVCC) level.
- (2) A device must internally provide a hold time of at least 300ns for the SDA signal (referred to the V<sub>IH</sub> of the SCL signal) in order to bridge the undefined region of the falling edge of SCL.
- (3) The maximum  $t_{HD:DAT}$  has only to be met if the device does not stretch the LOW period ( $t_{LOW}$ ) of the SCL signal.
- (4) A fast-mode I<sup>2</sup>C-bus device can be used in a standard-mode I<sup>2</sup>C-bus system, but the requirement  $t_{SU:DAT} \geq 250$ ns must then be met. This will automatically be the case if the device does not stretch the LOW period of the SCL signal. If such a device does stretch the LOW period of the SCL signal, it must output the next data bit to the SDA line  $t_{R,max} t_{SU:DAT} = 1000+250=1250$ ns (according to the standard-mode I<sup>2</sup>C-bus specification) before the SCL line is released.
- (5) C<sub>b</sub> = total capacitance of one bus line in pF.
- (6) If a spark or noise appear on SDA line and keep more than 25ns, Start or Stop condition will be identified if SCL line keep high at this time.

## 6. INTERFACE AND DATA FORMAT

### 6.1 Transfer protocol (I<sup>2</sup>C interface)

MI0350CCP-C support I<sup>2</sup>C interface that need 2 hardware pin – serial data (SDA) and serial clock (SCL), carry information between the devices connected to the bus. The I<sup>2</sup>C bus supports serial, 8-bit oriented, bi-directional data transferred at a rate up to 100Kbit/s in the standard-mode, or up to 400Kbit/s in the fast-mode.

The data on the SDA line must be stable during the HIGH period of the clock. The HIGH or LOW state of the data line can only change when the clock signal on the SCL line is LOW.

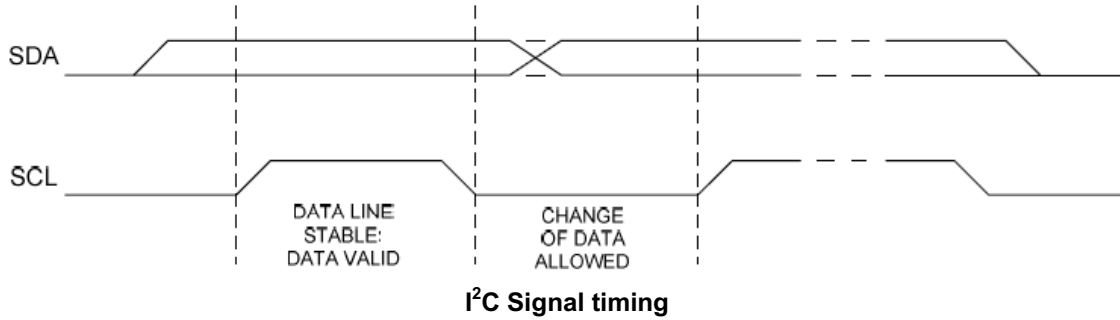

Within the procedure of the I<sup>2</sup>C -bus, unique situations arise which are defined as START and STOP conditions. A HIGH to LOW transition on the SDA line while SCL is HIGH is one such unique case. This situation indicates a START condition. A LOW to HIGH transition on the SDA line while SCL is HIGH defines a STOP condition. START and STOP conditions are always generated by the master. The I<sup>2</sup>C bus is considered to be busy after the START condition. The I<sup>2</sup>C bus is considered to be free again a certain time after the STOP condition.

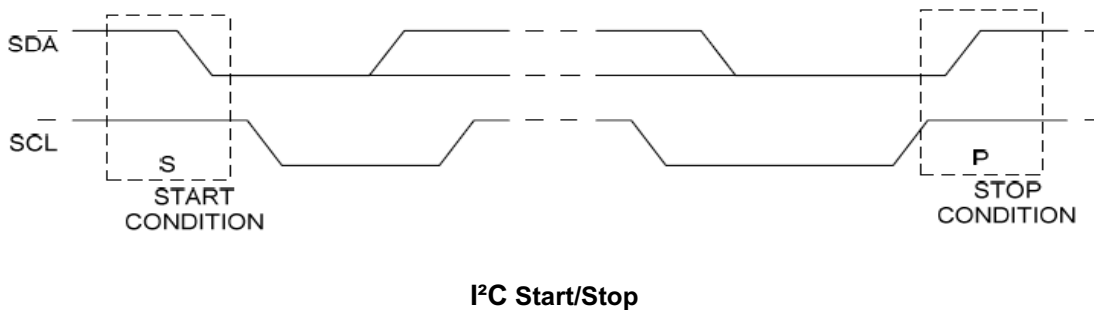

## 6.2 I<sup>2</sup>C data transfer

The CTP MI0350CCP-C I<sup>2</sup>C address is **0x94H(write)** · **0x95H(read)**

Each byte has to be followed by an acknowledge bit. Data is transferred with the most significant bit (MSB) first. Every byte put on the SDA line must be 8-bits long. The number of bytes that can be transmitted per transfer is unrestricted. If controller can't receive or transmit another complete byte of data until it has performed some other function, for example servicing an internal interrupt, it can hold the clock line SCL LOW to force the master into await state. Data transfer then continues when the controller is ready for another byte of data and releases clock line SCL.

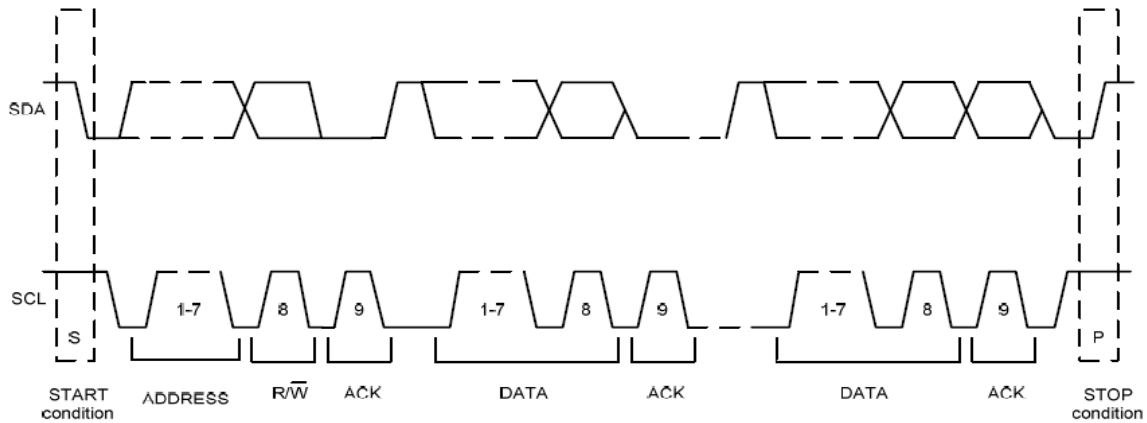

I<sup>2</sup>C data transfer

## 6.3 Format of data frame (I<sup>2</sup>C interface)

### Write mode

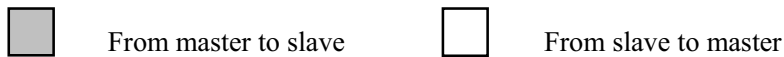
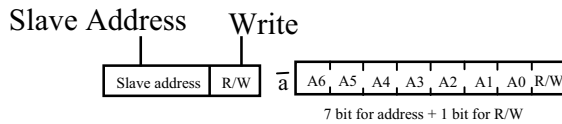
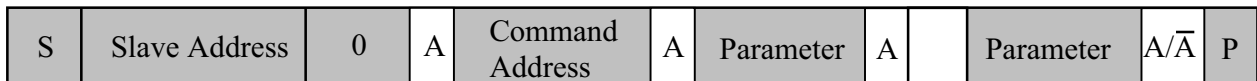

**$\bar{A}$** = acknowledge (SDA LOW)  
**A**= not acknowledge (SDA HIGH)  
**S**= START condition  
**P**= STOP condition

Data Format of writing mode

### Read mode

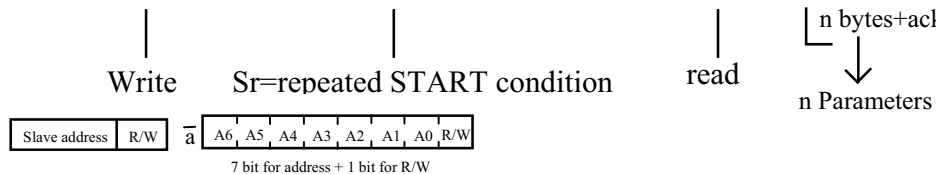
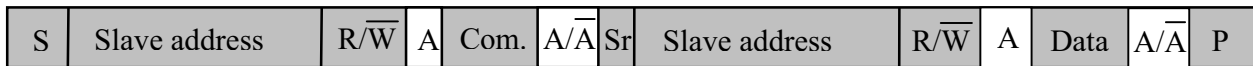

**$\bar{A}$** = acknowledge (SDA LOW)  
**A**= not acknowledge (SDA HIGH)  
**S**= START condition  
**P**= STOP condition

Data Format of reading mode



### 6.4 DATA FORMAT

When finger touch, enter event will occurred and coordinate data will be calculated, and than interrupt signal appear (TSIX pull low).

Baseband should receive data when interrupt occur.

Every point will contains 4 bytes, 2 bytes for X and 2 bytes for Y, it support point is 2, total point data :  $2 \times 4 = 8$  bytes, and 8 bytes will be added for optional information (point count, ID information, hot key, etc.), so totally data length is (support points x 4)+ (8 bytes optional information)

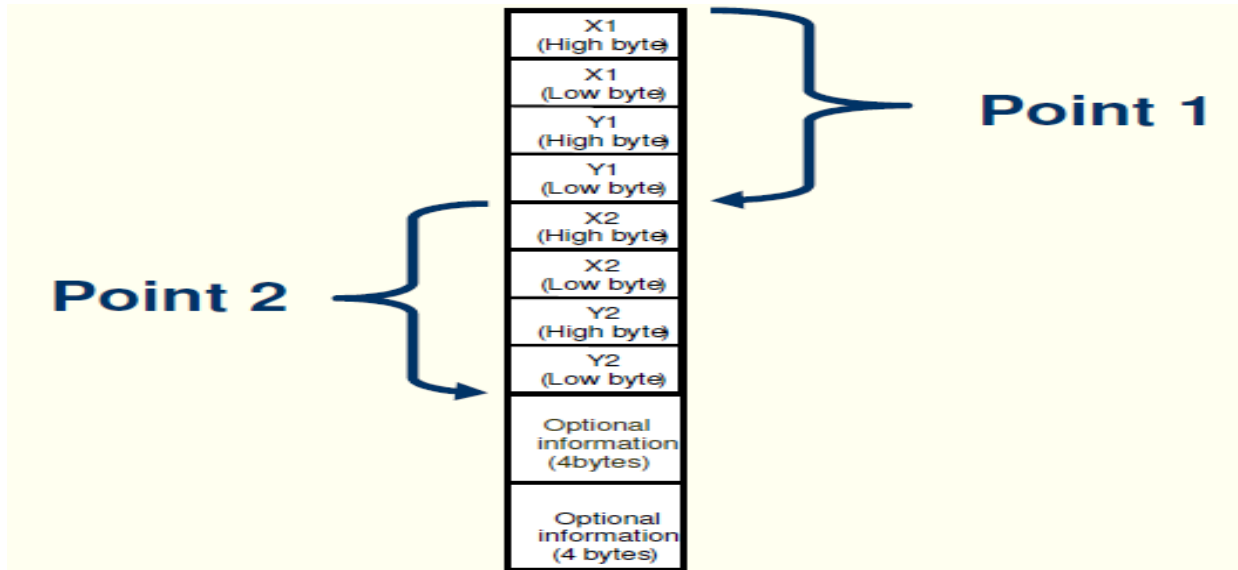

Figure 8.4.1

- When one or more points (but not all) have been touched, other points without touched will be fill **invalid data 0xFFFF** to let baseband distinguish which point has been touched or not.

Example 1: Support 2 points, one point has been touched.

X1 = 150 (0x0096H), Y1 = 230 (0x00E6H)  
 X2 = 65535 (0xFFFFH), Y2 = 65535 (0xFFFFH)

<b>Point 1</b>	Date[0] = 0x00 Date[1] = 0x96 Date[2] = 0x00 Date[3] = 0xE6	Date[8] = 0xFF Date[9] = 0xFF Date[10] = 0xFF Date[11] = 0xFF	No use, invalid data
<b>Point 2</b>	Date[4] = 0xFF Date[5] = 0xFF Date[6] = 0xFF Date[7] = 0xFF	Date[12] = 0xF1 Date[13] = 0x01 Date[14] = 0xFF Date[15] = 0xFF	1 point enter, point count = 0xF1 First point enter, Point ID = 0x01 No use, invalid data

Figure6.4.2

## 7. COMMAND

### 7.1 Command list

ex	operation Code	D7	D6	D5	D4	D3	D2	D1	D0	unction
0	No operation	0	0	0	0	0	0	0	0	-
80	Sleep IN	1	0	0	0	0	0	0	0	-
81	Sleep Out	1	0	0	0	0	0	0	1	-
82	Sense Off	1	0	0	0	0	0	1	0	-
83	Sense On	1	0	0	0	0	0	1	1	-
85	Read Event	1	0	0	0	0	1	0	1	-
	1st parameter	B31	B30	B29	B28	B27	B26	B25	B24	-
	2nd parameter	B23	B22	B21	B20	B19	B18	B17	B16	-
	3rd parameter	B15	B14	B13	B12	B11	B10	B9	B8	-
	4th parameter	B7	B6	B5	B4	B3	B2	B1	B0	-
86	Read All Events	1	0	0	0	0	1	1	0	-
	1st parameter	B31	B30	B29	B28	B27	B26	B25	B24	-
	2nd parameter	B23	B22	B21	B20	B19	B18	B17	B16	-
	3rd parameter	B15	B14	B13	B12	B11	B10	B9	B8	-
	4th parameter	B7	B6	B5	B4	B3	B2	B1	B0	-
	5th parameter	E3	E2	E1	E0	F1	P2	P1	P0	-
	6th parameter	B23	B22	B21	B20	B19	B18	B17	B16	-
	...	:	:	:	:	:	:	:	:	-
(n+1)th parameter	B7	B6	B5	B4	B3	B2	B1	B0	-	
87	Read Latest Event	1	0	0	0	0	1	1	1	-
	1st parameter	B31	B30	B29	B28	B27	B26	B25	B24	-
	2nd parameter	B23	B22	B21	B20	B19	B18	B17	B16	-
	3rd parameter	B15	B14	B13	B12	B11	B10	B9	B8	-
	4th parameter	B7	B6	B5	B4	B3	B2	B1	B0	-
88	Clear Stack	1	0	0	0	1	0	0	0	-
9E	TS Software Reset	1	0	0	1	1	1	1	0	-

### 7.2 User define command list table

ex	operation Code	D7	D6	D5	D4	D3	D2	D1	D0	unction
31h	Device ID	0	0	1	1	0	0	0	1	Response Device ID Code
	1st parameter	85								
	2nd parameter	20								
	3rd parameter	00								
32h	Version ID	0	0	1	1	0	0	1	0	Read Firmware Version



## 8. COMMAND DESCRIPTION

### 8.1 NOP

00 H	NOP (No Operation)									
	DNC	D7	D6	D5	D4	D3	D2	D1	D0	HEX
Command	0	0	0	0	0	0	0	0	0	00
Parameter	No parameter									
Description	This command is an empty command and it does not have any effect on the touch screen.									
Restriction										
Register Availability	Status					Availability				
	TS Sleep Out					Yes				
	TS Sleep In					Yes				
Default	Status					Default Value				
	Power Up Sequence					N/A				
	TS S/W Reset					N/A				
	H/W Reset					N/A				
Flow Chart										

**8.2 TS sleep in (80h)**

80H	TSSLPIN (Touch Screen Sleep In)									
	DNC	D7	D6	D5	D4	D3	D2	D1	D0	HEX
Command	0	1	0	0	0	0	0	0	0	80
parameter	No parameter									
Description	This command causes the touch screen to enter the minimum power consumption mode. MCU interface are register are still working and keeps their contents.									
Restriction	This command has no effect when the touch screen is already in TS Sleep In mode. TS Sleep In Mode can only be left by the TS Sleep Out Command (81h). It will be necessary to wait 5msec before sending next command. This is to allow time for the supply voltages and clock circuits to stabilize. It will be necessary to wait 5msec after sending TS Sleep Out command (when in TS Sleep In Mode) before TS Sleep In command can be sent.									
Register Availability	Status					Availability				
	TS Sleep Out					Yes				
	TS Sleep In					Yes				
Default	Status					Default Value				
	Power Up Sequence					TS Sleep In Mode				
	TS S/W Reset					TS Sleep In Mode				
	H/W Reset					TS Sleep In Mode				
Flow Chart	<pre> graph TD     A[TSSLPIN] --&gt; B[Stop DC/DC converter]     B --&gt; C[Stop Internal Oscillator]     C --&gt; D[TS Sleep In Mode]     </pre>									

**8.3 TS sleep out (81h)**

81H	TSSLPOUT (Touch Screen Sleep Out)									
	DNC	D7	D6	D5	D4	D3	D2	D1	D0	HEX
Command	0	1	0	0	0	0	0	0	1	81
parameter	No parameter									
Description	This command turns off TS Sleep In mode.									
Restriction	This command has no effect when touch screen is already in TS Sleep Out mode. TS Sleep Out Mode can only be left by the TS Sleep In Command (80h). It will be necessary to wait 5msec before sending next command. This is to allow time for the supply voltages and clock circuits to stabilize. The touch screen loads all touch screen supplier's factory default values to the registers during this 5msec and there cannot be any abnormal effect on the touch screen functionality if factory default and register values are same when this load is done and when the touch screen is already TS Sleep Out – mode. It will be necessary to wait 5msec after sending TS Sleep In command (when in TS Sleep Out mode) before TS Sleep Out command can be sent.									
Register Availability	Status					Availability				
	TS Sleep Out					Yes				
	TS Sleep In					Yes				
Default	Status					Default Value				
	Power Up Sequence					TS Sleep In Mode				
	TS S/W Reset					TS Sleep In Mode				
	H/W Reset					TS Sleep In Mode				
Flow Chart	<pre>                     graph TD                         A[TSSLPOUT] --&gt; B(Start Internal Oscillator)                         B --&gt; C(Start up DC/DC converter)                         C --&gt; D(TS Sleep Out Mode)                     </pre>									

**8.4 TS sense off (82h)**

82H	TSSOFF (Touch Screen Sense Off)									
	DNC	D7	D6	D5	D4	D3	D2	D1	D0	HEX
Command	0	1	0	0	0	0	0	1	0	82
parameter	No parameter									
Description	The touch screen is not sensing touches (= No new events), but the touch screen is still scanning.									
Restriction										
Register Availability	Status					Availability				
	TS Sleep Out					Yes				
	TS Sleep In					Yes				
Default	Status					Default Value				
	Power Up Sequence					TS Sense Off				
	TS S/W Reset					TS Sense Off				
	H/W Reset					TS Sense Off				
Flow Chart	<div style="border: 1px dashed black; padding: 10px;"> <p style="text-align: center;">Legend</p> <div style="display: flex; flex-direction: column; align-items: center;"> <div style="border: 1px solid black; width: 100px; height: 40px; margin-bottom: 5px;"></div> <div style="border: 1px solid black; width: 100px; height: 20px; margin-bottom: 5px; transform: rotate(-15deg);"></div> <div style="border: 1px solid black; width: 100px; height: 30px; margin-bottom: 5px; border-radius: 15px;"></div> <div style="border: 1px solid black; width: 100px; height: 30px; margin-bottom: 5px; border-radius: 15px;"></div> <div style="border: 1px solid black; width: 100px; height: 30px; margin-bottom: 5px; border-radius: 15px;"></div> <div style="border: 1px solid black; width: 100px; height: 50px; margin-bottom: 5px; border-radius: 25px;"></div> </div> <div style="margin-top: 20px; text-align: center;"> <pre> graph TD     A[TSSOFF] --&gt; B([TS Sense Off])             </pre> </div> </div>									

**8.5 TS sense on (83h)**

83H	TSSON (Touch Screen Sense On)									
	DNC	D7	D6	D5	D4	D3	D2	D1	D0	HEX
Command	0	1	0	0	0	0	0	1	1	83
parameter	No parameter									
Description	The touch screen is sensing touches (= No new events).									
Restriction										
Register Availability	Status					Availability				
	TS Sleep Out					Yes				
	TS Sleep In					Yes				
Default	Status					Default Value				
	Power Up Sequence					TS Sense Off				
	TS S/W Reset					TS Sense Off				
	H/W Reset					TS Sense Off				
Flow Chart	<div style="border: 1px dashed black; padding: 10px;"> <p style="text-align: center;">Legend</p> <div style="display: flex; flex-direction: column; align-items: center;"> <div style="border: 1px solid black; width: 100px; height: 30px; margin-bottom: 5px;"></div> <div style="border: 1px solid black; width: 100px; height: 30px; margin-bottom: 5px; transform: rotate(-15deg);"></div> <div style="border: 1px solid black; width: 100px; height: 30px; margin-bottom: 5px; border-radius: 15px;"></div> <div style="border: 1px solid black; width: 100px; height: 30px; margin-bottom: 5px; border-radius: 15px;"></div> <div style="border: 1px solid black; width: 100px; height: 30px; margin-bottom: 5px; border-radius: 15px;"></div> <div style="border: 1px solid black; width: 100px; height: 30px; margin-bottom: 5px; border-radius: 15px;"></div> </div> <div style="margin-top: 20px; text-align: center;"> <pre> graph TD     TSSON[Command: TSSON] --&gt; TS_Sense_On[Mode: TS Sense On]             </pre> </div> </div>									

### 8.6 Read One Event (85h)

85H		ROE (Read One Event)									
		DNC	D7	D6	D5	D4	D3	D2	D1	D0	HEX
Command		0	1	0	0	0	0	1	0	1	85
1	parameter	-	B31	B30	B29	B28	B27	B26	B25	B24	xx
2	parameter	-	B23	B22	B21	B20	B19	B18	B17	B16	xx
3	parameter	-	B15	B14	B13	B12	B11	B10	B9	B8	xx
4	parameter	-	B7	B6	B5	B4	B3	B2	B1	B0	xx
Description		<p>This command returns one touch event what is the oldest co-ordinates or raw counter (dc) values information has been stored on the stock. The event stack is empty after this command.</p> <p>A returning value can be “No Event” if the stock is empty.</p> <p>co-ordinates and related touch information:</p> <p>Touch Width: Report the touched block. For example: if RX=15, TX=10, the total Block is 150 (96h). If it has three touched block, the report value is 03h.</p> <p>Point ID: Report the ID of touched points.</p> <p>Points number: Report the touch number.</p> <div style="text-align: center;"> </div> <p>When one or more points (but not all) have been touched, other points without touched will be fill invalid data 0xFFFF to let baseband distinguish which point has been touched or not.</p>									
Register Availability	Status	Availability									
	TS Sleep Out	Yes									
	TS Sleep In	Yes									



Default	Status	Default Value
	Power Up Sequence	0000 0000h
	TS S/W Reset	0000 0000h
	H/W Reset	0000 0000h
Flow Chart	<p>The flowchart illustrates the communication sequence between a Host and a Touch Screen. It begins with a Command (ROE) sent from the Host to the Touch Screen. This is followed by four sequential Parameter transmissions (Send 1<sup>st</sup> parameter, Send 2<sup>nd</sup> parameter, Send 3<sup>rd</sup> parameter, and Send 4<sup>th</sup> parameter) from the Touch Screen. A legend on the right side of the diagram defines the symbols used: a trapezoid for Command, a parallelogram for Parameter, a hexagon for Touch Screen, a hexagon for Action, a rounded rectangle for Mode, and an oval with a tail for Sequential transfer.</p>	

**8.7 Read All Event (86h)**

86H		RAE (Read All Events)									
		DNC	D7	D6	D5	D4	D3	D2	D1	D0	HEX
Command		0	1	0	0	0	0	1	1	0	86
1	parameter	-	B31	B30	B29	B28	B27	B26	B25	B24	xx
2	parameter	-	B23	B22	B21	B20	B19	B18	B17	B16	xx
3	parameter	-	B15	B14	B13	B12	B11	B10	B9	B8	xx
4	parameter	-	B7	B6	B5	B4	B3	B2	B1	B0	xx
5	parameter	-	E3	E2	E1	E0	F1	P2	P1	P0	xx
6	parameter	-	B23	B22	B21	B20	B19	B18	B17	B16	xx
:		-	:	:	:	:	:	:	:	:	:
(n+1) Parameter		-	B7	B6	B5	B4	B3	B2	B1	B0	xx
Description		This command returns one touch event what is the oldest co-ordinates or raw counter (dc) values information has been stored on the stock. A returning value can be "No Event" if the stock is empty. co-ordinates and related touch information: Touch Width: Report the touched block. For example: if RX=15, TX=10, the total Block is 150 (96h). If it has three touched block, the report value is 03h. Point ID: Report the ID of touched points. Points number: Report the touch number.									
Register Availability		Status			Availability						

	TS Sleep Out	Yes
	TS Sleep In	Yes
Default	Status	Default Value
	Power Up Sequence	All Values 0000 0000h
	TS S/W Reset	All Values 0000 0000h
Flow Chart	<p>The flow chart illustrates the communication between a Host and a Touch Screen. The Host sends a 'Read RAE' command (represented by a trapezoid) to the Touch Screen. The Touch Screen responds with 'Events' (represented by a rounded rectangle with a tail). The process is labeled 'i<sup>2</sup>C Mode'. A legend on the right defines the symbols: Command (trapezoid), Parameter (parallelogram), Touch Screen (rounded rectangle), Action (hexagon), Mode (oval), and Sequential transfer (oval with a tail).</p>	

### 8.8 Read Latest Event (87h)

87H		RLE (Read Latest Event)									
		DNC	D7	D6	D5	D4	D3	D2	D1	D0	HEX
Command		0	1	0	0	0	0	1	1	1	87
1	parameter	-	B31	B30	B29	B28	B27	B26	B25	B24	xx
2	parameter	-	B23	B22	B21	B20	B19	B18	B17	B16	xx
3	parameter	-	B15	B14	B13	B12	B11	B10	B9	B8	xx
4	parameter	-	B7	B6	B5	B4	B3	B2	B1	B0	xx
Description		<p>This command returns one touch event what is the oldest co-ordinates or raw counter (dc) values information has been stored on the stock. The event stack is empty after this command.</p> <p>A returning value can be “No Event” if the stock is empty.</p> <p>co-ordinates and related touch information:</p> <p>Touch Width: Report the touched block. For example: if RX=15, TX=10, the total Block is 150 (96h). If it has three touched block, the report value is 03h.</p> <p>Point ID: Report the ID of touched points.</p> <p>Points number: Report the touch number.</p> <div style="text-align: center;"> </div>									
		<p>When one or more points (but not all) have been touched, other points without touched will be fill invalid data 0xFFFF to let baseband distinguish which point has been touched or not.</p>									

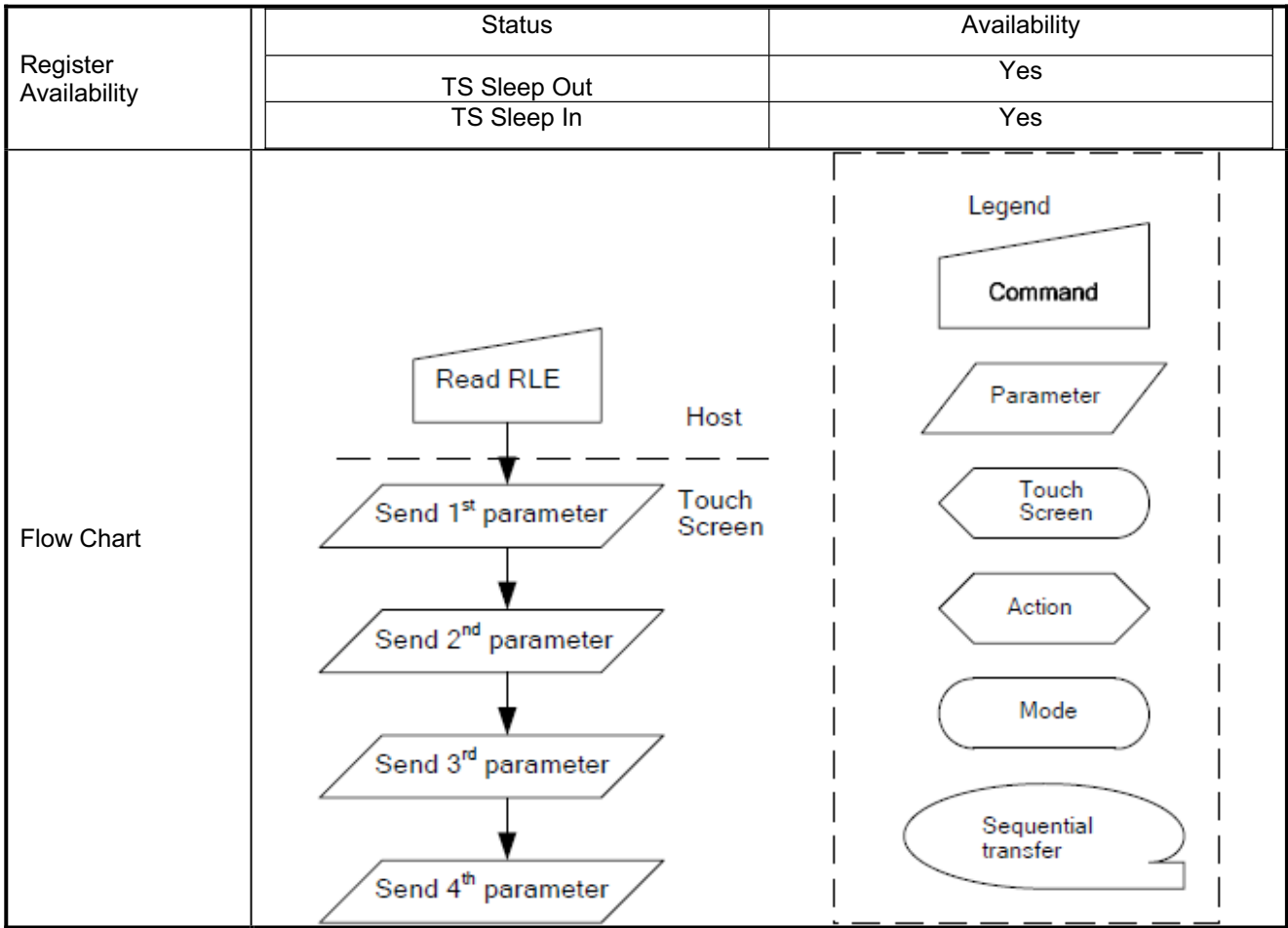

**8.9 Clear Event Stack (88h)**

88H	CLRES (Clear Event Stack)									
	DNC	D7	D6	D5	D4	D3	D2	D1	D0	HEX
Command	0	1	0	0	0	1	0	0	0	88
parameter	No parameter									
Description	This command clears event stack when the only return event can be "No Event".									
Restriction										
Register Availability	Status					Availability				
	TS Sleep Out					Yes				
	TS Sleep In					Yes				
Default	Status					Default Value				
	Power Up Sequence					Empty Stack				
	TS S/W Reset					Empty Stack				
	H/W Reset					Empty Stack				
Flow Chart	<div style="border: 1px dashed black; padding: 10px;"> <p style="text-align: center;">Legend</p> <div style="display: flex; flex-direction: column; align-items: center;"> <div style="border: 1px solid black; width: 100px; height: 30px; margin-bottom: 5px;"></div> <div style="border: 1px solid black; width: 100px; height: 30px; margin-bottom: 5px; transform: rotate(-15deg);"></div> <div style="border: 1px solid black; width: 100px; height: 30px; margin-bottom: 5px; border-radius: 15px;"></div> <div style="border: 1px solid black; width: 100px; height: 30px; margin-bottom: 5px; border-radius: 15px;"></div> <div style="border: 1px solid black; width: 100px; height: 30px; margin-bottom: 5px; border-radius: 15px;"></div> <div style="border: 1px solid black; width: 100px; height: 30px; margin-bottom: 5px; border-radius: 15px;"></div> </div> <div style="margin-top: 20px; text-align: center;"> <pre> graph TD     A[CLRES] --&gt; B([Clear Event Stack])             </pre> </div> </div>									

**8.10 TS Software Reset (9Eh)**

9E H	TSSWRESET (Touch Screen Software Reset)									
	DNC	D7	D6	D5	D4	D3	D2	D1	D0	HEX
Command	0	1	0	0	1	1	1	1	0	9E
parameter	No parameter									
Description	When the Touch Screen Software Reset command is written, it causes a software reset. It resets the commands and parameters to their TS S/W Reset default values. (See default tables in each command description.) Note: The Memory contents are unaffected by this command									
Restriction	It will be necessary to wait 5msec before sending new command following software reset. The touch screen loads all touch screen supplier's factory default values to the registers during this 5msec. If Software Reset is applied during TS Sleep Out mode, it will be necessary to wait 5msec before sending TS Sleep Out command. Touch Screen Software Reset Command cannot be sent during TS Sleep Out sequence.									
Register Availability	Status					Availability				
	TS Sleep Out					Yes				
	TS Sleep In					Yes				
Default	Status					Default Value				
	Power Up Sequence					N/A				
	TS S/W Reset					N/A				
	H/W Reset					N/A				
Flow Chart	<div style="border: 1px dashed black; padding: 10px;"> <p style="text-align: center;">Legend</p> <div style="display: flex; flex-direction: column; align-items: center;"> <div style="border: 1px solid black; padding: 5px; margin-bottom: 5px;">Command</div> <div style="border: 1px solid black; padding: 5px; margin-bottom: 5px;">Parameter</div> <div style="border: 1px solid black; padding: 5px; margin-bottom: 5px;">Touch Screen</div> <div style="border: 1px solid black; padding: 5px; margin-bottom: 5px;">Action</div> <div style="border: 1px solid black; padding: 5px; margin-bottom: 5px;">Mode</div> <div style="border: 1px solid black; padding: 5px; margin-bottom: 5px;">Sequential transfer</div> </div>   <pre>                     graph TD                         A[TSSWRESET] --&gt; B{{Set Commands to TS S/W Default value}}                         B --&gt; C([TS Sleep In Mode])                     </pre> </div>									

### 8.11 Device ID Command (31h)

31 H		Device ID									HEX	
		DNC	D7	D6	D5	D4	D3	D2	D1	D0		
Command		0	0	0	1	1	0	0	0	1	31	
1	parameter	1	85									00..FF
2	parameter	1	26									00..FF
3	parameter	1	00									00..FF
Description		When the Device ID command is written, IC will echo the device ID to master. The index of Device ID command is 31h										
Register Availability		Status					Availability					
		TS Sleep Out					Yes					
		TS Sleep In					Yes					
Default		Status					Default Value					
		Power Up Sequence					N/A					
		TS S/W Reset					N/A					
		H/W Reset					N/A					
Flow Chart												

### 8.12 Version ID Command (32h)

32 H		Device ID									HEX
		DNC	D7	D6	D5	D4	D3	D2	D1	D0	
Command		0	0	0	1	1	0	0	1	0	32
1	parameter	1	SF_Version[3:0]				F_Version[3:0]				00..FF
Description		This command will report the ID code of firmware Version. F_Version [3:0]: The firmware version of flash code. SF_Version [3:0]: The firmware version of self test code.									
Register Availability		Status					Availability				
		TS Sleep Out					Yes				
		TS Sleep In					Yes				
Default		Status					Default Value				
		Power Up Sequence					N/A				
		TS S/W Reset					N/A				
		H/W Reset					N/A				
Flow Chart											



### 8.13 INITIAL CONTROLLER

When want to initial controller, external MCU must execute wake-up command to let IC starting to work (sensing).
Command 0x81H is used to wake-up IC internal power.
Command 0x35H, parameter 0x02H is used to let internal MCU turn-on ready.
Command 0x36H, parameter1 0x0FH, parameter2 0x53H, is used to let flash turn-on ready.
Command 0xDDH, parameter1 0x04H, parameter2 0x02H, is used to turn on MCU fetch flash mode.
Command 0x83H is used to start sensing touch panel.
Command 0x88H is used to clear stack

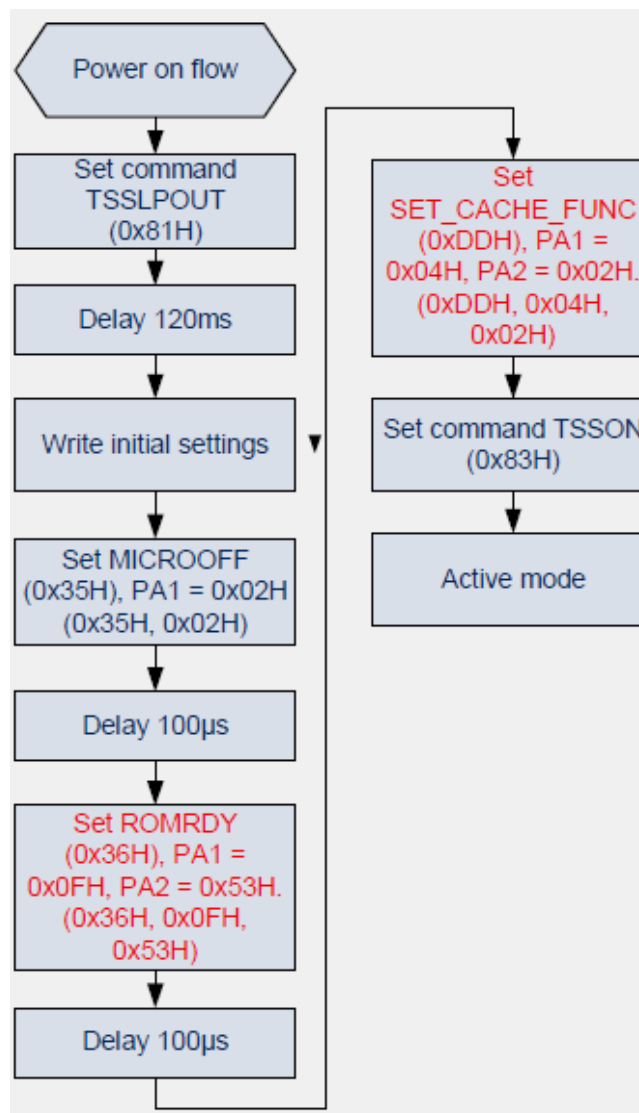

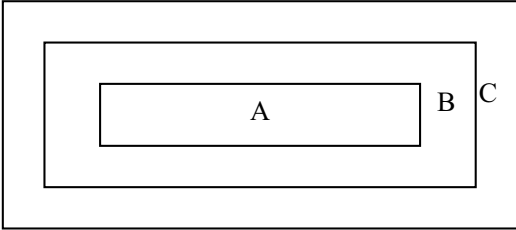

Figure8.13

**■ RELIABILITY TEST**

No.	Test Item	Test Condition	Inspection after test
1	High Temperature Storage	$80 \pm 2^{\circ}\text{C}/240\text{hours}$	1. Functional test is OK. Missing Segment, short, unclear segment, non- display, display abnormally and liquid crystal leak are un-allowed. 2. No low temperature bubbles, end seal loose and fall, frame rainbow.
2	Low Temperature Storage	$-30 \pm 2^{\circ}\text{C}/240\text{hours}$	
3	High Temperature Operating	$70 \pm 2^{\circ}\text{C}/240\text{hours}$	
4	Low Temperature Operating	$-20 \pm 2^{\circ}\text{C}/240\text{hours}$	
5	Temperature Cycle	$-30 \pm 2^{\circ}\text{C} \sim 25 \sim 80 \pm 2^{\circ}\text{C} \times 10\text{cycles}$ (30min.) (5min.) (30min.)	
6	Damp Proof Test	$40^{\circ}\text{C} \pm 5^{\circ}\text{C} \times 90\%\text{RH}/240\text{hours}$	1. Function test is OK. 2. No glass crack, chipped glass, end seal loose and fall, epoxy frame crack 3. No structure loose and fall.
7	Vibration Test	Frequency: 10Hz~55Hz Amplitude: 1.0mm, Each direction on X,Y axe 0.5 hours, circle 2 hours	
8	Dropping test	Drop to the ground from 80cm height, one time, every side of carton.	

## ■ INSPECTION CRITERION

 OUTGOING QUALITY STANDARD	PAGE 1 OF 5
TITLE:FUNCTIONAL TEST & INSPECTION CRITERIA	
<p>This specification is made to be used as the standard acceptance/rejection criteria for Wider Screen TFT-LCD module product.</p> <p><b>1. Sample plan</b></p> <p>Sampling plan according to GB/T2828.1-2003/ISO 2859-1 : 1999 and ANSI/ASQC Z1.4-1993, normal level 2 and based on:</p> <p>Major defect: AQL 0.65 Minor defect: AQL 1.5</p> <p><b>2. Inspection condition</b></p> <p>Viewing distance for cosmetic inspection is about 30cm with bare eyes, and under an environment of 20~40W light intensity, all directions for inspecting the sample should be within 45° against perpendicular line.</p> <p><b>3. Definition of Inspection Item.</b></p> <p>3.1 Definition of inspection zone in LCD.</p> <div style="text-align: center;">  </div> <p>Zone A: character/Digit area                      Zone B: viewing area except Zone A (ZoneA+ZoneB=minimum Viewing area)                      Zone C: Outside viewing area (invisible area after assembly in customer's product)                      ZoneB+ZoneC= Around opaque <u>edge</u> area on TP.</p> <p>Fig.1 Inspection zones in an LCD.</p> <p>Note: As a general rule, visual defects in Zone C are permissible, when it is no trouble for quality and assembly of customer's product.</p>	

**4. Major Defect**

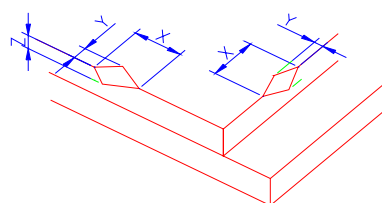
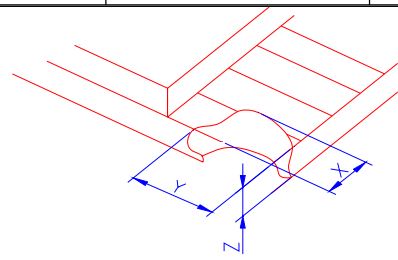

No	Items to be inspected	Criteria	Classification of defects
1	Functional defects	1) No display, Open or miss line 2) Display abnormally, Short 3) Backlight no lighting, abnormal lighting. 4) TP no function	Major
2	Missing	Missing component	
3	Outline dimension	Overall outline dimension beyond the drawing is not allowed	
4	Color tone	Color unevenness, refer to limited sample	Minor
5	Soldering appearance	Good soldering , Peeling off is not allowed.	
6	LCD/Polarizer/TP	Black/White spot/line, scratch, crack, etc.	

**4.1 Criteria (Visual)**

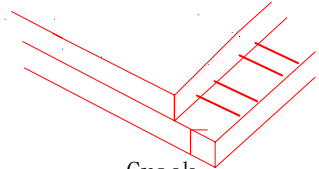
Number	Items	Criteria(mm)						
1.0 LCD Crack/Broken	(1) The edge of LCD broken	 <table border="1" data-bbox="837 1153 1380 1310"> <thead> <tr> <th>X</th> <th>Y</th> <th>Z</th> </tr> </thead> <tbody> <tr> <td>≤3.0mm</td> <td>&lt;Inner border line of the seal</td> <td>≤T</td> </tr> </tbody> </table>	X	Y	Z	≤3.0mm	<Inner border line of the seal	≤T
X	Y	Z						
≤3.0mm	<Inner border line of the seal	≤T						
NOTE: X: Length Y: Width Z: Height L: Length of ITO, T: Height of LCD	(2)LCD corner broken	 <table border="1" data-bbox="901 1601 1324 1680"> <thead> <tr> <th>X</th> <th>Y</th> <th>Z</th> </tr> </thead> <tbody> <tr> <td>≤3.0mm</td> <td>≤L</td> <td>≤T</td> </tr> </tbody> </table>	X	Y	Z	≤3.0mm	≤L	≤T
X	Y	Z						
≤3.0mm	≤L	≤T						

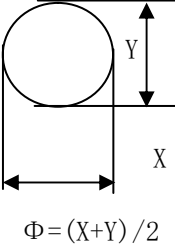
	(3) LCD crack	 <p>Crack Not allowed</p>
--	---------------	---

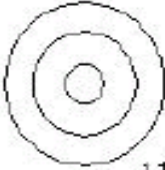
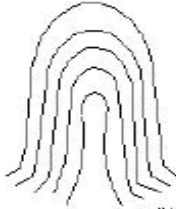
Number	Items	Criteria (mm)																									
2.0	Spot defect  $\Phi = (X+Y) / 2$	① light dot (LCD/TP/Polarizer black/white spot , light dot, pinhole, dent, stain)																									
		<table border="1"> <thead> <tr> <th rowspan="2">Zone Size (mm)</th> <th colspan="3">Acceptable Qty</th> </tr> <tr> <th>A</th> <th>B</th> <th>C</th> </tr> </thead> <tbody> <tr> <td><math>\Phi \leq 0.10</math></td> <td colspan="3">Ignore</td> </tr> <tr> <td><math>0.10 &lt; \Phi \leq 0.15</math></td> <td colspan="3">3 ( distance <math>\geq 10\text{mm}</math>)</td> </tr> <tr> <td><math>0.15 &lt; \Phi \leq 0.2</math></td> <td colspan="3">1</td> </tr> <tr> <td><math>0.2 &lt; \Phi</math></td> <td colspan="3">0</td> </tr> </tbody> </table>	Zone Size (mm)	Acceptable Qty			A	B	C	$\Phi \leq 0.10$	Ignore			$0.10 < \Phi \leq 0.15$	3 ( distance $\geq 10\text{mm}$ )			$0.15 < \Phi \leq 0.2$	1			$0.2 < \Phi$	0				
		Zone Size (mm)		Acceptable Qty																							
			A	B	C																						
		$\Phi \leq 0.10$	Ignore																								
		$0.10 < \Phi \leq 0.15$	3 ( distance $\geq 10\text{mm}$ )																								
		$0.15 < \Phi \leq 0.2$	1																								
		$0.2 < \Phi$	0																								
		② Dim spot (LCD/TP/Polarizer dim dot, light leakage, dark spot)																									
		<table border="1"> <thead> <tr> <th rowspan="2">Zone Size (mm)</th> <th colspan="3">Acceptable Qty</th> </tr> <tr> <th>A</th> <th>B</th> <th>C</th> </tr> </thead> <tbody> <tr> <td><math>\Phi \leq 0.1</math></td> <td colspan="3">Ignore</td> </tr> <tr> <td><math>0.1 &lt; \Phi \leq 0.2</math></td> <td colspan="3">2 ( distance <math>\geq 10\text{mm}</math>)</td> </tr> <tr> <td><math>0.2 &lt; \Phi \leq 0.3</math></td> <td colspan="3">1</td> </tr> <tr> <td><math>\Phi &gt; 0.3</math></td> <td colspan="3">0</td> </tr> </tbody> </table>	Zone Size (mm)	Acceptable Qty			A	B	C	$\Phi \leq 0.1$	Ignore			$0.1 < \Phi \leq 0.2$	2 ( distance $\geq 10\text{mm}$ )			$0.2 < \Phi \leq 0.3$	1			$\Phi > 0.3$	0				
		Zone Size (mm)		Acceptable Qty																							
			A	B	C																						
		$\Phi \leq 0.1$	Ignore																								
		$0.1 < \Phi \leq 0.2$	2 ( distance $\geq 10\text{mm}$ )																								
		$0.2 < \Phi \leq 0.3$	1																								
$\Phi > 0.3$	0																										
③ Polarizer accidented spot																											
<table border="1"> <thead> <tr> <th rowspan="2">Zone Size (mm)</th> <th colspan="3">Acceptable Qty</th> </tr> <tr> <th>A</th> <th>B</th> <th>C</th> </tr> </thead> <tbody> <tr> <td><math>\Phi \leq 0.2</math></td> <td colspan="3">Ignore</td> </tr> <tr> <td><math>0.2 &lt; \Phi \leq 0.5</math></td> <td colspan="3">2 ( distance <math>\geq 10\text{mm}</math>)</td> </tr> <tr> <td><math>\Phi &gt; 0.5</math></td> <td colspan="3">0</td> </tr> </tbody> </table>	Zone Size (mm)	Acceptable Qty			A	B	C	$\Phi \leq 0.2$	Ignore			$0.2 < \Phi \leq 0.5$	2 ( distance $\geq 10\text{mm}$ )			$\Phi > 0.5$	0										
Zone Size (mm)		Acceptable Qty																									
	A	B	C																								
$\Phi \leq 0.2$	Ignore																										
$0.2 < \Phi \leq 0.5$	2 ( distance $\geq 10\text{mm}$ )																										
$\Phi > 0.5$	0																										
Line defect (LCD/TP /Polarizer black/white line, scratch, stain)	<table border="1"> <thead> <tr> <th rowspan="2">Width (mm)</th> <th rowspan="2">Length (mm)</th> <th colspan="3">Acceptable Qty</th> </tr> <tr> <th>A</th> <th>B</th> <th>C</th> </tr> </thead> <tbody> <tr> <td><math>\Phi \leq 0.03</math></td> <td>Ignore</td> <td colspan="2">Ignore</td> <td rowspan="3">Ignore</td> </tr> <tr> <td><math>0.03 &lt; W \leq 0.05</math></td> <td><math>L \leq 3.0</math></td> <td colspan="2"><math>N \leq 2</math></td> </tr> <tr> <td><math>0.05 &lt; W \leq 0.08</math></td> <td><math>L \leq 2.0</math></td> <td colspan="2"><math>N \leq 2</math></td> </tr> <tr> <td><math>0.08 &lt; W</math></td> <td colspan="4">Define as spot defect</td> </tr> </tbody> </table>	Width (mm)	Length (mm)	Acceptable Qty			A	B	C	$\Phi \leq 0.03$	Ignore	Ignore		Ignore	$0.03 < W \leq 0.05$	$L \leq 3.0$	$N \leq 2$		$0.05 < W \leq 0.08$	$L \leq 2.0$	$N \leq 2$		$0.08 < W$	Define as spot defect			
Width (mm)	Length (mm)			Acceptable Qty																							
		A	B	C																							
$\Phi \leq 0.03$	Ignore	Ignore		Ignore																							
$0.03 < W \leq 0.05$	$L \leq 3.0$	$N \leq 2$																									
$0.05 < W \leq 0.08$	$L \leq 2.0$	$N \leq 2$																									
$0.08 < W$	Define as spot defect																										

3.0	Polarizer Bubble	<table border="1" style="width: 100%; border-collapse: collapse;"> <thead> <tr> <th data-bbox="448 315 692 371" rowspan="2">Zone Size (mm)</th> <th colspan="3" data-bbox="692 315 1224 371">Acceptable Qty</th> </tr> <tr> <th data-bbox="692 371 860 427">A</th> <th data-bbox="860 371 1027 427">B</th> <th data-bbox="1027 371 1224 427">C</th> </tr> </thead> <tbody> <tr> <td data-bbox="448 427 692 472"><math>\Phi \leq 0.2</math></td> <td colspan="3" data-bbox="692 427 1224 472">Ignore</td> </tr> <tr> <td data-bbox="448 472 692 517"><math>0.2 &lt; \Phi \leq 0.4</math></td> <td colspan="3" data-bbox="692 472 1224 517">2 (distance <math>\geq 10\text{mm}</math>)</td> </tr> <tr> <td data-bbox="448 517 692 562"><math>0.4 &lt; \Phi \leq 0.6</math></td> <td colspan="3" data-bbox="692 517 1224 562">1</td> </tr> <tr> <td data-bbox="448 562 692 607"><math>0.6 &lt; \Phi</math></td> <td colspan="3" data-bbox="692 562 1224 607">0</td> </tr> </tbody> </table>			Zone Size (mm)	Acceptable Qty			A	B	C	$\Phi \leq 0.2$	Ignore			$0.2 < \Phi \leq 0.4$	2 (distance $\geq 10\text{mm}$ )			$0.4 < \Phi \leq 0.6$	1			$0.6 < \Phi$	0		
Zone Size (mm)	Acceptable Qty																										
	A	B	C																								
$\Phi \leq 0.2$	Ignore																										
$0.2 < \Phi \leq 0.4$	2 (distance $\geq 10\text{mm}$ )																										
$0.4 < \Phi \leq 0.6$	1																										
$0.6 < \Phi$	0																										
4.0	SMT	According to IPC-A-610C class II standard . Function defect and missing part are major defect , the others are minor defect.																									
5.0	TP Related	TP bubble/ accidented spot	<table border="1" style="width: 100%; border-collapse: collapse;"> <thead> <tr> <th data-bbox="639 808 868 864" rowspan="2">Size <math>\Phi</math> (mm)</th> <th colspan="3" data-bbox="868 808 1326 864">Acceptable Qty</th> </tr> <tr> <th data-bbox="868 864 1007 898">A</th> <th data-bbox="1007 864 1155 898">B</th> <th data-bbox="1155 864 1326 898">C</th> </tr> </thead> <tbody> <tr> <td data-bbox="639 864 868 931"><math>\Phi \leq 0.1</math></td> <td colspan="3" data-bbox="868 864 1326 931">Ignore</td> </tr> <tr> <td data-bbox="639 931 868 976"><math>0.1 &lt; \Phi \leq 0.2</math></td> <td colspan="3" data-bbox="868 931 1326 976">2</td> </tr> <tr> <td data-bbox="639 976 868 1021"><math>0.2 &lt; \Phi \leq 0.3</math></td> <td colspan="3" data-bbox="868 976 1326 1021">1</td> </tr> <tr> <td data-bbox="639 1021 868 1066"><math>0.3 &lt; \Phi</math></td> <td colspan="3" data-bbox="868 1021 1326 1066">0</td> </tr> </tbody> </table>		Size $\Phi$ (mm)	Acceptable Qty			A	B	C	$\Phi \leq 0.1$	Ignore			$0.1 < \Phi \leq 0.2$	2			$0.2 < \Phi \leq 0.3$	1			$0.3 < \Phi$	0		
Size $\Phi$ (mm)	Acceptable Qty																										
	A	B	C																								
$\Phi \leq 0.1$	Ignore																										
$0.1 < \Phi \leq 0.2$	2																										
$0.2 < \Phi \leq 0.3$	1																										
$0.3 < \Phi$	0																										
		Assembly deflection	beyond the edge of backlight $\leq 0.15\text{mm}$																								
		Newton Ring	<p>Newton Ring area <math>&gt; 1/3</math> TP area NG</p> <p>Newton Ring area <math>\leq 1/3</math> TP area OK</p>	 <p>1 规律性</p>  <p>2 非规律性</p>  <p>似牛顿环</p>																							

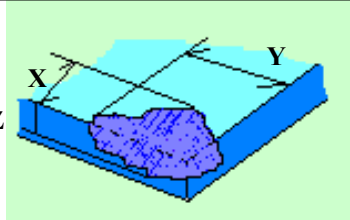
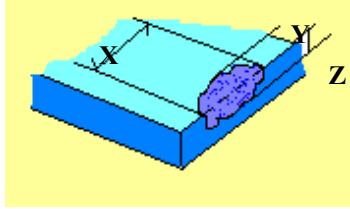
		<p>TP corner broken</p> <p>X: length Y: width Z: height</p>	<table border="1"> <tr> <td>X</td> <td>Y</td> <td>Z</td> </tr> <tr> <td><math>X \leq 3.0\text{mm}</math></td> <td><math>Y \leq 3.0\text{mm}</math></td> <td><math>Z &lt; \text{LCD thickness}</math></td> </tr> </table> <p>* Circuitry broken is not allowed.</p>	X	Y	Z	$X \leq 3.0\text{mm}$	$Y \leq 3.0\text{mm}$	$Z < \text{LCD thickness}$	
X	Y	Z								
$X \leq 3.0\text{mm}$	$Y \leq 3.0\text{mm}$	$Z < \text{LCD thickness}$								
		<p>TP edge broken</p> <p>X: length Y: width Z: height</p>	<table border="1"> <tr> <td>X</td> <td>Y</td> <td>Z</td> </tr> <tr> <td><math>X \leq 6.0\text{mm}</math></td> <td><math>Y \leq 2.0\text{mm}</math></td> <td><math>Z &lt; \text{LCD thickness}</math></td> </tr> </table> <p>* Circuitry broken is not allowed.</p>	X	Y	Z	$X \leq 6.0\text{mm}$	$Y \leq 2.0\text{mm}$	$Z < \text{LCD thickness}$	
X	Y	Z								
$X \leq 6.0\text{mm}$	$Y \leq 2.0\text{mm}$	$Z < \text{LCD thickness}$								

Criteria ( functional items)

Number	Items	Criteria (mm)
1	No display	Not allowed
2	Missing segment	Not allowed
3	Short	Not allowed
4	Backlight no lighting	Not allowed
5	TP no function	Not allowed



## ■ PRECAUTIONS FOR USING LCD MODULES

### 1 Handling Precautions

- 1.1 The display panel is made of glass and polarizer. As glass is fragile. It tends to become or chipped during handling especially on the edges. Please avoid dropping or jarring. Do not subject it to a mechanical shock by dropping it or impact.
- 1.2 If the display panel is damaged and the liquid crystal substance leaks out, be sure not to get any in your mouth. If the substance contacts your skin or clothes, wash it off using soap and water.
- 1.3 Do not apply excessive force to the display surface or the adjoining areas since this may cause the color tone to vary. Do not touch the display with bare hands. This will stain the display area and degraded insulation between terminals (some cosmetics are determined to the polarizer).
- 1.4 The polarizer covering the display surface of the LCD module is soft and easily scratched. Handle this polarizer carefully. Do not touch, push or rub the exposed polarizers with anything harder than an HB pencil lead (glass, tweezers, etc.). Do not put or attach anything on the display area to avoid leaving marks on it. Condensation on the surface and contact with terminals due to cold will damage, stain or dirty the polarizer. After products are tested at low temperature they must be warmed up in a container before coming in to contact with room temperature air.
- 1.5 If the display surface becomes contaminated, breathe on the surface and gently wipe it with a soft dry cloth. If it is heavily contaminated, moisten cloth with one of the following solvents
  - Isopropyl alcohol
  - Ethyl alcoholDo not scrub hard to avoid damaging the display surface.
- 1.6 Solvents other than those above-mentioned may damage the polarizer. Especially, do not use the following.
  - Water
  - Ketone
  - Aromatic solventsWipe off saliva or water drops immediately, contact with water over a long period of time may cause deformation or color fading. Avoid contact with oil and fats.
- 1.7 Exercise care to minimize corrosion of the electrode. Corrosion of the electrodes is accelerated by water droplets moisture condensation or a current flow in a high-humidity environment
- 1.8 Install the LCD Module by using the mounting holes. When mounting the LCD module make sure it is free of twisting, warping and distortion. In particular, do not forcibly pull or bend the I/O cable or the backlight cable.
- 1.9 Do not attempt to disassemble or process the LCD module.
- 1.10 NC terminal should be open. Do not connect anything.
- 1.11 If the logic circuit power is off, do not apply the input signals.
- 1.12 Electro-Static Discharge Control, Since this module uses a CMOS LSI, the same careful attention should be paid to electrostatic discharge as for an ordinary CMOS IC. To prevent destruction of the elements by static electricity, be careful to maintain an optimum work environment.
  - Before removing LCM from its packing case or incorporating it into a set, be sure the module and your body have the same electric potential. Be sure to ground the body when handling the LCD modules.

- Tools required for assembling, such as soldering irons, must be properly grounded. Make certain the AC power source for the soldering iron does not leak. When using an electric screwdriver to attach LCM, the screwdriver should be of ground potential to minimize as much as possible any transmission of electromagnetic waves produced sparks coming from the commutator of the motor.

- To reduce the amount of static electricity generated, do not conduct assembling and other work under dry conditions. To reduce the generation of static electricity be careful that the air in the work is not too dry. A relative humidity of 50%-60% is recommended. As far as possible make the electric potential of your work clothes and that of the work bench the ground potential.

The LCD module is coated with a film to protect the display surface. Exercise care when peeling off this protective film since static electricity may be generated.

1.13 Since LCM has been assembled and adjusted with a high degree of precision, avoid applying excessive shocks to the module or making any alterations or modifications to it.

- Do not alter modify or change the shape of the tab on the metal frame.
- Do not make extra holes on the printed circuit board, modify its shape or change the positions of components to be attached.
- Do not damage or modify the pattern writing on the printed circuit board.
- Absolutely do not modify the zebra rubber strip (conductive rubber) or heat seal connector.
- Except for soldering the interface, do not make any alterations or modifications with a soldering iron.
- Do not drop, bend or twist the LCM.

## 2 Handling precaution for LCM

2.1 LCM is easy to be damaged. Please note below and be careful for handling.

### 2.2 Correct handling:



As above picture, please handle with anti-static gloves around LCM edges.

### 2.3 Incorrect handling:



Please don't touch IC directly.

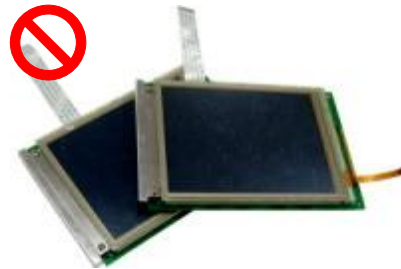

Please don't stack LCM.



Please don't hold the surface of panel.

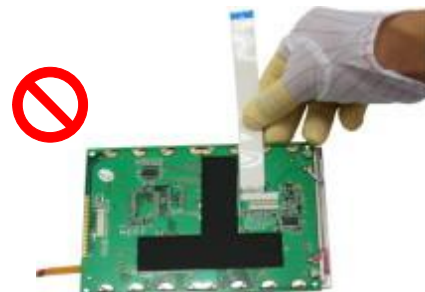

Please don't stretch interface of output, such as FPC cable.



Please don't hold the surface of IC.

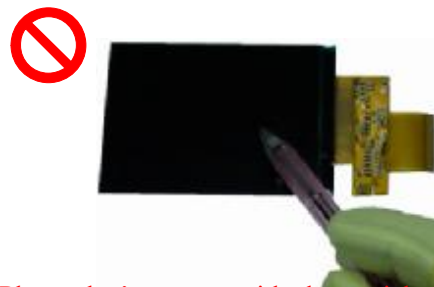

Please don't operate with sharp stick such as pens.

### 3 Storage Precautions

3.1 When storing the LCD modules, the following precaution are necessary.

3.1.1 Store them in a sealed polyethylene bag. If properly sealed, there is no need for the desiccant.

3.1.2 Store them in a dark place. Do not expose to sunlight or fluorescent light, keep the temperature between 0°C and 35°C, and keep the relative humidity between 40%RH and 60%RH.

3.1.3 The polarizer surface should not come in contact with any other objects (We advise you to store them in the anti-static electricity container in which they were shipped).

3.2 Transportation Precautions

3.2.1 During shipment, please handle with care. The packaging bag can not be broken, step on trap. Packaging Carton layer height can not be over two meters.

3.2.2 The transportation process should pay attention to the waterproof and moisture-proof measures. Product can not be watering. Ethylene sealed bags can not be unsealed.

3.3 Others

3.3.1 Liquid crystals solidify under low temperature (below the storage temperature range) leading to defective orientation or the generation of air bubbles (black or white). Air bubbles may also be generated if the module is subject to a low temperature.

3.3.2 If the LCD modules have been operating for a long time showing the same display patterns, the display patterns may remain on the screen as ghost images and a slight contrast irregularity may also appear. A normal operating status can be regained by suspending use for some time. It should be noted that this phenomenon does not adversely affect performance reliability.

3.3.3 To minimize the performance degradation of the LCD modules resulting from destruction caused by static electricity etc., exercise care to avoid holding the following sections when handling the modules.

3.3.3.1 - Exposed area of the printed circuit board.

3.3.3.2 -Terminal electrode sections.

### 4 USING LCD MODULES

4.1 Installing LCD Modules

The hole in the printed circuit board is used to fix LCM as shown in the picture below. Attend to the following items when installing the LCM.

4.1.1 Cover the surface with a transparent protective plate to protect the polarizer and LC cell.

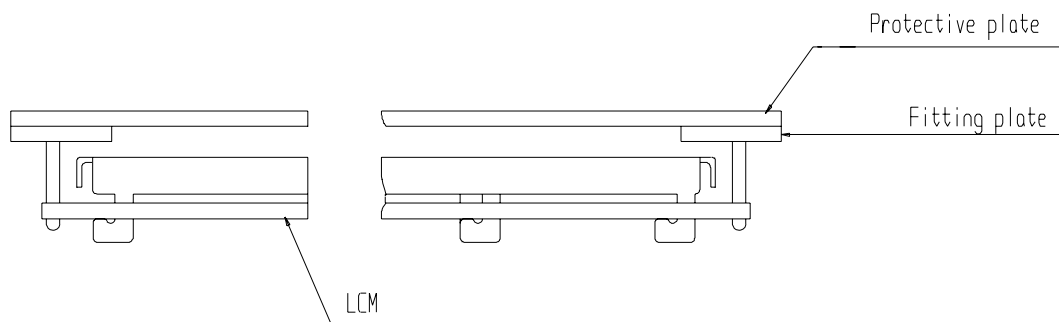

4.1.2 When assembling the LCM into other equipment, the spacer to the bit between the LCM and the fitting plate should have enough height to avoid causing stress to the module surface, refer to the individual specifications for measurements. The measurement tolerance should be  $\pm 0.1\text{mm}$

4.2 Precaution for assemble the module with BTB connector:

Please note the position of the male and female connector position, don't assemble or assemble like the method which the following picture shows

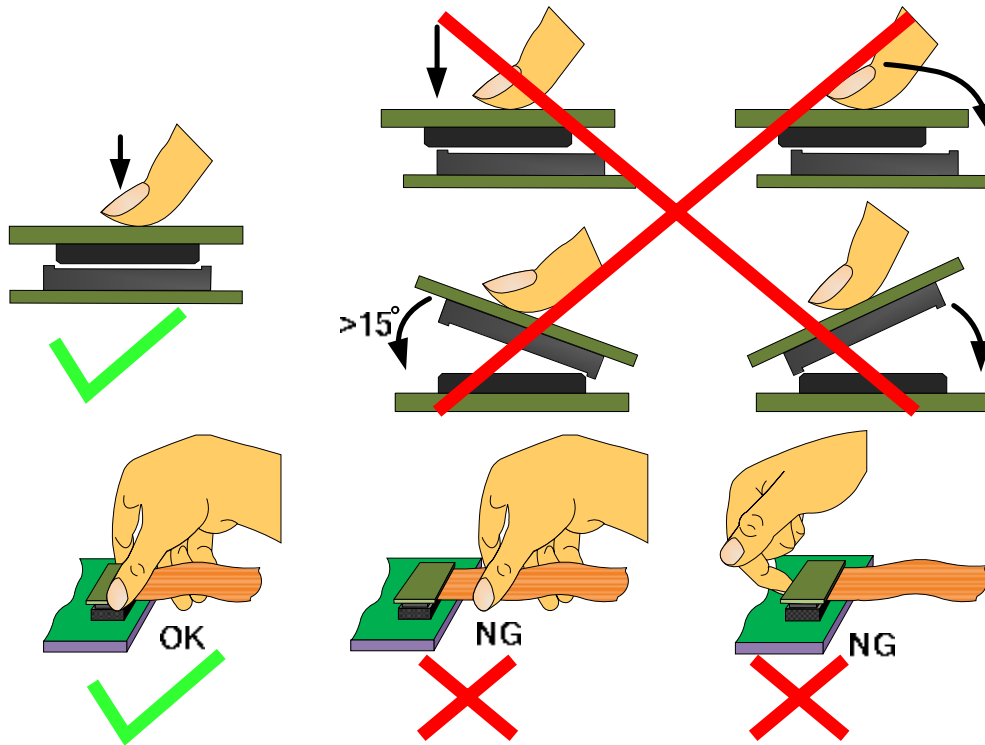

### 4.3 Precaution for soldering the LCM

	Manual soldering	Machine drag soldering	Machine press soldering
No RoHS Product	290°C ~350°C. Time : 3-5S.	330°C ~350°C. Speed : 4-8 mm/s.	300°C ~330°C. Time : 3-6S. Press: 0.8~1.2Mpa
RoHS Product	340°C ~370°C. Time : 3-5S.	350°C ~370°C. Time : 4-8 mm/s.	330°C ~360°C. Time : 3-6S. Press: 0.8~1.2Mpa

4.3.1 If soldering flux is used, be sure to remove any remaining flux after finishing to soldering operation (This does not apply in the case of a non-halogen type of flux). It is recommended that you protect the LCD surface with a cover during soldering to prevent any damage due to flux spatters

4.3.2 When soldering the electroluminescent panel and PC board, the panel and board should not be detached more than three times. This maximum number is determined by the temperature and time conditions mentioned above, though there may be some variance depending on the temperature of the soldering iron.

4.3.3 When remove the electroluminescent panel from the PC board, be sure the solder has completely melted, the soldered pad on the PC board could be damaged.

### 4.4 Precautions for Operation

4.4.1 Viewing angle varies with the change of liquid crystal driving voltage (VLCD). Adjust VLCD to show the best contrast.

4.4.2 It is an indispensable condition to drive LCD s within the specified voltage limit since the higher voltage then the limit cause the shorter LCD life. An electrochemical reaction due to direct current causes LCD's undesirable deterioration, so that the use of direct current drive should be avoided

4.4.3 Response time will be extremely delayed at lower temperature than the operating temperature range and on the other hand at higher temperature LCD's show dark color in them. However those phenomena do not mean malfunction or out of order with LCD's, which will come back in the specified operating temperature.

4.4.4 If the display area is pushed hard during operation, the display will become abnormal. However, it will return to normal if it is turned off and then back on.

4.4.5 A slight dew depositing on terminals is a cause for electro-chemical reaction resulting in terminal open circuit. Usage under the maximum operating temperature, 50%RH or less is required

4.4.6 Input logic voltage before apply analog high voltage such as LCD driving voltage when power on. Remove analog high voltage before logic voltage when power off the module. Input each signal after the positive/negative voltage becomes stable.

4.4.7 Please keep the temperature within the specified range for use and storage. Polarization degradation, bubble generation or polarizer peel-off may occur with high temperature and high humidity

### 4.5 Safety

4.5.1 It is recommended to crush damaged or unnecessary LCDs into pieces and wash them off with solvents such as acetone and ethanol which should later be burned

4.5.2 If any liquid leaks out of a damaged glass cell and comes in contact with the hands, wash off thoroughly with soap and water



#### 4.6 Limited Warranty

Unless agreed between Multi-Inno and the customer Multi-Inno will replace or repair any of its LCD modules which are found to be functionally defective when inspected in accordance with Multi-Inno LCD acceptance standards (copies available upon request) for a period of one year from date of production. Cosmetic/visual defects must be returned to Multi-Inno within 90 days of shipment. Confirmation of such date shall be based on data code on product. The warranty liability of Multi-Inno limited to repair and/or replace on the terms set forth above. Multi-Inno will not be responsible for any subsequent or consequential events.

#### 4.7 Return LCM under warranty

4.7.1 No warranty can be granted if the precautions stated above have been disregarded. The typical examples of violations are :

4.7.1.1 - Broken LCD glass.

4.7.1.2 - PCB eyelet is damaged or modified.

4.7.1.3 -PCB conductors damaged.

4.7.1.4 - Circuit modified in any way, including addition of components.

4.7.1.5 - PCB tampered with by grinding, engraving or painting varnish.

4.7.1.6 - Soldering to or modifying the bezel in any manner.

4.7.2 Module repairs will be invoiced to the customer upon mutual agreement. Modules must be returned with sufficient description of the failures or defects. Any connectors or cable installed by the customer must be removed completely without damaging the PCB eyelet, conductors and terminals.

### **PACKING SPECIFICATION**

Please consult our technical department for detail information.

### **PRIOR CONSULT MATTER**

- 1 For Multi-Inno standard products, we keep the right to change material, process ... for improving the product property without prior notice to our customer.
- 2 For OEM products, if any changes are needed which may affect the product property, we will consult with our customer in advance.
- 3 If you have special requirement about reliability condition, please let us know before you start the test on our samples.