



MULTI-INNO TECHNOLOGY CO., LTD.

www.multi-inno.com

LCD MODULE SPECIFICATION

Model : MI0350A1T-4

This module uses ROHS material

For Customer's Acceptance:

| | |
|----------|--|
| Customer | |
| Approved | |
| Comment | |

This specification may change without prior notice in order to improve performance or quality. Please contact Multi-Inno for updated specification and product status before design for this product or release of this order.

| | |
|---------------|------------|
| Revision | 1.0 |
| Engineering | |
| Date | 2013-11-10 |
| Our Reference | |



REVISION RECORD

| REV NO. | REV DATE | CONTENTS | REMARKS |
|----------------|-----------------|-----------------|----------------|
| 1.0 | 2013-11-10 | First Release | |
| | | | |
| | | | |
| | | | |
| | | | |
| | | | |
| | | | |
| | | | |
| | | | |
| | | | |
| | | | |
| | | | |
| | | | |
| | | | |
| | | | |
| | | | |
| | | | |
| | | | |
| | | | |
| | | | |
| | | | |

CONTENTS

- GENERAL INFORMATION
- EXTERNAL DIMENSIONS
- ABSOLUTE MAXIMUM RATINGS
- ELECTRICAL CHARACTERISTICS
- BACKLIGHT CHARACTERISTICS
- ELECTRO-OPTICAL CHARACTERISTICS
- INTERFACE DESCRIPTION
- BLOCK DIAGRAM
- APPLICATION NOTES
- RELIABILITY TEST
- INSPECTION CRITERION
- PRECAUTIONS FOR USING LCD MODULES
- PRIOR CONSULT MATTER

■ GENERAL INFORMATION

| Item | Contents | Unit |
|--------------------------------|------------------------------------------------------------|-----------------|
| LCD type | TFT/Negative/Transmissive/Normally white | / |
| Size | 3.5 | Inch |
| Viewing direction | 12:00(without image inversion and least brightness change) | O' Clock |
| Gray scale inversion direction | 6:00(contrast peak located at) | O' Clock |
| LCM (W × H × D) | 93.50×66.44 ×8.56 | mm ³ |
| Active area (W×H) | 70.08×52.56 | mm ² |
| Dot pitch (W×H) | 0.073×0.219 | mm ² |
| Number of dots | 320 (RGB) × 240 | / |
| Driver IC | SSD1963 | / |
| Backlight type | 6 LEDs | / |
| Interface type | 8-bit MPU | / |
| Color depth | 262K | / |
| Input voltage | 3.3 | V |
| With/Without TSP | With TSP | / |
| Weight | TBD | g |

Note 1: RoHS compliant

Note 2: LCM weight tolerance: ± 5% .

EXTERNAL DIMENSIONS

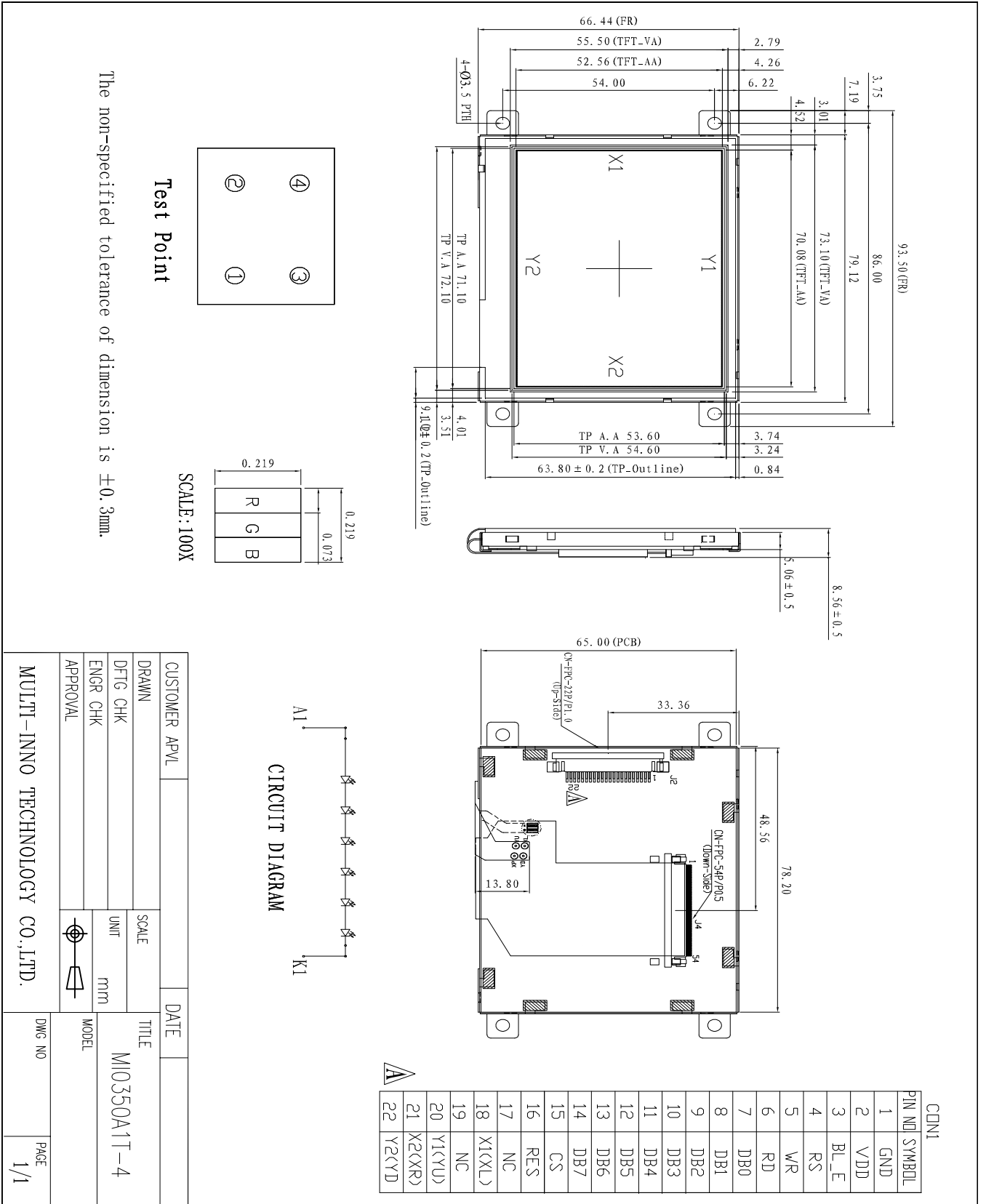

■ TOUCH PANEL INFORMATION

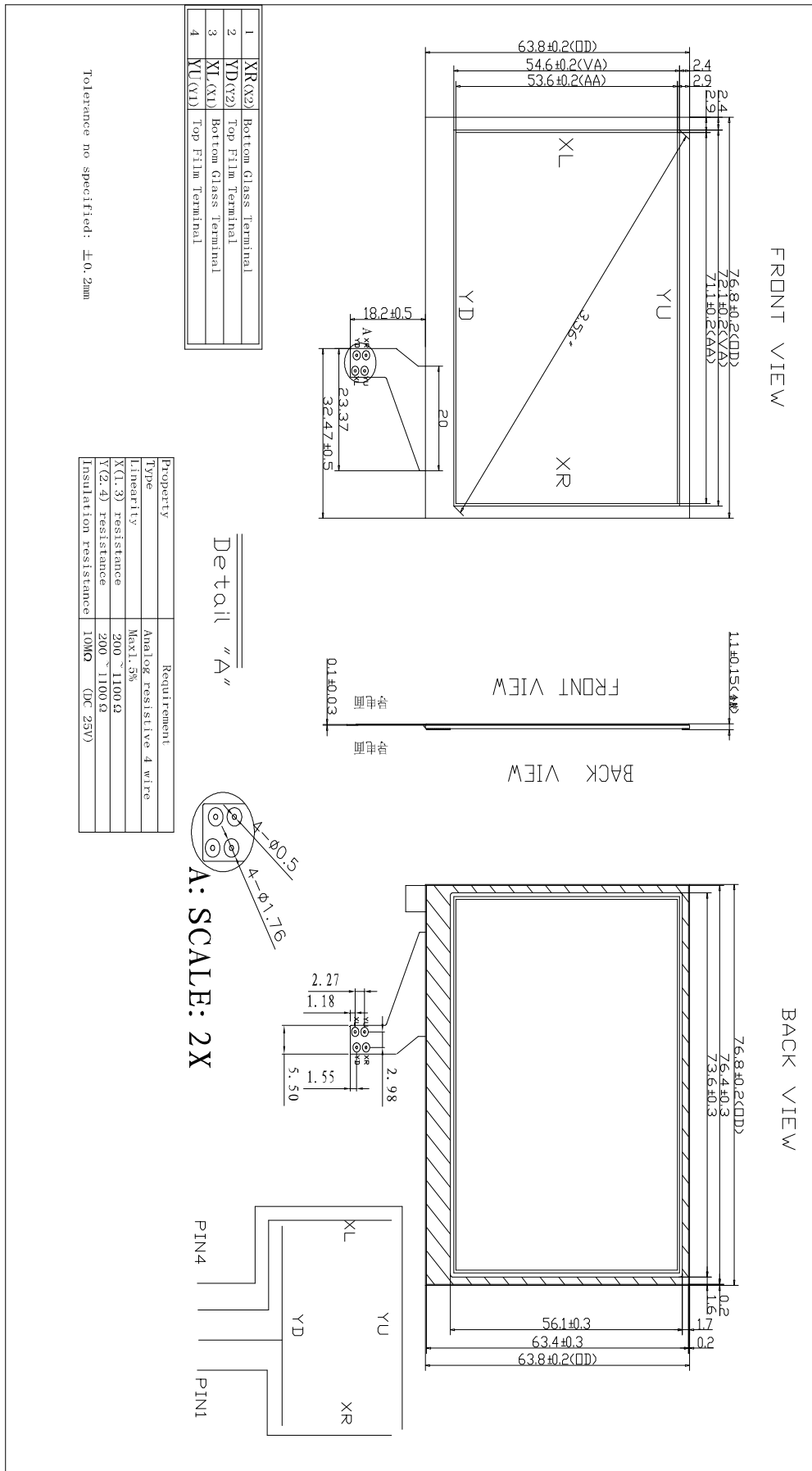

■ ABSOLUTE MAXIMUM RATINGS

| Parameter | Symbol | Min | Max | Unit |
|-----------------------|----------|-----|--------------|------|
| Operating temperature | T_{OP} | -20 | 70 | °C |
| Storage temperature | T_{ST} | -30 | 80 | °C |
| Humidity | RH | - | 90%(Max60°C) | RH |

■ ELECTRICAL CHARACTERISTICS

| Parameter | Symbol | Min | Typ | Max | Unit |
|---------------------------|----------|--------|-----|--------|------|
| Supply voltage for logic | VDD | 3.0 | 3.3 | 3.6 | V |
| Power supply for current | IDD | - | 161 | 240 | mA |
| Input voltage ' H ' level | V_{IH} | 0.7VDD | - | VDD | V |
| Input voltage ' L ' level | V_{IL} | 0 | - | 0.3VDD | V |

■ BACKLIGHT CHARACTERISTICS

| Item | Symbol | Min. | Typ. | Max. | Unit | Condition |
|-------------------|-----------|------|--------|------|------|------------|
| LED current | I_{LED} | - | 20 | - | mA | |
| LED voltage | V_{LED} | 17.4 | 19.2 | 20.4 | V | Note 1 |
| Power consumption | W_{LED} | - | 384 | 408 | mW | |
| LED life time | - | - | 50,000 | - | Hrs | Note 2,3,4 |

Note 1 : There are 1 Groups LED

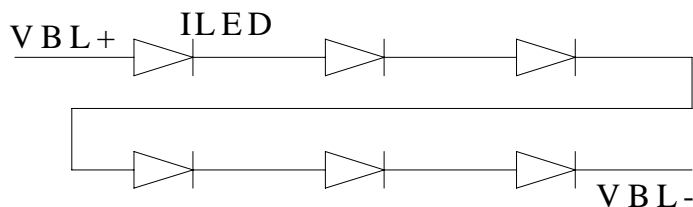

Note 2 : $T_a = 25\text{ }^\circ\text{C}$

Note 3 : Brightness to be decreased to 50% of the initial value

Note 4 : The single LED lamp case

■ELECTRO-OPTICAL CHARACTERISTICS

| Item | Symbol | Condition | Min | Typ | Max | Unit | Remark | Note |
|-------------------------|-------------------|---------------------------------------------------------------------|------|------|------|-------------------|--------|------|
| Response time | Tr+Tf | $\theta=0^\circ$ $\varnothing=0^\circ$ $T_a=25^\circ\text{C}$ | - | 25 | - | ms | FIG 1. | 4 |
| Contrast ratio | Cr | | 300 | 350 | - | --- | FIG 2. | 1 |
| Luminance uniformity | δ WHITE | | - | TBD | - | % | FIG 2. | 3 |
| Surface Luminance | Lv | | 250 | 290 | - | cd/m ² | FIG 2. | 2 |
| Viewing angle range | θ | $\varnothing = 90^\circ$ | 40 | 50 | - | deg | FIG 3. | 6 |
| | | $\varnothing = 270^\circ$ | 45 | 55 | - | deg | FIG 3. | |
| | | $\varnothing = 0^\circ$ | 50 | 60 | - | deg | FIG 3. | |
| | | $\varnothing = 180^\circ$ | 50 | 60 | - | deg | FIG 3. | |
| CIE (x, y) chromaticity | Red | x | - | - | - | FIG 2. | 5 | |
| | | y | - | - | - | | | |
| | Green | x | - | - | - | | | |
| | | y | - | - | - | | | |
| | Blue | x | - | - | - | | | |
| | | y | - | - | - | | | |
| | White | x | 0.26 | 0.31 | 0.36 | | | |
| | | y | 0.28 | 0.33 | 0.38 | | | |

Note 1. Contrast Ratio(CR) is defined mathematically as For more information see FIG 2.

$$\text{Contrast Ratio} = \frac{\text{Average Surface Luminance with all white pixels (P1, P2, P3, P4, P5)}}{\text{Average Surface Luminance with all black pixels (P1, P2, P3, P4, P5)}}$$

Note 2. Surface luminance is the LCD surface from the surface with all pixels displaying white. For more information see FIG 2.

$$L_v = \text{Average Surface Luminance with all white pixels (P1, P2, P3, P4, P5)}$$

Note 3. The uniformity in surface luminance , δ WHITE is determined by measuring luminance at each test position 1 through 5, and then dividing the maximum luminance of 5 points luminance by minimum luminance of 5 points luminance. For more information see FIG 2.

$$\delta \text{ WHITE} = \frac{\text{Minimum Surface Luminance with all white pixels (P1, P2, P3, P4, P5)}}{\text{Maximum Surface Luminance with all white pixels (P1, P2, P3, P4, P5)}}$$

Note 4. Response time is the time required for the display to transition from White to black(Rise Time, Tr) and from black to white(Decay Time, Tf). For additional information see FIG 1. The test equipment is Autronic-Melchers's ConoScope. Series.

Note 5. CIE (x, y) chromaticity, The x, y value is determined by measuring luminance at each test position 1 through 5, and then make average value.

Note 6. Viewing angle is the angle at which the contrast ratio is greater than 2. For TFT module the contrast ratio is greater than 10. The angles are determined for the horizontal or x axis and the vertical or y axis with respect to the z axis which is normal to the LCD surface. For more information see FIG 3.

Note 7. For viewing angle and response time testing, the testing data is base on Autronic-Melchers's ConoScope. Series Instruments For contrast ratio, Surface Luminance, Luminance uniformity, CIE The test data is base on TOPCON's BM-5 photo detector.

FIG. 1 The definition of Response Time

The response time is defined as the following figure and shall be measured by switching the input signal for “black” and “white”.

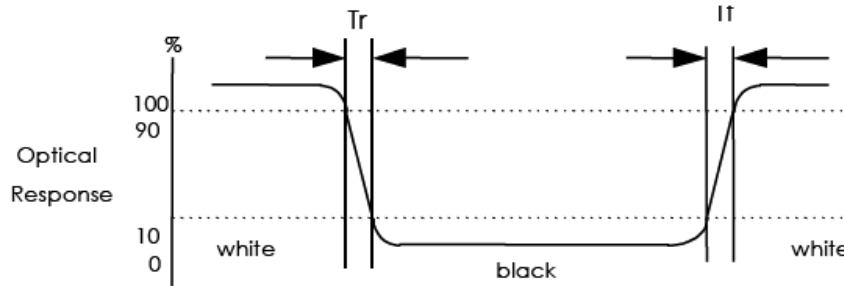

FIG. 2 Measuring method for Contrast ratio, surface luminance, Luminance uniformity , CIE (x, y) chromaticity

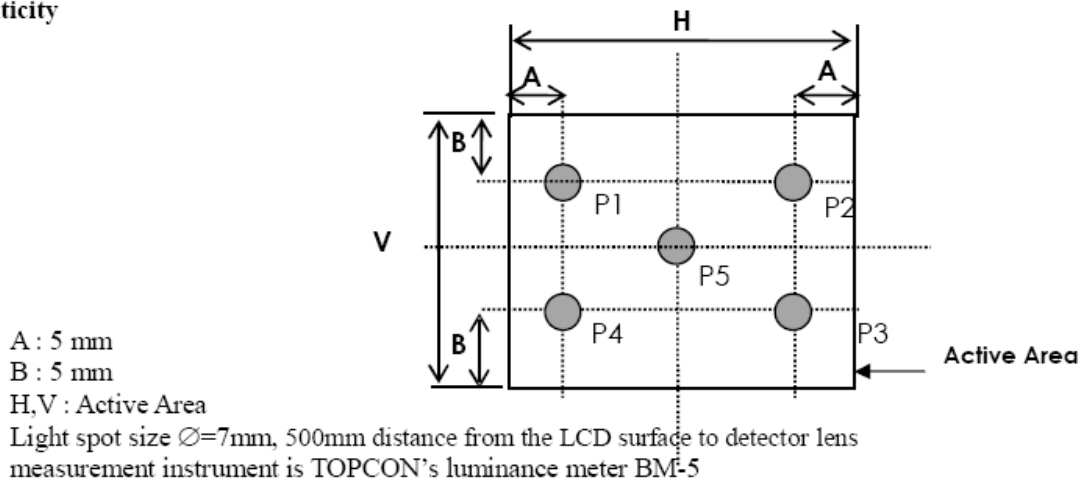
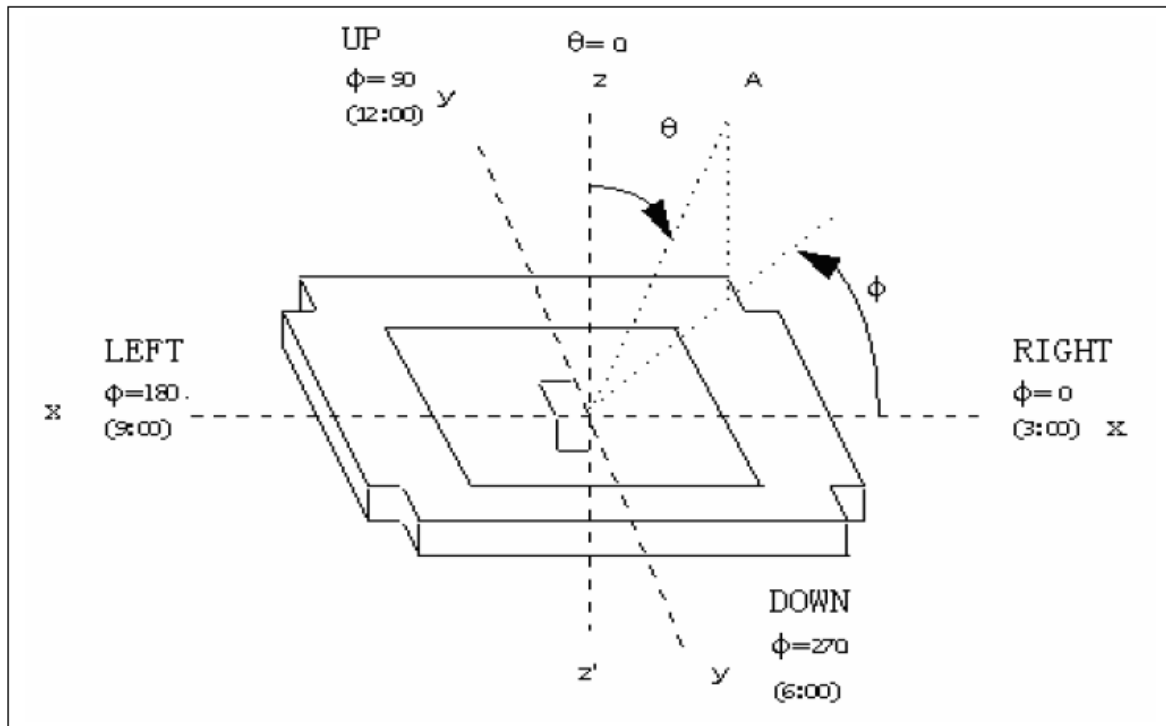

FIG. 3 The definition of viewing angle



**■ INTERFACE DESCRIPTION**

| Pin | Symbol | Function | Remark |
|-----|--------|-----------------------------------------------------------|--------|
| 1 | GND | System ground pin of the IC. Connect to system ground. | |
| 2 | VDD | Power Supply : +3.3V | |
| 3 | BL_E | Backlight control signal , H: On \ L:Off | |
| 4 | D/C | Data/Command select | |
| 5 | WR | Write strobe signal | |
| 6 | RD | Read strobe signal | |
| 7 | DB0 | Data bus | |
| 8 | DB1 | Data bus | |
| 9 | DB2 | Data bus | |
| 10 | DB3 | Data bus | |
| 11 | DB4 | Data bus | |
| 12 | DB5 | Data bus | |
| 13 | DB6 | Data bus | |
| 14 | DB7 | Data bus | |
| 15 | CS | Chip select | |
| 16 | RESET | Hardware reset | |
| 17 | NC | No connect | |
| 18 | X1(XL) | Left electrode | |
| 19 | NC | No connect | |
| 20 | Y1(YU) | Top electrode | |
| 21 | X2(LR) | Right electrode | |
| 22 | Y2(YD) | Down electrode | |

■ BLOCK DIAGRAM

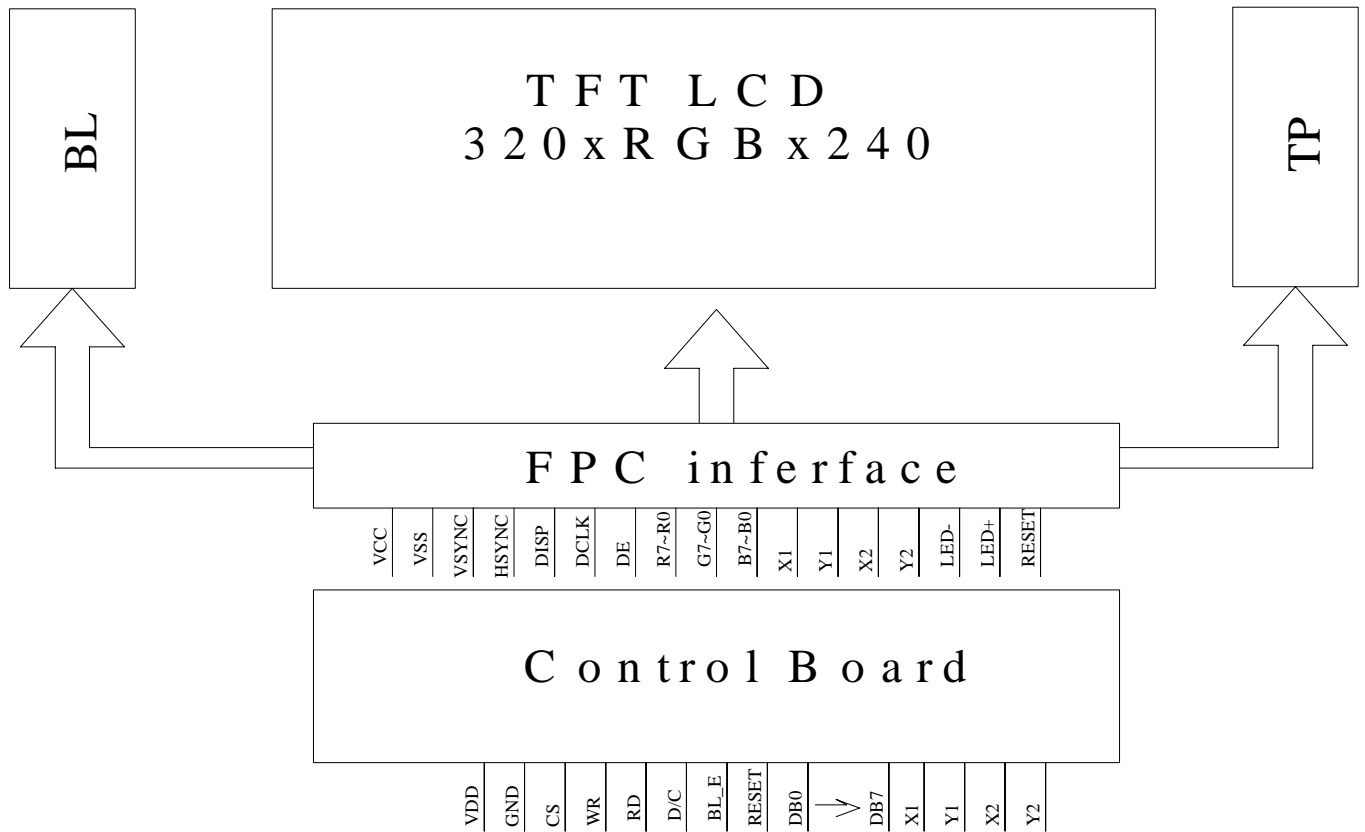

■ APPLICATION NOTES

1. Interface Timing

1.1 8080 Mode

The 8080 mode MCU interface consist of CS#, D/C#, RD#, WR#, D[23:0] and TE signals (Please refer to Table 6-1 for pin multiplexed with 6800 mode). This interface use WR# to define a write cycle and RD# for read cycle. If the WR# goes low when the CS# signal is low, the data or command will be latched into the system at the rising edge of WR#. Similarly, the read cycle will start when RD# goes low and end at the rising edge of RD#.

1.2 8080 Mode Write Cycle

| Symbol | Parameter | Min | Typ | Max | Unit |
|-------------|----------------------------|-----|-----|-----|-----------|
| t_{cyc} | Reference Clock Cycle Time | 9 | - | - | ns |
| t_{PWCSL} | Pulse width CS# low | 1 | - | - | t_{cyc} |
| t_{PWCSH} | Pulse width CS# high | 1 | - | - | t_{cyc} |
| t_{FDRD} | First Read Data Delay | 5 | - | - | t_{cyc} |
| t_{AS} | Address Setup Time | 1 | - | - | ns |
| t_{AH} | Address Hold Time | 1 | - | - | ns |
| t_{DSW} | Data Setup Time | 4 | - | - | ns |
| t_{DHW} | Data Hold Time | 1 | - | - | ns |
| t_{DSR} | Data Access Time | - | - | 5 | ns |
| t_{DHR} | Output Hold Time | 1 | - | - | ns |

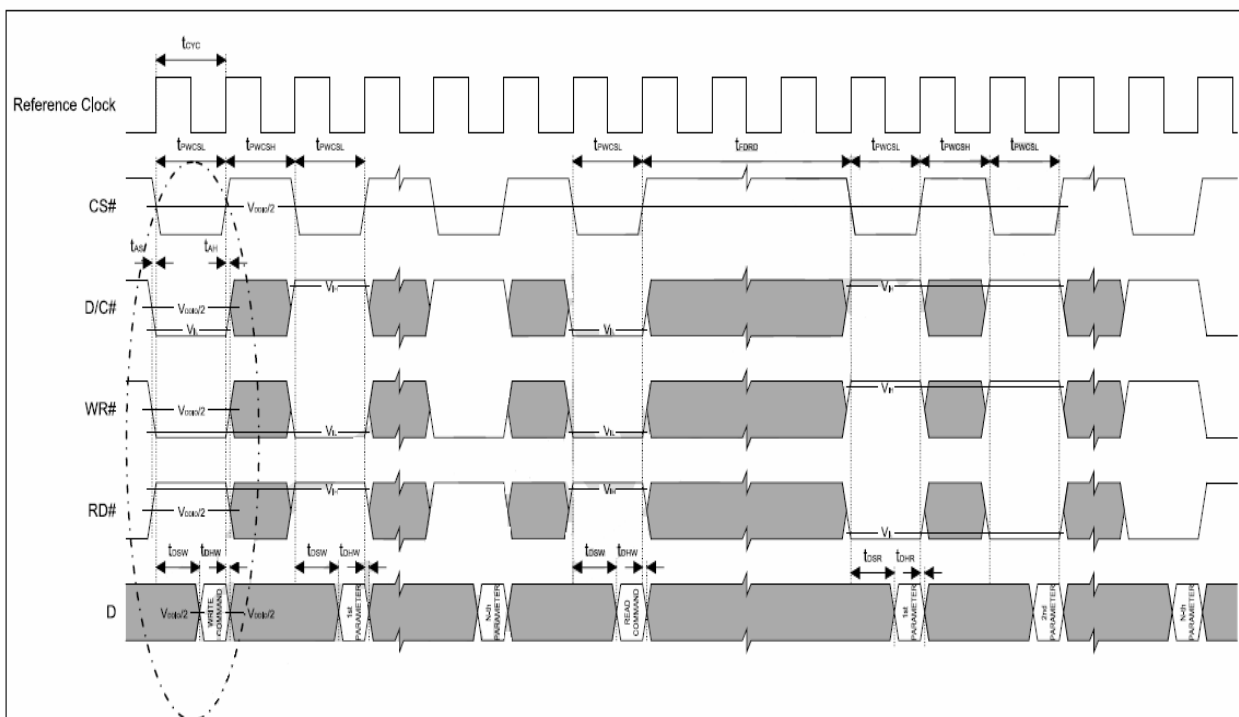

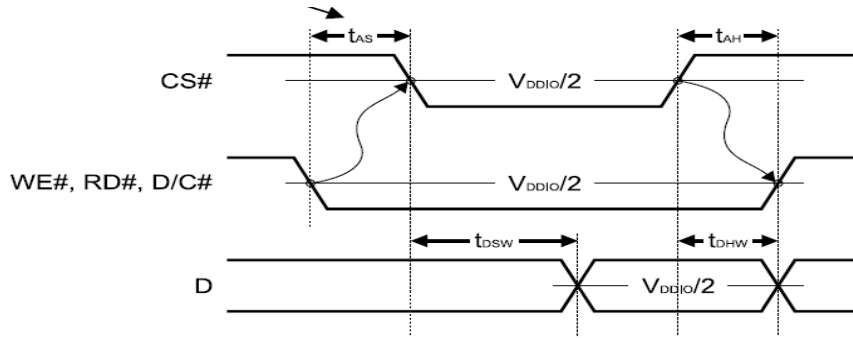

1.3 Pixel Data Format

| Interface | Cycle | D[23] | D[22] | D[21] | D[20] | D[19] | D[18] | D[17] | D[16] | D[15] | D[14] | D[13] | D[12] | D[11] | D[10] | D[9] | D[8] | D[7] | D[6] | D[5] | D[4] | D[3] | D[2] | D[1] | D[0] |
|----------------------|-----------------|-------|-------|-------|-------|-------|-------|-------|-------|-------|-------|-------|-------|-------|-------|------|------|------|------|------|------|------|------|------|------|
| 24 bits | 1 st | R7 | R6 | R5 | R4 | R3 | R2 | R1 | R0 | G7 | G6 | G5 | G4 | G3 | G2 | G1 | G0 | B7 | B6 | B5 | B4 | B3 | B2 | B1 | B0 |
| 18 bits | 1 st | | | | | | | R5 | R4 | R3 | R2 | R1 | R0 | G5 | G4 | G3 | G2 | G1 | G0 | B5 | B4 | B3 | B2 | B1 | B0 |
| 16 bits (565 format) | 1 st | | | | | | | | | R5 | R4 | R3 | R2 | R1 | G5 | G4 | G3 | G2 | G1 | G0 | B5 | B4 | B3 | B2 | B1 |
| 16 bits | 1 st | | | | | | | | | R5 | R4 | R3 | R2 | R1 | R0 | X | X | G5 | G4 | G3 | G2 | G1 | G0 | X | X |
| | 2 nd | | | | | | | | | B5 | B4 | B3 | B2 | B1 | B0 | X | X | R5 | R4 | R3 | R2 | R1 | R0 | X | X |
| | 3 rd | | | | | | | | | G5 | G4 | G3 | G2 | G1 | G0 | X | X | B5 | B4 | B3 | B2 | B1 | B0 | X | X |
| 9 bits | 1 st | | | | | | | | | | | | | | | | R5 | R4 | R3 | R2 | R1 | R0 | G5 | G4 | G3 |
| | 2 nd | | | | | | | | | | | | | | | | G2 | G1 | G0 | B5 | B4 | B3 | B2 | B1 | B0 |
| 8 bits | 1 st | | | | | | | | | | | | | | | | | R5 | R4 | R3 | R2 | R1 | R0 | X | X |
| | 2 nd | | | | | | | | | | | | | | | | | G5 | G4 | G3 | G2 | G1 | G0 | X | X |
| | 3 rd | | | | | | | | | | | | | | | | | B5 | B4 | B3 | B2 | B1 | B0 | X | X |

X: Don't Care



2. Initial Code For Reference

```
void Initial_SSD1963()
{
    Write_Command(0x01);
    Delay_ms(10);
    Write_Command(0xe0);
    Write_Parameter(0x01);
    Delay_ms(5);
    Write_Command(0xe0);
    Write_Parameter(0x03);
    Delay_ms(5);

    Write_Command(0xb0);
    Write_Parameter(0x0c);
    Write_Parameter(0x80);
    Write_Parameter(0x01);
    Write_Parameter(0x3f);
    Write_Parameter(0x00);
    Write_Parameter(0xef);
    Write_Parameter(0x00);

    Write_Command(0xf0);
    Write_Parameter(0x00);

    Write_Command(0xe2);
    Write_Parameter(0x1d);
    Write_Parameter(0x02);
    Write_Parameter(0x54);

    Write_Command(0xe6);
    Write_Parameter(0x00);
    Write_Parameter(0xdd);
    Write_Parameter(0xde);

    Write_Command(0xb4);
    Write_Parameter(0x01);
    Write_Parameter(0x98);
}
```



```
Write_Parameter(0x00);  
Write_Parameter(0x44);  
Write_Parameter(0x14);  
Write_Parameter(0x00);  
Write_Parameter(0x00);  
Write_Parameter(0x00);
```

```
Write_Command(0xb6);  
Write_Parameter(0x01);  
Write_Parameter(0x06);  
Write_Parameter(0x00);  
Write_Parameter(0x12);  
Write_Parameter(0x04);  
Write_Parameter(0x00);  
Write_Parameter(0x00);
```

```
Write_Command(0x2a);  
Write_Parameter(0x00);  
Write_Parameter(0x00);  
Write_Parameter(0x01);  
Write_Parameter(0x3f);
```

```
Write_Command(0x2b);  
Write_Parameter(0x00);  
Write_Parameter(0x00);  
Write_Parameter(0x00);  
Write_Parameter(0xef);
```

```
Write_Command(0x29);  
Write_Command(0x2c);
```

```
}
```

■ RELIABILITY TEST

| No. | Test Item | Test Condition | Inspection after test |
|-----|----------------------------|-----------------------------------------------------------------------------------------------------------------|-----------------------|
| 1 | High Temperature Storage | $80 \pm 2^{\circ}\text{C}/200$ hours | 2 |
| 2 | Low Temperature Storage | $-30 \pm 2^{\circ}\text{C}/200$ hours | 1,2 |
| 3 | High Temperature Operating | $70 \pm 2^{\circ}\text{C}/200$ hours | |
| 4 | Low Temperature Operating | $-20 \pm 2^{\circ}\text{C}/200$ hours | 1 |
| 5 | Temperature Cycle | $-20 \pm 2^{\circ}\text{C} \sim 25 \sim 70 \pm 2^{\circ}\text{C} \times 10$ cycles (30min.) (5min.) (30min.) | |
| 6 | Damp Proof Test | $60^{\circ}\text{C} \pm 5^{\circ}\text{C} \times 90\% \text{RH}/96$ hours | 1,2 |
| 7 | Vibration Test | Frequency: 10Hz~55Hz Amplitude: 15mm, One cycle 60 seconds to 3 directions of X,Y,Z for each 15 minutes | 3 |
| 8 | ESD | VS=800V,RS=1.5kΩ CS=100pF 1 time | |

Note1: No dew condensation to be observed.

Note2: The function test shall be conducted after 4 hours storage at the normal Temperature and humidity after remove from the test chamber.

Note3: The packing have to including into the vibration testing.

■ INSPECTION CRITERION

1. Inspection Condition

- Sample Plan: MIL-STD-105E LEVEL: II
AQL: Major (MA):0.65%/Minor(MI):1.5%
- Cosmetic inspect 300~500Lux fluorescent light, leaving 30~35cm between panels and eyes ,and between panels and lights.
- Functional in spec under 200 Lux .
- Inspection condition is $23\pm 5^{\circ}\text{C}$, $50\pm 20\% \text{RH}$ maximum.

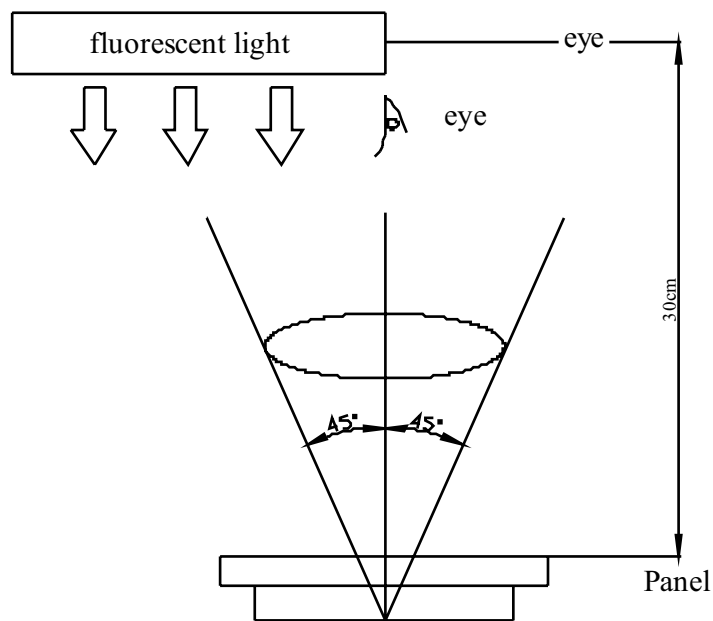

·Definition of area

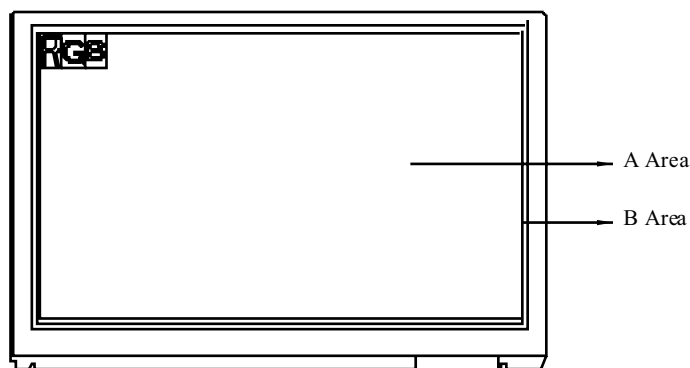

A Area: Viewing area.

B Area: Out of viewing.(Don't care cosmetic in outside viewing area)

2. Inspection specification

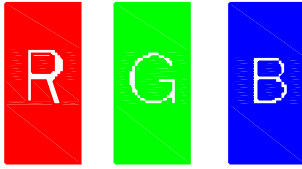
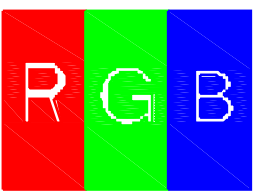
| NO | Item | Acceptable specification | Judgment Criterion |
|----|---------------------------|------------------------------------------------------------------------------------------------------------------------------------------------------------------------------------------------------------------------------------------------------------------------------------------------------------------------------------------------------------------------------------------------------------------------------------------------------------------------------------------------------------------------------------------------------------------------------------------------------------------------------------------------------------------------------------------------------------------------------------------------------------------------------------------------------------------------------------------------------------------------------------------------------------------------------------------------------------------------------------------------------------------------------------------------------------------------------------------------------------------------------------------------------------------------------------------------------------------------------------------------------------------------------------------------------------------------------------------------------------------------------------------------------------------------------------------------------------------------------------------------------------------------------------------------------------------------------------------------------|----------------------------------------------------------|
| 1 | Electrical Testing (MA) | <p>1-1 sub pixel classification</p> <ul style="list-style-type: none"> ● sub pixel: Number of sub pixel doesn't exceed Five dot. <div style="text-align: center;">  <p>Sub Pixel(Dot)</p> </div> <p>a>Dark dot ----Four Allowed b>Bright dot---one Allowed c>The definition of dot ----The size of a defective dot over 1/2 of whole dot is regarded as one defective dot. d> Dark sub pixel: The distance more than 5mm between dot and dot. e>Bright sub pixel: The distance more than 20mm between bright dot and bright dot .</p> <ul style="list-style-type: none"> ● Pixel : Three dots link together-----one allowed. <div style="text-align: center;">  <p>Pixel</p> </div> <p>1-2Leakage to light</p> <ul style="list-style-type: none"> ● Leakage to light be not allowed. <p>1-3 Picture to shake</p> <ul style="list-style-type: none"> ● Picture had shake ,twinkle and noise etc. instable of defect that be not allowed. <p>1-4 Function</p> <ul style="list-style-type: none"> ● No display or No function is not allowed. ● Source Line, Gate Line is not allowed. ● Contrast Ratio exceeds product specifications. ● Current consumption exceeds product specifications. ● Display malfunction. | <p>N≤4 N≤1</p> <p>N≤1</p> <p>N=0 N=0 N=0</p> |
| 02 | Mechanical Dimension(M A) | <p>2.1 Mechanical Dimension exceeds product specifications.</p> <p>2-2 Out of frame and boss of plastic changed shape that be not allowed.</p> | N=0 |

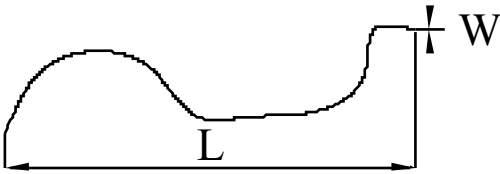
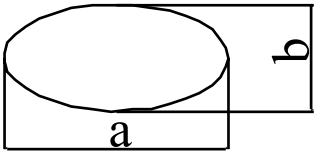
| NO | Item | Acceptable specification | Judgment Criterion | | | | | | | | | | | | | | | | | | | | | | | |
|------------------------------------------------------------------------------------------------------------------------------------------------------------------------------------------------------------------------------------------------------------------------------------------------------------------------------------------------------------------------------------------------------------------------------------|--------------------------|------------------------------------------------------------------------------------------------------------------------------------------------------------------------------------------------------------------------------------------------------------------------------------------------------------------------------------------------------------------------------------------------------------------------------------------------------------------------------------------------------------------------------------------------------------------------------------------------------------------------------------------------------------------------------------------------------------------------------------------------------------------------------------------------------------------------------------------------|---------------------|-------------------|-------------------|-------------------|-----------------------|------|-----------------------|--------------|-----|--------------|------------|---------------------|---|---|------|-----------|-------------|-----|-------------|---------|------|-------------|-------------|-----|
| 3 | Cosmetic Inspection (MA) | <p>3-1 Fiber / Line shapes of defect</p> <table border="1" data-bbox="400 344 1249 694"> <thead> <tr> <th>Length</th> <th>Width</th> <th>Acceptable number</th> <th>Mini. space</th> <th>Acceptable number</th> </tr> </thead> <tbody> <tr> <td>----</td> <td>$W \leq 0.05$</td> <td>Ignore</td> <td rowspan="2">5mm</td> <td>Ignore</td> </tr> <tr> <td>$L \leq 3$</td> <td>$0.05 < W \leq 0.1$</td> <td>3</td> <td>3</td> </tr> <tr> <td>----</td> <td>$W > 0.1$</td> <td>Not allowed</td> <td rowspan="2">---</td> <td>Not allowed</td> </tr> <tr> <td>$L > 3$</td> <td>----</td> <td>Not allowed</td> <td>Not allowed</td> </tr> </tbody> </table> <p>L: length(mm) W: width(mm)</p>  | Length | Width | Acceptable number | Mini. space | Acceptable number | ---- | $W \leq 0.05$ | Ignore | 5mm | Ignore | $L \leq 3$ | $0.05 < W \leq 0.1$ | 3 | 3 | ---- | $W > 0.1$ | Not allowed | --- | Not allowed | $L > 3$ | ---- | Not allowed | Not allowed | 2.5 |
| | | Length | Width | Acceptable number | Mini. space | Acceptable number | | | | | | | | | | | | | | | | | | | | |
| | | ---- | $W \leq 0.05$ | Ignore | 5mm | Ignore | | | | | | | | | | | | | | | | | | | | |
| | | $L \leq 3$ | $0.05 < W \leq 0.1$ | 3 | | 3 | | | | | | | | | | | | | | | | | | | | |
| | | ---- | $W > 0.1$ | Not allowed | --- | Not allowed | | | | | | | | | | | | | | | | | | | | |
| | | $L > 3$ | ---- | Not allowed | | Not allowed | | | | | | | | | | | | | | | | | | | | |
| | | <p>3-2 Blemish: dot shapes of defect.</p> <table border="1" data-bbox="416 1064 1187 1265"> <thead> <tr> <th>Dimension</th> <th>Acceptable number</th> <th>Mini. space</th> </tr> </thead> <tbody> <tr> <td>$\Phi \leq 0.2$</td> <td>Ignore</td> <td>---</td> </tr> <tr> <td>$0.2 < \Phi \leq 0.3$</td> <td>3</td> <td>5mm</td> </tr> <tr> <td>$\Phi > 0.3$</td> <td>0</td> <td>----</td> </tr> </tbody> </table> | Dimension | Acceptable number | Mini. space | $\Phi \leq 0.2$ | Ignore | --- | $0.2 < \Phi \leq 0.3$ | 3 | 5mm | $\Phi > 0.3$ | 0 | ---- | | | | | | | | | | | | |
| | | Dimension | Acceptable number | Mini. space | | | | | | | | | | | | | | | | | | | | | | |
| | | $\Phi \leq 0.2$ | Ignore | --- | | | | | | | | | | | | | | | | | | | | | | |
| | | $0.2 < \Phi \leq 0.3$ | 3 | 5mm | | | | | | | | | | | | | | | | | | | | | | |
| $\Phi > 0.3$ | 0 | ---- | | | | | | | | | | | | | | | | | | | | | | | | |
| <p>3-3 Bubble</p> <table border="1" data-bbox="416 1350 1187 1552"> <thead> <tr> <th>Dimension</th> <th>Acceptable number</th> <th>Mini. space</th> </tr> </thead> <tbody> <tr> <td>$\Phi \leq 0.20$</td> <td>Ignore</td> <td>---</td> </tr> <tr> <td>$0.2 < \Phi \leq 0.3$</td> <td>3</td> <td>15mm</td> </tr> <tr> <td>$\Phi > 0.3$</td> <td>0</td> <td>----</td> </tr> </tbody> </table> | Dimension | Acceptable number | Mini. space | $\Phi \leq 0.20$ | Ignore | --- | $0.2 < \Phi \leq 0.3$ | 3 | 15mm | $\Phi > 0.3$ | 0 | ---- | | | | | | | | | | | | | | |
| Dimension | Acceptable number | Mini. space | | | | | | | | | | | | | | | | | | | | | | | | |
| $\Phi \leq 0.20$ | Ignore | --- | | | | | | | | | | | | | | | | | | | | | | | | |
| $0.2 < \Phi \leq 0.3$ | 3 | 15mm | | | | | | | | | | | | | | | | | | | | | | | | |
| $\Phi > 0.3$ | 0 | ---- | | | | | | | | | | | | | | | | | | | | | | | | |
| <p>Foreign Substances</p>  <p>$\Phi = (a + b) / 2$</p> | | | | | | | | | | | | | | | | | | | | | | | | | | |

| NO | Item | Acceptable specification | Judgment Criterion | | | | | | | | | | | | | | | | | | | | |
|------------|-------------------------|----------------------------------------------------------------------------------------------------------------------------------------------------------------------------------------------------------------------------------------------------------------------------------------------------------------------------------------------------------------------------------------------------------------------------------------------------------------------------------------------------------------------------------------------------------------------------------------------------------------------------------------------------------------------------------------------------------------|--------------------|-------|-------------------|-------------|------|---------------|--------|-----|------------|---------------------|---|--|------|-----------|-------------|-----|---------|------|-------------|--|--|
| 3 | Cosmetic Inspection(MA) | 3-4 Scratch ● Impassive scratch as below. <table border="1" data-bbox="464 367 1331 645"> <thead> <tr> <th>Length</th> <th>Width</th> <th>Acceptable number</th> <th>Mini. space</th> </tr> </thead> <tbody> <tr> <td>----</td> <td>$W \leq 0.05$</td> <td>Ignore</td> <td>5mm</td> </tr> <tr> <td>$L \leq 3$</td> <td>$0.05 < W \leq 0.1$</td> <td>3</td> <td></td> </tr> <tr> <td>----</td> <td>$W > 0.1$</td> <td>Not allowed</td> <td>---</td> </tr> <tr> <td>$L > 3$</td> <td>----</td> <td>Not allowed</td> <td></td> </tr> </tbody> </table> 3-5 Newton Ring ● $D \leq 8\text{mm}$ ----allowed ● $D \geq 8\text{mm}$ ----NG | Length | Width | Acceptable number | Mini. space | ---- | $W \leq 0.05$ | Ignore | 5mm | $L \leq 3$ | $0.05 < W \leq 0.1$ | 3 | | ---- | $W > 0.1$ | Not allowed | --- | $L > 3$ | ---- | Not allowed | | |
| Length | Width | Acceptable number | Mini. space | | | | | | | | | | | | | | | | | | | | |
| ---- | $W \leq 0.05$ | Ignore | 5mm | | | | | | | | | | | | | | | | | | | | |
| $L \leq 3$ | $0.05 < W \leq 0.1$ | 3 | | | | | | | | | | | | | | | | | | | | | |
| ---- | $W > 0.1$ | Not allowed | --- | | | | | | | | | | | | | | | | | | | | |
| $L > 3$ | ---- | Not allowed | | | | | | | | | | | | | | | | | | | | | |
| 4 | Crack/Break(MA) | Not Allowed. | N=0 | | | | | | | | | | | | | | | | | | | | |
| 5 | Package (MI) | 5-1 Mixed product types 5-2 Shipping q'ty should be the same as "shipping notice form" q'ty. 5-3 Outer box can't broken . | N=0 | | | | | | | | | | | | | | | | | | | | |

■ PRECAUTIONS FOR USING LCD MODULES

Handling Precautions

(1) The display panel is made of glass and polarizer. As glass is fragile. It tends to become or chipped during handling especially on the edges. Please avoid dropping or jarring. Do not subject it to a mechanical shock by dropping it or impact.

(2) If the display panel is damaged and the liquid crystal substance leaks out, be sure not to get any in your mouth. If the substance contacts your skin or clothes, wash it off using soap and water.

(3) Do not apply excessive force to the display surface or the adjoining areas since this may cause the color tone to vary. Do not touch the display with bare hands. This will stain the display area and degraded insulation between terminals (some cosmetics are determined to the polarizer).

(4) The polarizer covering the display surface of the LCD module is soft and easily scratched. Handle this polarizer carefully. Do not touch, push or rub the exposed polarizers with anything harder than an HB pencil lead (glass, tweezers, etc.). Do not put or attach anything on the display area to avoid leaving marks on. Condensation on the surface and contact with terminals due to cold will damage, stain or dirty the polarizer. After products are tested at low temperature they must be warmed up in a container before coming is contacting with room temperature air.

(5) If the display surface becomes contaminated, breathe on the surface and gently wipe it with a soft dry cloth. If it is heavily contaminated, moisten cloth with one of the following solvents

- Isopropyl alcohol
- Ethyl alcohol

Do not scrub hard to avoid damaging the display surface.

(6) Solvents other than those above-mentioned may damage the polarizer. Especially, do not use the following.

- Water
- Ketone
- Aromatic solvents

Wipe off saliva or water drops immediately, contact with water over a long period of time may cause deformation or color fading. Avoid contacting oil and fats.

(7) Exercise care to minimize corrosion of the electrode. Corrosion of the electrodes is accelerated by water droplets, moisture condensation or a current flow in a high-humidity environment.

(8) Install the LCD Module by using the mounting holes. When mounting the LCD module make sure it is free of twisting, warping and distortion. In particular, do not forcibly pull or bend the I/O cable or the backlight cable.

(9) Do not attempt to disassemble or process the LCD module.

(10) NC terminal should be open. Do not connect anything.

(11) If the logic circuit power is off, do not apply the input signals.

(12) Electro-Static Discharge Control, Since this module uses a CMOS LSI, the same careful attention should be paid to electrostatic discharge as for an ordinary CMOS IC. To prevent destruction of the elements by static electricity, be careful to maintain an optimum work environment.

- Before remove LCM from its packing case or incorporating it into a set, be sure the module and your body have the same electric potential. Be sure to ground the body when handling the LCD modules.

- Tools required for assembling, such as soldering irons, must be properly grounded. make certain the AC power source for the soldering iron does not leak. When using an electric screwdriver to attach LCM, the screwdriver should be of ground potentiality to minimize as much as possible any transmission of electromagnetic waves produced sparks coming from the commutator of the motor.

- To reduce the amount of static electricity generated, do not conduct assembling and other work under dry conditions. To reduce the generation of static electricity be careful that the air in the work is not too dried. A relative humidity of 50%-60% is recommended. As far as possible make the electric potential of your work clothes and that of the work bench the ground potential

- The LCD module is coated with a film to protect the display surface. Exercise care when peeling off this protective film since static electricity may be generated

(13) Since LCM has been assembled and adjusted with a high degree of precision, avoid applying excessive shocks to the module or making any alterations or modifications to it.

- Do not alter, modify or change the shape of the tab on the metal frame.
- Do not make extra holes on the printed circuit board, modify its shape or change the positions of components to be attached.
- Do not damage or modify the pattern writing on the printed circuit board.
- Absolutely do not modify the zebra rubber strip (conductive rubber) or heat seal connector.
- Except for soldering the interface, do not make any alterations or modifications with a soldering iron.
- Do not drop, bend or twist LCM.

Storage Precautions

When storing the LCD modules, the following precaution is necessary.

- (1) Store them in a sealed polyethylene bag. If properly sealed, there is no need for the dessicant.
- (2) Store them in a dark place. Do not expose to sunlight or fluorescent light, keep the temperature between 0°C and 35°C.
- (3) The polarizer surface should not come in contact with any other objects. (We advise you to store them in the container in which they were shipped).

Others

Liquid crystals solidify under low temperature (below the storage temperature range) leading to defective orientation or the generation of air bubbles (black or white). Air bubbles may also be generated if the module is subject to a low temperature.

If the LCD modules have been operating for a long time showing the same display patterns, the display patterns may remain on the screen as ghost images and a slight contrast irregularity may also appear. A normal operating status can be regained by suspending use for some time. It should be noted that this phenomenon does not adversely affect performance reliability.

To minimize the performance degradation of the LCD modules resulting from destruction caused by static electricity etc., exercise care to avoid holding the following sections when handling the modules.

- Exposed area of the printed circuit board.
- Terminal electrode sections.

Handling precaution for LCM

LCM is easy to be damaged.
Please note below and be careful for handling!

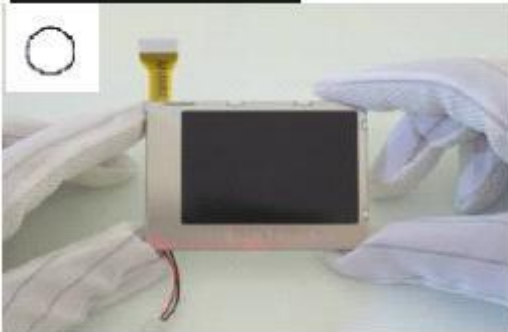
Correct handling:

As above picture, please handle with anti-static gloves around LCM edges.

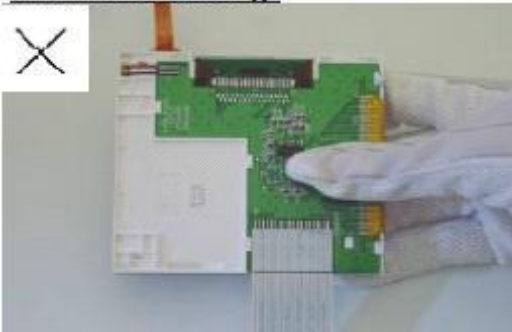
Incorrect handling:

Please don't touch IC directly.

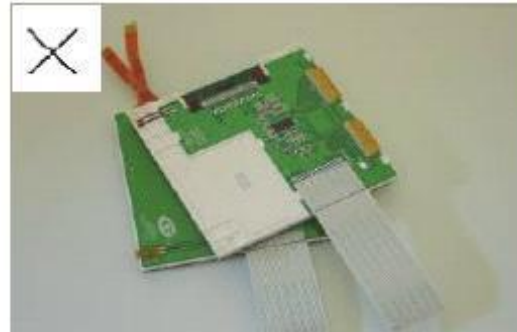

Please don't stack LCM.

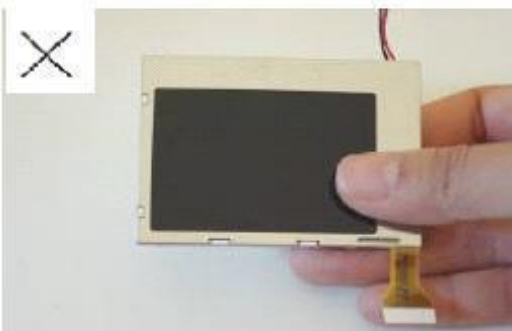

Please don't hold the surface of panel.

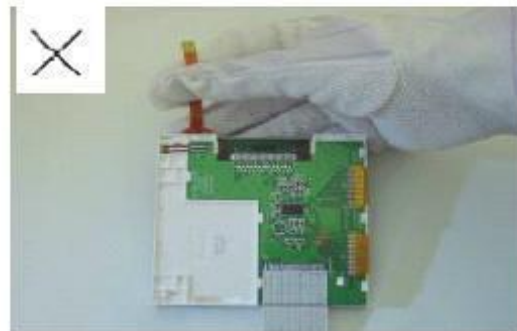

Please don't stretch interface of output, such as FPC cable.

Handling precaution for LCD

LCD is easy to be damaged.
Please note below and be careful for handling!

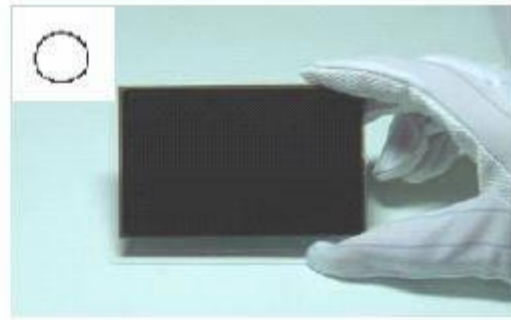
Correct handling:

As above photo, please handle with anti-static gloves around LCD edges.

Incorrect handling:

Please don't stack the LCDS.

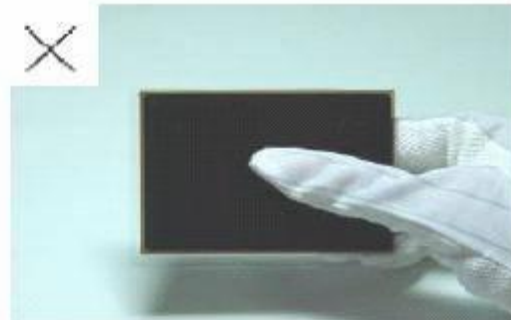

Please don't hold the surface of LCD.

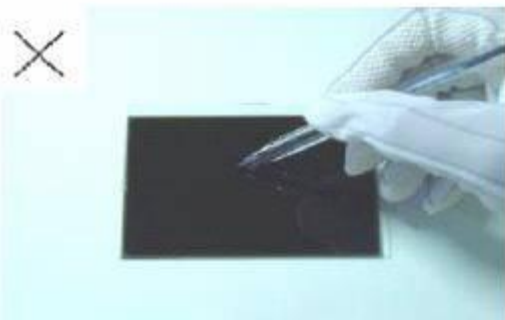

Please don't operate with sharp stick such as pens.

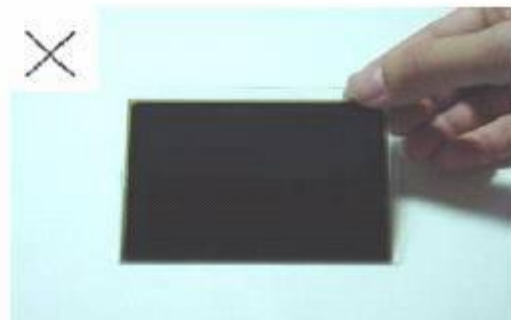

Please don't touch ITO glass without anti-static gloves.

Storage Precautions

When storing the LCD modules, the following precaution is necessary.

- (1) Store them in a sealed polyethylene bag. If properly sealed, there is no need for the dessicant.
- (2) Store them in a dark place. Do not expose to sunlight or fluorescent light, keep the temperature between 0°C and 35°C, and keep the relative humidity between 40%RH and 60%RH.
- (3) The polarizer surface should not come in contact with any other objects. (We advise you to store them in the anti-static electricity container in which they were shipped.

Others

Liquid crystals solidify under low temperature (below the storage temperature range) leading to defective orientation or the generation of air bubbles (black or white). Air bubbles may also be generated if the module is subject to a low temperature.

If the LCD modules have been operating for a long time showing the same display patterns, the display patterns may remain on the screen as ghost images and a slight contrast irregularity may also appear. A normal operating status can be regained by suspending use for some time. It should be noted that this phenomenon does not adversely affect performance reliability.

To minimize the performance degradation of the LCD modules resulting from destruction caused by static electricity etc., exercise care to avoid holding the following sections when handling the modules.

- Exposed area of the printed circuit board.
- Terminal electrode sections.

USING LCD MODULES

Installing LCD Modules

The hole in the printed circuit board is used to fix LCM as shown in the picture below. Attend to the following items when installing the LCM.

- (1) Cover the surface with a transparent protective plate to protect the polarizer and LC cell.

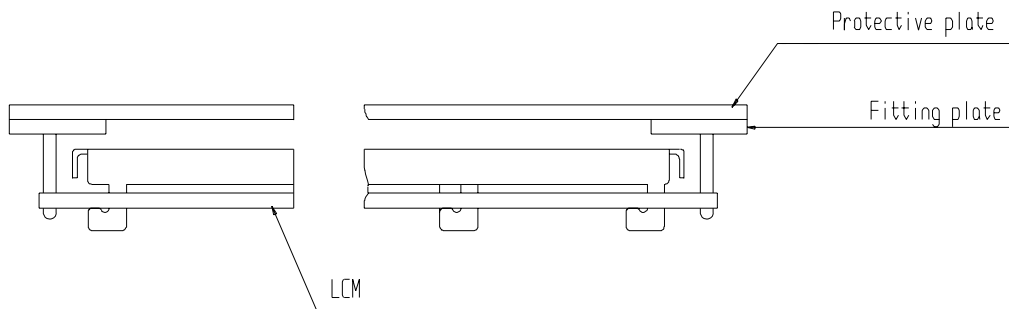

- (2) When assembling the LCM into other equipment, the spacer to the bit between the LCM and the fitting plate should have enough height to avoid causing stress to the module surface, refer to the individual specifications for measurements. The measurement tolerance should be $\pm 0.1\text{mm}$.

Precaution for assemble the module with BTB connector:

Please note the position of the male and female connector position, don't assemble or assemble like the method which the following picture shows

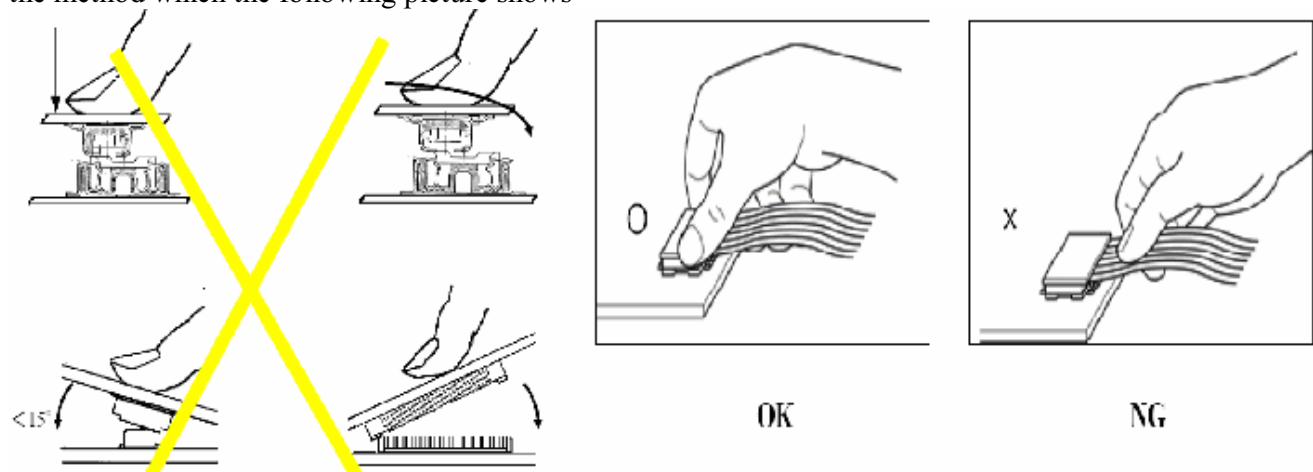

Precaution for soldering to the LCM

| | Hand soldering | Machine drag soldering | Machine press soldering |
|-----------------|-------------------------------|------------------------------------|----------------------------------------------------|
| No ROHS product | 290°C ~350°C. Time : 3-5S. | 330°C ~350°C. Speed : 4-8 mm/s. | 300°C ~330°C. Time : 3-6S. Press: 0.8~1.2Mpa |
| ROHS product | 340°C ~370°C. Time : 3-5S. | 350°C ~370°C. Time : 4-8 mm/s. | 330°C ~360°C. Time : 3-6S. Press: 0.8~1.2Mpa |

(1) If soldering flux is used, be sure to remove any remaining flux after finishing to soldering operation. (This does not apply in the case of a non-halogen type of flux.) It is recommended that you protect the LCD surface with a cover during soldering to prevent any damage due to flux spatters.

(2) When soldering the electroluminescent panel and PC board, the panel and board should not be detached more than three times. This maximum number is determined by the temperature and time conditions mentioned above, though there may be some variance depending on the temperature of the soldering iron.

(3) When remove the electroluminescent panel from the PC board, be sure the solder has completely melted, the soldered pad on the PC board could be damaged.

Precautions for Operation

(1) Viewing angle varies with the change of liquid crystal driving voltage (VLCD). Adjust VLCD to show the best contrast.

(2) It is an indispensable condition to drive LCD's within the specified voltage limit since the higher voltage then the limit cause the shorter LCD life. An electrochemical reaction due to direct current causes LCD's undesirable deterioration, so that the use of direct current drive should be avoided.

(3) Response time will be extremely delayed at lower temperature than the operating temperature range and on the other hand at higher temperature LCD's show dark color in them. However those phenomena do not mean malfunction or out of order with LCD's, Which will come back in the specified operating temperature.

(4) If the display area is pushed hard during operation, the display will become abnormal. However, it will return to normal if it is turned off and then back on.

(5) A slight dew depositing on terminals is a cause for electro-chemical reaction resulting in terminal open circuit. Usage under the maximum operating temperature,50%RH or less is required.

(6) Input each signal after the positive/negative voltage becomes stable.

(7) Please keep the temperature within specified range for use and storage. Polarization degradation, bubble generation or polarizer peel-off may occur with high temperature and high humidity.

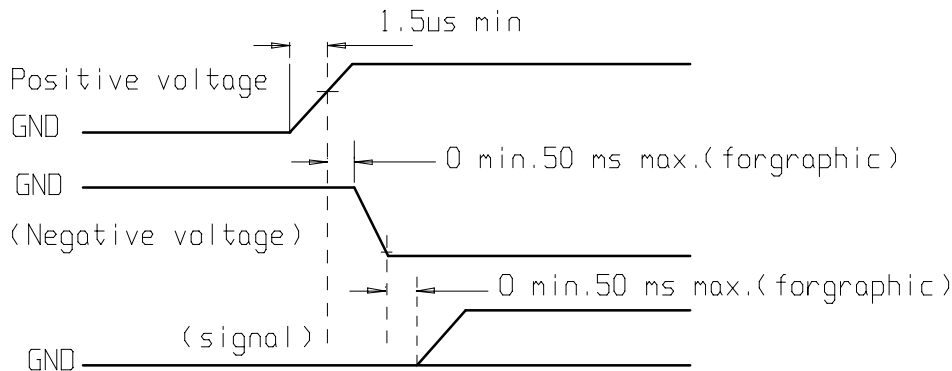

Safety

(1) It is recommended to crush damaged or unnecessary LCDs into pieces and wash them off with solvents such as acetone and ethanol, which should later be burned.

(2) If any liquid leaks out of a damaged glass cell and comes in contact with the hands, wash off thoroughly with soap and water.

Limited Warranty

Unless agreed between Multi-Inno and customer, Multi-Inno will replace or repair any of its LCD modules which are found to be functionally defective when inspected in accordance with Multi-Inno LCD acceptance standards (copies available upon request) for a period of one year from date of production. Cosmetic/visual defects must be returned to Multi-Inno within 90 days of shipment. Confirmation of such date shall be based on data code on product. The warranty liability of Multi-Inno limited to repair and/or replacement on the terms set forth above. Multi-Inno will not be responsible for any subsequent or consequential events.

Return LCM under warranty

No warranty can be granted if the precautions stated above have been disregarded. The typical examples of violations are :

- Broken LCD glass.
- PCB eyelet is damaged or modified.
- PCB conductors damaged.
- Circuit modified in any way, including addition of components.
- PCB tampered with by grinding, engraving or painting varnish.
- Soldering to or modifying the bezel in any manner.

Module repairs will be invoiced to the customer upon mutual agreement. Modules must be returned with sufficient description of the failures or defects. Any connectors or cable installed by the customer must be removed completely without damaging the PCB eyelet, conductors and terminals.

■ PRIOR CONSULT MATTER

- 1.①For Multi-Inno standard products, we keep the right to change material, process ... for improving the product property without notice on our customer.
②For OEM products, if any change needed which may affect the product property, we will consult with our customer in advance.
2. If you have special requirement about reliability condition, please let us know before you start the test on our samples.