



**MULTI-INNO TECHNOLOGY CO., LTD.**

[www.multi-inno.com](http://www.multi-inno.com)

## LCD MODULE SPECIFICATION

**Model : MI0160A1T-2**

This module uses ROHS material

### For Customer's Acceptance:

Customer	
Approved	
Comment	

This specification may change without prior notice in order to improve performance or quality. Please contact Multi-Inno for updated specification and product status before design for this product or release of this order.

Revision	1.0
Engineering	
Date	2013-07-30
Our Reference	



## CONTENTS

- GENERAL INFORMATION
- EXTERNAL DIMENSIONS
- ABSOLUTE MAXIMUM RATINGS
- ELECTRICAL CHARACTERISTICS
- BACKLIGHT CHARACTERISTICS
- ELECTRO-OPTICAL CHARACTERISTICS
- INTERFACE DESCRIPTION
- REFERENCE APPLICATION CIRCUIT
- RELIABILITY TEST CONDITIONS
- INSPECTION CRITERION
- PRECAUTIONS FOR USING LCD MODULES
- PACKING SPECIFICATION
- PRIOR CONSULT MATTER

**■ GENERAL INFORMATION**

Item of general information	Contents	Unit
LCD type	TFT/Transflective/Normally white	/
Recommended viewing direction	5~7	O' Clock
Module area (W × H×T)	34.80×38.70×2.35	mm <sup>3</sup>
Viewing area (W×H)	29.40×29.40	mm <sup>2</sup>
Active area (W×H)	28.80×28.80	mm <sup>2</sup>
Number of Dots	240RGB×240	/
Pixel pitch (W × H)	0.12×0.12	mm <sup>2</sup>
Driver IC	ST7789S	/
CTP Driver IC	FT6206	/
Interface Type	SPI	/
Input voltage	2.8	V
Module Power consumption	TBD	mw
Backlight Type	3 LEDs	/
With/Without TSP	With CTP	/
Weight	TBD	g

Note 1: RoHS compliant;

Note 2: LCM weight tolerance: ± 5%.

## EXTERNAL DIMENSIONS

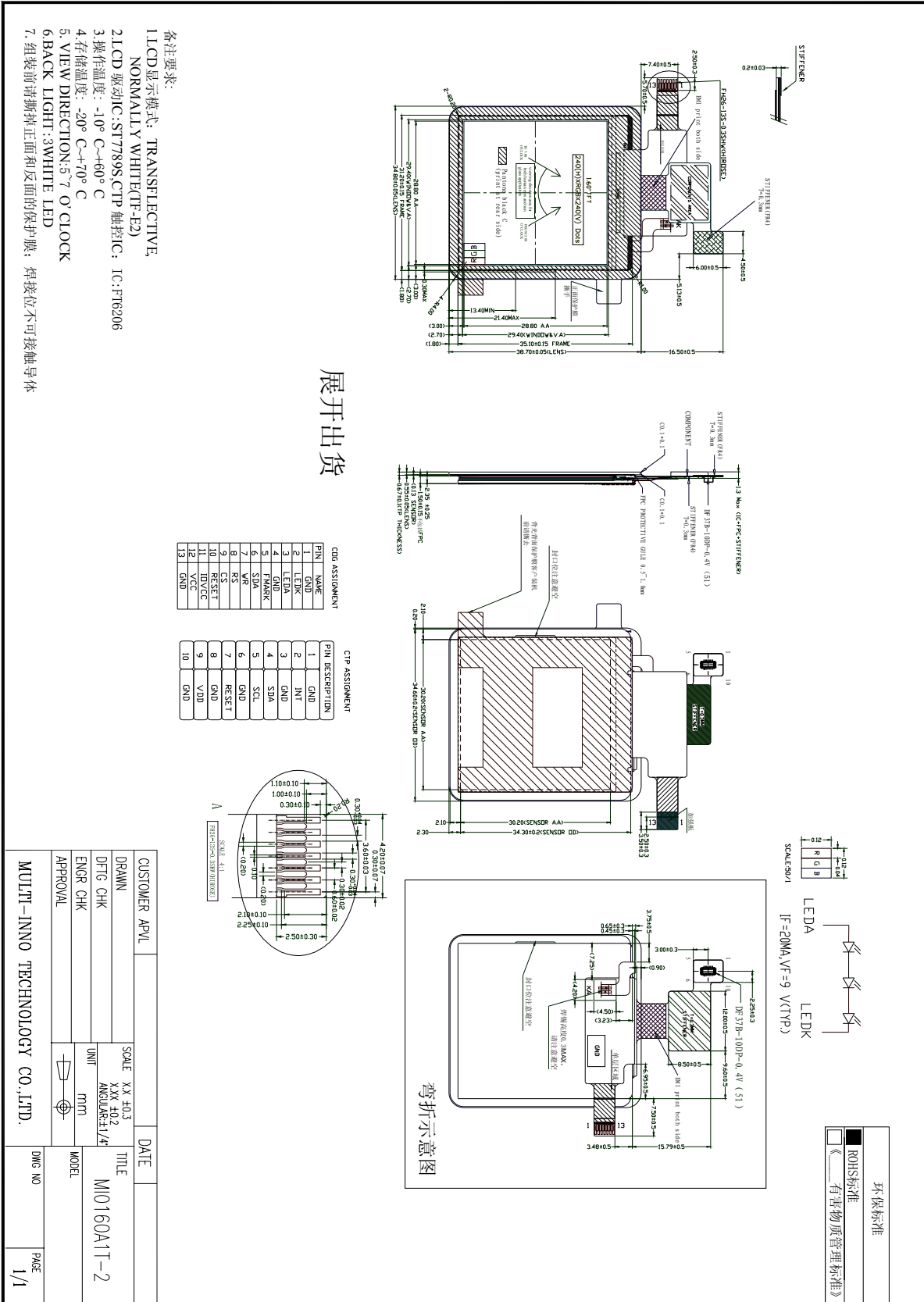

## ■ ABSOLUTE MAXIMUM RATINGS

Parameter of absolute maximum ratings	Symbol	Min	Max	Unit
Supply voltage for logic	VCC/IOVCC	-0.3	4.6	V
Supply voltage for CTP	VDD	-0.3	3.6	V
Input voltage	VIN	0.5	IOVCC+0.5	V
Operating temperature	Top	-10	60	°C
Storage temperature	TST	-20	70	°C
Humidity	RH	-	90%(Max60 °C)	RH

Note: Absolute maximum ratings means the product can withstand short-term, NOT more than 120 hours. If the product is a long time to withstand these conditions, the life time would be shorter.

## ■ ELECTRICAL CHARACTERISTICS

### DC CHARACTERISTICS

Parameter of DC characteristics	Symbol	Min	Typ	Max	Unit
Supply voltage for logic	VCC	2.4	2.8	3.3	V
Supply voltage for CTP	VDD	2.8	2.8	3.3	V
I/O power supply	IOVCC	1.65	1.8	3.3	V
Input Current	I <sub>dd</sub>	-	TBD	TBD	mA
Input voltage 'H' level	V <sub>IH</sub>	0.7IOVCC	-	IOVCC	V
Input voltage 'L' level	V <sub>IL</sub>	GND	-	0.3IOVCC	V
Output voltage 'H' level	V <sub>OH</sub>	0.8IOVCC	-	IOVCC	V
Output voltage 'L' level	V <sub>OL</sub>	GND	-	0.2IOVCC	V

## ■ BACKLIGHT CHARACTERISTICS

Item of backlight characteristics	Symbol	Min.	Typ.	Max.	Unit	Condition
Forward voltage	Vf	7.8	9.0	10	V	If=20mA;Ta=25°C
Number of LED	-	-	3	-	Piece	-
Connection mode	S	-	Serial	-	-	-

Using condition: constant current driving method If=20mA(+/-10%).

## ■ ELECTRO-OPTICAL CHARACTERISTICS

Item of electro-optical characteristics	Symbol	Condition	Min	Typ	Max	Unit	Remark	Note
Response time	Tr+ Tf	$\theta=0^\circ$ $\varnothing=0^\circ$ Ta=25°C	-	TBD	TBD	ms	FIG 1.	4
Contrast ratio	Cr		TBD	TBD	-	---	FIG 2.	1
Luminance uniformity	$\delta$ WHITE		TBD	TBD	-	%	FIG 2.	3
Surface Luminance	Lv		TBD	TBD	-	cd/m <sup>2</sup>	FIG 2.	2
Viewing angle range	$\theta$	$\varnothing = 90^\circ$	TBD	TBD	-	deg	FIG 3.	6
		$\varnothing = 270^\circ$	TBD	TBD	-	deg	FIG 3	
		$\varnothing = 0^\circ$	TBD	TBD	-	deg	FIG 3	
		$\varnothing = 180^\circ$	TBD	TBD	-	deg	FIG 3	
NTSC ratio	-	-	-	TBD	-	%	-	-
CIE (x, y) chromaticity CIE	Red x	$\theta=0^\circ$ $\varnothing=0^\circ$ Ta=25°C	TBD	TBD	TBD	-	FIG 2.	5
	Red y		TBD	TBD	TBD	-		
	Green x		TBD	TBD	TBD	-		
	Green y		TBD	TBD	TBD	-		
	Blue x		TBD	TBD	TBD	-		
	Blue y		TBD	TBD	TBD	-		
	White x		TBD	TBD	TBD	-		
	White y		TBD	TBD	TBD	-		

Note1. Contrast Ratio(CR) is defined mathematically by the following formula. For more information see FIG 2.:

$$\text{Contrast Ratio(CR)} = \frac{\text{Average Surface Luminance with all white pixels (P1, P2, \dots)}}{\text{Average Surface Luminance with all black pixels (P1, P2, \dots)}}$$

Note2. Surface luminance is the LCD surface luminance with all white pixels. For more information see FIG 2.

$$L_v = \text{Average Surface Luminance with all white pixels (P1, P2, \dots)}$$

Note3. The uniformity in surface luminance ( $\delta$  WHITE) is determined by measuring luminance at each test position, and then dividing the maximum luminance of all white pixels by minimum luminance of all white pixels. For more information see FIG 2.

$$\delta \text{ WHITE} = \frac{\text{Minimum Surface Luminance with all white pixels (P1, P2, \dots)}}{\text{Maximum Surface Luminance with all white pixels (P1, P2, \dots)}}$$

Note4. Response time is the time required for the display to transition from White to black(Rise Time, Tr) and from black to white(Decay Time, Tf). For additional information see FIG 1..

Note5. CIE(x, y) chromaticity is the Center point value. For more information see FIG 2.

Note6. Viewing angle is the angle at which the contrast ratio is greater than a specific value. For TFT module, the specific value of contrast ratio is 10; For monochrome and color stn module, the specific value of contrast ratio is 2.The angles are determined for the horizontal or x axis and the vertical or y axis with respect to the z axis which is normal to the LCD surface. For more information see FIG 3.

Note7. For Viewing angle and response time testing, the testing data is base on Autronic-Melchers's ConoScope. Series Instruments. For contrast ratio, Surface Luminance, Luminance uniformity and CIE, the testing data is base on CS-2000 photo detector.

Note8. For TN type TFT transmissive module, Gray scale reverse occurs in the direction of panel viewing angle

**FIG.1. The definition of Response Time**

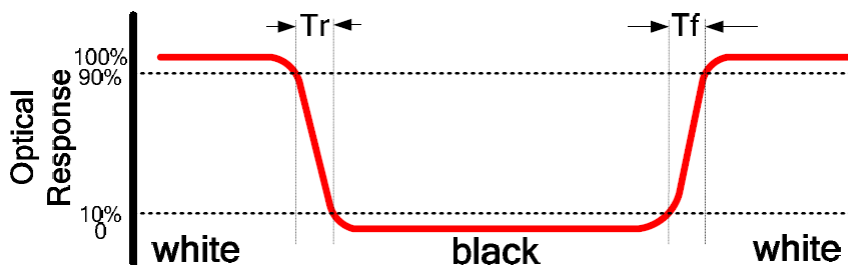

**FIG.2. Measuring method for Contrast ratio, surface luminance, Luminance uniformity,CIE (x, y) chromaticity**

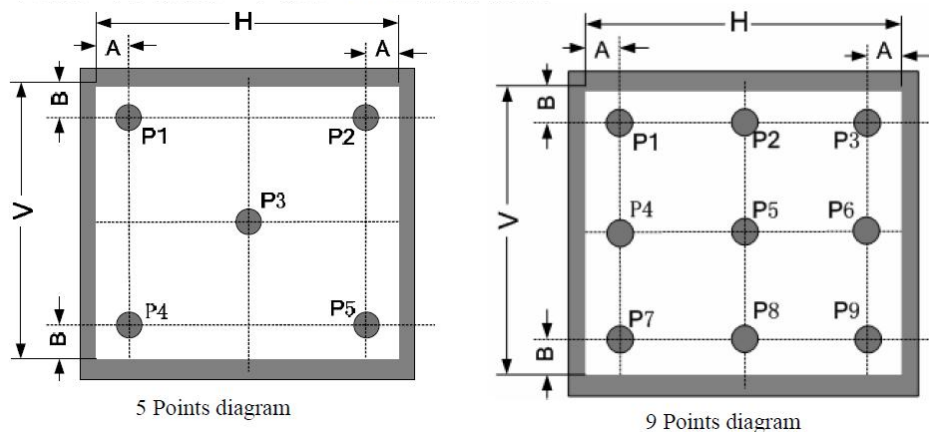



Fig2 Note1 For TFT Module Test point:9 points( as 9 Points diagram )

A :  $H/6$  (if AA size $<4.0$ inch);  $H/10$  (if AA size $\geq 4.0$ inch)

B :  $V/6$  (if AA size $<4.0$ inch);  $V/10$  (if AA size $\geq 4.0$ inch)

H,V : Active Area(AA) size

Measurement instrument: CS-2000; Light spot size  $\varnothing=5$ mm, 350mm distance from the LCD surface to detector lens.

Fig2 Note2 For non-TFT Module and Dot-Matrix type Module

2.1 If the minimum side size is bigger than 20 mm,the testing method is the same as TFT module.

2.2 If the minimum side size is less than 20 mm, then testing 5 point datas (as 5 Points diagram), Both A and B are 5 mm.

2.3 Measurement instrument: CS-2000 is priority selected to measure.

Light spot size  $\varnothing=5$ mm, 350mm distance from the LCD surface to detector lens.

2.4 Measurement instrument : ConoScope will be selected to measure If CS-2000 cannot meet the measurement requirement.

Light spot size  $\varnothing=0.2-2.0$ mm. About 2-3mm distance from the LCD surface to detector lens, but suggest to confirm the best distance on focusing the picture to be clearest when actually measuring.

Fig2 Note3 For non-TFT Module and non-Dot-Matrix type Module

The test point is defined by the fact size and shape of module,but the center point and four edges should be selected.

3.1 Measurement instrument: CS-2000 is priority selected to measure..

Light spot size  $\varnothing=5$ mm, 350mm distance from the LCD surface to detector lens.

3.2 Measurement instrument : ConoScope will be selected to measure If CS-2000 cannot meet the measurement requirement.

Light spot size  $\varnothing=0.2-2.0$ mm. About 2-3mm distance from the LCD surface to detector lens, but suggest to confirm the best distance on focusing the picture to be clearest when actually measuring.

**FIG.3. The definition of viewing angle**

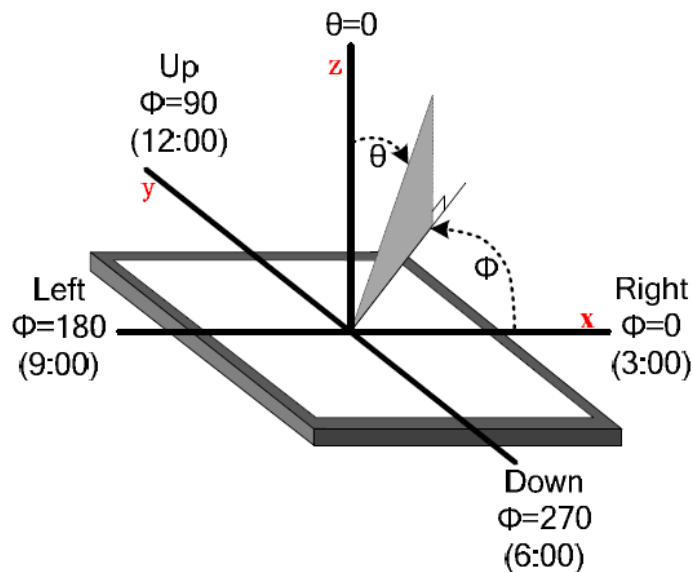

## ■ INTERFACE DESCRIPTION

Interface NO.	Symbol	I/O or connect to	Description	When not in use
1	GND	Power supply	Power Ground	-
2	LEDK	Power supply	LED Cathode	-
3	LEDA	Power supply	LED Anode	-
4	GND	Power supply	Power Ground	-
5	FMARK	O Host processor	Tearing effect signal is used to synchronize MCU to frame memory writing.	OPEN
6	SDA	I/O Host processor	SPI interface input/output pin. The data is latched on the rising edge of the SCL signal.	IOVCC /GND
7	WR	I Host processor	Second Data lane in 2 data lane serial interface	IOVCC /GND
8	RS	I Host processor	This pin is used to be serial interface clock.RS='1': display data or parameter.RS='0': command data.	IOVCC /GND
9	CS	I Host processor	Chip selection pin Low enable. High disable.	-
10	RESET	I Host processor	This signal will reset the device and it must be applied to properly initialize the chip. Signal is active low	-
11	IOVCC	Power supply	Power Supply for I/O system.IOVCC=1.65V ~ 3.3V	-
12	VCC	Power supply	Power Supply for Analog, Digital System and Booster Circuit.VCI=2.4V ~ 3.3V	-
13	GND	Power supply	Power Ground	-

## CTP INTERFACE

Interface NO.	Symbol	Level	Description	when not in use
1	GND	Power supply	Power Ground	-
2	INT	I/O Host processor	External interrupt to the host	-
3	GND	Power supply	Power Ground	-
4	SDA	I/O Host processor	I2C data input and output	-
5	SCL	I/O Host processor	I2C clock input	-
6	GND	Power supply	Power Ground	-
7	RESET	I Host processor	External Reset, Low is active	-
8	GND	Power supply	Power Ground	-
9	VDD	Power supply	Analog power supply,VDD=2.8V~3.3V	-
10	GND	Power supply	Power Ground	-

## ■ REFERENCE APPLICATION CIRCUIT

Please consult our technical department for detail information.

## ■ RELIABILITY TEST CONDITIONS

No.	Test Item	Test Condition	Inspection after test
1	High Temperature Storage	$70 \pm 2^{\circ}\text{C}/120$ hours	Inspection after 2~4hours storage at room temperature, the sample shall be free from defects: 1.Air bubble in the LCD; 2.Sealleak; 3.Non-display; 4.missing segments; 5.Glass crack; 6, the surface shall be free from damage. 7.Linearity must be no more than 3.0% by the linearity tester. 8. The <b>electrical characteristics</b> requirements shall be satisfied.
2	Low Temperature Storage	$-20 \pm 2^{\circ}\text{C}/120$ hours	
3	High Temperature Operating	$60 \pm 2^{\circ}\text{C}/120$ hours	
4	Low Temperature Operating	$-10 \pm 2^{\circ}\text{C}/120$ hours	
5	Temperature Cycle storage	$-10 \pm 2^{\circ}\text{C} \sim 25 \sim 60 \pm 2^{\circ}\text{C} \times 10$ cycles (30min.) (5min.) (30min.)	
6	Damp proof Test operating	$50^{\circ}\text{C} \pm 5^{\circ}\text{C} \times 90\% \text{RH}/120$ hours	
7	Vibration Test	Frequency: 10Hz~55Hz~10Hz Amplitude: 1.5mm, X, Y, Z direction for total 3hours (Packing condition)	
8	Dropping test	Drop to the ground from 1m height, one time, every side of carton. (Packing condition)	
9	ESD test	Voltage: $\pm 8\text{KV}$ R: 330 $\Omega$ C: 150pF Air discharge, 10time	

Remark:

- 1.The test samples should be applied to only one test item.
- 2.Sample size for each test item is 5~10pcs.
- 3.For Damp Proof Test, Pure water(Resistance > 10M $\Omega$ ) should be used.
- 4.In case of malfunction defect caused by ESD damage, if it would be recovered to normal state after resetting, it would be judged as a good part.
- 5.EL evaluation should be excepted from reliability test with humidity and temperature: Some defects such as black spot/blemish can happen by natural chemical reaction with humidity and Fluorescence EL has.
- 6.Failure Judgment Criterion: Basic Specification, Electrical Characteristic, Mechanical Characteristic, Optical Characteristic.

## ■ INSPECTION CRITERION

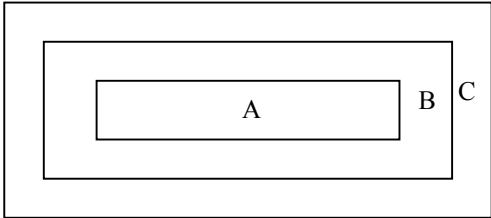
 OUTGOING QUALITY STANDARD	PAGE 1 OF 10 Edition: D
TITLE:FUNCTIONAL TEST & INSPECTION CRITERIA	within 4.5" I-touch module Product
<p>This specification is made to be used as the standard acceptance/rejection criteria for I-touch module Product (within 4.5") .</p> <p><b>1 Sample plan</b></p> <p>Sampling plan according to GB/T2828.1-2003/ISO 2859-1 : 1999 and ANSI/ASQC Z1.4-1993, normal level 2 and based on:</p> <p>Major defect: AQL 0.65                  Minor defect: AQL 1.5</p> <p><b>2. Inspection condition</b></p> <p>Viewing distance for cosmetic inspection is about 30cm with bare eyes, and under an environment of 20~40W light intensity, all directions for inspecting the sample should be within 45° against perpendicular line.</p> <p><b>3. Definition of inspection zone in LCD</b></p> <div data-bbox="440 1094 927 1310" data-label="Diagram">  </div> <p>Zone A: character/Digit area                  Zone B: viewing area except Zone A (Zone A + Zone B=minimum Viewing area)                  Zone C: Outside viewing area (invisible area after assembly in customer's product)</p> <p>Fig.1 Inspection zones in an LCD.</p> <p>Note: As a general rule, visual defects in Zone C are permissible, when it is no trouble for quality and assembly of customer's product.</p>	

	<b>OUTGOING QUALITY STANDARD</b>	PAGE 2 OF 10 Edition: D
TITLE:FUNCTIONAL TEST & INSPECTION CRITERIA		within 4.5" I-touch module Product

**4. Definition of inspection zone in CTP**

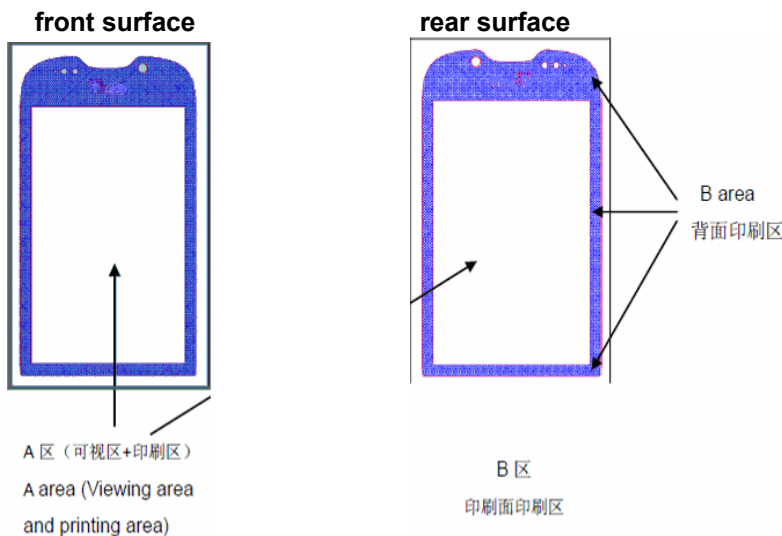

**5. Inspection standards**

**5.1 Major Defect**

Item No	Items to be inspected	Inspection Standard	Classification of defects
5.1.1	All functional defects	1) No display 2) Display abnormally 3) Missing vertical, horizontal segment 4) Short circuit 5) Back-light no lighting, flickering and abnormal lighting. 6) No reaction when touching it	Major
5.1.2	Missing	Missing component	
5.1.3	Outline dimension	Overall outline dimension beyond the drawing is not allowed.	

		OUTGOING QUALITY STANDARD	PAGE 3 OF 10 Edition: D																								
TITLE:FUNCTIONAL TEST & INSPECTION CRITERIA			within 4.5" I-touch module Product																								
<b>5.2 Cosmetic Defect</b>																											
Item No	Items to be inspected	Inspection Standard		Classification of defects																							
For dark/white spot, size $\Phi$ is defined as $\Phi = \frac{(x+y)}{2}$																											
5.2.1	LCD Clear Spots  Black and white Spot defect Pinhole, Foreign Particle, Dirt under polarizer	<table border="1" style="width: 100%; border-collapse: collapse;"> <thead> <tr> <th rowspan="2" style="text-align: center;">Zone Size(mm)</th> <th colspan="3" style="text-align: center;">Acceptable Qty</th> </tr> <tr> <th style="text-align: center;">A</th> <th style="text-align: center;">B</th> <th style="text-align: center;">C</th> </tr> </thead> <tbody> <tr> <td style="text-align: center;"><math>\Phi \leq 0.1</math></td> <td colspan="3" style="text-align: center;">Ignore</td> </tr> <tr> <td style="text-align: center;"><math>0.10 &lt; \Phi \leq 0.15</math></td> <td colspan="3" style="text-align: center;">2</td> </tr> <tr> <td style="text-align: center;"><math>0.15 &lt; \Phi \leq 0.2</math></td> <td colspan="3" style="text-align: center;">1</td> </tr> <tr> <td style="text-align: center;"><math>0.2 &lt; \Phi</math></td> <td colspan="3" style="text-align: center;">0</td> </tr> </tbody> </table>		Zone Size(mm)	Acceptable Qty			A	B	C	$\Phi \leq 0.1$	Ignore			$0.10 < \Phi \leq 0.15$	2			$0.15 < \Phi \leq 0.2$	1			$0.2 < \Phi$	0			Minor
	Zone Size(mm)	Acceptable Qty																									
A		B	C																								
$\Phi \leq 0.1$	Ignore																										
$0.10 < \Phi \leq 0.15$	2																										
$0.15 < \Phi \leq 0.2$	1																										
$0.2 < \Phi$	0																										
CTP Clear Spots  Black and white Spot Stain Inclusion saw edge pin holes	<table border="1" style="width: 100%; border-collapse: collapse;"> <thead> <tr> <th rowspan="2" style="text-align: center;">Zone Size(mm)</th> <th colspan="1" style="text-align: center;">Acceptable Qty</th> </tr> <tr> <th style="text-align: center;">Including view area/ BM area of front surface</th> </tr> </thead> <tbody> <tr> <td style="text-align: center;"><math>\Phi \leq 0.10</math></td> <td style="text-align: center;">Ignore</td> </tr> <tr> <td style="text-align: center;"><math>0.10 &lt; \Phi \leq 0.15</math></td> <td style="text-align: center;">6</td> </tr> <tr> <td style="text-align: center;"><math>0.15 &lt; \Phi \leq 0.25</math></td> <td style="text-align: center;">4</td> </tr> <tr> <td style="text-align: center;"><math>0.25 &lt; \Phi</math></td> <td style="text-align: center;">0</td> </tr> </tbody> </table>		Zone Size(mm)	Acceptable Qty	Including view area/ BM area of front surface	$\Phi \leq 0.10$	Ignore	$0.10 < \Phi \leq 0.15$	6	$0.15 < \Phi \leq 0.25$	4	$0.25 < \Phi$	0														
Zone Size(mm)	Acceptable Qty																										
	Including view area/ BM area of front surface																										
$\Phi \leq 0.10$	Ignore																										
$0.10 < \Phi \leq 0.15$	6																										
$0.15 < \Phi \leq 0.25$	4																										
$0.25 < \Phi$	0																										

OUTGOING QUALITY STANDARD		PAGE 4 OF 10 Edition: D																																			
TITLE:FUNCTIONAL TEST & INSPECTION CRITERIA		within 4.5" I-touch module Product																																			
Item No	Items to be inspected	Inspection Standard			Classification of defects																																
5.2.2	CTP Dent Spot fish eye	<table border="1"> <thead> <tr> <th rowspan="2">Zone Size(mm)</th> <th colspan="2">Acceptable Qty</th> </tr> <tr> <th colspan="2">Including view area/ BM area of front surface</th> </tr> </thead> <tbody> <tr> <td><math>\Phi \leq 0.10</math></td> <td colspan="2">Ignore</td> </tr> <tr> <td><math>0.10 &lt; \Phi \leq 0.20</math></td> <td colspan="2">2</td> </tr> <tr> <td><math>0.20 &lt; \Phi</math></td> <td colspan="2">0</td> </tr> </tbody> </table>	Zone Size(mm)	Acceptable Qty		Including view area/ BM area of front surface		$\Phi \leq 0.10$	Ignore		$0.10 < \Phi \leq 0.20$	2		$0.20 < \Phi$	0		Minor																				
Zone Size(mm)	Acceptable Qty																																				
	Including view area/ BM area of front surface																																				
$\Phi \leq 0.10$	Ignore																																				
$0.10 < \Phi \leq 0.20$	2																																				
$0.20 < \Phi$	0																																				
5.2.3	LCD Dim Spots  Circle shaped and dim edged defects	<table border="1"> <thead> <tr> <th rowspan="2">Zone Size(mm)</th> <th colspan="3">Acceptable Qty</th> </tr> <tr> <th>A</th> <th>B</th> <th>C</th> </tr> </thead> <tbody> <tr> <td><math>\Phi \leq 0.2</math></td> <td colspan="3">Ignore</td> </tr> <tr> <td><math>0.20 &lt; \Phi \leq 0.40</math></td> <td colspan="3">3</td> </tr> <tr> <td><math>0.40 &lt; \Phi \leq 0.60</math></td> <td colspan="3">2</td> </tr> <tr> <td><math>0.60 &lt; \Phi \leq 0.8</math></td> <td colspan="3">1</td> </tr> <tr> <td><math>0.8 &lt; \Phi</math></td> <td colspan="3">0</td> </tr> </tbody> </table>	Zone Size(mm)	Acceptable Qty			A	B	C	$\Phi \leq 0.2$	Ignore			$0.20 < \Phi \leq 0.40$	3			$0.40 < \Phi \leq 0.60$	2			$0.60 < \Phi \leq 0.8$	1			$0.8 < \Phi$	0			Minor							
Zone Size(mm)	Acceptable Qty																																				
	A	B	C																																		
$\Phi \leq 0.2$	Ignore																																				
$0.20 < \Phi \leq 0.40$	3																																				
$0.40 < \Phi \leq 0.60$	2																																				
$0.60 < \Phi \leq 0.8$	1																																				
$0.8 < \Phi$	0																																				
5.2.4	LCD Line defect Black line, White line, Foreign material under polarizer	<table border="1"> <thead> <tr> <th colspan="2">Size(mm)</th> <th colspan="3">Acceptable Qty</th> </tr> <tr> <th rowspan="2">L(Length)</th> <th rowspan="2">W(Width)</th> <th colspan="3">Zone</th> </tr> <tr> <th>A</th> <th>B</th> <th>C</th> </tr> </thead> <tbody> <tr> <td>Ignore</td> <td><math>W \leq 0.02</math></td> <td colspan="3">Ignore</td> </tr> <tr> <td><math>L \leq 3.0</math></td> <td><math>0.02 &lt; W \leq 0.03</math></td> <td colspan="3">2</td> </tr> <tr> <td><math>L \leq 2.0</math></td> <td><math>0.03 &lt; W \leq 0.05</math></td> <td colspan="3">1</td> </tr> <tr> <td></td> <td><math>0.05 &lt; W</math></td> <td colspan="3">Define as spot defect</td> </tr> </tbody> </table>	Size(mm)		Acceptable Qty			L(Length)	W(Width)	Zone			A	B	C	Ignore	$W \leq 0.02$	Ignore			$L \leq 3.0$	$0.02 < W \leq 0.03$	2			$L \leq 2.0$	$0.03 < W \leq 0.05$	1				$0.05 < W$	Define as spot defect			Minor	
Size(mm)		Acceptable Qty																																			
L(Length)	W(Width)	Zone																																			
		A	B	C																																	
Ignore	$W \leq 0.02$	Ignore																																			
$L \leq 3.0$	$0.02 < W \leq 0.03$	2																																			
$L \leq 2.0$	$0.03 < W \leq 0.05$	1																																			
	$0.05 < W$	Define as spot defect																																			

 OUTGOING QUALITY STANDARD		PAGE 5 OF 10 Edition: D																																			
TITLE:FUNCTIONAL TEST & INSPECTION CRITERIA		within 4.5" I-touch module Product																																			
Item No	Items to be inspected	Inspection Standard		Classification of defects																																	
5.2.4	CTP Line defect Linear/ foreign fiber	Reject: Out of below spec  <table border="1"> <thead> <tr> <th colspan="2">Size(mm)</th> <th colspan="2">Acceptable Qty</th> </tr> <tr> <th rowspan="2">L(Length)</th> <th rowspan="2">W(Width)</th> <th colspan="2">Zone</th> </tr> <tr> <th colspan="2">Including view area/ BM area of front surface</th> </tr> </thead> <tbody> <tr> <td>Ignore</td> <td><math>W \leq 0.01</math></td> <td colspan="2">Ignore</td> </tr> <tr> <td><math>L \leq 5.0</math></td> <td><math>0.01 &lt; W \leq 0.03</math></td> <td colspan="2">2</td> </tr> <tr> <td><math>L \leq 2.0</math></td> <td><math>0.03 &lt; W \leq 0.05</math></td> <td colspan="2">1</td> </tr> </tbody> </table>		Size(mm)		Acceptable Qty		L(Length)	W(Width)	Zone		Including view area/ BM area of front surface		Ignore	$W \leq 0.01$	Ignore		$L \leq 5.0$	$0.01 < W \leq 0.03$	2		$L \leq 2.0$	$0.03 < W \leq 0.05$	1		Minor											
Size(mm)		Acceptable Qty																																			
L(Length)	W(Width)	Zone																																			
		Including view area/ BM area of front surface																																			
Ignore	$W \leq 0.01$	Ignore																																			
$L \leq 5.0$	$0.01 < W \leq 0.03$	2																																			
$L \leq 2.0$	$0.03 < W \leq 0.05$	1																																			
5.2.5	Polarizer scratch	If the Polarizer scratch can be seen after mobile phone cover assembling or in the operating condition, judge by the line defect of 4.2.2.  If the Polarizer scratch can be seen only in non-operating condition or some special angle, judge by the following.  <table border="1"> <thead> <tr> <th colspan="2">Size(mm)</th> <th colspan="3">Acceptable Qty</th> </tr> <tr> <th rowspan="2">L(Length)</th> <th rowspan="2">W(Width)</th> <th colspan="3">Zone</th> </tr> <tr> <th>A</th> <th>B</th> <th>C</th> </tr> </thead> <tbody> <tr> <td>Ignore</td> <td><math>W \leq 0.03</math></td> <td colspan="3">Ignore</td> </tr> <tr> <td><math>5.0 &lt; L \leq 10.0</math></td> <td><math>0.03 &lt; W \leq 0.05</math></td> <td colspan="3">2</td> </tr> <tr> <td><math>L \leq 5.0</math></td> <td><math>0.05 &lt; W \leq 0.08</math></td> <td colspan="3">1</td> </tr> <tr> <td></td> <td><math>0.08 &lt; W</math></td> <td colspan="3">0</td> </tr> </tbody> </table>		Size(mm)		Acceptable Qty			L(Length)	W(Width)	Zone			A	B	C	Ignore	$W \leq 0.03$	Ignore			$5.0 < L \leq 10.0$	$0.03 < W \leq 0.05$	2			$L \leq 5.0$	$0.05 < W \leq 0.08$	1				$0.08 < W$	0			Minor
Size(mm)		Acceptable Qty																																			
L(Length)	W(Width)	Zone																																			
		A	B	C																																	
Ignore	$W \leq 0.03$	Ignore																																			
$5.0 < L \leq 10.0$	$0.03 < W \leq 0.05$	2																																			
$L \leq 5.0$	$0.05 < W \leq 0.08$	1																																			
	$0.08 < W$	0																																			

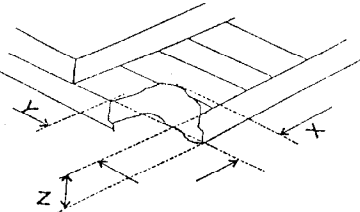

OUTGOING QUALITY STANDARD		PAGE 6 OF 10 Edition: D					
TITLE:FUNCTIONAL TEST & INSPECTION CRITERIA		within 4.5" I-touch module Product					
Item No	Items to be inspected	Inspection Standard		Classification of defects			
5.2.5	CTP scratch	Size(mm)		Acceptable Qty			
		L(Length)	W(Width)	Zone			
				Including view area/ BM area of front surface			
		Ignore	$W \leq 0.02$	Ignore			
		$L \leq 5.0$	$0.02 < W \leq 0.05$	6			
		$L \leq 5.0$	$0.05 < W \leq 0.07$	3			
Reject: Out of above spec				Minor			
5.2.6	Polarize Air bubble	Air bubbles between glass & polarizer		Minor			
		Zone			Acceptable Qty		
		Size(mm)			A	B	C
		$\Phi \leq 0.2$			Ignore		Ignore
		$0.20 < \Phi \leq 0.30$			2		
$0.30 < \Phi \leq 0.50$		1					
$0.50 < \Phi$		0					
5.2.6	CTP bubble	Zone		Acceptable Qty			
		Size(mm)		Including view area/ BM area of front surface			
		$\Phi \leq 0.10$		Ignore			
		$0.10 < \Phi \leq 0.20$		2			
		$0.20 < \Phi$		0			

OUTGOING QUALITY STANDARD		PAGE 7 OF 10 Edition: D									
TITLE:FUNCTIONAL TEST & INSPECTION CRITERIA		within 4.5" I-touch module Product									
Item No	Items to be inspected	Inspection Standard	Classification of defects								
5.2.6	OCA Air bubble	Air bubbles between CTP & LCD  <table border="1"> <thead> <tr> <th>Zone Size(mm)</th> <th>Acceptable Qty Including view area/ BM area of front surface</th> </tr> </thead> <tbody> <tr> <td><math>\Phi \leq 0.1</math></td> <td>Ignore</td> </tr> <tr> <td><math>0.10 &lt; \Phi \leq 0.20</math></td> <td>2</td> </tr> <tr> <td><math>0.20 &lt; \Phi</math></td> <td>0</td> </tr> </tbody> </table>	Zone Size(mm)	Acceptable Qty Including view area/ BM area of front surface	$\Phi \leq 0.1$	Ignore	$0.10 < \Phi \leq 0.20$	2	$0.20 < \Phi$	0	Minor
Zone Size(mm)	Acceptable Qty Including view area/ BM area of front surface										
$\Phi \leq 0.1$	Ignore										
$0.10 < \Phi \leq 0.20$	2										
$0.20 < \Phi$	0										
5.2.7	Glass defect (i)Chips on corner	A:LCD Glass defect    <table border="1"> <thead> <tr> <th>X</th> <th>Y</th> <th>Z</th> </tr> </thead> <tbody> <tr> <td><math>\leq 2.0</math></td> <td><math>\leq S</math></td> <td>Disregard</td> </tr> </tbody> </table> Notes: S=contact pad length Chips on the corner of terminal shall not be allowed to extend into the ITO pad or expose perimeter seal.	X	Y	Z	$\leq 2.0$	$\leq S$	Disregard			
X	Y	Z									
$\leq 2.0$	$\leq S$	Disregard									
		B:CTP Glass defect  <table border="1"> <thead> <tr> <th>Zone Size(mm)</th> <th>Acceptable Qty Including view area/ BM area of front surface</th> </tr> </thead> <tbody> <tr> <td><math>\Phi \leq 0.10</math></td> <td>Ignore</td> </tr> <tr> <td><math>0.10 &lt; \Phi \leq 0.20</math></td> <td>2</td> </tr> <tr> <td><math>0.20 &lt; \Phi</math></td> <td>0</td> </tr> </tbody> </table>	Zone Size(mm)	Acceptable Qty Including view area/ BM area of front surface	$\Phi \leq 0.10$	Ignore	$0.10 < \Phi \leq 0.20$	2	$0.20 < \Phi$	0	Minor
Zone Size(mm)	Acceptable Qty Including view area/ BM area of front surface										
$\Phi \leq 0.10$	Ignore										
$0.10 < \Phi \leq 0.20$	2										
$0.20 < \Phi$	0										

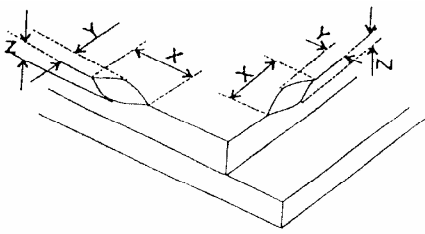
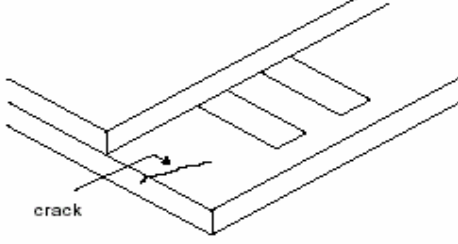

	<b>OUTGOING QUALITY STANDARD</b>	PAGE 8 OF 10 Edition: D
TITLE:FUNCTIONAL TEST & INSPECTION CRITERIA		within 4.5" I-touch module Product



Item No	Items to be inspected	Inspection Standard	Classification of defects							
5.2.7	Glass defect (ii)Usual surface cracks	A:LCD Glass defect  <table border="1" style="margin-top: 10px; width: 100%;"> <tr> <td style="text-align: center;">X</td> <td style="text-align: center;">Y</td> <td style="text-align: center;">Z</td> </tr> <tr> <td style="text-align: center;"><math>\leq 3.0</math></td> <td style="text-align: center;">&lt;Inner border line of the seal</td> <td style="text-align: center;">Disregard</td> </tr> </table>	X	Y	Z	$\leq 3.0$	<Inner border line of the seal	Disregard	Minor	
		X	Y	Z						
	$\leq 3.0$	<Inner border line of the seal	Disregard							
B:CTP Glass defect <table border="1" style="width: 100%; margin-top: 10px;"> <thead> <tr> <th style="text-align: center;">Zone</th> <th style="text-align: center;">Acceptable Qty</th> </tr> </thead> <tbody> <tr> <td style="text-align: center;">Size(mm)</td> <td style="text-align: center;">Including view area/ BM area of front surface</td> </tr> <tr> <td style="text-align: center;"><math>\Phi \leq 0.10</math></td> <td style="text-align: center;">Ignore</td> </tr> <tr> <td style="text-align: center;"><math>0.10 &lt; \Phi \leq 0.20</math></td> <td style="text-align: center;">2</td> </tr> <tr> <td style="text-align: center;"><math>0.20 &lt; \Phi</math></td> <td style="text-align: center;">0</td> </tr> </tbody> </table>	Zone	Acceptable Qty	Size(mm)	Including view area/ BM area of front surface	$\Phi \leq 0.10$	Ignore	$0.10 < \Phi \leq 0.20$	2	$0.20 < \Phi$	0
Zone	Acceptable Qty									
Size(mm)	Including view area/ BM area of front surface									
$\Phi \leq 0.10$	Ignore									
$0.10 < \Phi \leq 0.20$	2									
$0.20 < \Phi$	0									
Glass defect (iii) Crack 	Major									

	OUTGOING QUALITY STANDARD	PAGE 9 OF 10 Edition: D
TITLE:FUNCTIONAL TEST & INSPECTION CRITERIA		within 4.5" I-touch module Product

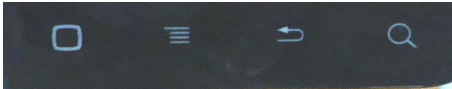
Item No	Items to be inspected	Inspection Standard	Classification of defects
5.28	Parts alignment	1) Not allow IC and FPC/heat-seal lead width is more than 50% beyond lead pattern. 2) Not allow chip or solder component is off center more than 50% of the pad outline.	Minor
5.2.9	SMT	According to the <Acceptability of electronic assemblies> IPC-A-610C class 2 standard. Component missing or function defect are Major defect, the others are Minor defect.	

### 5.3 Other Defect of CTP

Item No	Items to be inspected	Inspection Standard	Zone
5.3.1	Pattern font	<div style="text-align: center;">  </div> <ol style="list-style-type: none"> <li>1. Dot : according Dot spec</li> <li>2. Drawing slant:                          Print pattern length<math>\leq</math>10mm, slant angle<math>\leq</math>3°;                          10mm&lt;Print pattern length<math>\leq</math>20mm, slant angle<math>\leq</math>1.5°                     </li> </ol> <div style="text-align: center;">  </div> <ol style="list-style-type: none"> <li>3. Pattern serration: H<math>\leq</math>0.05mm</li> <li>4. Pattern leak print/ error/overprint, not allow.</li> <li>5. Pattern break line, width <math>\leq</math>0.10mm.</li> <li>6. Logo pattern color windage /color thin Follow the limit samples.</li> <li>7. Thickness odds<math>\leq</math>30%</li> </ol> <div style="border: 1px solid black; padding: 5px; margin-top: 10px;"> <p>Thickness odds =ABS (Spec pattern width - Print pattern width) x100% / Spec pattern width</p> <p>粗细不均: 用标准图文字宽与印刷图文字宽差值的绝对值相对于标准图文字宽的百分比来表示。</p> </div>	Including view area/ BM area of front surface

 OUTGOING QUALITY STANDARD		PAGE 10 OF 10 Edition: D	
TITLE:FUNCTIONAL TEST & INSPECTION CRITERIA		within 4.5" I-touch module Product	
Item No	Items to be inspected	Inspection Standard	Zone
5.3.2	Water ripples	If the Water ripples comes after pressed by the pressure of within 250 g , it's not allowed.	Including view area/ BM area of front surface
5.3.3	IR hole, (A)/ light sensor hole(B)/ LED hole(C)	 <ol style="list-style-type: none"> <li>1. A.B.C hole must be according the transmittancy</li> <li>2. Light leakage on A.B.C hole or follow the limited sample.</li> <li>3. A.B.C hole (LED) hole only judge by black background, no need to check in the lamb condition.</li> </ol>	
5.3.4	Surface dirty	<ol style="list-style-type: none"> <li>1. Dirty can not be cleaned follow the spec of dot.</li> <li>2. Accept while the dirty can be cleaned.</li> <li>3. The quality guarantee period of protective film is 3months, during the period, the spot or contamination is not allowed.</li> </ol>	
5.3.5	Printing area Light leakage	Follow the dot defect spec, MAX, Severity –see light leakage limit sample	
5.3.6	Ink overflow	Visual inspection 30cm not allowed	
5.3.7	Color discordant	Obvious color difference in the BM area is not allowed	
5.3.8	Icon scratch of printing logo area	Icon printing logo area not allow penetrability scratch	
5.3.9	Fiber Inclusion	Accept when the defects can't be seen in the front View Area.	
	Stain		
	Scratch		
	PC sheet		
	Bubble		
	Side check		

## ■ PRECAUTIONS FOR USING LCD MODULES

### 1 Handling Precautions

- 1.1 The display panel is made of glass and polarizer. As glass is fragile. It tends to become or chipped during handling especially on the edges. Please avoid dropping or jarring. Do not subject it to a mechanical shock by dropping it or impact.
- 1.2 If the display panel is damaged and the liquid crystal substance leaks out, be sure not to get any in your mouth. If the substance contacts your skin or clothes, wash it off using soap and water.
- 1.3 Do not apply excessive force to the display surface or the adjoining areas since this may cause the color tone to vary. Do not touch the display with bare hands. This will stain the display area and degraded insulation between terminals (some cosmetics are determined to the polarizer).
- 1.4 The polarizer covering the display surface of the LCD module is soft and easily scratched. Handle this polarizer carefully. Do not touch, push or rub the exposed polarizers with anything harder than an HB pencil lead (glass, tweezers, etc.). Do not put or attach anything on the display area to avoid leaving marks on it. Condensation on the surface and contact with terminals due to cold will damage, stain or dirty the polarizer. After products are tested at low temperature they must be warmed up in a container before coming in to contact with room temperature air.
- 1.5 If the display surface becomes contaminated, breathe on the surface and gently wipe it with a soft dry cloth. If it is heavily contaminated, moisten cloth with one of the following solvents
  - Isopropyl alcohol
  - Ethyl alcoholDo not scrub hard to avoid damaging the display surface.
- 1.6 Solvents other than those above-mentioned may damage the polarizer. Especially, do not use the following.
  - Water
  - Ketone
  - Aromatic solventsWipe off saliva or water drops immediately, contact with water over a long period of time may cause deformation or color fading. Avoid contact with oil and fats.
- 1.7 Exercise care to minimize corrosion of the electrode. Corrosion of the electrodes is accelerated by water droplets, moisture condensation or a current flow in a high-humidity environment.
- 1.8 Install the LCD Module by using the mounting holes. When mounting the LCD module make sure it is free of twisting, warping and distortion. In particular, do not forcibly pull or bend the I/O cable or the backlight cable.
- 1.9 Do not attempt to disassemble or process the LCD module.
- 1.10 NC terminal should be open. Do not connect anything.
- 1.11 If the logic circuit power is off, do not apply the input signals.
- 1.12 Electro-Static Discharge Control, Since this module uses a CMOS LSI, the same careful attention should be paid to electrostatic discharge as for an ordinary CMOS IC. To prevent destruction of the elements by static electricity, be careful to maintain an optimum work environment.
  - Before removing LCM from its packing case or incorporating it into a set, be sure the module and your body have the same electric potential. Be sure to ground the body when handling the LCD modules.

- Tools required for assembling, such as soldering irons, must be properly grounded. Make certain the AC power source for the soldering iron does not leak. When using an electric screwdriver to attach LCM, the screwdriver should be of ground potentiality to minimize as much as possible any transmission of electromagnetic waves produced sparks coming from the commutator of the motor.

- To reduce the amount of static electricity generated, do not conduct assembling and other work under dry conditions. To reduce the generation of static electricity be careful that the air in the work is not too dry. A relative humidity of 50%-60% is recommended. As far as possible make the electric potential of your work clothes and that of the work bench the ground potential.

- The LCD module is coated with a film to protect the display surface. Exercise care when peeling off this protective film since static electricity may be generated.

1.13 Since LCM has been assembled and adjusted with a high degree of precision, avoid applying excessive shocks to the module or making any alterations or modifications to it.

- Do not alter, modify or change the shape of the tab on the metal frame.
- Do not make extra holes on the printed circuit board, modify its shape or change the positions of components to be attached.
- Do not damage or modify the pattern writing on the printed circuit board.
- Absolutely do not modify the zebra rubber strip (conductive rubber) or heat seal connector.
- Except for soldering the interface, do not make any alterations or modifications with a soldering iron.
- Do not drop, bend or twist the LCM.

**2 Handling precaution for LCM**

**2.1 LCM is easy to be damaged. Please note below and be careful for handling.**

**2.2 Correct handling:**



As above picture, please handle with anti-static gloves around LCM edges.

**2.3 Incorrect handling:**



Please don't touch IC directly.

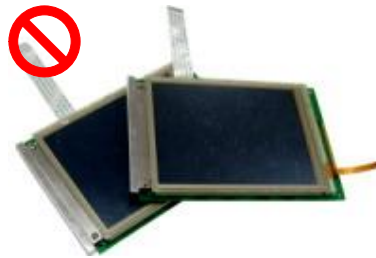

Please don't stack LCM.



Please don't hold the surface of panel.

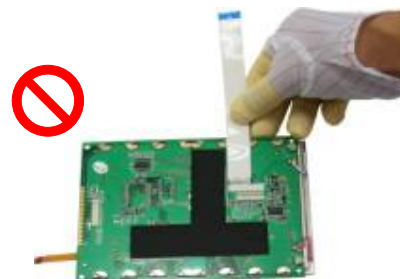

Please don't stretch interface of output, such as FPC cable.

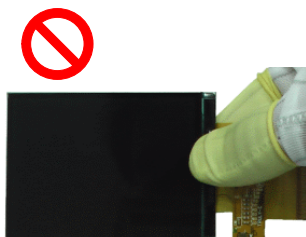

Please don't hold the surface of IC.

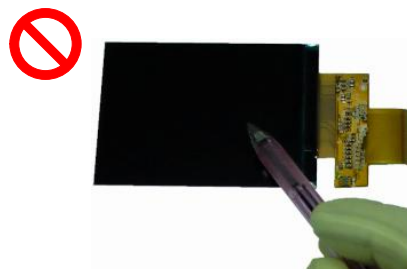

Please don't operate with sharp stick such as pens.



### 3 Storage Precautions

3.1 When storing the LCD modules, the following precaution are necessary.

3.1.1 Store them in a sealed polyethylene bag. If properly sealed, there is no need for the desiccant.

3.1.2 Store them in a dark place. Do not expose to sunlight or fluorescent light, keep the temperature between 0°C and 35°C, and keep the relative humidity between 40%RH and 60%RH.

3.1.3 The polarizer surface should not come in contact with any other objects (We advise you to store them in the anti-static electricity container in which they were shipped)

3.2 Transportation Precautions

3.2.1 During shipment, please handle with care. The packaging bag can not be broken, step on trap. Packaging Carton layer height can not be over two meters.

3.2.2 The transportation process should pay attention to the waterproof and moisture-proof measures. Product can not be watering. Ethylene sealed bags can not be unsealed.

3.3 Others

3.3.1 Liquid crystals solidify under low temperature (below the storage temperature range) leading to defective orientation or the generation of air bubbles (black or white). Air bubbles may also be generated if the module is subject to a low temperature.

3.3.2 If the LCD modules have been operating for a long time showing the same display patterns, the display patterns may remain on the screen as ghost images and a slight contrast irregularity may also appear. A normal operating status can be regained by suspending use for some time. It should be noted that this phenomenon does not adversely affect performance reliability.

3.3.3 To minimize the performance degradation of the LCD modules resulting from destruction caused by static electricity etc., exercise care to avoid holding the following sections when handling the modules.

3.3.3.1 - Exposed area of the printed circuit board.

3.3.3.2 -Terminal electrode sections.

### 4 USING LCD MODULES

4.1 Installing LCD Modules

The hole in the printed circuit board is used to fix LCM as shown in the picture below. Attend to the following items when installing the LCM.

4.1.1 Cover the surface with a transparent protective plate to protect the polarizer and LC cell.

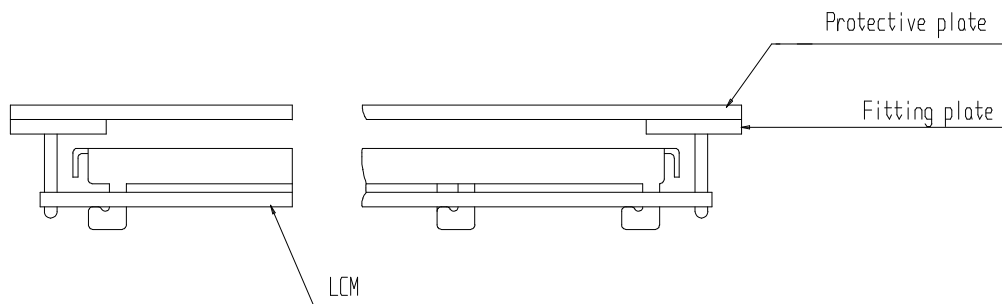

4.1.2 When assembling the LCM into other equipment, the spacer to the bit between the LCM and the fitting plate should have enough height to avoid causing stress to the module surface, refer to the individual specifications for measurements. The measurement tolerance should be  $\pm 0.1\text{mm}$ .

4.2 Precaution for assemble the module with BTB connector:

Please note the position of the male and female connector position, don't assemble or assemble like the method which the following picture shows

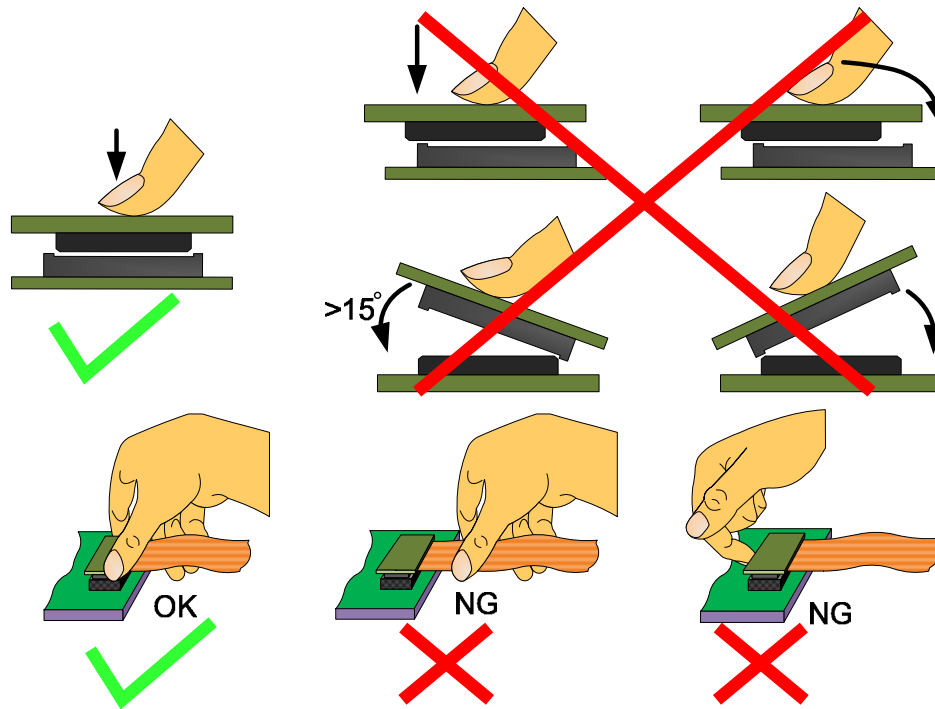

### 4.3 Precaution for soldering the LCM

	Manual soldering	Machine drag soldering	Machine press soldering
No RoHS Product	290°C ~350°C. Time : 3-5S.	330°C ~350°C. Speed : 4-8 mm/s.	300°C ~330°C. Time : 3-6S. Press: 0.8~1.2Mpa
RoHS Product	340°C ~370°C. Time : 3-5S.	350°C ~370°C. Time : 4-8 mm/s.	330°C ~360°C. Time : 3-6S. Press: 0.8~1.2Mpa

4.3.1 If soldering flux is used, be sure to remove any remaining flux after finishing to soldering operation (This does not apply in the case of a non-halogen type of flux). It is recommended that you protect the LCD surface with a cover during soldering to prevent any damage due to flux spatters.

4.3.2 When soldering the electroluminescent panel and PC board, the panel and board should not be detached more than three times. This maximum number is determined by the temperature and time conditions mentioned above, though there may be some variance depending on the temperature of the soldering iron.

4.3.3 When remove the electroluminescent panel from the PC board, be sure the solder has completely melted, the soldered pad on the PC board could be damaged.

### 4.4 Precautions for Operation

4.4.1 Viewing angle varies with the change of liquid crystal driving voltage (VLCD). Adjust VLCD to show the best contrast.

4.4.2 It is an indispensable condition to drive LCD's within the specified voltage limit since the higher voltage then the limit cause the shorter LCD life. An electrochemical reaction due to direct current causes LCD's undesirable deterioration, so that the use of direct current drive should be avoided.

4.4.3 Response time will be extremely delayed at lower temperature than the operating temperature range and on the other hand at higher temperature LCD's show dark color in them. However those phenomena do not mean malfunction or out of order with LCD's, which will come back in the specified operating temperature.

4.4.4 If the display area is pushed hard during operation, the display will become abnormal. However, it will return to normal if it is turned off and then back on.

4.4.5 A slight dew depositing on terminals is a cause for electro-chemical reaction resulting in terminal open circuit. Usage under the maximum operating temperature, 50%RH or less is required.

4.4.6 Input logic voltage before apply analog high voltage such as LCD driving voltage when power on. Remove analog high voltage before logic voltage when power off the module. Input each signal after the positive/negative voltage becomes stable.

4.4.7 Please keep the temperature within the specified range for use and storage. Polarization degradation, bubble generation or polarizer peel-off may occur with high temperature and high humidity.

### 4.5 Safety

4.5.1 It is recommended to crush damaged or unnecessary LCDs into pieces and wash them off with solvents such as acetone and ethanol, which should later be burned.

4.5.2 If any liquid leaks out of a damaged glass cell and comes in contact with the hands, wash off thoroughly with soap and water.

#### 4.6 Limited Warranty

Unless agreed between Multi-Inno and the customer, Multi-Inno will replace or repair any of its LCD modules which are found to be functionally defective when inspected in accordance with Multi-Inno LCD acceptance standards (copies available upon request) for a period of one year from date of production. Cosmetic/visual defects must be returned to Multi-Inno within 90 days of shipment. Confirmation of such date shall be based on data code on product. The warranty liability of Multi-Inno limited to repair and/or replace on the terms set forth above. Multi-Inno will not be responsible for any subsequent or consequential events.

#### 4.7 Return LCM under warranty

4.7.1 No warranty can be granted if the precautions stated above have been disregarded. The typical examples of violations are :

4.7.1.1 - Broken LCD glass.

4.7.1.2 - PCB eyelet is damaged or modified.

4.7.1.3 - PCB conductors damaged.

4.7.1.4 - Circuit modified in any way, including addition of components.

4.7.1.5 - PCB tampered with by grinding, engraving or painting varnish.

4.7.1.6 - Soldering to or modifying the bezel in any manner.

4.7.2 Module repairs will be invoiced to the customer upon mutual agreement. Modules must be returned with sufficient description of the failures or defects. Any connectors or cable installed by the customer must be removed completely without damaging the PCB eyelet, conductors and terminals.

### ■ PACKING SPECIFICATION

Please consult our technical department for detail information.

### ■ PRIOR CONSULT MATTER

- 1 For Multi-Inno standard products, we keep the right to change material, process ... for improving the product property without prior notice to our customer.
- 2 For OEM products, if any changes are needed which may affect the product property, we will consult with our customer in advance.
- 3 If you have special requirement about reliability condition, please let us know before you start the test on our samples.