



FORMIKE ELECTRONIC CO.,LTD

PRDUCT SPECIFICATON

TFT LCD MODULE

MODEL NO. : KWH070TG18-F01

Preliminary Specification

Finally Specification

CUSTOMER'S APPROVAL	
SIGNATURE:	DATE:

APPROVED BY	PM REVIEWD	PD REVIEWD	PREPARED BY
Ken	Lily	Stephen	Jack

Prepared By :

FORMIKE ELECTRONIC CO.,LTD

Address :Room A818 New Energy Building, NanHai Road, NanShan District, ShenZhen, China. 518054

TEL:(86) 755 88306921,88306931 FAX:(86) 755 88304615

Http:// www.wandisplay.com

- This specification is subject to change withouth notice.Please contact FORMIKE or it's representative before designing your product based on this specification.

Issued Date: Aug-12-2008



Table of Contents

Coversheet.....	1
Table of Contents	2
Record of Revision.....	3
1 General specifications.....	4
2 Input/Output terminals.....	5
3 Absolute maximum ratings.....	7
4 Electrical characteristics.....	8
5 Timing chart	10
6 Optical characteristics.....	13
7 Environmental / Reliability tests	17
8 Mechanical drawing	18
9 Packing drawing.....	19
10 Precautions for use of LCD modules.....	20

Formike Electronic Co., Ltd.



Record of Revision

Rev	Issued Date	Description
1.0	2008-07-10	Preliminary Release
1.1	2008-08-22	Change the Pin's definition of FPC and the length of B/L power cord



1 General specifications

Feature		Spec
Display Spec.	Size	7 inch
	Resolution	800(RGB) X 600
	Interface	Digital 18 bit RGB
	Color Depth	262k
	Technology type	a-si TFT
	Pixel pitch (mm)	0.18 X 0.18
	Pixel Configuration	R.G.B. Vertical Stripe
	Display Mode	Normally White
	Surface Treatment(Up Polarizer)	Anti-Glare
	Viewing Direction	12 o'clock
	Gray Scale Inversion Direction	6 o'clock
Mechanical Characteristics	DIM. LCM (W x H x D) (mm)	155.50 X 118.70 X 5.70
	Active Area(mm)	141.00 X 105.75
	With /Without TSP	Without TSP
	Weight (gram)	TBD
	LED Numbers	18 LEDs (3 LED Serial, 6LED Parallel)

Note 1 : Viewing direction for best image quality is different from TFT definition, there is a 180 degree shift.

Note 2 : Requirements on Environmental Protection: ROHS



2 Input/Output terminals

No	Symbol	I/O	Description	Comment
1	POL	I	Polarity selection	
2	STVD	I/O	Vertical start pulse input when U/D= H	Note 1
3	OEV	I	Output enable	
4	CKV	I	Vertical clock	
5	STVU	I/O	Vertical start pulse input when U/D= L	Note 1
6	GND	P	Power ground	
7	EDGSL	I	Select rising edge or falling edge	
8	VCC	P	Power supply for digital circuit	
9	V9	I	Gamma voltage level 9	
10	VGL	P	Gate OFF voltage	
11	V2	I	Gamma voltage level 2	
12	VGH	P	Gate ON voltage	
13	V6	I	Gamma voltage level 6	
14	U/D	I	Up/down selection	
15	VCOM	I	Common voltage	
16	GND	P	Power ground	
17	AVDD	P	Power supply for analog circuit	
18	V14	I	Gamma voltage level 14	
19	V11	I	Gamma voltage level 11	
20	V8	I	Gamma voltage level 8	
21	V5	I	Gamma voltage level 5	
22	V3	I	Gamma voltage level 3	
23	GND	P	Power ground	
24	R5	I	Red data(MSB)	
25	R4	I	Red data	
26	R3	I	Red data	
27	R2	I	Red data	
28	R1	I	Red data	
29	R0	I	Red data(LSB)	
30	GND	P	Power ground	
31	GND	P	Power ground	
32	G5	I	Green data(MSB)	
33	G4	I	Green data	
34	G3	I	Green data	
35	G2	I	Green data	
36	G1	I	Green data	
37	G0	I	Green data(LSB)	
38	STHL	I/O	Horizontal start pulse input when R/L = L	Note 1
39	REV	I	Control signal are inverted or not	
40	GND	I	Power ground	
41	DCLK	I	Sample clock	
42	VCC	P	Power supply for digital circuit	
43	STHR	I/O	Horizontal start pulse input when R/L= H	Note 1
44	LD	I	Latches the polarity of outputs and switches the new data to outputs	



45	B5	I	Blue data (MSB)	
46	B4	I	Blue data	
47	B3	I	Blue data	
48	B2	I	Blue data	
49	B1	I	Blue data	
50	B0	I	Blue data (LSB)	
51	R/L	I	Right/ left selection	Note 1
52	V1	I	Gamma voltage level 1	
53	V4	I	Gamma voltage level 4	
54	V7	I	Gamma voltage level 7	
55	V10	I	Gamma voltage level 10	
56	V12	I	Gamma voltage level 12	
57	V13	I	Gamma voltage level 13	
58	AVDD	P	Power supply for analog circuit	
59	GND	P	Power ground	
60	VCOM	I	Common voltage	

Note 1:

Setting		IN/OUT state for start pulse				Scanning direction
U/D	R/L	STVD	STVU	STHR	STHL	
GND	VCC	0	I	I	0	UP to down, left to right
VCC	GND	I	0	0	I	Down to up, right to left
GND	GND	0	I	0	I	UP to down, right to left
VCC	VCC	I	0	I	0	Down to up, left to right



3 Absolute maximum ratings

Ta = 25°C

Item	Symbol	MIN	MAX	Unit	Remark
Logic Supply Voltage	VCC	-0.3	5.0	V	
Analog Supply Voltage	AVDD	-0.3	15	V	
Positive power for scan driver	VGH	-0.3	42.0	V	
Negative power for scan driver	VGL	-20	0.3	V	
Voltage range of VGH- VGL	VGH- VGL	-0.3	40.0	V	
Gamma voltage	V1~V7	0.4 AVDD	AVDD+0.3	V	Note 1
	V8~V14	-0.3	0.6 AVDD	V	Note 1
Operating Temperature	T _{OPR}	-20	70	°C	
Storage Temperature	T _{STG}	-30	80	°C	

Note 1: AVDD-0.1 ≥ V1 ≥ V2 ≥ V3 ≥ V4 ≥ V5 ≥ V6 ≥ V7 ≥ V8 ≥ V9 ≥ V10 ≥ V11 ≥ V12 ≥ V13 ≥ V14 ≥ GND+0.1



4 Electrical characteristics

4.1. Driving TFT LCD Panel

GND=0V, Ta=25°C

Item	Symbol	MIN	TYP	MAX	Unit	Remark
Logic Supply Voltage	VCC	3.0	3.3	3.6	V	
Analog Supply Voltage	AVDD	-	10.0	-	V	
Positive power for scan driver	VGH	14.5	15	15.5		
Negative power for scan driver	VGL	-10.5	-10	-9.5		
Gamma voltage	V1~V7	0.4 AVDD	-	AVDD-0.1	V	
	V8~V14	0.1	-	0.6 AVDD	V	
VCOM	VCOM	-	4.05	-	V	
Input Signal Voltage	Low Level	V _{IL}	0	-	0.3*VCC	V
	High Level	V _{IH}	0.7*VCC	-	VCC	V
(Panel+LSI) Power Consumption	I _{GH}	-	TBD	-	mA	
	I _{GL}	-	TBD	-	mA	
	I _{CC}	-	TBD	-	mA	
	I _{AVDD}	-	TBD	-	mA	

Note: It is important that VCC & VGL should be applied before VGH.

4.2 . Driving Backlight

Ta=25°C

Item	Symbol	MIN	TYP	MAX	Unit	Remark
Forward Current	I _F	-	20	-	mA	Note 1
Forward Current Voltage	V _F	-	9.6	-	V	Note 1
Backlight Power Consumption	W _{BL}	-	1152	-	mW	Note 1

Note 1 : The LED driving condition is defined for all LED module (3 LED Serial, 6LED Parallel).

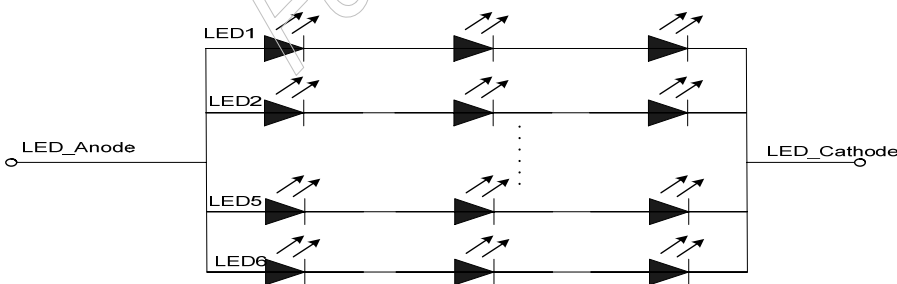



4.3. Power Sequence
4.3.1 Power on

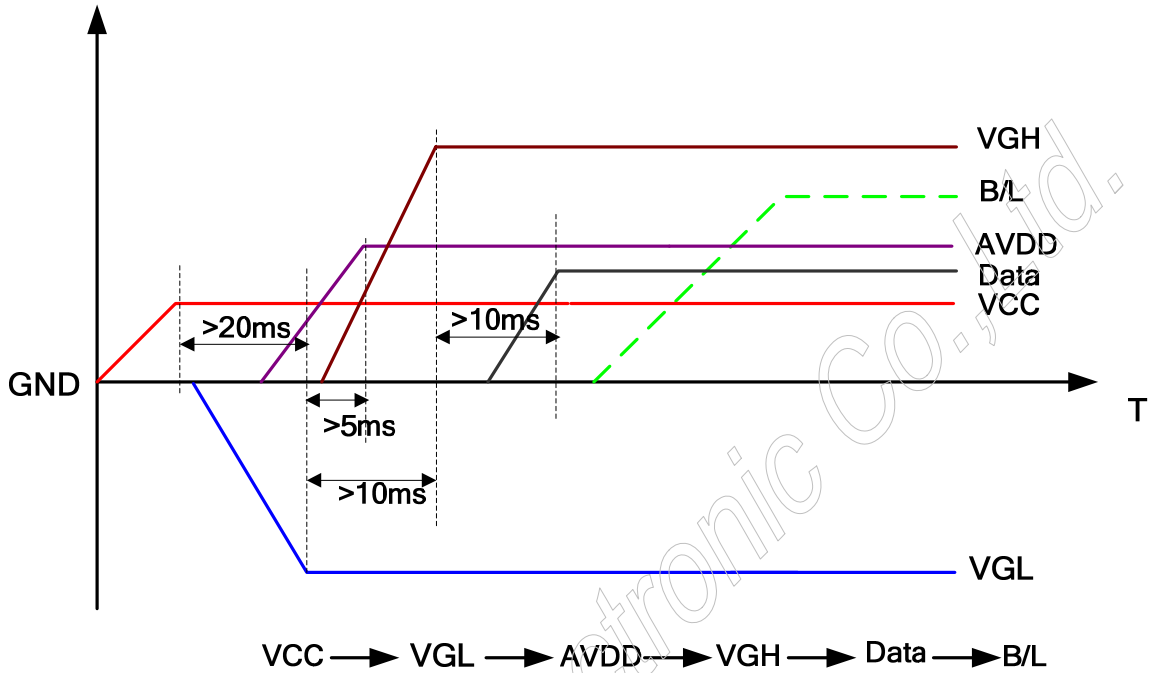

4.3.2 Power off

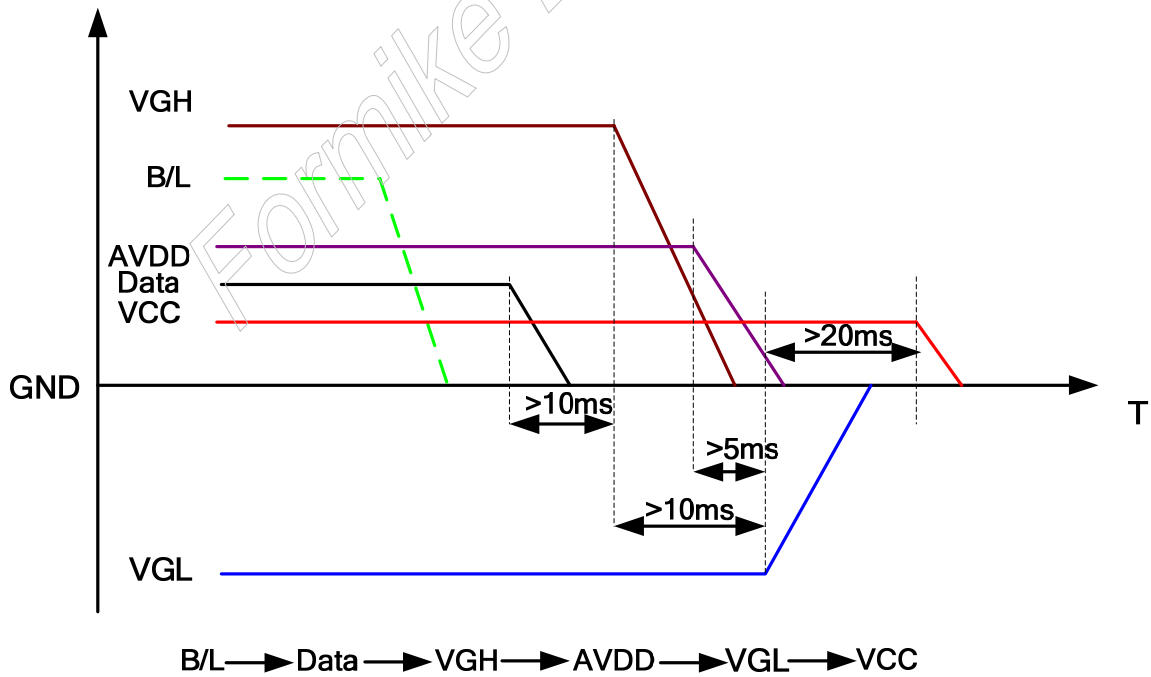



5 Timing chart

5.1.1. Clock and data input timing diagram1 (VCC=3.3V,AVDD=10.0V, GND=AGND=0V,Ta=25°C)

Parameter	Symbol	Min.	Typ.	Max.	Unit	Conditions
DCLK frequency	Fclk	-	50	55	MHz	EDGSL=0
		-	25	27.5	MHz	EDGSL=1
DCLK cycle	Tcph	18	20	-	ns	EDGSL=0
		36	40	-	ns	EDGSL=1
DCLK pulse width	Tcw	40%	-	60%	Tcph	
Data set-up time	Tsu	4	-	-	ns	
Data hold time	Thd	2	-	-	ns	
Time that the last data to LD	Tld	1	-	-	Tcph	
Pulse width of LD	Twld	2	-	-	Tcph	
Time that LD to STHL/R	Tlds	5	-	-	Tcph	
POL set-up time	Tpsu	6	-	-	ns	POL to LD
POL hold time	Tphd	6	-	-	ns	POL to LD
Horizontal display timing range	Tdh	-	800	-	Tcph	
Horizontal timing range	Th	-	1056	-	Tcph	
CKV pulse width	Pwclk	500	-	-	ns	High & Low
OEV pulse width	Twcl	1	-	-	us	
STVD/U set-up time	Tgsu	200	-	-	ns	
STVD/U hold time	Tghd	300	-	-	ns	
Horizontal lines per field	Tv	628	635	650	Tdh	
Vertical display timing range	Tvd	-	600	-	Tdh	



5.1.2. Clock and data input timing diagram1 (VCC=3.3V,AVDD=10.0V, GND=AGND=0V,Ta=25°C)

<< EDGSL="0" >>

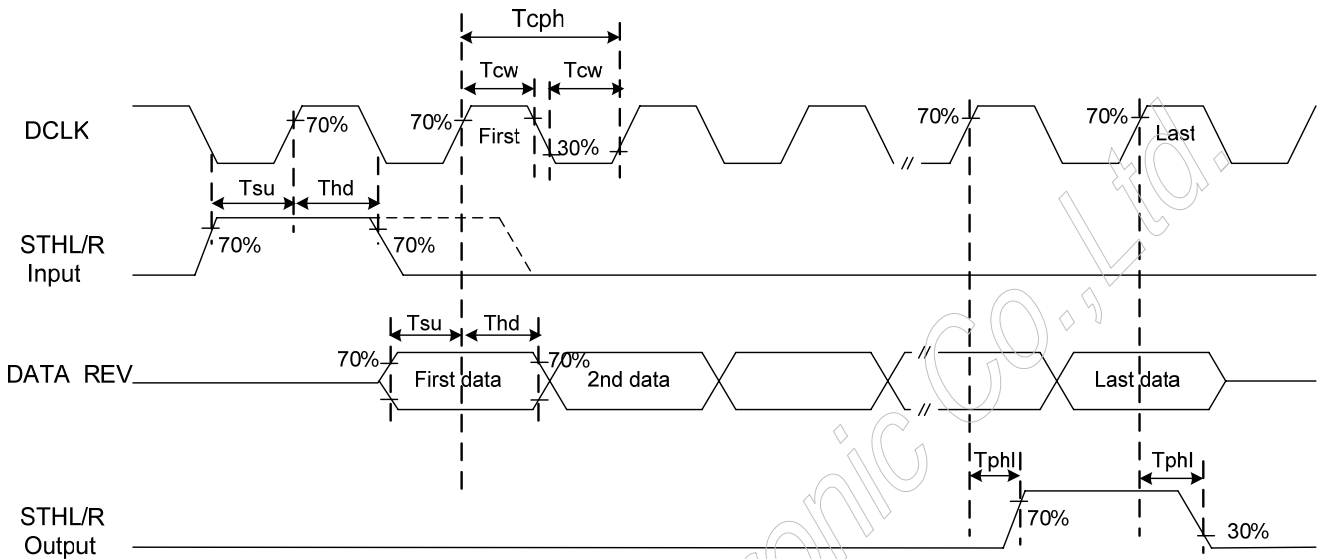

<< EDGSL="1" >>

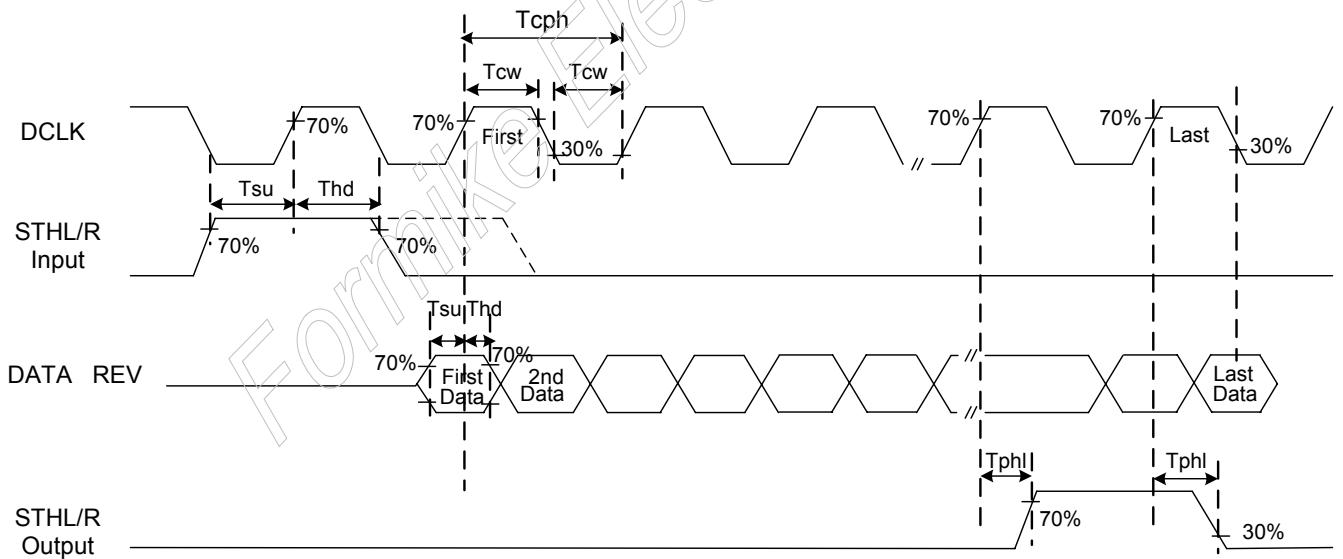



5.1.3. Clock and data input timing diagram2

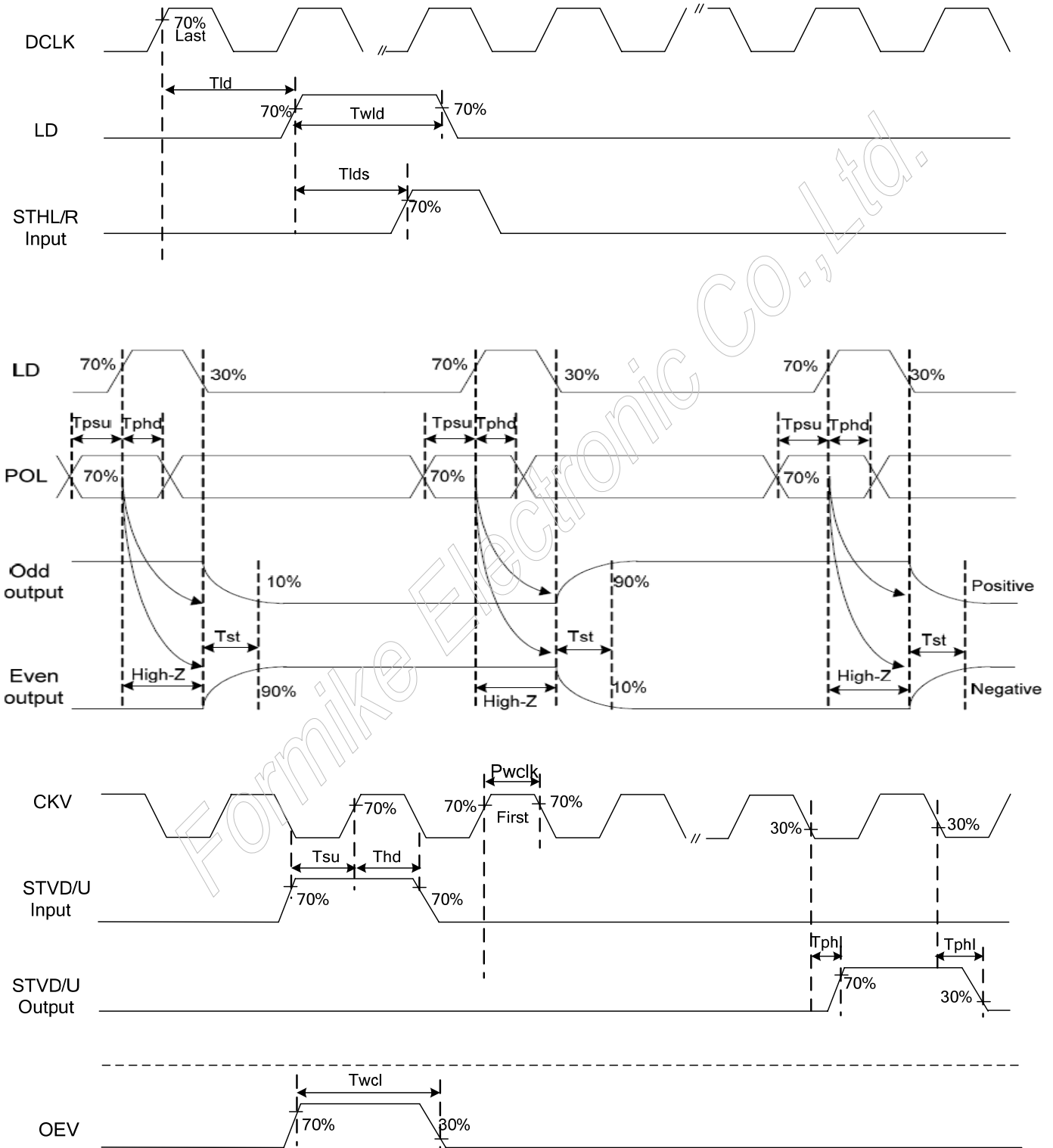



6 Optical characteristics

6.1 Optical Specification

Ta=25°C

Item	Symbol	Condition	Min	Typ.	Max.	Unit	Remark
View Angles	θ T	CR \geq 10	35	45	-	Degree	Note 2,3
	θ B		55	65	-		
	θ L		55	65	-		
	θ R		55	65	-		
Contrast Ratio	CR	$\theta = 0^\circ$	-	400	-		Note 3
Response Time	Ton	25°C	-	25	50	ms	Note 4
	Toff						
Chromaticity	White	x	-	0.310	-	Backlight on	Note 1,5
		y	-	0.330	-		
	RED	x	-	-	-		
		y	-	-	-		
	GREEN	x	-	-	-		
		y	-	-	-		
	BLUE	x	-	-	-		
		y	-	-	-		
Uniformity	U		70	80	-	%	Note 6
NTSC	(x,y)		45	50	-	%	Note 5
Luminance	L		160	200	-	cd/m ²	Note 7

Test Conditions:

1. The ambient temperature is 25°C.
2. The test systems refer to Note 1 and Note 2.



Note 1: Definition of optical measurement system.

The optical characteristics should be measured in dark room. After 5 minutes operation, the optical properties are measured at the center point of the LCD screen. All input terminals LCD panel must be ground when measuring the center area of the panel.

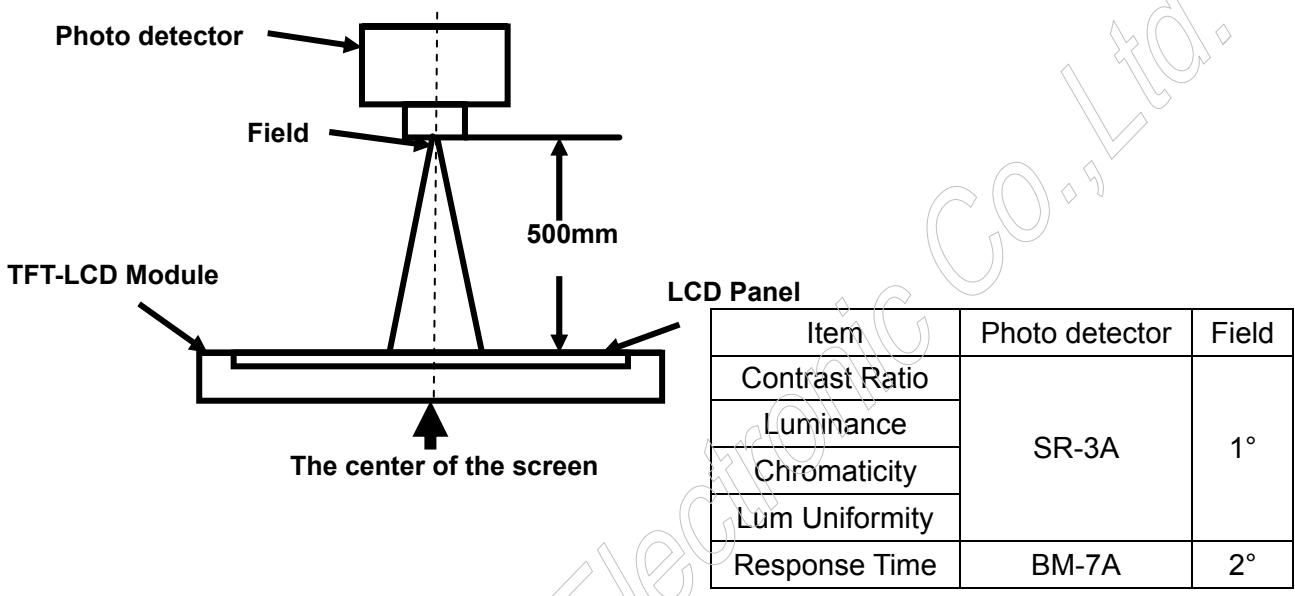

Note 2: Definition of viewing angle range and measurement system.

viewing angle is measured at the center point of the LCD by CONOSCOPE(ergo-80).

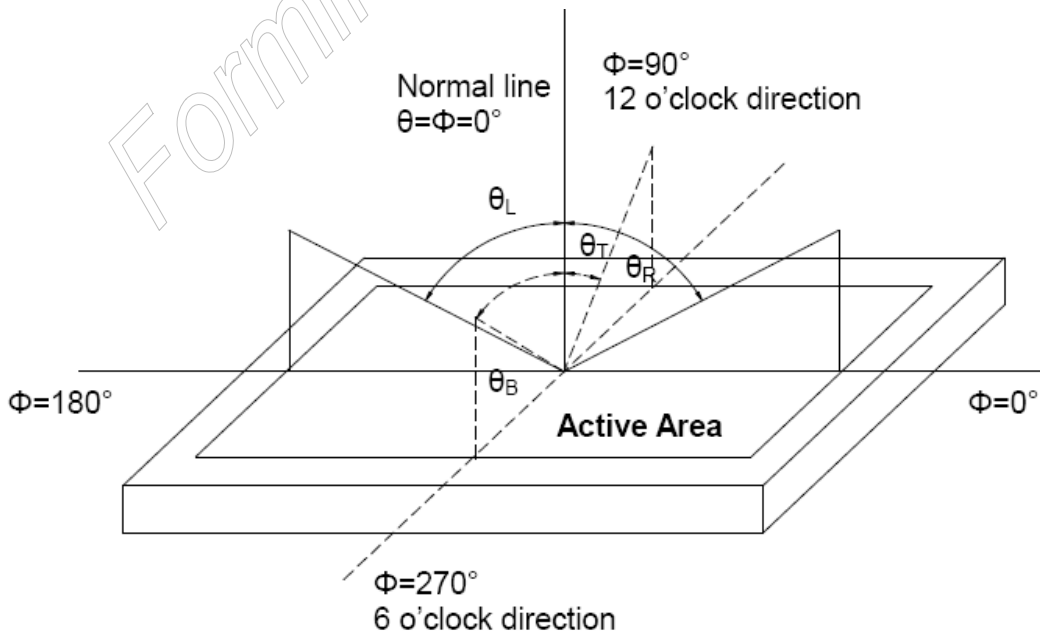

Fig. 6.1 Definition of viewing angle



Note 3: Definition of contrast ratio

$$\text{Contrast ratio (CR)} = \frac{\text{Luminance measured when LCD is on the "White" state}}{\text{Luminance measured when LCD is on the "Black" state}}$$

“White state “:The state is that the LCD should driven by Vwhite.

“Black state”: The state is that the LCD should driven by Vblack.

Vwhite: To be determined Vblack: To be determined.

Note 4: Definition of Response time

The response time is defined as the LCD optical switching time interval between “White” state and “Black” state. Rise time (TON) is the time between photo detector output intensity changed from 90% to 10%. And fall time (TOFF) is the time between photo detector output intensity changed from 10% to 90%.

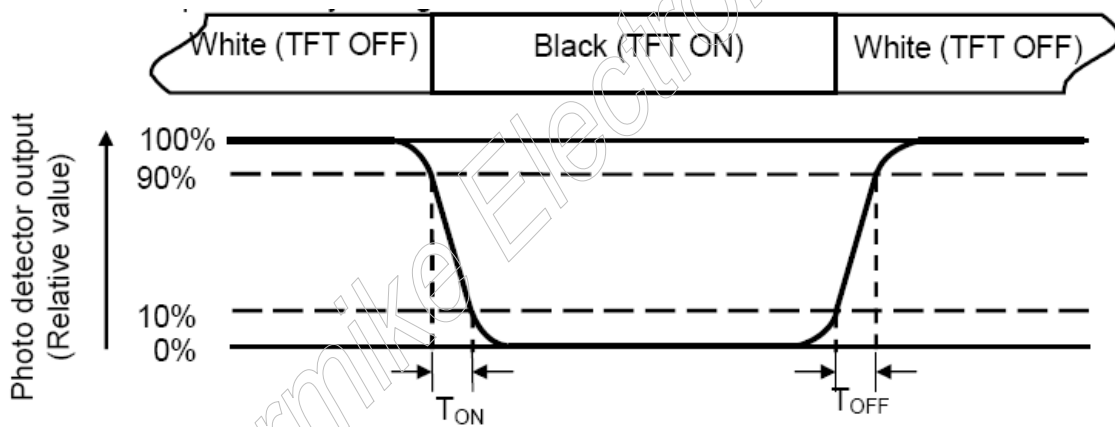

Note 5: Definition of color chromaticity (CIE1931)

Color coordinates measured at center point of LCD.



Note 6: Definition of Luminance Uniformity

Active area is divided into 9 measuring areas (Refer Fig. 2). Every measuring point is placed at the center of each measuring area.

Luminance Uniformity(U) = L_{min} / L_{max}

L-----Active area length W----- Active area width

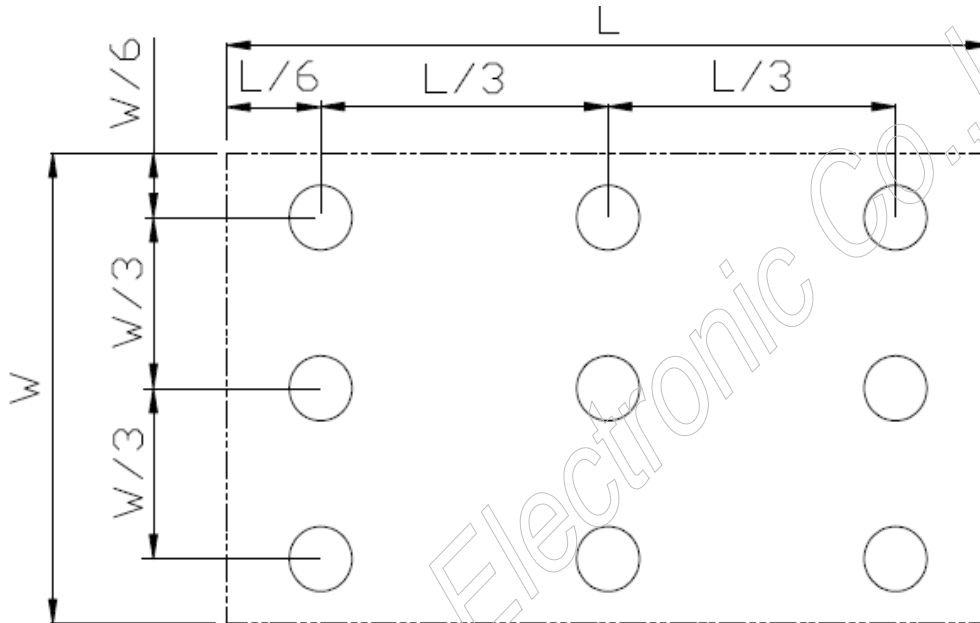

Fig. 6.2 Definition of uniformity

L_{max} : The measured maximum luminance of all measurement position.

L_{min} : The measured minimum luminance of all measurement position.

Note 7: Definition of Luminance :

Measure the luminance of white state at center point.

**7 Environmental / Reliability tests**

No	Test Item	Condition	Remarks
1	High Temperature Operation	Ts=+70°C, 240hrs	Note1 IEC60068-2-2,GB2423.2—89
2	Low Temperature Operation	Ta=-20°C, 240hrs	IEC60068-2-1 GB2423.1—89
3	High Temperature Storage (non-operation)	Ta=+80°C, 240hrs	IEC60068-2-2, GB2423.2—89
4	Low Temperature Storage (non-operation)	Ta=-30°C, 240hrs	IEC60068-2-1 GB2423.1—89
5	High Temperature & High Humidity Operation	Ta = +60 °C , 90% RH max,240 hours	Note2 IEC60068-2-3, GB/T2423.3—2006
6	Thermal Shock (non-operation)	-30°C 30 min~+80°C 30 min, Change time:5min, 100 Cycle	Start with cold temperature, end with high temperature IEC60068-2-14,GB2423.22—87
7	Electro Static Discharge (operation)	± 2KV,Human Body Mode, 100pF/1500 Ω	IEC61000-4-2 GB/T17626.2—1998
8	Vibration (non-operation)	Sine Wave Frequency range:10~55Hz, Stroke:1.5mm Sweep:10Hz~55Hz~10Hz 2 hours for each direction of X.Y.Z.(6 hours for total)	IEC60068-2-6 GB/T2423.10—1995
9	Shock (non-operation)	100G 6ms, ±X,±Y,±Z 3times for each direction	IEC60068-2-27 GB/T2423.5—1995
10	Package Drop Test	Height:80 cm, 1 corner, 3 edges, 6 surfaces	IEC60068-2-32 GB/2423.8—1995
11	Package Vibration Test	Random Vibration: 0.015G*G/Hz for 5-200Hz, -6dB/Octave from 200-500Hz 2 hours for each direction of X,Y,Z (6 hours for total)	IEC60068-2-34

Note1: Ts is the temperature of panel's surface.

Note2: Ta is the ambient temperature of samples.



8 Mechanical drawing

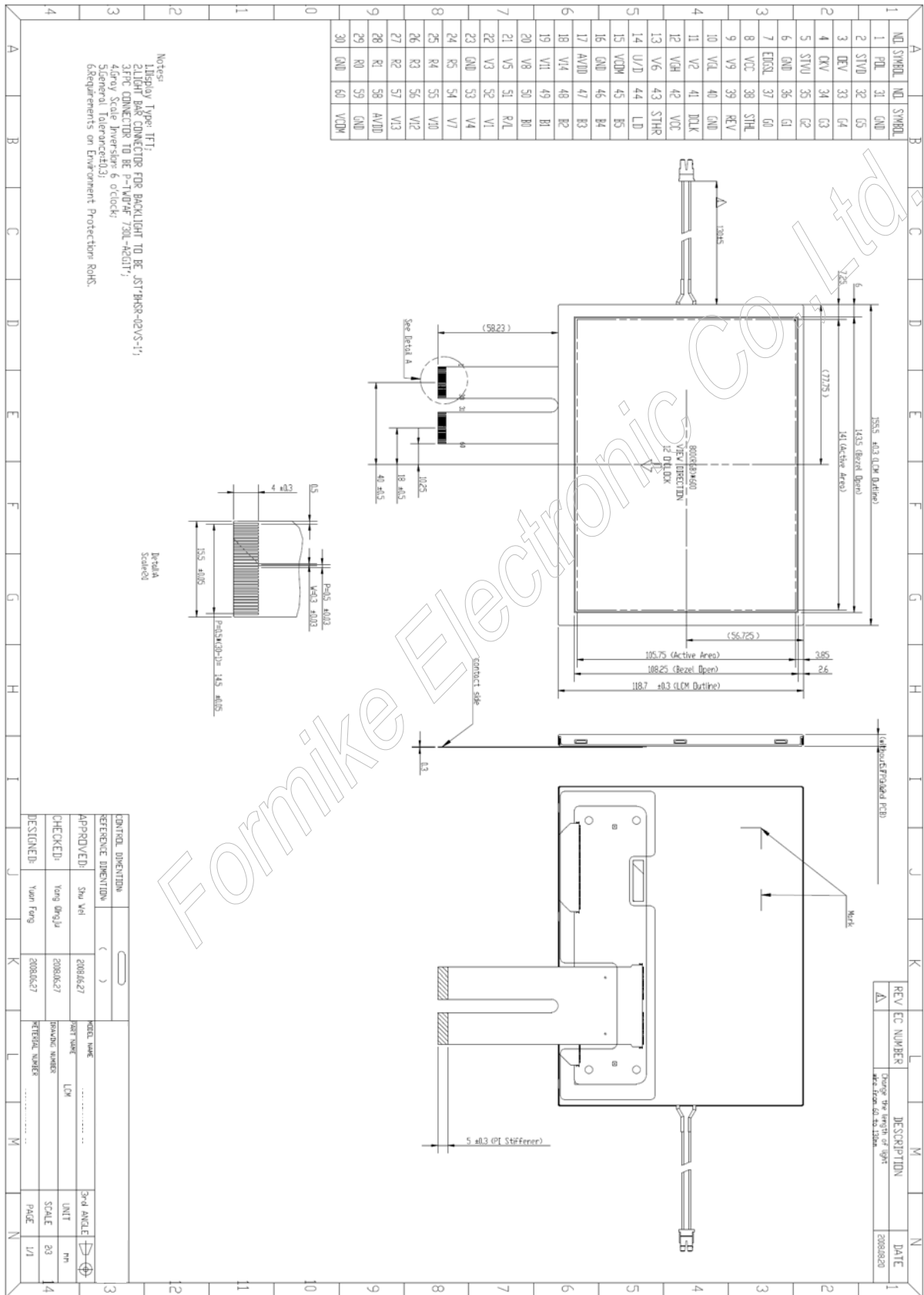

The information contained herein is the exclusive property of FORMIKE ELECTRONIC CO.,LTD and shall not be distributed, reproduced, or disclosed in whole or in part without prior written permission of Formike Electronic Co.,Ltd.



9 Packing drawing

No	Item	Model (Material)	Dimensions(mm)	Unit Weight(Kg)	Quantity	Remark
1	LCM module	KWH070TG18-F01	155.5*118.7*5.70	TBD	50	
2	Partition_1	Corrugated Paper	513*333*215	2.0	1	
3	Anti-Static Bag	PE	200*175	0.01	50	Anti-static
4	Dust-Proof Bag	PE	700*530	0.0600	1	
5	Partition_2	Corrugated Paper	505*332*4.00	0.1	2	
6	Corrugated Bar	Corrugated Paper	513*128*22.5	0.06	4	
7	Carton	Corrugated Paper	530*350*250	0.94	1	
8	Total weight	TBD				

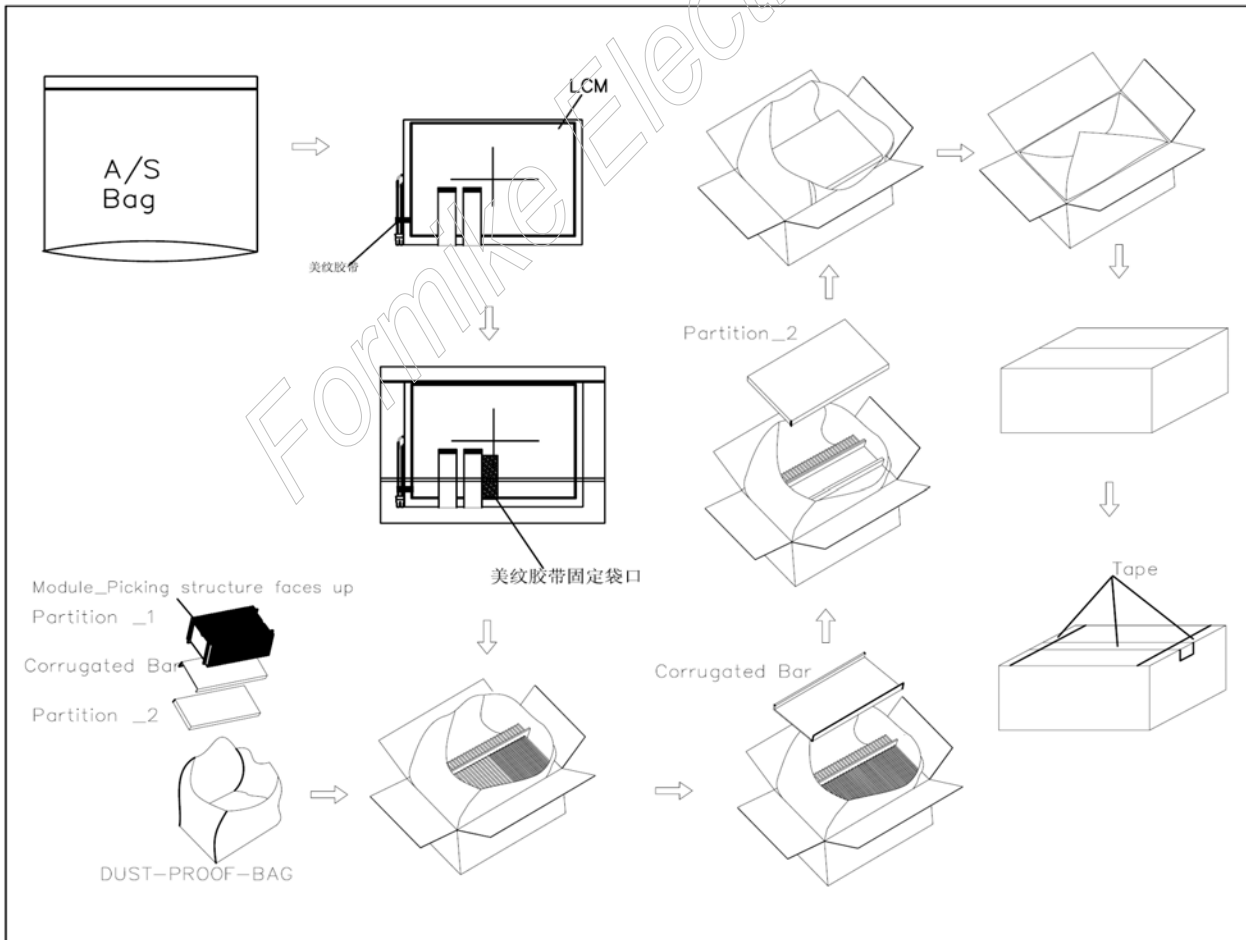



10 Precautions for use of LCD modules

10.1 Handling Precautions

- 10.1.1. The display panel is made of glass. Do not subject it to a mechanical shock by dropping it from a high place, etc.
- 10.1.2. If the display panel is damaged and the liquid crystal substance inside it leaks out, be sure not to get any in your mouth, if the substance comes into contact with your skin or clothes, promptly wash it off using soap and water.
- 10.1.3. Do not apply excessive force to the display surface or the adjoining areas since this may cause the color tone to vary.
- 10.1.4. The polarizer covering the display surface of the LCD module is soft and easily scratched. Handle this polarizer carefully.
- 10.1.5. If the display surface is contaminated, breathe on the surface and gently wipe it with a soft dry cloth. If still not completely clear, moisten cloth with one of the following solvents:
 - Isopropyl alcohol
 - Ethyl alcohol
- 10.1.6. Solvents other than those mentioned above may damage the polarizer. Especially, do not use the following:
 - Water
 - Ketone
 - Aromatic solvents
- 10.1.7. Do not attempt to disassemble the LCD Module.
- 10.1.8. If the logic circuit power is off, do not apply the input signals.
- 10.1.9. To prevent destruction of the elements by static electricity, be careful to maintain an optimum work environment.
- 10.2 Be sure to ground the body when handling the LCD Modules.
- 10.3 Tools required for assembly, such as soldering irons, must be properly ground.
- 10.4 To reduce the amount of static electricity generated, do not conduct assembly and other work under dry conditions.
- 10.5 The LCD Module is coated with a film to protect the display surface. Be care when peeling off this protective film since static electricity may be generated.
- 10.6 Storage precautions
 - 10.6.1. When storing the LCD modules, avoid exposure to direct sunlight or to the light of fluorescent lamps.
 - 10.6.2. The LCD modules should be stored under the storage temperature range. If the LCD modules will be stored for a long time, the recommend condition is:
- 10.7 Temperature : 0°C ~ 40°C Relatively humidity: ≤80%
 - 10.7.1. The LCD modules should be stored in the room without acid, alkali and harmful gas.
 - 10.7.2. Transportation Precautions
- 10.8 The LCD modules should be no falling and violent shocking during transportation, and also should avoid excessive press, water, damp and sunshine.