



**Display Future Ltd**

www.displayfuture.com

## **LCD MODULE SPECIFICATION**

**Model: DF-TFN0145FB-F1**

**This module uses ROHS materials**

### **For customer acceptance**

Customer		date
Approved		
Comments		

The standard product specification may change without prior notice in order to improve performance or quality. Please contact Display Future Ltd for updated specification and product status before design for the standard product or release of the order.

Revision	2.0
Engineering	
Date	2018/01/4
Our Reference	

**Revision record**

VEV NO.	REV DATE	CONTENTS	Note
<b>V1.0</b>	<b>2014-08-11</b>	<b>NEW ISSUE</b>	

## 1. General Description

### 1.1 Description

DF-TFN0241FB-F1 ver. 2.0 is a Transmissive type colour active matrix liquid crystal display (LCD), which uses amorphous thin film transistor (TFT) as switching devices. This product is composed of a TFT LCD panel, driver IC, FPC and backlight unit . The following table described the features of DF-TFN0241FB-F1 ver. 2.0.

### 1.2 Application

Mobile phone, Multimedia products  
and other electronic Products  
Etc.

### 1.3 Features:

Features	Description	UNITS
LCD type	2.4" TFT	--
Dot arrangement	240 (RGB) × 320	dots
Driver IC	ILI9341	--
Color Depth	65K	
Interface	CPU 16 bits	
Module size	42.72(W) × 60.26 (H) × 2.2(T)	mm
Active area	36.72(W) × 48.96(H)	mm
Dot pitch	0.153 (W) × 0.153 (H)	mm
Back Light	4 White LED In parallel	--
With/Without TSP	Without TSP	
Weight(g)	TBD	

## 2. External Dimensions

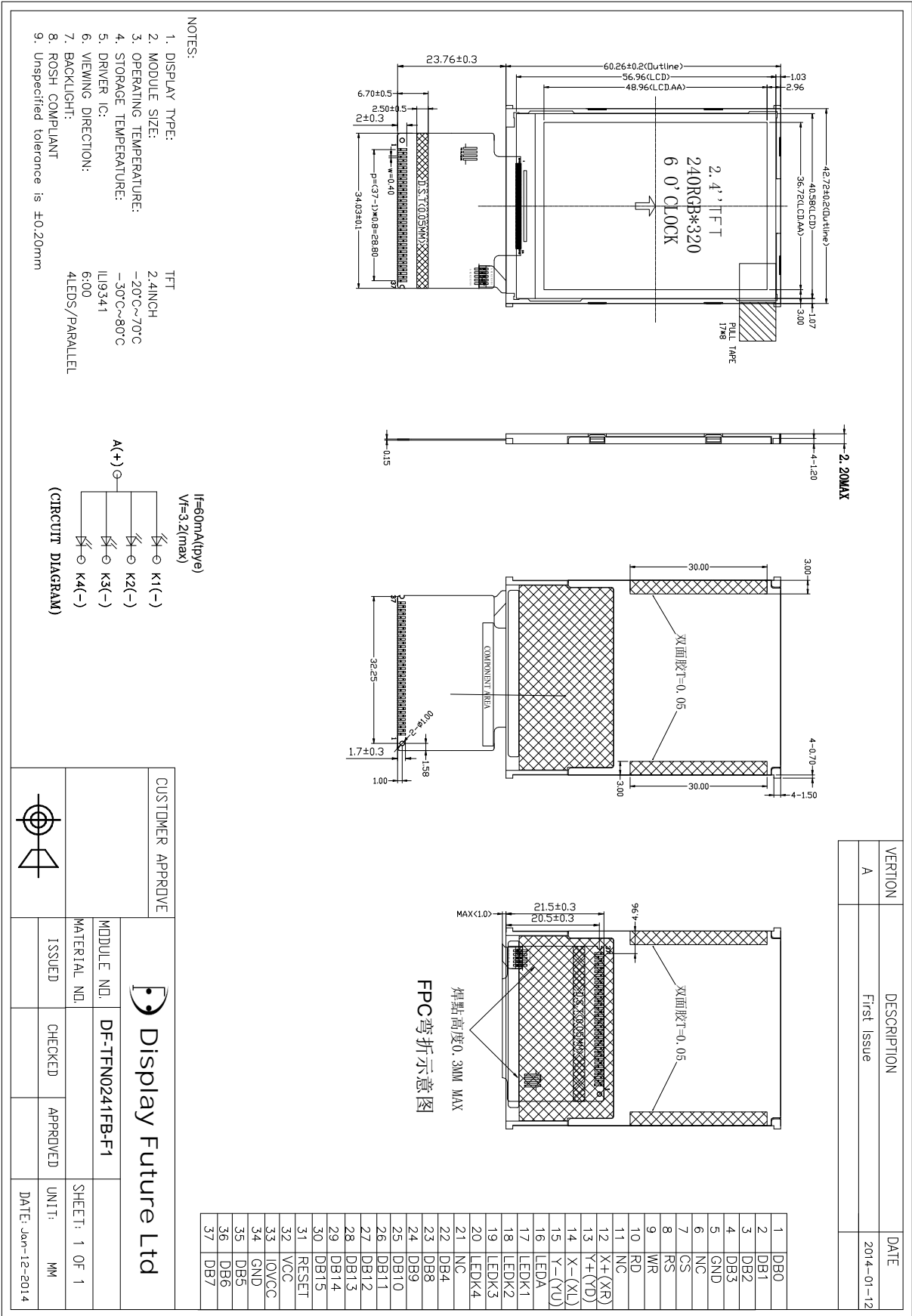

### 3. Interface Description

PIN NO.	PIN NAME	DESCRIPTION
1	DB0	80-system-16-Bit Data Bus.
2	DB1	80-system-16-Bit Data Bus.
3	DB2	80-system-16-Bit Data Bus.
4	DB3	80-system-16-Bit Data Bus.
5	GND	Ground
6	NC	NC
7	CS	Chip select signal, Active "L"
8	RS	Command / Display data selection 0: command; 1: display data
9	WR	Write signal input, Active" L "
10	RD	Read signal input, Active" L "
11	NC	NC
12	X+(XR)	Touch Panel Right Side Wire
13	Y+(YD)	Touch Panel Down Side Wire
14	X-(XL)	Touch Panel Left Side Wire
15	Y-(YU)	Touch Panel Up Side Wire
16	LED-A	Power supply for LED backlight Anode input
17	LED-K1	Power supply for LED backlight Cathode input
18	LED-K2	Power supply for LED backlight Cathode input
19	LED-K3	Power supply for LED backlight Cathode input
20	LED-K4	Power supply for LED backlight Cathode input
21	NC	NC.
22	DB4	80-system-16-Bit Data Bus.
23	DB8	80-system-16-Bit Data Bus.
24	DB9	80-system-16-Bit Data Bus.
25	DB10	80-system-16-Bit Data Bus.
26	DB11	80-system-16-Bit Data Bus.
27	DB12	80-system-16-Bit Data Bus.
28	DB13	80-system-16-Bit Data Bus.
29	DB14	80-system-16-Bit Data Bus.
30	DB15	80-system-16-Bit Data Bus.
31	RESET	Reset input pin, When reset is "L", Initialization is executed.
32	VCC	Power supply for analog(+2.5V~+3.3V).
33	IOVCC	Power supply logic(+1.8V~+3.3V).
34	GND	Ground
35	DB5	80-system-16-Bit Data Bus.
36	DB6	80-system-16-Bit Data Bus.
37	DB7	80-system-16-Bit Data Bus.

### 4. Absolute Maximum Ratings

The absolute maximum rating is listed on following table. When ILI9341 is used out of the absolute maximum ratings, ILI9341 may be permanently damaged. To use ILI9341 within the following electrical characteristics limitation is strongly recommended for normal operation. If these electrical characteristic conditions are exceeded during normal operation, ILI9341 will malfunction and cause poor reliability.

Item	Symbol	Unit	Value
Supply voltage	VCI	V	-0.3 ~ +4.6
Supply voltage (Logic)	VDDI	V	-0.3 ~ +4.6
Supply voltage (Digital)	VCORE	V	-0.3 ~ +2.0
Driver supply voltage	VGH-VGL	V	-0.3 ~ +32.0
Logic input voltage range	VIN	V	-0.3 ~ VDDI + 0.3
Logic output voltage range	VO	V	-0.3 ~ VDDI + 0.3
Operating temperature	Topr	°C	-40 ~ +85
Storage temperature	Tstg	°C	-55 ~ +110

*Note: If the absolute maximum rating of even is one of the above parameters is exceeded even momentarily, the quality of the product may be degraded. Absolute maximum ratings, therefore, specify the values exceeding which the product may be physically damaged. Be sure to use the product within the range of the absolute maximum ratings.*

### 5. Electrical Characteristics

Item	Symbol	Unit	Condition	Min.	Typ.	Max.	Note
Power and Operation Voltage							
Analog Operating Voltage	VCI	V	Operating voltage	2.5	2.8	3.3	Note2
Logic Operating Voltage	VDDI	V	I/O supply voltage	1.65	2.8	3.3	Note2
Digital Operating voltage	VCORE	V	Digital supply voltage	-	1.5	-	Note2
Gate Driver High Voltage	VGH	V	-	10.0	-	16.0	Note3
Gate Driver Low Voltage	VGL	V	-	-10.0	-	-5.0	Note3
Driver Supply Voltage	-	V	VGH-VGL	15	-	28	Note3
Current consumption during standby mode	I <sub>ST</sub>	µA	VCI=2.8V , Ta=25 °C	-	-	100	-
Input and Output							
Logic High Level Input Voltage	VIH	V	-	0.7*VDDI	-	VDDI	Note1,2,3
Logic Low Level Input Voltage	VIL	V	-	VSS	-	0.3*VDDI	Note1,2,3
Logic High Level Output Voltage	VOH	V	IOL=-1.0mA	0.8*VDDI	-	VDDI	Note1,2,3
Logic Low Level Output Voltage	VOL	V	IOL=1.0mA	VSS	-	0.2*VDDI	Note1,2,3
Logic High Level Input Current	IIH	µA	-	-	-	1	Note1,2,3
Logic Low Level input Current	IIL	µA	-	-1	-	-	Note1,2,3
Logic Input Leakage Current	ILEA	µA	VIN=VDDI or VSS	-0.1	-	+0.1	Note1,2,3

VCOM Operation							
VCOM High Voltage	VCOMH	V	Ccom=12nF	2.5	-	5.0	Note3
VCOM Low Voltage	VCOML	V	Ccom=12nF	-2.5	-	0.0	Note3
VCOM Amplitude Voltage	VCOMA	V	VCOMH-VCOML	4.0	-	5.5	Note3
Source Driver							
Source Output Range	Vsout	V	-	0.1	-	DDVDH-0.1	Note4
Gamma Reference Voltage	GVDD	V	-	3.0	-	5.0	Note3
Output Deviation Voltage (Source Output channel)	Vdev	mV	Sout>=4.2V	-	-	20	Note4
			Sout<=0.8V	-	-	15	-
Output Offset Voltage	VOFSET	mV	-	-	-	35	Note7
Booster Operation							
1 <sup>st</sup> Booster (VClx2) Voltage	DDVDH	V	-	4.95 (Note 5)	-	5.8 (Note 6)	Note3
1 <sup>st</sup> Booster (VClx2) Drop Voltage	VClx2 drop	%	loading=1mA	-	-	5	Note3
Liner Range	Vliner	V	-	0.2	-	DDVDH-0.2	

Note 1: VDDI=1.65 to 3.3V, VCI=2.5 to 3.3V, AGND=VSS=0V, Ta=-30 to 70 (to +85 no damage) °C.

Note2: Please supply digital VDDI voltage equal or less than analog VCI voltage.

Note3: CSX, RDX, WRX, D[17:0], D/CX, RESX, TE, DOTCLK, VSYNC, HSYNC, DE, SDA, SCL, IM3, IM2, IM1, IM0, and Test pins.

Note4: When the measurements are performed with LCD module. Measurement Points are like Note3.

Note5: VCI=2.6V

Note6: VCI=3.3V

Note7: The Max. Value is between with Note 4 measure point and Gamma setting value



## 6. Timing Characteristics.

### 6.1 Reset Timing Characteristics.

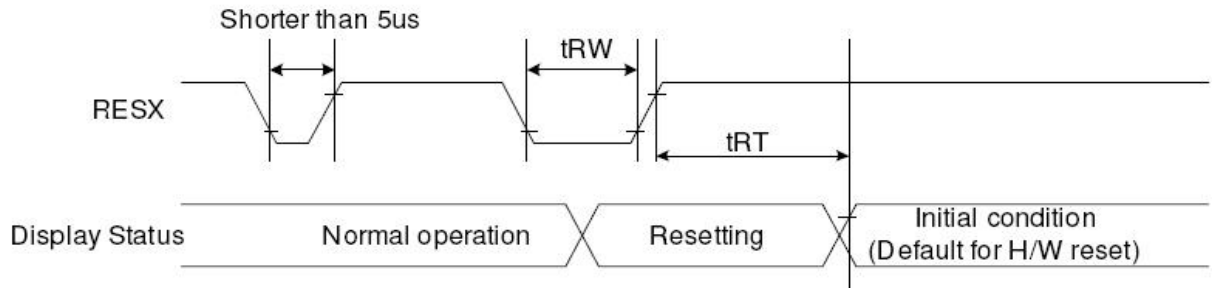

Signal	Symbol	Parameter	Min	Max	Unit
RESX	tRW	Reset pulse duration	10		uS
	tRT	Reset cancel		5 (note 1,5)	mS
				120 (note 1,6,7)	mS

Note 1: The reset cancel includes also required time for loading ID bytes, VCOM setting and other settings from NV memory to registers. This loading is done every time when there is HW reset cancel time (tRT) within 5 ms after a rising edge of RESX.

Note 2: Spike due to an electrostatic discharge on RESX line does not cause irregular system reset according to the table below: -

RESX Pulse	Action
Shorter than 5us	Reset Rejected
Longer than 10us	Reset
Between 5us and 10us	Reset starts

Note 3: During the Resetting period, the display will be blanked (The display is entering blanking sequence, which maximum time is 120 ms, when Reset Starts in Sleep Out –mode. The display remains the blank state in Sleep In -mode.) And then return to Default condition for Hardware Reset.

Note 4: Spike Rejection also applies during a valid reset pulse as shown below:

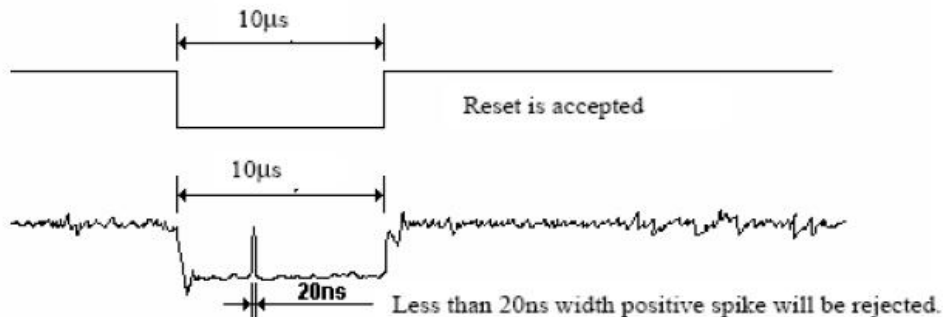

Note 5: When Reset applied during Sleep In Mode.

Note 6: When Reset applied during Sleep Out Mode.

Note 7: It is necessary to wait 5msec after releasing RESX before sending commands. Also Sleep Out command cannot be sent for 120msec.



6.2. i80-System Interface Timing Characteristics.

Display Parallel 18/16/9/8-bit Interface Timing Characteristics(8080- II system)

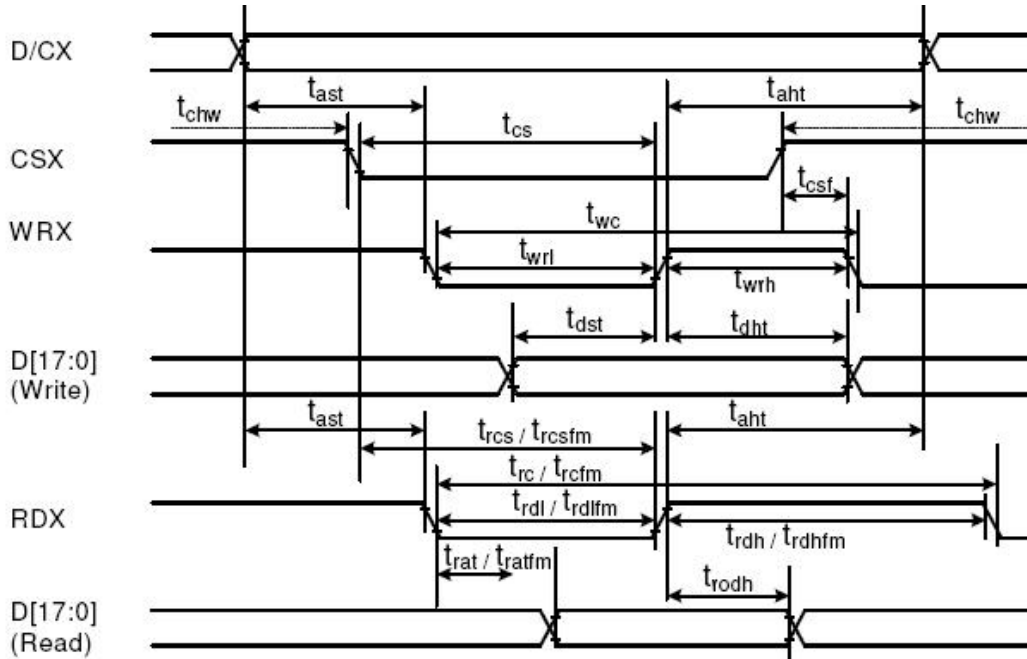

Signal	Symbol	Parameter	min	max	Unit	Description
DCX	tast	Address setup time	0	-	ns	
	taht	Address hold time (Write/Read)	0	-	ns	
CSX	tchw	CSX "H" pulse width	0	-	ns	
	tcs	Chip Select setup time (Write)	15	-	ns	
	trcs	Chip Select setup time (Read ID)	45	-	ns	
	trcsfm	Chip Select setup time (Read FM)	355	-	ns	
	tcsf	Chip Select Wait time (Write/Read)	10	-	ns	
WRX	twc	Write cycle	66	-	ns	
	twrh	Write Control pulse H duration	15	-	ns	
	twrl	Write Control pulse L duration	15	-	ns	
RDX (FM)	trcfm	Read Cycle (FM)	450	-	ns	
	trdhfm	Read Control H duration (FM)	90	-	ns	
	trdlfm	Read Control L duration (FM)	355	-	ns	
RDX (ID)	trc	Read cycle (ID)	160	-	ns	
	trdh	Read Control pulse H duration	90	-	ns	
	trdl	Read Control pulse L duration	45	-	ns	
D[17:0], D[17:10]&D[8:1], D[17:10], D[17:9]	tdst	Write data setup time	10	-	ns	For maximum CL=30pF For minimum CL=8pF
	tdht	Write data hold time	10	-	ns	
	trat	Read access time	-	40	ns	
	tratfm	Read access time	-	340	ns	
	trod	Read output disable time	20	80	ns	

Note: Ta = -30 to 70 °C, VDDI=1.65V to 3.3V, VCI=2.5V to 3.3V, VSS=0V.

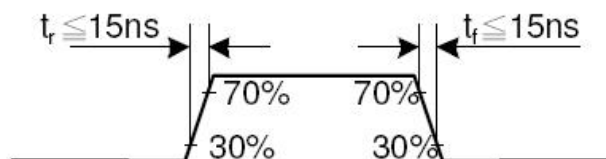

### 7. Backlight Characteristics.

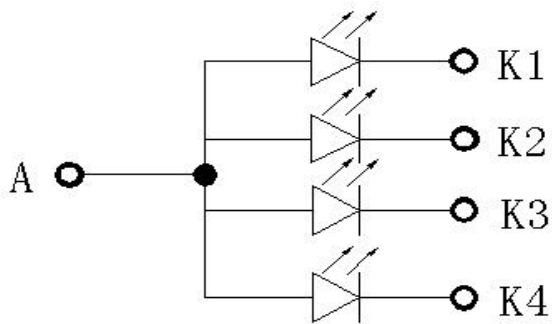

Item	Symbol	MIN	TYP	MAX	UNIT	Test Condition	Note
Supply Voltage	<b>Vf</b>	<b>3.0</b>	<b>3.2</b>	<b>3.4</b>	<b>V</b>	<b>If=60 mA</b>	-
Supply Current	<b>If</b>	-	<b>60</b>	-	<b>mA</b>	-	-
Reverse Voltage	<b>Vr</b>	-	-	<b>5</b>	<b>V</b>	<b>10uA</b>	
Power dissipation	<b>Pd</b>	-	<b>192</b>	-	<b>mW</b>	-	
Luminous Intensity for LCM		-	<b>200</b>	-	<b>Cd/m<sup>2</sup></b>	<b>If=60 mA</b>	
Uniformity for LCM	-	<b>80</b>	-	-	<b>%</b>	<b>If=60 mA</b>	
Life Time	-	<b>50000</b>	-	-	<b>Hr</b>	<b>If=60 mA</b>	-
Backlight Color	<b>White</b>						

## 8.Optical Characteristics

Item	Symbol	Condition	Min.	Typ.	Max.	Unit	Note	
Transmittance (without Polarizer)	T(%)	—	—	16.1	—	—		
Contrast Ratio	CR	$\theta=0$	400	500	—	—	(1)(2)	
Response time	Rising	$T_R$	Normal viewing angle	—	4	8	msec	(1)(3)
	Falling	$T_F$		—	12	24		
Color gamut	S(%)			60		%		
Color chromaticity (CIE1931)	White	$W_x$		0.298	0.318	0.338	(1)(4) CF glass (C-light)	
		$W_y$		0.317	0.337	0.357		
	Red	$R_x$		0.606	0.626	0.646		
		$R_y$		0.314	0.334	0.354		
	Green	$G_x$		0.299	0.319	0.339		
		$G_y$		0.537	0.557	0.577		
Blue	$B_x$		0.122	0.142	0.162			
	$B_y$		0.102	0.122	0.142			
Viewing angle	Hor.	$\theta_L$	CR>10	35	45	—		
		$\theta_R$		35	45	—		
	Ver.	$\theta_U$		35	45	—		
		$\theta_D$		10	20	—		
Optima View Direction	12 O'clock						(5)	

### Measuring Condition

- Measuring surrounding : dark room
- Ambient temperature : 25±2°C
- 15min. warm-up time.

### Measuring Equipment

- FPM520 of Westar Display technologies, INC., which utilized SR-3 for Chromaticity and BM-5A for other optical characteristics.

**Note (1)** Definition of Viewing Angle :

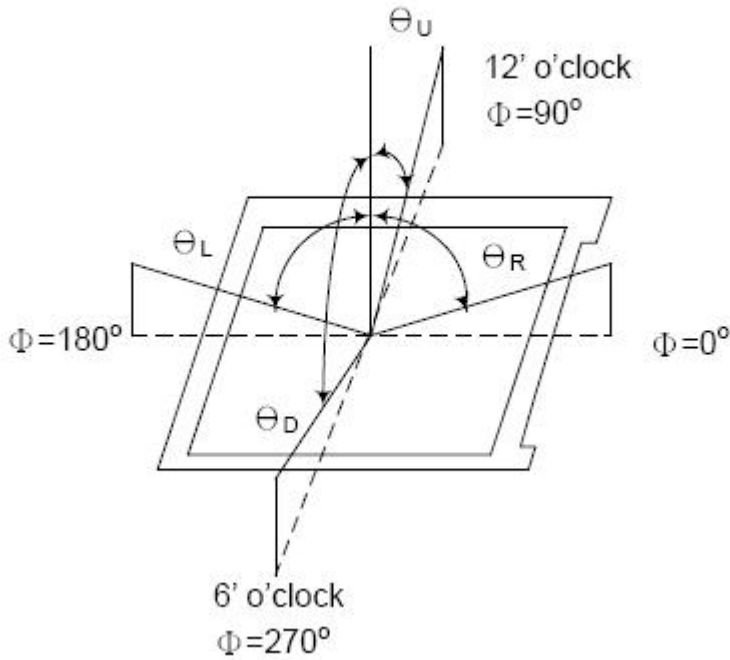

**Note (2)** Definition of Contrast Ratio(CR) :  
measured at the center point of panel

$$CR = \frac{\text{Luminance with all pixels white}}{\text{Luminance with all pixels black}}$$

**Note (3)** Definition of Response Time : Sum of  $T_R$  and  $T_F$

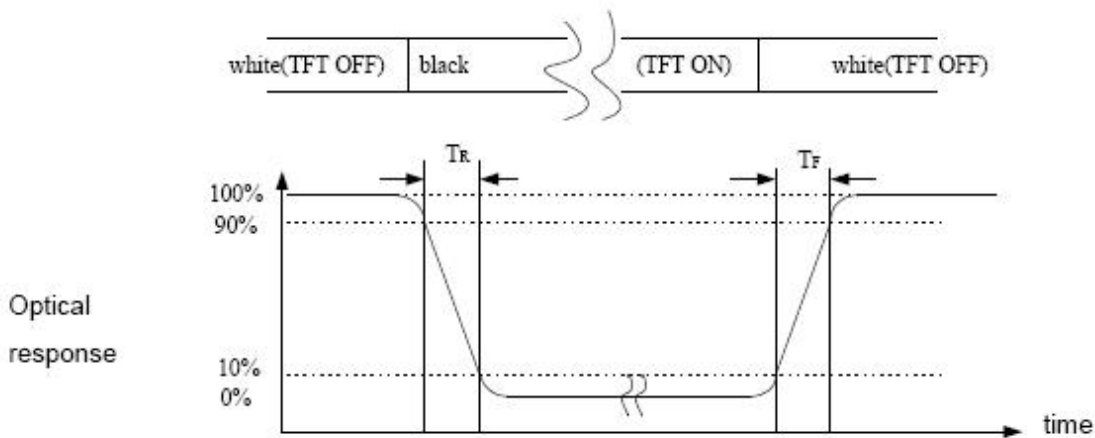

**Note (4)** Definition of optical measurement setup

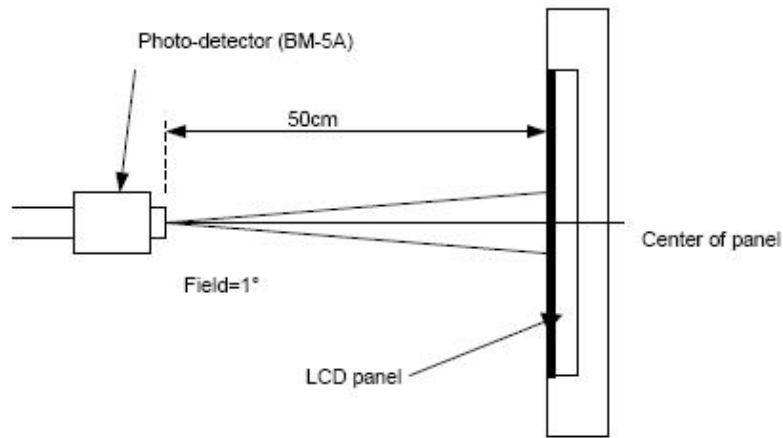

**Note (5)** Rubbing Direction (The different Rubbing Direction will cause the different view direction).

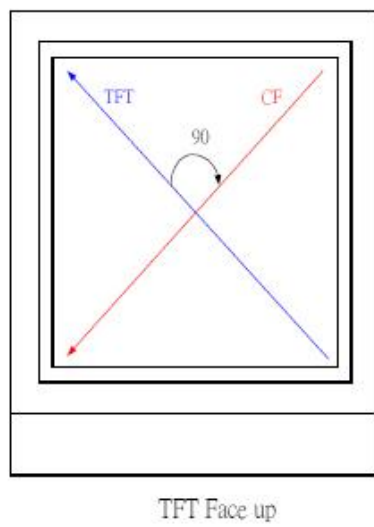

### 9. Reliability Test Conditions And Methods

N O.	TEST ITEMS	TEST CONDITION	INSPECTION AFTER TEST
①	High Temperature Storage	80°C ± 2°C × 200Hours	Inspection after 2~4hours storage at room temperature, the samples should be free from defects: 1,Air bubble in the LCD. 2,Sealleak. 3,Non-display. 4,Missing segments. 5,Glass crack. 6,Current IDD is twice higher than initial value. 7, The surface shall be free from damage. 8, The electric Characteristics requirements shall be satisfied.
②	Low Temperature Storage	- 30°C ± 2°C × 200Hours	
③	High Temperature Operating	70°C ± 2°C × 120Hours	
④	Low Temperature Operating	- 20°C ± 2°C / 120Hours	
⑤	Temperature Cycle(Storage)	- 30°C ± 2°C ↔ 25°C ↔ 80°C ± 2°C (30min) (5min) (30min) ← 1cycle → Total 10cycle	
⑥	Damp Proof Test	50°C ± 5°C × 90%RH × 120Hours	
⑦	Vibration Test	Frequency:10Hz~55Hz~10Hz Amplitude:1.5M X,Y,Z direction for total 3hours (Packing Condition)	
⑧	Drooping Test	Drop to the ground from 1M height one time every side of carton. (Packing Condition)	
⑨	ESD Test	Voltage: ± 8KV, R:330 Ω , C:150PF, Air Mode, 10times	

**REMARK:**

- 1,The Test samples should be applied to only one test item.
- 2,Sample side for each test item is 5~10pcs.
- 3,For Damp Proof Test,Pure water(Resistance>10MΩ) should be used.
- 4,In case of malfunction defect caused by ESD damage, if it would be recovered to normal state after resetting, it would be judge as a good part.
- 5,EL evaluation should be excepted from reliability test with humidity and temperature: Some defects such as black spot/blemish can happen by natural chemical reaction with humidity and Fluorescence EL has.
- 6, Failure Judgment Criterion: Basic Specification Electrical Characteristic, Mechanical Characteristic, Optical Characteristic.

## 10. Inspection Standard

This standard apply to TFT module specification.

### 1. Inspection condition:

Under daylight lamp 20~40W, product distance inspector's eye 30cm, incline degree 30°.

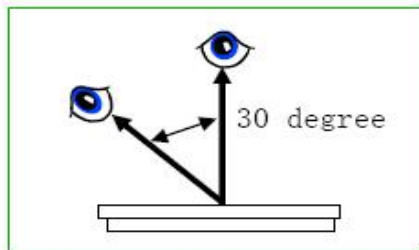

### 2. Inspection standard

NO.	Item	Inspection standard	Rate															
2.1	Dot	Case of Dot defect is below ① Bright Dot (whit spot) : "0" ② Dark Dot (black spot) : "0" (In case of Dark Dot on Main TFT LCD) - NG if there's full Dot defect. - Damaged less than the size of sub-pixel is not counted as defect - Dots darker than the size of sub-pixel are not defined as bright dot defect	minor															
		<table border="1"> <thead> <tr> <th>area size (mm)</th> <th>Acceptable number</th> </tr> </thead> <tbody> <tr> <td><math>\Phi \leq 0.10</math></td> <td>ignore</td> </tr> <tr> <td><math>0.10 &lt; \Phi \leq 0.15</math></td> <td>3</td> </tr> <tr> <td><math>0.15 &lt; \Phi \leq 0.20</math></td> <td>2</td> </tr> <tr> <td><math>0.25 &lt; \Phi \leq 0.25</math></td> <td>1</td> </tr> <tr> <td><math>0.25 &lt; \Phi</math></td> <td>0</td> </tr> </tbody> </table>		area size (mm)	Acceptable number	$\Phi \leq 0.10$	ignore	$0.10 < \Phi \leq 0.15$	3	$0.15 < \Phi \leq 0.20$	2	$0.25 < \Phi \leq 0.25$	1	$0.25 < \Phi$	0			
		area size (mm)		Acceptable number														
		$\Phi \leq 0.10$		ignore														
		$0.10 < \Phi \leq 0.15$		3														
		$0.15 < \Phi \leq 0.20$		2														
$0.25 < \Phi \leq 0.25$	1																	
$0.25 < \Phi$	0																	
2.2	line	<table border="1"> <thead> <tr> <th colspan="2">Size (mm)</th> <th>Acceptable number</th> </tr> </thead> <tbody> <tr> <td>ignore</td> <td><math>W \leq 0.03</math></td> <td>ignore</td> </tr> <tr> <td><math>L \leq 4.0</math></td> <td><math>0.03 &lt; W \leq 0.04</math></td> <td>2</td> </tr> <tr> <td><math>L \leq 4.0</math></td> <td><math>0.04 &lt; W \leq 0.05</math></td> <td>1</td> </tr> <tr> <td></td> <td><math>0.05 &lt; W</math></td> <td>Treat with dot non-conformance</td> </tr> </tbody> </table>	Size (mm)		Acceptable number	ignore	$W \leq 0.03$	ignore	$L \leq 4.0$	$0.03 < W \leq 0.04$	2	$L \leq 4.0$	$0.04 < W \leq 0.05$	1		$0.05 < W$	Treat with dot non-conformance	
		Size (mm)		Acceptable number														
		ignore	$W \leq 0.03$	ignore														
		$L \leq 4.0$	$0.03 < W \leq 0.04$	2														
		$L \leq 4.0$	$0.04 < W \leq 0.05$	1														
	$0.05 < W$	Treat with dot non-conformance																



## ■ PRECAUTIONS FOR USING LCD MODULES

### Handing Precautions

(1) The display panel is made of glass and polarizer. As glass is fragile. It tends to become or chipped during handling especially on the edges. Please avoid dropping or jarring. Do not subject it to a mechanical shock by dropping it or impact.

(2) If the display panel is damaged and the liquid crystal substance leaks out, be sure not to get any in your mouth. If the substance contacts your skin or clothes, wash it off using soap and water.

(3) Do not apply excessive force to the display surface or the adjoining areas since this may cause the color tone to vary. Do not touch the display with bare hands. This will stain the display area and degraded insulation between terminals (some cosmetics are determined to the polarizer).

(4) The polarizer covering the display surface of the LCD module is soft and easily scratched. Handle this polarizer carefully. Do not touch, push or rub the exposed polarizers with anything harder than an HB pencil lead (glass, tweezers, etc.). Do not put or attach anything on the display area to avoid leaving marks on. Condensation on the surface and contact with terminals due to cold will damage, stain or dirty the polarizer. After products are tested at low temperature they must be warmed up in a container before coming is contacting with room temperature air.

(5) If the display surface becomes contaminated, breathe on the surface and gently wipe it with a soft dry cloth. If it is heavily contaminated, moisten cloth with one of the following solvents

- Isopropyl alcohol
- Ethyl alcohol

Do not scrub hard to avoid damaging the display surface.

(6) Solvents other than those above-mentioned may damage the polarizer. Especially, do not use the following.

- Water
- Ketone
- Aromatic solvents

Wipe off saliva or water drops immediately, contact with water over a long period of time may cause deformation or color fading. Avoid contacting oil and fats.

(7) Exercise care to minimize corrosion of the electrode. Corrosion of the electrodes is accelerated by water droplets, moisture condensation or a current flow in a high-humidity environment.

(8) Install the LCD Module by using the mounting holes. When mounting the LCD module make sure it is free of twisting, warping and distortion. In particular, do not forcibly pull or bend the I/O cable or the backlight cable.

(9) Do not attempt to disassemble or process the LCD module.

(10) NC terminal should be open. Do not connect anything.

(11) If the logic circuit power is off, do not apply the input signals.

(12) Electro-Static Discharge Control, Since this module uses a CMOS LSI, the same careful attention should be paid to electrostatic discharge as for an ordinary CMOS IC. To prevent destruction of the elements by static electricity, be careful to maintain an optimum work environment.

- Before remove LCM from its packing case or incorporating it into a set, be sure the module and your body have the same electric potential. Be sure to ground the body when handling the LCD modules.

- Tools required for assembling, such as soldering irons, must be properly grounded. make certain the AC power source for the soldering iron does not leak. When using an electric screwdriver to attach LCM, the screwdriver should be of ground potentiality to minimize as much as possible any transmission of electromagnetic waves produced sparks coming from the commutator of the motor.

- To reduce the amount of static electricity generated, do not conduct assembling and other work under dry conditions. To reduce the generation of static electricity be careful that the air in the work is not too dried. A relative humidity of 50%-60% is recommended. As far as possible make the electric potential of your work clothes and that of the work bench the ground potential

- The LCD module is coated with a film to protect the display surface. Exercise care when peeling off this protective film since static electricity may be generated

(13) Since LCM has been assembled and adjusted with a high degree of precision, avoid applying excessive shocks to the module or making any alterations or modifications to it.

- Do not alter, modify or change the shape of the tab on the metal frame.
- Do not make extra holes on the printed circuit board, modify its shape or change the positions of components to be attached.
- Do not damage or modify the pattern writing on the printed circuit board.
- Absolutely do not modify the zebra rubber strip (conductive rubber) or heat seal connector.
- Except for soldering the interface, do not make any alterations or modifications with a soldering iron.
- Do not drop, bend or twist LCM.

**Handling precaution for LCM**

LCM is easy to be damaged.  
Please note below and be careful for handling!

**Correct handling:**



As above picture, please handle with anti-static gloves around LCM edges.

**Incorrect handling:**

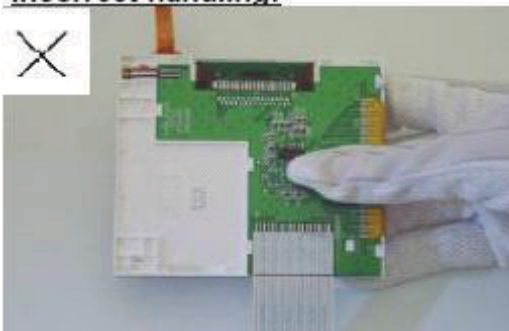

Please don't touch IC directly.

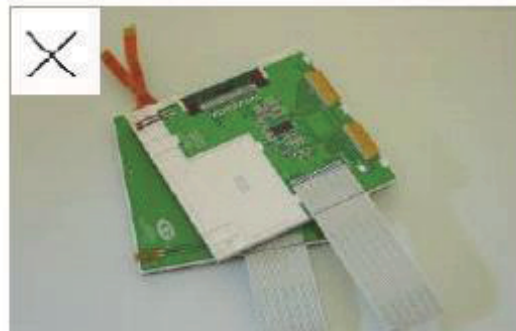

Please don't stack LCM.

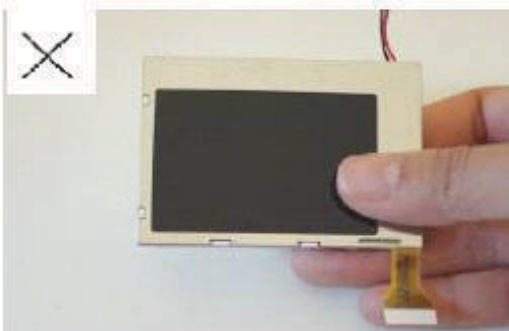

Please don't hold the surface of panel.

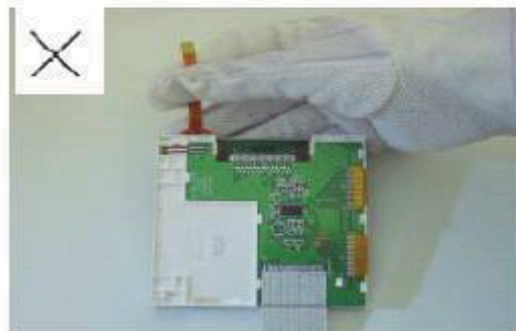

Please don't stretch interface of output, such as FPC cable.

**Handling precaution for LCD**

LCD is easy to be damaged.  
Please note below and be careful for handling!

**Correct handling:**

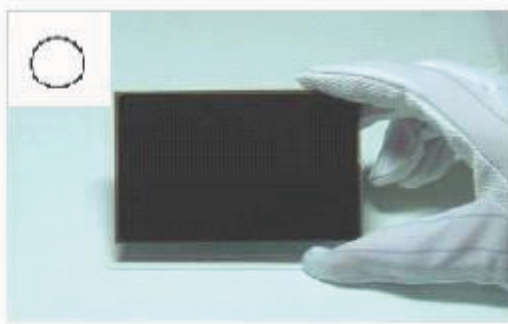

As above photo, please handle with anti-static gloves around LCD edges.

**Incorrect handling:**

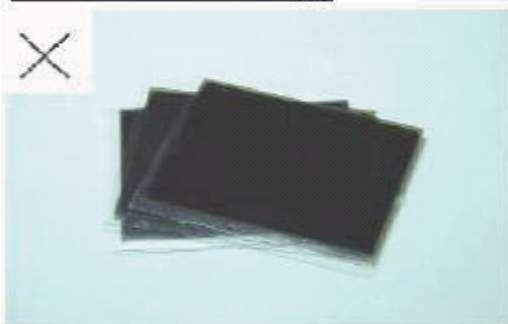

Please don't stack the LCDS.

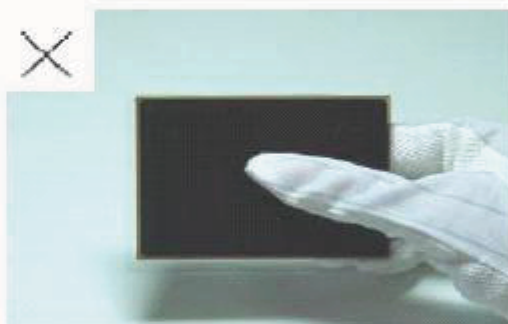

Please don't hold the surface of LCD.

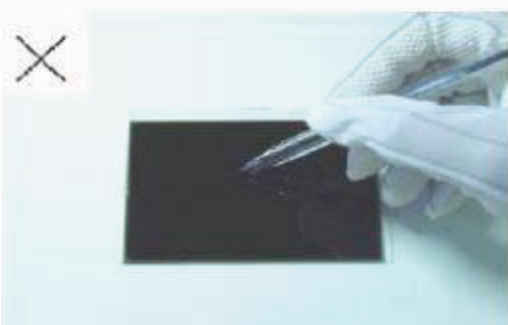

Please don't operate with sharp stick such as pens.

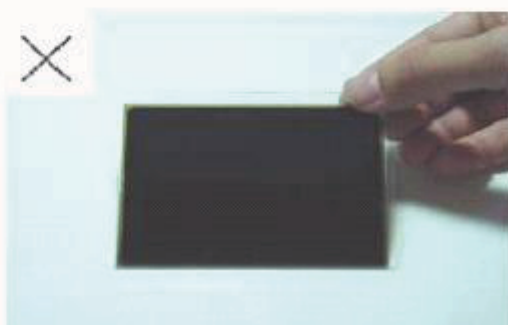

Please don't touch ITO glass without anti-static gloves.

**Storage Precautions**

When storing the LCD modules, the following precaution is necessary.

- (1) Store them in a sealed polyethylene bag. If properly sealed, there is no need for the dessicant.
- (2) Store them in a dark place. Do not expose to sunlight or fluorescent light, keep the temperature between 0°C and 35°C, and keep the relative humidity between 40%RH and 60%RH.
- (3) The polarizer surface should not come in contact with any other objects. (We advise you to store them in the anti-static electricity container in which they were shipped.

**Others**

Liquid crystals solidify under low temperature (below the storage temperature range) leading to defective orientation or the generation of air bubbles (black or white). Air bubbles may also be generated if the module is subject to a low temperature.

If the LCD modules have been operating for a long time showing the same display patterns, the display patterns may remain on the screen as ghost images and a slight contrast irregularity may also appear. A normal operating status can be regained by suspending use for some time. It should be noted that this phenomenon does not adversely affect performance reliability.

To minimize the performance degradation of the LCD modules resulting from destruction caused by static electricity etc., exercise care to avoid holding the following sections when handling the modules.

- Exposed area of the printed circuit board.
- Terminal electrode sections.

**USING LCD MODULES**

**Installing LCD Modules**

The hole in the printed circuit board is used to fix LCM as shown in the picture below. Attend to the following items when installing the LCM.

- (1) Cover the surface with a transparent protective plate to protect the polarizer and LC cell.

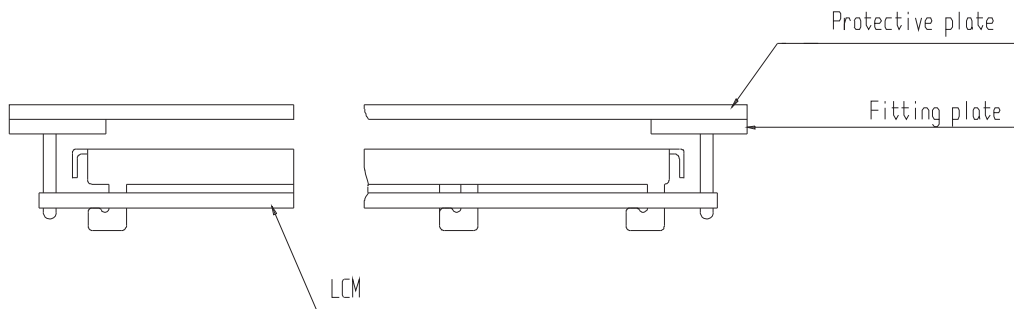

- (2) When assembling the LCM into other equipment, the spacer to the bit between the LCM and the fitting plate should have enough height to avoid causing stress to the module surface, refer to the individual specifications for measurements. The measurement tolerance should be  $\pm 0.1$ mm.

**Precaution for assemble the module with BTB connector:**

Please note the position of the male and female connector position, don't assemble or assemble like the method which the following picture shows

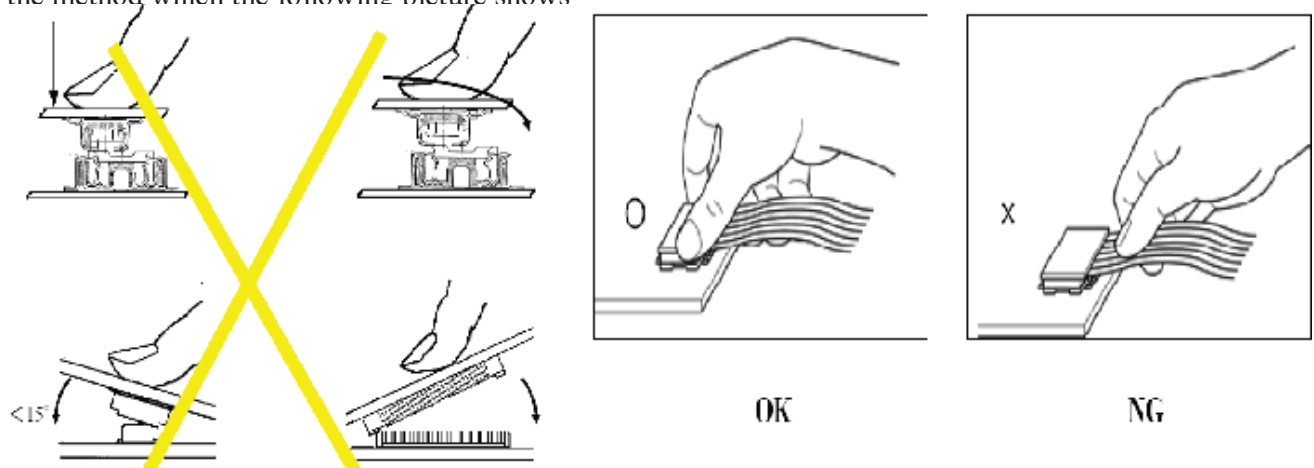



**Precaution for soldering to the LCM**

	Hand soldering	Machine drag soldering	Machine press soldering
No ROHS product	290°C ~350°C. Time : 3-5S.	330°C ~350°C. Speed : 4-8 mm/s.	300°C ~330°C. Time : 3-6S. Press: 0.8~1.2Mpa
ROHS product	340°C ~370°C. Time : 3-5S.	350°C ~370°C. Time : 4-8 mm/s.	330°C ~360°C. Time : 3-6S. Press: 0.8~1.2Mpa

(1) If soldering flux is used, be sure to remove any remaining flux after finishing to soldering operation. (This does not apply in the case of a non-halogen type of flux.) It is recommended that you protect the LCD surface with a cover during soldering to prevent any damage due to flux spatters.

(2) When soldering the electroluminescent panel and PC board, the panel and board should not be detached more than three times. This maximum number is determined by the temperature and time conditions mentioned above, though there may be some variance depending on the temperature of the soldering iron.

(3) When remove the electroluminescent panel from the PC board, be sure the solder has completely melted, the soldered pad on the PC board could be damaged.

**Precautions for Operation**

(1) Viewing angle varies with the change of liquid crystal driving voltage (VLCD). Adjust VLCD to show the best contrast.

(2) It is an indispensable condition to drive LCD's within the specified voltage limit since the higher voltage then the limit cause the shorter LCD life. An electrochemical reaction due to direct current causes LCD's undesirable deterioration, so that the use of direct current drive should be avoided.

(3) Response time will be extremely delayed at lower temperature than the operating temperature range and on the other hand at higher temperature LCD's show dark color in them. However those phenomena do not mean malfunction or out of order with LCD's, Which will come back in the specified operating temperature.

(4) If the display area is pushed hard during operation, the display will become abnormal. However, it will return to normal if it is turned off and then back on.

(5) A slight dew depositing on terminals is a cause for electro-chemical reaction resulting in terminal open circuit. Usage under the maximum operating temperature,50%RH or less is required.

(6) Input each signal after the positive/negative voltage becomes stable.

(7) Please keep the temperature within specified range for use and storage. Polarization degradation, bubble generation or polarizer peel-off may occur with high temperature and high humidity.

**Safety**

(1) It is recommended to crush damaged or unnecessary LCDs into pieces and wash them off with solvents such as acetone and ethanol, which should later be burned.

(2) If any liquid leaks out of a damaged glass cell and comes in contact with the hands, wash off thoroughly with soap and water.

**Safety**

- (1) It is recommended to crush damaged or unnecessary LCDs into pieces and wash them off with solvents such as acetone and ethanol, which should later be burned.
- (2) If any liquid leaks out of a damaged glass cell and comes in contact with the hands, wash off thoroughly with soap and water.

**Limited Warranty**

Unless agreed otherwise between Display Future Ltd and customer, Display Future will replace or repair any of its LCD modules which are found to be functionally defective when inspected in accordance with LCD acceptance standards (copies available upon request) for a period of one year from date of production. Cosmetic/visual defects must be returned within 90 days of the shipment. Confirmation of such date shall be based on data code on the product.

The warranty liability of Display Future limited to repair and/or replacement on the terms set forth above. Display Future will not be responsible for any subsequent or consequential events.

**Return LCM under warranty**

No warranty can be granted if the precautions stated above have been disregarded. The typical examples of violations are :

- Broken LCD glass.
- PCB eyelet is damaged or modified.
- PCB conductors damaged.
- Circuit modified in any way, including addition of components.
- PCB tampered with by grinding, engraving or painting varnish.
- Soldering to or modifying the bezel in any manner.

Module repairs will be invoiced to the customer upon mutual agreement. Modules must be returned with sufficient description of the failures or defects. Any connectors or cable installed by the customer must be removed completely without damaging the PCB eyelet, conductors and terminals.

**■ PRIOR CONSULT MATTER**

- 1.①For Display Future standard products, we keep the right to change material and processes for improving the product, without notice to our customers.  
②For OEM products, if any change is needed, which may affect the product property, we will consult with our customer in advance.
2. If you have special requirement about reliability condition, please let us know before you start the test on our samples.