



Display Future Ltd

www.displayfuture.com

LCD MODULE SPECIFICATION

Model: DF-TFC0430FB-F1

This module uses ROHS materials

For customer acceptance

Customer		date
Approved		
Comments		

The standard product specification may change without prior notice in order to improve performance or quality. Please contact Display Future Ltd for updated specification and product status before design for the standard product or release of the order.

Revision	1.0
Engineering	
Date	2018/01/4
Our Reference	

Revision record

VER NO.	VER DATE	CONTENTS	Note
1.0	2017-12-08	NEW ISSUE	

Table Of Contents

List	Description	Page No.
0	Cover	1
0	Revision Record	2
0	Table Of Contents	3
1	General Description	4
2	External Dimensions	5
3	Interface Description	6
4	Absolute Maximum Ratings	7
5	Electrical Characteristics	7
6	Timing Characteristics	8
7	Backlight Characteristics	14
8	Optical Characteristics	15
9	Reliability	18
10	Inspection Standard	19

1. General Description

1.1 Description

DF-TFC0430FB-F1 is a Transmissive type color active matrix liquid crystal display (LCD), which uses amorphous thin film transistor (TFT) as switching devices. This product is composed of a TFT LCD panel, driver IC, FPC ,backlight and CTP unit . The following table described the features of DF-TFC0430FB-F1 .

1.2 Application

PAD,PMP,MP4,DVB-S,GPS, Multimedia products,Portable Navigation and other electronic Products

1.3 Features:

Features	Description	UNITS
LCD type	4.3'TFT	--
Dot arrangement	480 (RGB) × 272	dots
Driver IC	HX8257	--
Color Depth	16M	
Interface	RGB 24bit Interface	
View Direction	6 O'clock	
Module size	115.50(W) × 77.20 (H) × 4.70(T)	mm
Active area	95.04(W) × 53.86 (H)	mm
Dot pitch	0.198 (W) × 0.198 (H)	mm
Back Light	7 White LED In Serial	--
With/Without TSP	With CTP	
Weight(g)	TBD	

2. External Dimensions

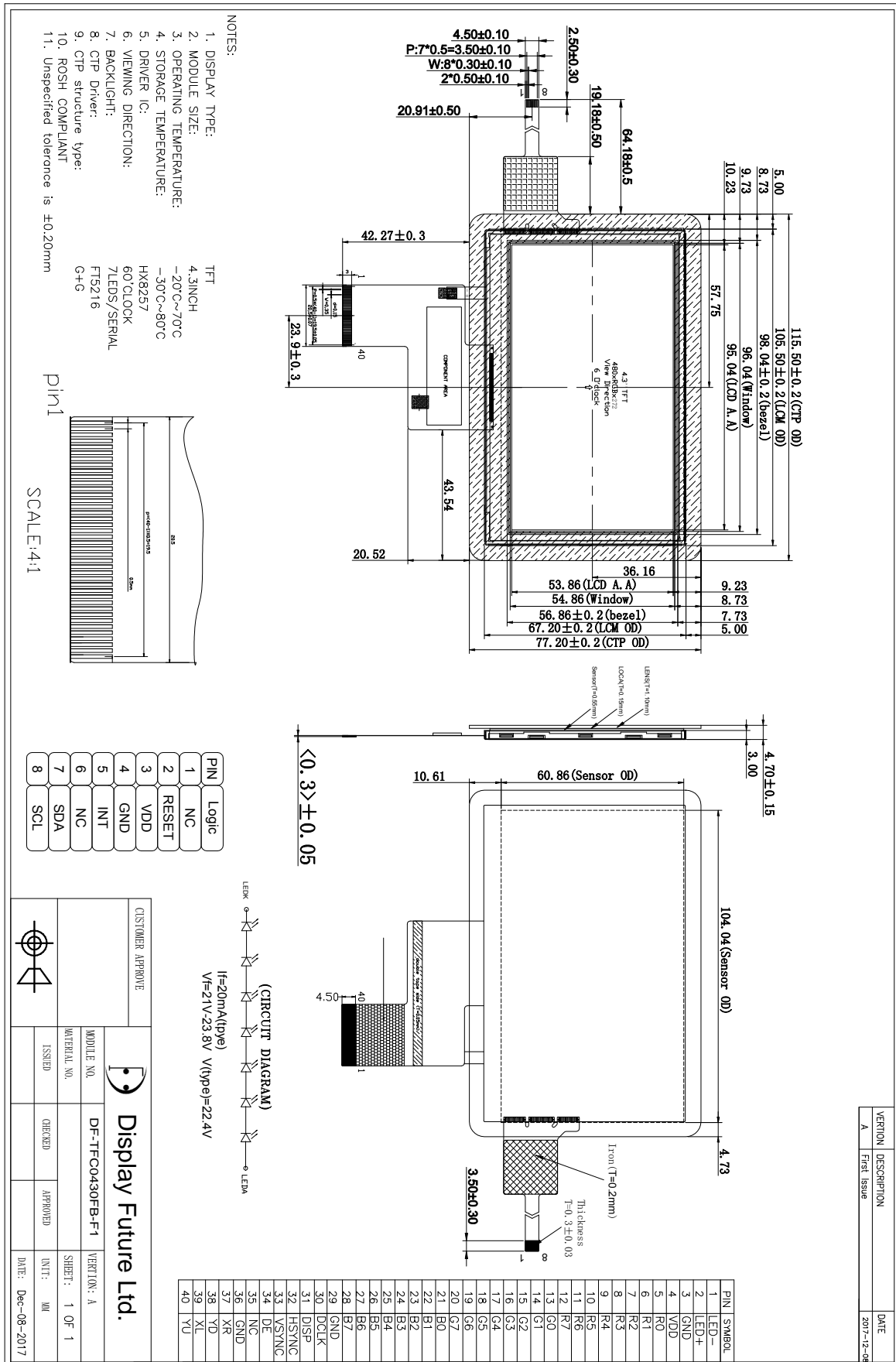

VERSION	DESCRIPTION	DATE
A	First Issue	2017-12-08

3. Interface Description

FPC Connector is used for the module electronics interface. The recommended model is FH19SC-40S-0.5SH manufactured by HIROSE.

Pin No.	Symbol	Functional	Remark
1	VLED-	Power for LED backlight cathode.	
2	VLED+	Power for LED backlight anode.	
3	GND	Power ground.	
4	VDD	Power voltage.	
5	R0	Red data(LSB).	
6	R1	Red data.	
7	R2	Red data.	
8	R3	Red data.	
9	R4	Red data.	
10	R5	Red data.	
11	R6	Red data.	
12	R7	Red data(MSB).	
13	G0	Green data(LSB).	
14	G1	Green data.	
15	G2	Green data.	
16	G3	Green data.	
17	G4	Green data.	
18	G5	Green data.	
19	G6	Green data.	
20	G7	Green data(MSB).	
21	B0	Blue data(LSB).	
22	B1	Blue data.	
23	B2	Blue data.	
24	B3	Blue data.	
25	B4	Blue data.	
26	B5	Blue data.	
27	B6	Blue data.	
28	B7	Blue data(MSB).	
29	GND	Power Ground.	
30	CLK	Pixel clock.	
31	DISP	Display on/off.	NOTE1
32	HSYNC	No Connector.	
33	VSYNC	No Connector.	
34	DE	Data Enable.	NOTE2
35	NC	No Connector.	
36	GND	Power Ground.	
37	XR	Touch panel pin for XR.	
38	YD	Touch panel pin for YD.	
39	XL	Touch panel pin for XL.	
40	YU	Touch panel pin for YU.	

Note1: During set to DISP=" H ", input data are valid. During set to DISP=" L ", input data are invalid and white display data is written to data register automatically.

Note2: DE=" H ": data can be access, DE=" L ": data cannot be access

FPC Connector is used for the cap. Touch panel electronics interface. The recommended model is FH19SC-8S-0.5SH manufactured by HIROSE.

Pin No.	Symbol	Functional	Remark
1	NC	No connection	
2	RESET	Reset pin for system.	
3	VDD	2.8~3.3V Power supply.	
4	GND	Ground .	
5	INT	Interrupt pin.	
6	NC	No connection	
7	SDA	Serial data PIN for IIC interface	
8	SCL	Serial clock PIN for IIC interface	

4. Absolute Maximum Ratings

Item	Symbol	Values		Unit	Condition
		Min.	Max.		
Power Voltage	VDD	0.3	5.0	V	
Logic Input Signal	VIN	-0.3	VDD+0.3	V	
Logic Output Signal	VOUT	-0.3	VDD+0.3	V	

Note: Device is subject to be damaged permanently if stresses beyond those absolute maximum ratings listed above

5. Electrical Characteristics

5.1 Operating conditions:

Item	Symbol	Values			Unit	Remark
		Min.	Typ.	Max.		
Power Supply	VDD	3.0	3.3	3.6	V	
Operating Current	IDD	-	15	-	mA	Black pattern
Frame frequency	Frame	-	60	90	Hz	
Dot Data Clock	DCLK	-	9.0	15	MHz	
Power Consumption	PLCD	-	49.5	-	mW	Black pattern

5.2 DC CHARATERISTICS

Parameter	Symbol	Rating			Unit	Condition
		Min.	Typ.	Max.		
Low level input voltage	V_{IL}	0	-	$0.3 \cdot V_{DD}$	V	
High level input voltage	V_{IH}	$0.7 \cdot V_{DD}$	-	VDD	V	

6.Timing Characteristics.

6.1 Touch panel IIC timing.

VCC=3.3V,pull up resistance 2K.

Parameter	Unit	Min	Max
SCL frequency	KHz	0	400
Bus free time between a STOP and START condition	us	4.7	\
Hold time (repeated) START condition	us	4.0	\
Data setup time	ns	250	\
Setup time for a repeated START condition	us	4.7	\
Setup Time for STOP condition	us	4.0	\

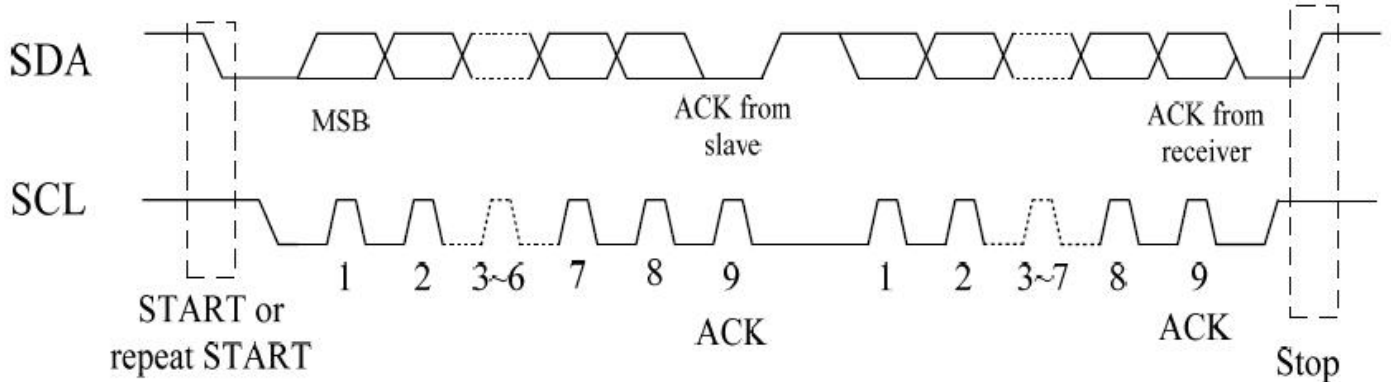

I2C Serial Data Transfer Format

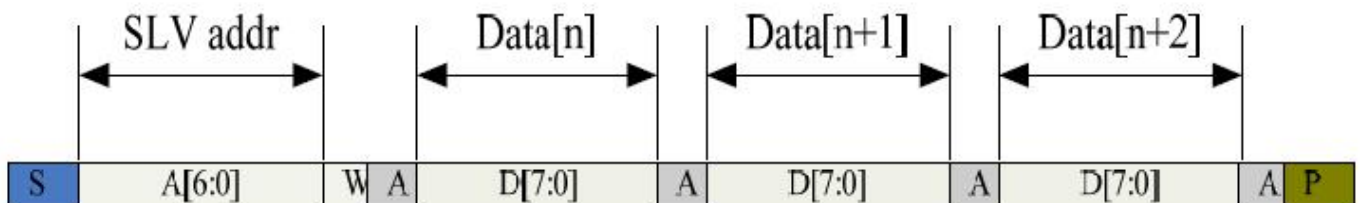

I2C master write, slave read

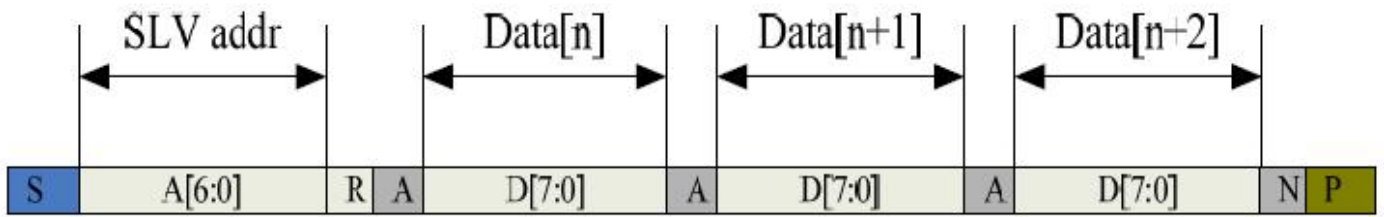

I2C master read, slave write

Mnemonics	Description
S	I2C Start or I2C Restart
A[6:0]	Slave address A[6:0]: address bits are identical to those of I2CADDR [7:1] register.
R/ W	'1' for read, '0' for write
A(N)	ACK(NACK)
P	STOP: the indication of the end of a packet (if this bit is missing, S will indicate the end of the current packet and the beginning of the next packet)

6.2. RGB Interface AC Timing Characteristics.

Parameter	Symbol	Spec.			Unit
		Min	Typ	Max	
DISP setup time	t_{diss}	10			ns
DISP hold time	t_{dish}	10			ns
Clock period	$PW_{CLK}^{(2)}$	66.7	-	-	ns
Clock pulse high period	$PWH^{(2)}$	26.7	-	-	ns
Clock pulse low period	$PWL^{(2)}$	26.7	-	-	ns
Hsync setup time	t_{hs}	10	-	-	n
Hsync hold time	t_{hh}	10	-	-	
Data setup time	t_{ds}	10	-		ns
Data hold time	t_{dh}	10	-		ns
DE setup time	t_{des}	10	-		ns
DE hold time	t_{deh}	10			ns
Vsync setup time	t_{vhs}	10		-	ns
Vsync hold time	t_{vhh}	10		-	ns

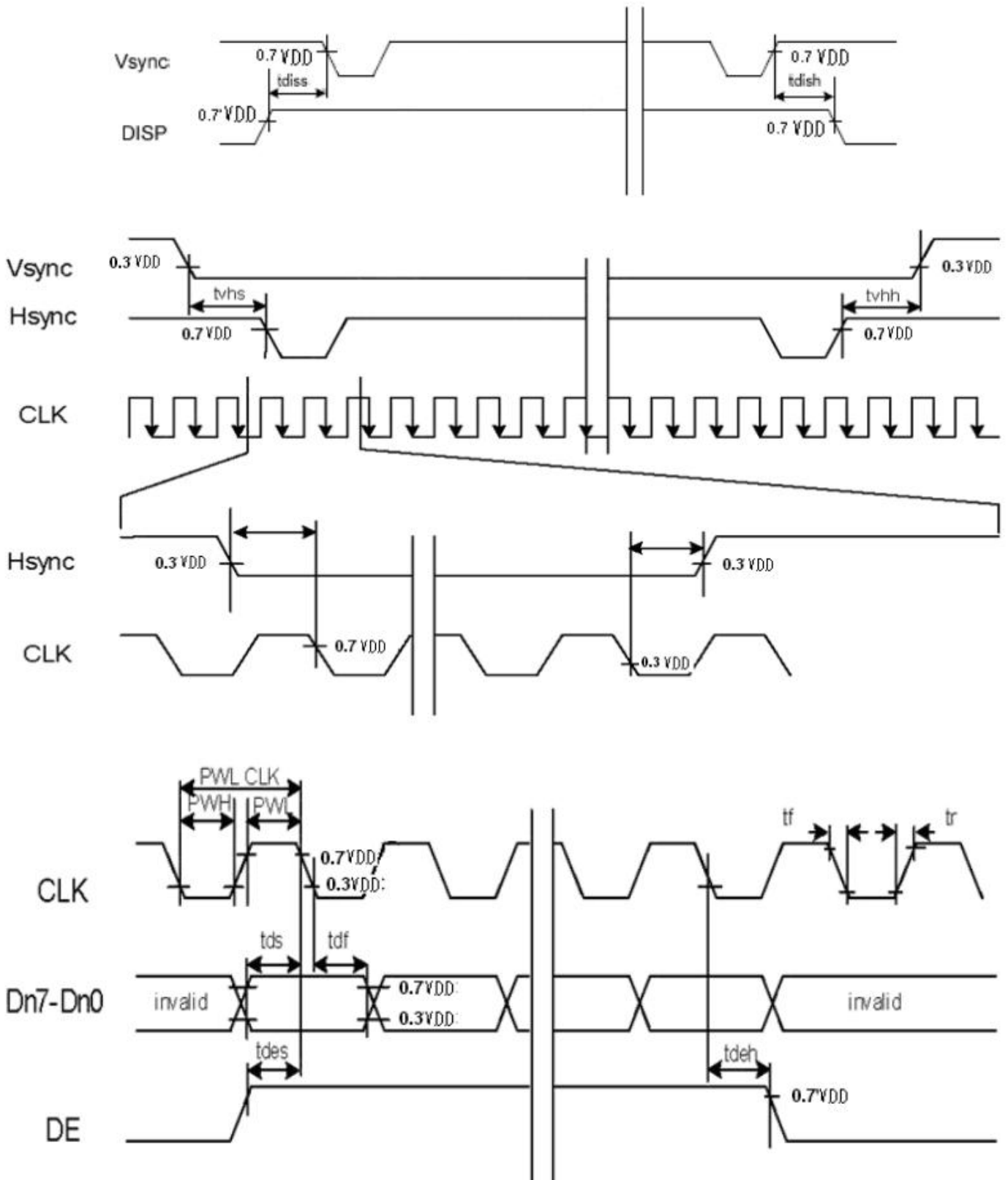

6.3. RGB Interface DC Timing Characteristics.

Signal	Item	Symbol	Min	Typ	Max	Unit	Note
Dclk	Frequency	DCLK	-	9.0	12	MHZ	
Hsync	Period	TH	-	525	-	DCLK	(1)
	Pulse Width	Thp	2	41	-	DCLK	(2)
	Back-Porch	Thb	2	-	-	DCLK	(2)
	Display Period	Thd	-	480	-	DCLK	
	Front-Porch	Thf	2	-	-	DCLK	(2)
Vsync	Period	Tv	-	286	-	TH	
	Pulse Width	Tvp	1	10	-	TH	
	Back-Porch	Tvb	1	2	-	TH	
	Display Period	Tvd	-	27		TH	
	Front-Porch	Tvf	1		-	TH	

Note1: Thd=480 DCLK, Thf=2 DCLK, Thp= 41
525 DCLK= 480 + 2 + 41 + 2 (DCLK)

hb=2 DCLK

Note2: Thf+ Thp+ Thb >44

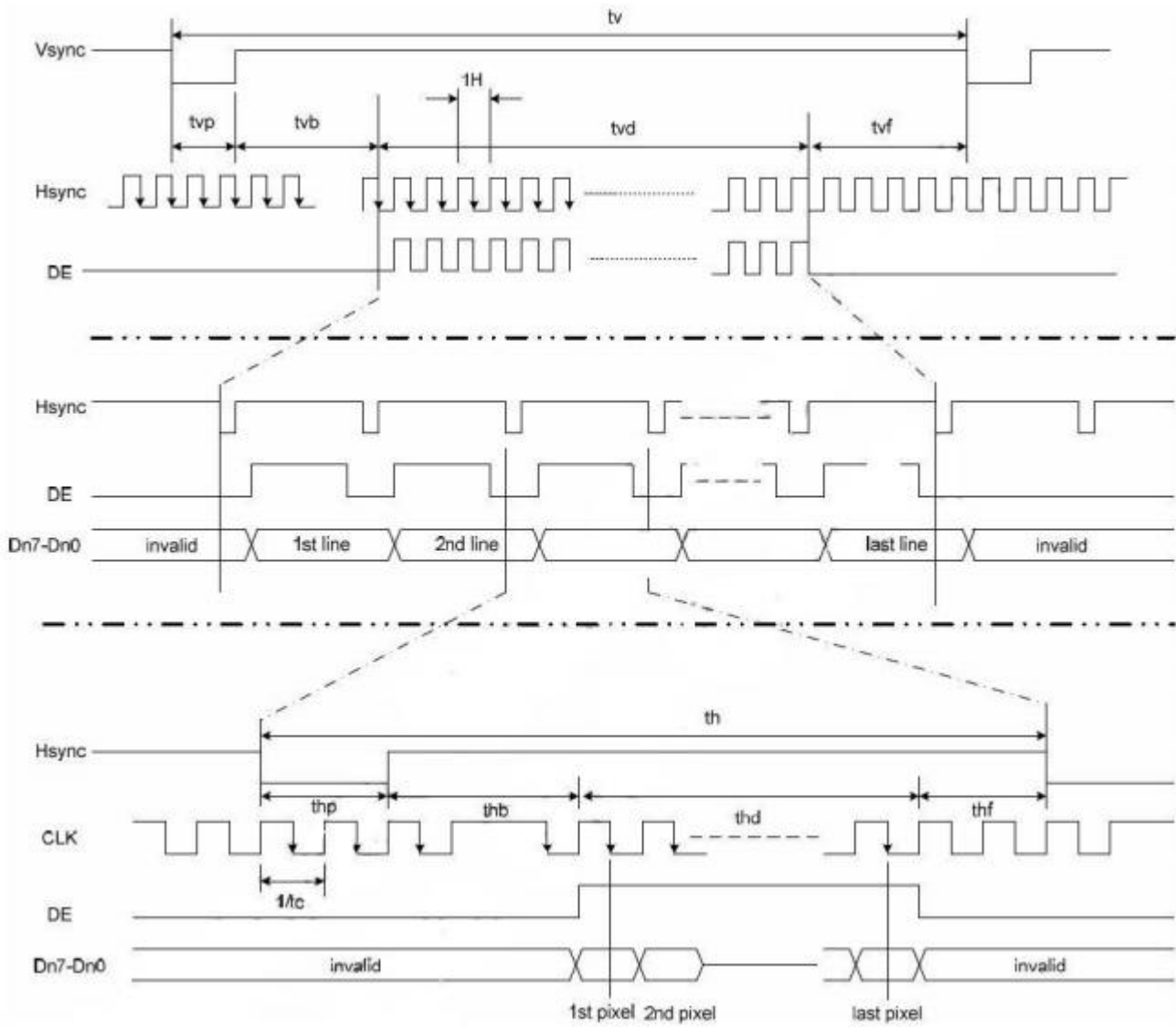

6.4 Power sequence

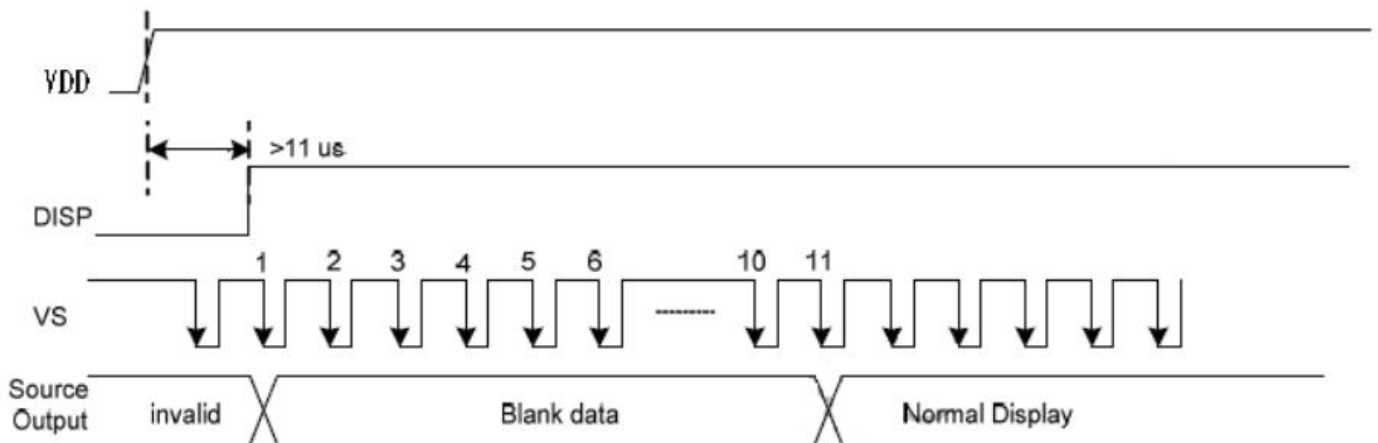

Power On Sequence

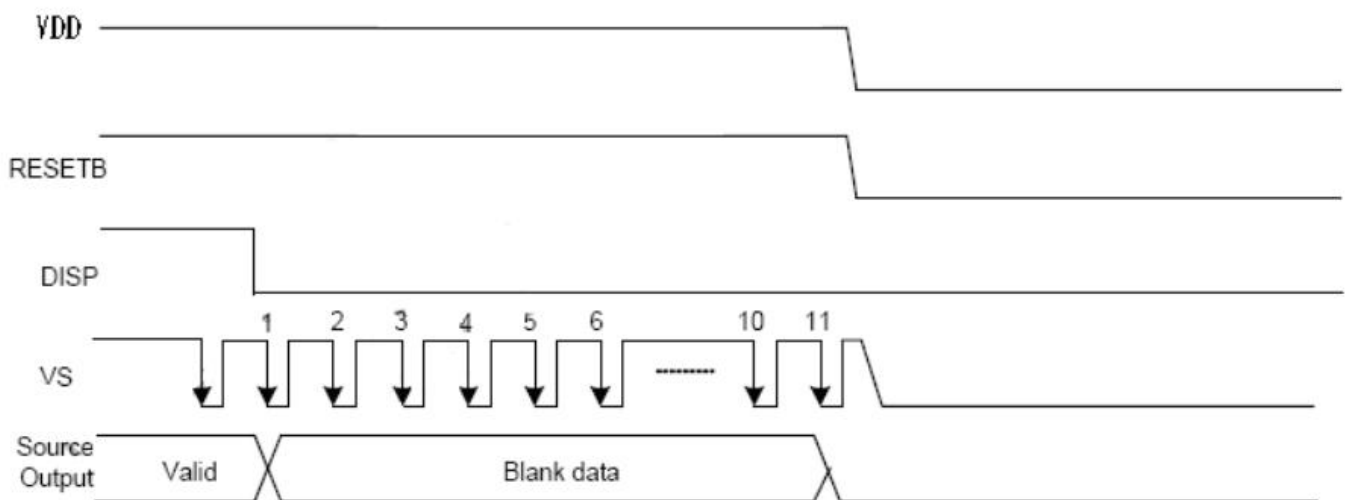

Power Off Sequence

7. Backlight Characteristics.

(CIRCUIT DIAGRAM)

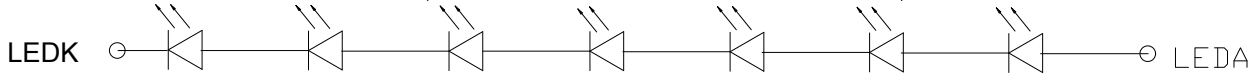

Item	Sy mb ol	MIN	TYP	MAX	UNIT	Test Condition	Note
Supply Voltage	Vf	20.0	22.4	24.0	V	If=20 mA	-
Supply Current	If	-	20	-	mA	-	-
Reverse Voltage	Vr	-	-	5	V	10uA	
Power dissipation	Pd	-	448	-	mW	-	
Luminous Intensity for LCM		220	250	-	Cd/m2	If=20 mA	
Uniformity for LCM	-	80	-	-	%	If=20 mA	
Life Time	-	50000	-	-	Hr	If=20 mA	-
Backlight Color	White						

8.Optical Characteristics

Item	Symbol	Condition	Min	Typ	Max	Unit	Note	
Response time	TR	$\Theta=0$	-	15	-	ms	(3)(5)	
	TF		-	15	-	ms		
Contrast ratio	CR	At optimized viewing angle	450	550	-	-	(4)	
Color Chromaticity	White	Wx	$\Theta=0$	0.26	0.31	0.36	-	(2)(6)
		Wy		0.28	0.33	0.38		
Viewing Angle	Hor.	Θ_R	$CR \geq 10$	60	70	-	-	(1)
		Θ_L		60	70	-		
	Ver.	ϕ_H		45	55	-		
		ϕ_L		60	70	-		
Uniformity			75	80		%	(8)	

Note 1: Definition of viewing angle range

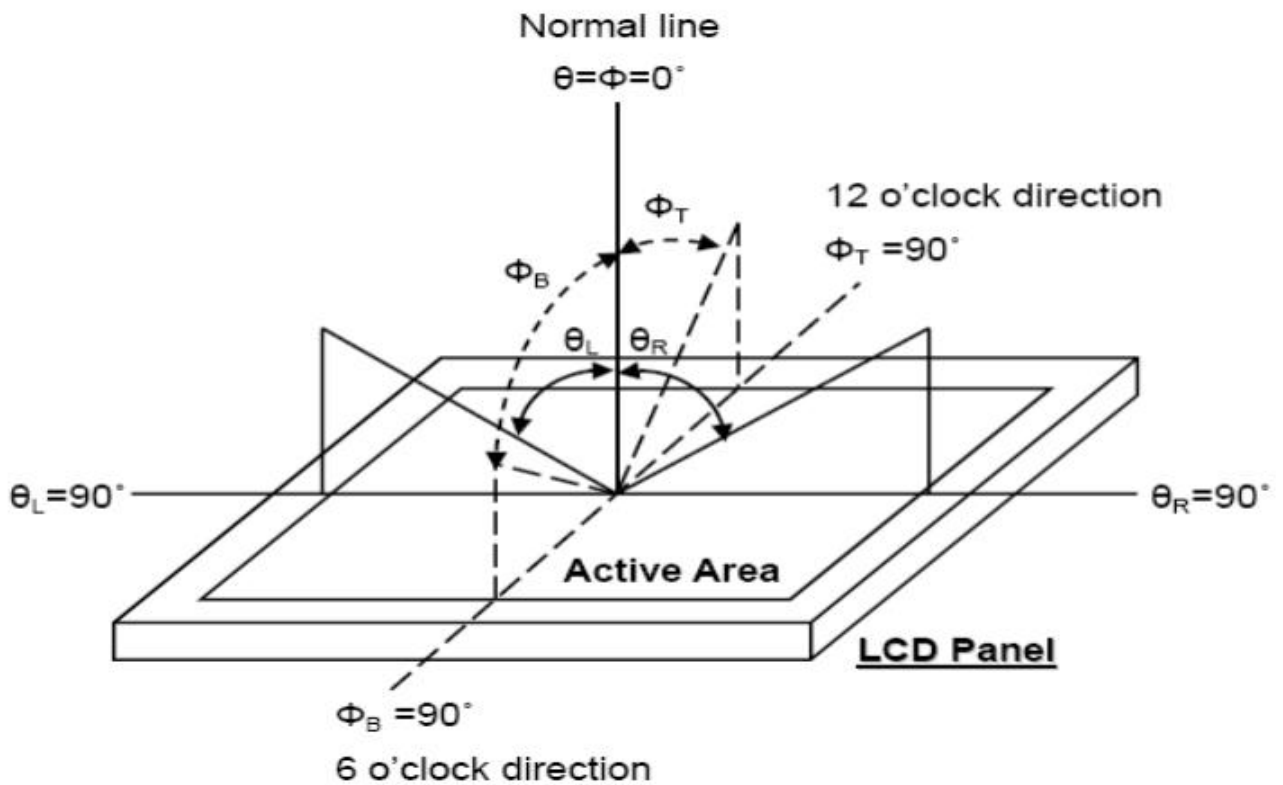

Note 2: Test equipment setup:

After stabilizing and leaving the panel alone at a driven temperature for 10 minutes, the measurement should be executed. Measurement should be executed in a stable, windless, and dark room. Optical specifications are measured by Topcon BM-7 luminance meter 1.0° field of view at a distance of 50cm and normal direction.

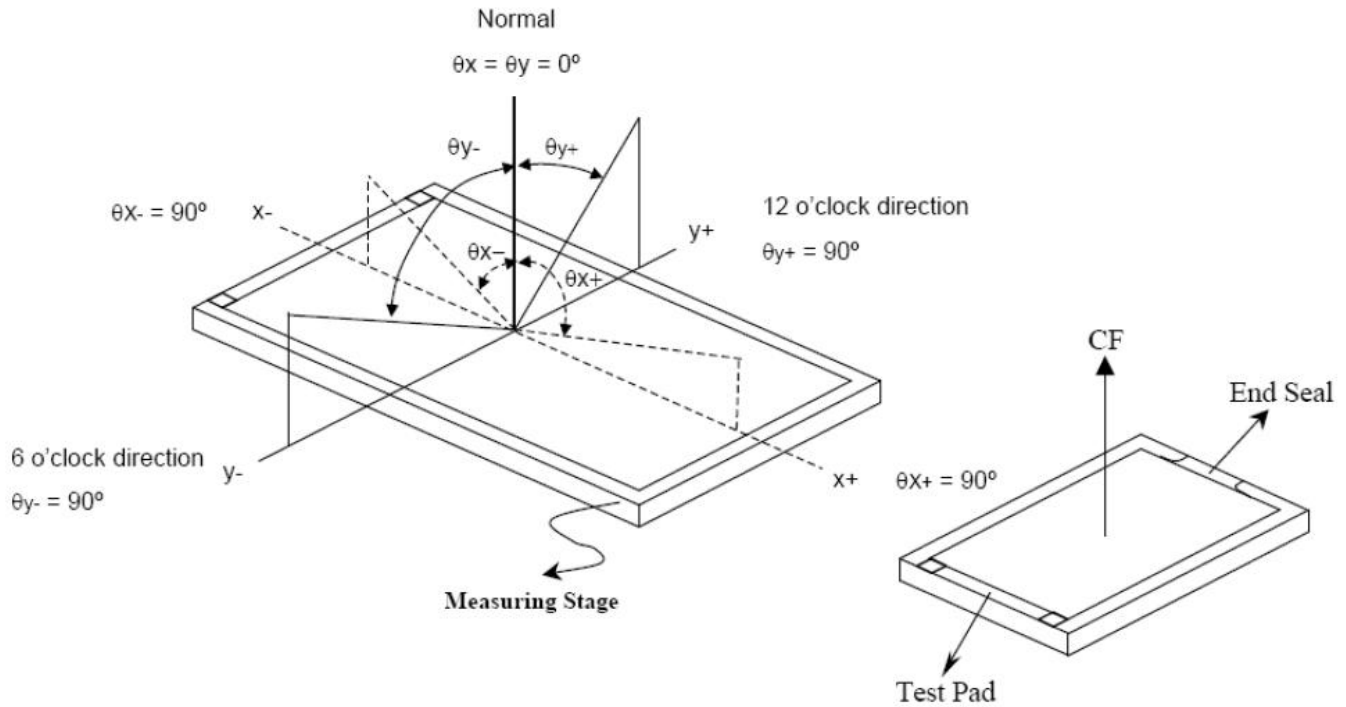

Note 3: Definition of Response time:

The response time is defined as the LCD optical switching time interval between "White" state and "Black" state. Rise time, T_r , is the time between photo detector output intensity changed from 90% to 10% . And fall time, T_f , is the time between photo detector output intensity changed from 10% to 90% .

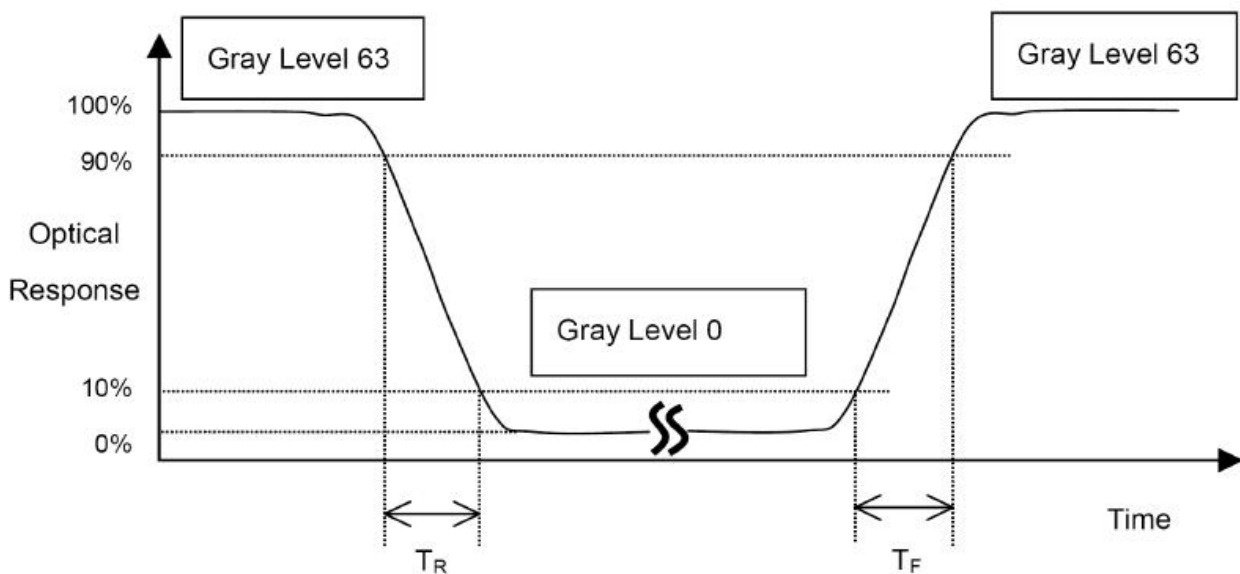

Note 4: Definition of contrast ratio:

The contrast ratio is defined as the following expression.

$$\text{Contrast ratio (CR)} = \frac{\text{Luminance measured when LCD on the "White" state}}{\text{Luminance measured when LCD on the "Black" state}}$$

Note 5: White $V_i = V_{i50} \pm 1.5V$

Black $V_i = V_{i50} \pm 2.0V$

"±" means that the analog input signal swings in phase with VCOM signal.

"±" means that the analog input signal swings out of phase with VCOM signal.

The 100% transmission is defined as the transmission of LCD panel when all the input terminals of module are electrically opened.

Note 6: Definition of color chromaticity (CIE 1931)

Color coordinates measured at the center point of LCD

Note 7: Measured at the center area of the panel when all the input terminals of LCD panel are electrically opened.

$$\text{Note 8 : Uniformity (U)} = \frac{\text{Brightness (min)}}{\text{Brightness (max)}} \times 100\%$$

9. RELIABILITY

No.	Test Item	Test Condition	Remark
1	High Temperature Storage	+80°C± 2°C, 96 hrs	Note
2	Low Temperature Storage	-30°C± 2°C, 96 hrs	Note
3	High Temperature Operation	+70°C± 2°C, 96 hrs	Note
4	Low Temperature Operation	+20°C± 2°C, 96 hrs	Note
5	High Temperature & High Humidity Storage Test	+50°C± 5°C, 90%R.H, 96 hours	Note
6	Temperature Cycle (non operation)	-30°C ← +25°C → +80°C (30mins ← 5mins → 30mins) 10 Cycles	Note
7	Electronic Static Discharge	Air Discharge: 2KV to with 5 times	Discharge for each polarity Mode of Operation: Single Discharge, successive discharge at least 1 sec
		Ambiance: 15°C~35°C, 30%~60%R.H Resistance(Rd): 330Ω ±10% Capacitance(Cs + Cd): 150pF±10%	
8	Vibration (Packaged)	Frequency range: 10Hz ~ 55 Hz Amplitude: 1.5mm Direction of X.Y. Z for 3 Hrs in total	
9	Drop Test (Packaged)	Height: 80cm, Time: 1 1 corner, 3 edged, 6 surfaces	

Note : Recovery Time should be 2~4 hours at room temperature (20±8°C) and humidity (below 60% R.H). No abnormalities in functions and appearance

■ Inspection Standard

Defects are classified as major defects and minor defects according to the degree of defectiveness defined herein.

If the Customer has other agreements with Display Future Ltd for standards, please refer to that agreement.

Inspection Condition

Room Temperature: 25±5°C.

Humidity: 65±5% RH. Illu-

mination: 300 ~ 700 Lux.

Distance: 35±5 cm

Major defect.

Item No	Items to be inspected	Inspection Standard
1	All functional defects	1) No display 2) Display abnormally 3) Short circuit 4) line defect
2	missing	Missing function component
3	Crack	Glass Crack

Minor defect.

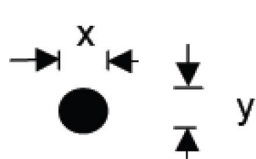
Item No	Items to be inspected	Inspection standard	
1	Spot Defect Including Black spot White spot Pinhole Foreign particle Polarizer dirt	For dark/white spot is defined: $\varphi = (x+y) / 2$ 	
		Size φ (mm)	Size φ (mm)
		$\varphi \leq 0.15$	Ignore
		$0.15 < \varphi \leq 0.30$	3
		$0.30 < \varphi$	Not allowed

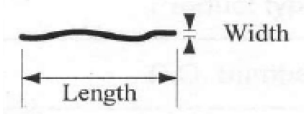
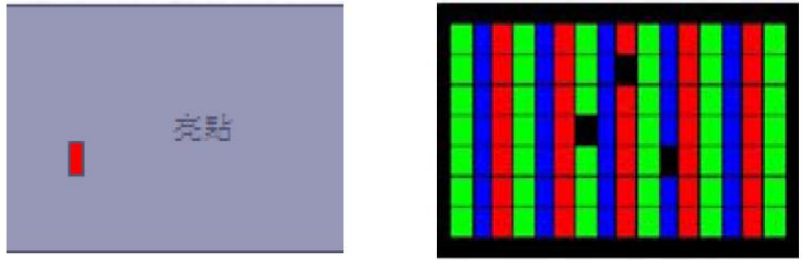
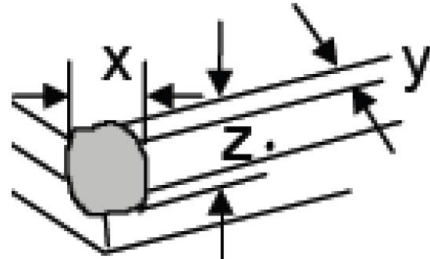
2	Line Defect Including Black line White line Scratch	Define:			
					
		Width(mm)	Length(mm)	Acceptable Quantity	
		$W \leq 0.03$		Ignore	
		$0.03 < W \leq 0.05$	$L \leq 4.0$	3	
	$0.03 < W \leq 0.08$	$L \leq 4.0$	1		
	$0.08 < W$	$L > 4.0$	Not allowed		
3	Polarizer Dent/Bubble	Width(mm) Length(mm)			
		$\phi \leq 0.25$			
		$0.2 < \phi \leq 0.3$			
		$0.3 < \phi \leq 0.5$			
		$0.5 < \phi$	0		
4.	Electrical Dot Defect	Bright and Black dot define:			
					
		Inspection pattern: Full white、 Full black、 Red、 green and blue screens			
		Item	Acceptable Quantity		
			I area	O area	Total
	Black dot defect	1	3	3	
	Bright dot defect	1	1	1	
	Total Dot	2	4	4	
5	Glass defect	1. Corner Fragment:			
					
		Size(mm)	Acceptable Quantity		

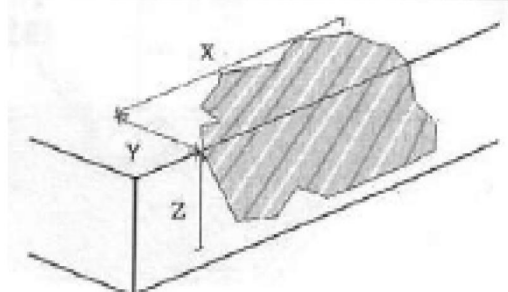
		$X \leq 4.0\text{mm}$ $Y \leq 3.0\text{mm}$ $Z \leq T$	Ignore T: Glass thickness X: Length Y: Width Z: thickness
		2.Side Fragment: 	
		Size(mm)	Acceptable Quantity
		$X \leq 5.0\text{mm}$ $Y \leq 2.0\text{mm}$ $Z \leq T$	Ignore T: Glass thickness X: Length Y: Width $Z \leq T$ Z: thickness

Note:

1. Dot defect is defined as the defective area of the dot area is larger than 50% of the dot area.
2. The distance between two bright dot defects (red, green, blue, and white) should be larger than 15mm.
3. The distance between black dot defects or black and bright dot defects should be more than 5mm apart.
4. The definitions of the inner display area

And outer display area

I: Inner display area

O: Outer display area

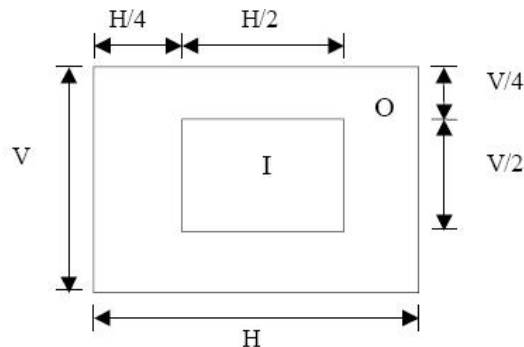

■ PRECAUTIONS FOR USING LCD MODULES

Handing Precautions

(1) The display panel is made of glass and polarizer. As glass is fragile. It tends to become or chipped during handling especially on the edges. Please avoid dropping or jarring. Do not subject it to a mechanical shock by dropping it or impact.

(2) If the display panel is damaged and the liquid crystal substance leaks out, be sure not to get any in your mouth. If the substance contacts your skin or clothes, wash it off using soap and water.

(3) Do not apply excessive force to the display surface or the adjoining areas since this may cause the color tone to vary. Do not touch the display with bare hands. This will stain the display area and degraded insulation between terminals (some cosmetics are determined to the polarizer).

(4) The polarizer covering the display surface of the LCD module is soft and easily scratched. Handle this polarizer carefully. Do not touch, push or rub the exposed polarizers with anything harder than an HB pencil lead (glass, tweezers, etc.). Do not put or attach anything on the display area to avoid leaving marks on. Condensation on the surface and contact with terminals due to cold will damage, stain or dirty the polarizer. After products are tested at low temperature they must be warmed up in a container before coming is contacting with room temperature air.

(5) If the display surface becomes contaminated, breathe on the surface and gently wipe it with a soft dry cloth. If it is heavily contaminated, moisten cloth with one of the following solvents

- Isopropyl alcohol
- Ethyl alcohol

Do not scrub hard to avoid damaging the display surface.

(6) Solvents other than those above-mentioned may damage the polarizer. Especially, do not use the following.

- Water
- Ketone
- Aromatic solvents

Wipe off saliva or water drops immediately, contact with water over a long period of time may cause deformation or color fading. Avoid contacting oil and fats.

(7) Exercise care to minimize corrosion of the electrode. Corrosion of the electrodes is accelerated by water droplets, moisture condensation or a current flow in a high-humidity environment.

(8) Install the LCD Module by using the mounting holes. When mounting the LCD module make sure it is free of twisting, warping and distortion. In particular, do not forcibly pull or bend the I/O cable or the backlight cable.

(9) Do not attempt to disassemble or process the LCD module.

(10) NC terminal should be open. Do not connect anything.

(11) If the logic circuit power is off, do not apply the input signals.

(12) Electro-Static Discharge Control, Since this module uses a CMOS LSI, the same careful attention should be paid to electrostatic discharge as for an ordinary CMOS IC. To prevent destruction of the elements by static electricity, be careful to maintain an optimum work environment.

- Before remove LCM from its packing case or incorporating it into a set, be sure the module and your body have the same electric potential. Be sure to ground the body when handling the LCD modules.

- Tools required for assembling, such as soldering irons, must be properly grounded. make certain the AC power source for the soldering iron does not leak. When using an electric screwdriver to attach LCM, the screwdriver should be of ground potentiality to minimize as much as possible any transmission of electromagnetic waves produced sparks coming from the commutator of the motor.

- To reduce the amount of static electricity generated, do not conduct assembling and other work under dry conditions. To reduce the generation of static electricity be careful that the air in the work is not too dried. A relative humidity of 50%-60% is recommended. As far as possible make the electric potential of your work clothes and that of the work bench the ground potential

- The LCD module is coated with a film to protect the display surface. Exercise care when peeling off this protective film since static electricity may be generated

(13) Since LCM has been assembled and adjusted with a high degree of precision, avoid applying excessive shocks to the module or making any alterations or modifications to it.

- Do not alter, modify or change the shape of the tab on the metal frame.
- Do not make extra holes on the printed circuit board, modify its shape or change the positions of components to be attached.
- Do not damage or modify the pattern writing on the printed circuit board.
- Absolutely do not modify the zebra rubber strip (conductive rubber) or heat seal connector.
- Except for soldering the interface, do not make any alterations or modifications with a soldering iron.
- Do not drop, bend or twist LCM.

Handling precaution for LCM

LCM is easy to be damaged.
Please note below and be careful for handling!

Correct handling:



As above picture, please handle with anti-static gloves around LCM edges.

Incorrect handling:

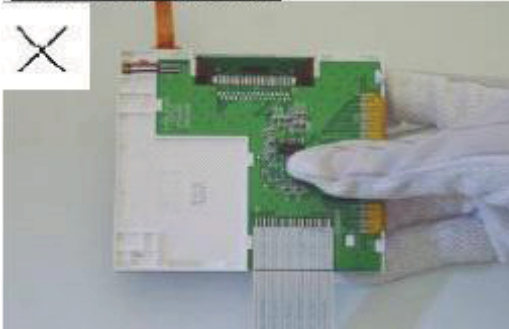

Please don't touch IC directly.

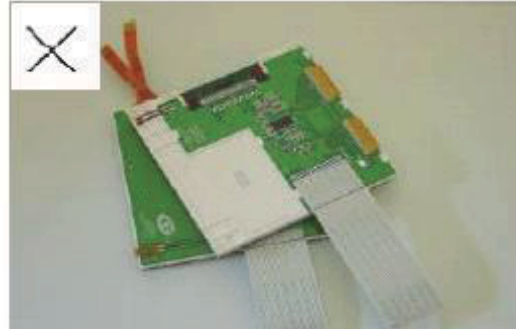

Please don't stack LCM.

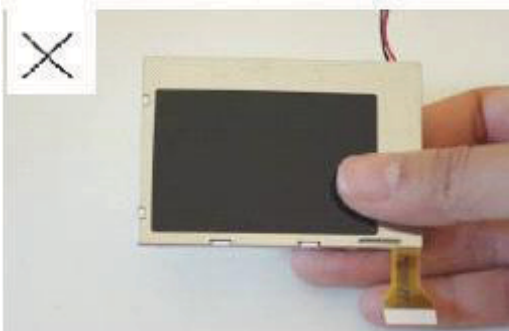

Please don't hold the surface of panel.

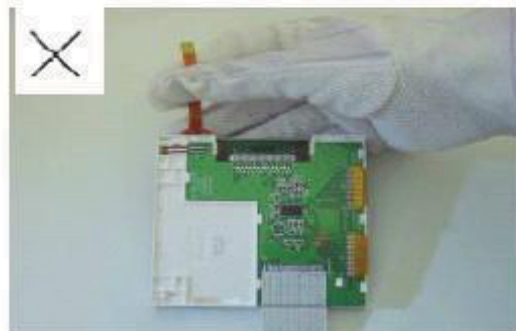

Please don't stretch interface of output, such as FPC cable.

Handling precaution for LCD

LCD is easy to be damaged.
Please note below and be careful for handling!

Correct handling:

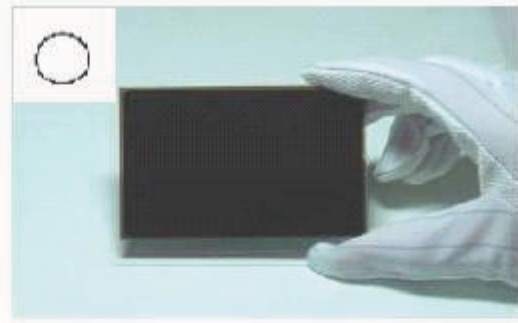
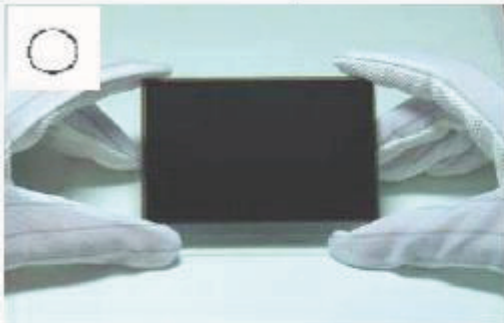

As above photo, please handle with anti-static gloves around LCD edges.

Incorrect handling:

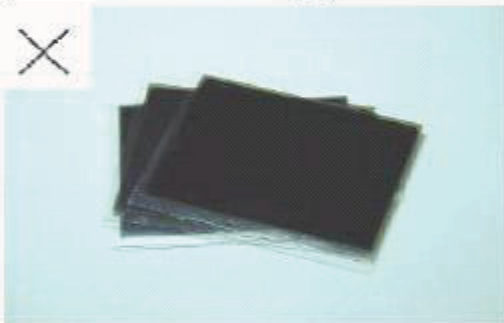

Please don't stack the LCDS.

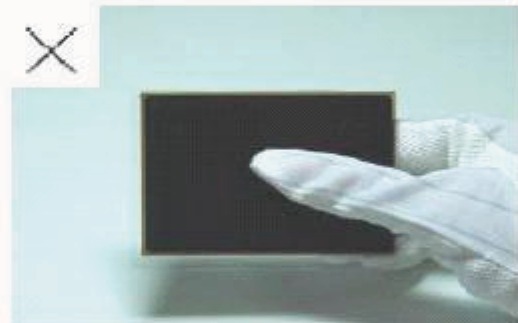

Please don't hold the surface of LCD.

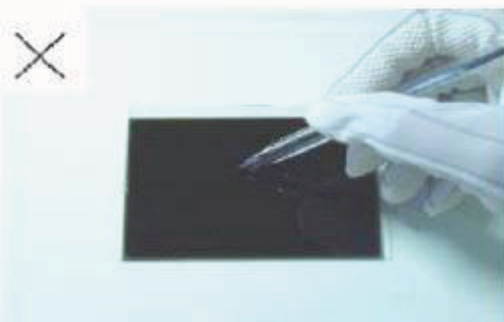

Please don't operate with sharp stick such as pens.

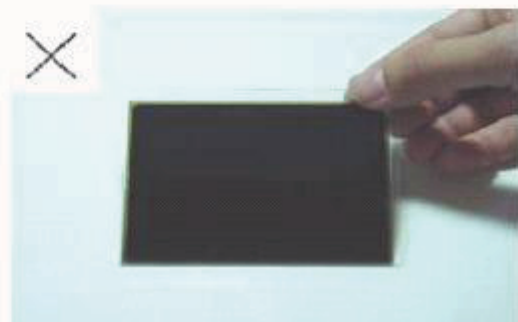

Please don't touch ITO glass without anti-static gloves.

Storage Precautions

When storing the LCD modules, the following precaution is necessary.

- (1) Store them in a sealed polyethylene bag. If properly sealed, there is no need for the dessicant.
- (2) Store them in a dark place. Do not expose to sunlight or fluorescent light, keep the temperature between 0°C and 35°C, and keep the relative humidity between 40%RH and 60%RH.
- (3) The polarizer surface should not come in contact with any other objects. (We advise you to store them in the anti-static electricity container in which they were shipped.

Others

Liquid crystals solidify under low temperature (below the storage temperature range) leading to defective orientation or the generation of air bubbles (black or white). Air bubbles may also be generated if the module is subject to a low temperature.

If the LCD modules have been operating for a long time showing the same display patterns, the display patterns may remain on the screen as ghost images and a slight contrast irregularity may also appear. A normal operating status can be regained by suspending use for some time. It should be noted that this phenomenon does not adversely affect performance reliability.

To minimize the performance degradation of the LCD modules resulting from destruction caused by static electricity etc., exercise care to avoid holding the following sections when handling the modules.

- Exposed area of the printed circuit board.
- Terminal electrode sections.

USING LCD MODULES

Installing LCD Modules

The hole in the printed circuit board is used to fix LCM as shown in the picture below. Attend to the following items when installing the LCM.

- (1) Cover the surface with a transparent protective plate to protect the polarizer and LC cell.

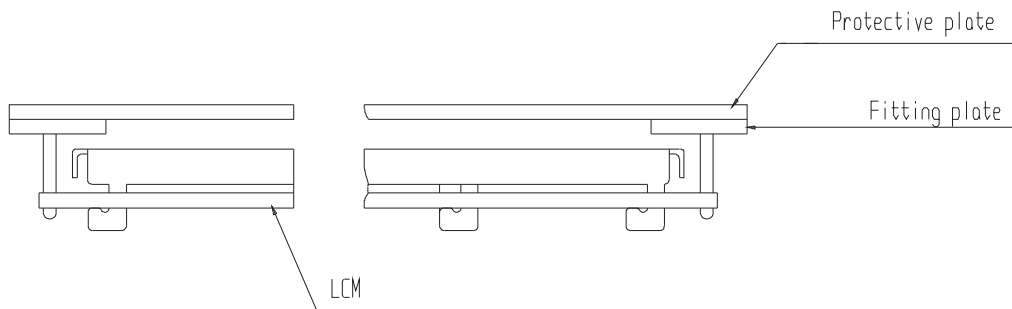

- (2) When assembling the LCM into other equipment, the spacer to the bit between the LCM and the fitting plate should have enough height to avoid causing stress to the module surface, refer to the individual specifications for measurements. The measurement tolerance should be ± 0.1 mm.

Precaution for assemble the module with BTB connector:

Please note the position of the male and female connector position, don't assemble or assemble like the method which the following picture shows

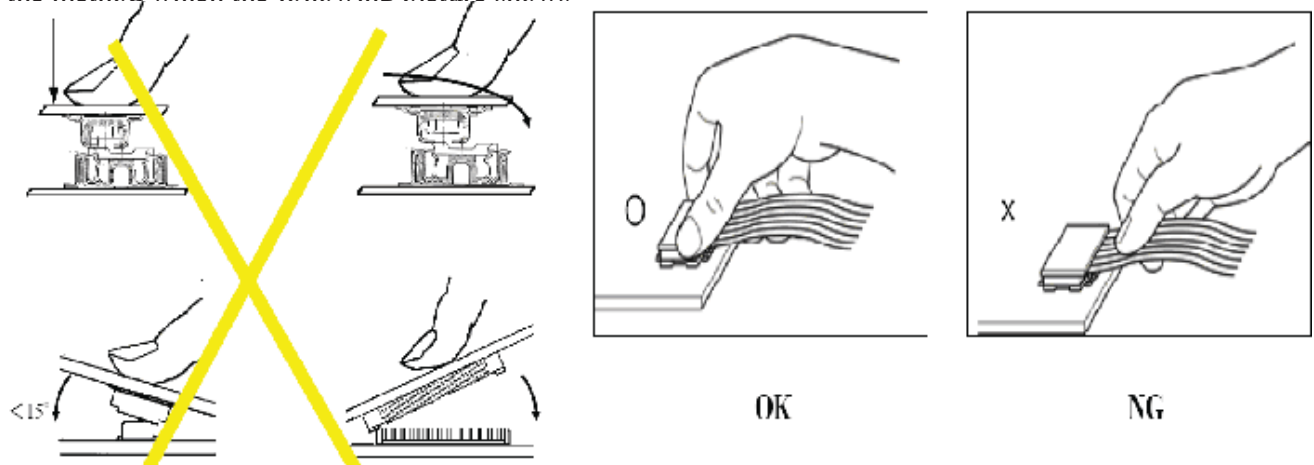

Precaution for soldering to the LCM

	Hand soldering	Machine drag soldering	Machine press soldering
No ROHS product	290°C ~350°C. Time : 3-5S.	330°C ~350°C. Speed : 4-8 mm/s.	300°C ~330°C. Time : 3-6S. Press: 0.8~1.2Mpa
ROHS product	340°C ~370°C. Time : 3-5S.	350°C ~370°C. Time : 4-8 mm/s.	330°C ~360°C. Time : 3-6S. Press: 0.8~1.2Mpa

(1) If soldering flux is used, be sure to remove any remaining flux after finishing to soldering operation. (This does not apply in the case of a non-halogen type of flux.) It is recommended that you protect the LCD surface with a cover during soldering to prevent any damage due to flux spatters.

(2) When soldering the electroluminescent panel and PC board, the panel and board should not be detached more than three times. This maximum number is determined by the temperature and time conditions mentioned above, though there may be some variance depending on the temperature of the soldering iron.

(3) When remove the electroluminescent panel from the PC board, be sure the solder has completely melted, the soldered pad on the PC board could be damaged.

Precautions for Operation

(1) Viewing angle varies with the change of liquid crystal driving voltage (VLCD). Adjust VLCD to show the best contrast.

(2) It is an indispensable condition to drive LCD's within the specified voltage limit since the higher voltage then the limit cause the shorter LCD life. An electrochemical reaction due to direct current causes LCD's undesirable deterioration, so that the use of direct current drive should be avoided.

(3) Response time will be extremely delayed at lower temperature than the operating temperature range and on the other hand at higher temperature LCD's show dark color in them. However those phenomena do not mean malfunction or out of order with LCD's, Which will come back in the specified operating temperature.

(4) If the display area is pushed hard during operation, the display will become abnormal. However, it will return to normal if it is turned off and then back on.

(5) A slight dew depositing on terminals is a cause for electro-chemical reaction resulting in terminal open circuit. Usage under the maximum operating temperature,50%RH or less is required.

(6) Input each signal after the positive/negative voltage becomes stable.

(7) Please keep the temperature within specified range for use and storage. Polarization degradation, bubble generation or polarizer peel-off may occur with high temperature and high humidity.

Safety

(1) It is recommended to crush damaged or unnecessary LCDs into pieces and wash them off with solvents such as acetone and ethanol, which should later be burned.

(2) If any liquid leaks out of a damaged glass cell and comes in contact with the hands, wash off thoroughly with soap and water.

Safety

- (1) It is recommended to crush damaged or unnecessary LCDs into pieces and wash them off with solvents such as acetone and ethanol, which should later be burned.
- (2) If any liquid leaks out of a damaged glass cell and comes in contact with the hands, wash off thoroughly with soap and water.

Limited Warranty

Unless agreed otherwise between Display Future Ltd and customer, Display Future will replace or repair any of its LCD modules which are found to be functionally defective when inspected in accordance with LCD acceptance standards (copies available upon request) for a period of one year from date of production. Cosmetic/visual defects must be returned within 90 days of the shipment. Confirmation of such date shall be based on data code on the product.

The warranty liability of Display Future limited to repair and/or replacement on the terms set forth above. Display Future will not be responsible for any subsequent or consequential events.

Return LCM under warranty

No warranty can be granted if the precautions stated above have been disregarded. The typical examples of violations are :

- Broken LCD glass.
- PCB eyelet is damaged or modified.
- PCB conductors damaged.
- Circuit modified in any way, including addition of components.
- PCB tampered with by grinding, engraving or painting varnish.
- Soldering to or modifying the bezel in any manner.

Module repairs will be invoiced to the customer upon mutual agreement. Modules must be returned with sufficient description of the failures or defects. Any connectors or cable installed by the customer must be removed completely without damaging the PCB eyelet, conductors and terminals.

■ PRIOR CONSULT MATTER

- 1.①For Display Future standard products, we keep the right to change material and processes for improving the product, without notice to our customers.
②For OEM products, if any change is needed, which may affect the product property, we will consult with our customer in advance.
2. If you have special requirement about reliability condition, please let us know before you start the test on our samples.