



FORMIKE ELECTRONIC CO.,LTD

PRDUCT SPECIFICATON

Color STN LCD MODULE

MODEL : KWH0145DN05-076B VER:0.0

【 】 Preliminary Specification

【 ◆】 Finally Specification

Prepared By :

FORMIKE ELECTRONIC CO.,LTD

Address : A909,97 Huaying Building,Nanshang Road,Nanshan District, Shenzhen, China.518054

TEL:(86) 755 88306921,88306931 FAX:(86) 755 88304615

Http:// www.wandisplay.com

- This specification is subject to change withouth notice.Please contact FORMIKE or it's representative before designing your product based on this specification.

Issued Date : Sep-29-2007

Design Specification for Approval

Customer			
Product Model	KWH0145DN05-076B	REV.NO.	V0.0
Designed by	CHENYIUYI	Checked by	
Approved by		Date	2007.09.29

Final Approval by Customer

Date:

Approved	Checked	Department

The specification of "TBD" should refer to the measured value of sample . If there is difference between the design specification and measured value, we naturally shall negotiate and agree to solution with customer. Formike Electronic Co.,Ltd reserve the right to make corrections, modifications, enhancements, improvements, and other changes to its products and services at any time and to discontinue any product or service without notice. Customers should obtain the latest relevant information before placing orders and should verify that such information is current and complete. All products are sold subject to Formike s terms and conditions of sale supplied at the time of order acknowledgment.

Contents

No.	Item	Page
1	Cover	1/23
2	Approve Sheet	2/23
3	Contents	3/23
4	Revision History	4/23
5	Scope	5/23
6	Normative Reference	5/23
7	Definitions	5/23
8	Technology Specifications	6/23
9	Circuit Block Diagram	10/23
10	Scheduling	11/23
11	Reliability Test Condition And Methods	13/23
12	Inspect Standard	13/23
13	Handing Precautions	20/23
14	Precaution For Use	22/23
15	Dimensional Outline	23/23

1. Scope

This specification applies to the color STN LCD module which is designed and manufactured by Formike Electronic Co.,Ltd.

It is capable of using 8bits data bus and operating with 8080-series MPU. Also 65k , 262K、 16M colors mode can be selected by setting instruction.

2. Normative Reference

GB/T4619-1996 《 Liquid Crystal Display Test Method》

GB/T2424 《Basic environmental Testing Procedures for Electric and Electronic Products.》

GB/T2423 《Basic Testing Procedures for Electric and Electronic Products》

IEC61747-1 SIXTH PART

GB2828 2829-87 《National Standard of PRC》

3. Definitions

3.1 Definition of Response Time T_r , T_d

T_r : The time required which the brightness of segment becomes 90% from 10% when waveform is switched to selected one from non-selected one.

($f_r=80\text{Hz}$, $\theta=0^\circ$ $\theta=90^\circ$ at 25)

T_d : The time required which the brightness of segment becomes 10% from 90% when waveform is switched to non-selected one from selected one.

($f_r=80\text{Hz}$, $\theta=0^\circ$ $\theta=90^\circ$ at 25)

3.2 Definition of Contrast Ratio Cr

$$Cr=A/B$$

A: Segments brightness in case of selected waveform

B: Segments brightness in case of non-selected waveform

3.3 Definition of Angle and Viewing Range

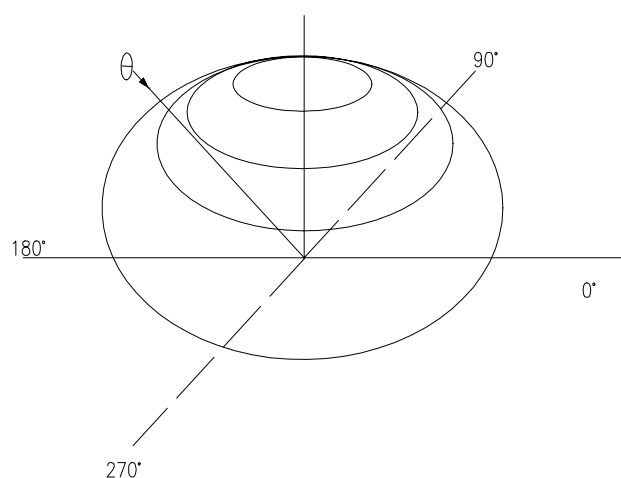
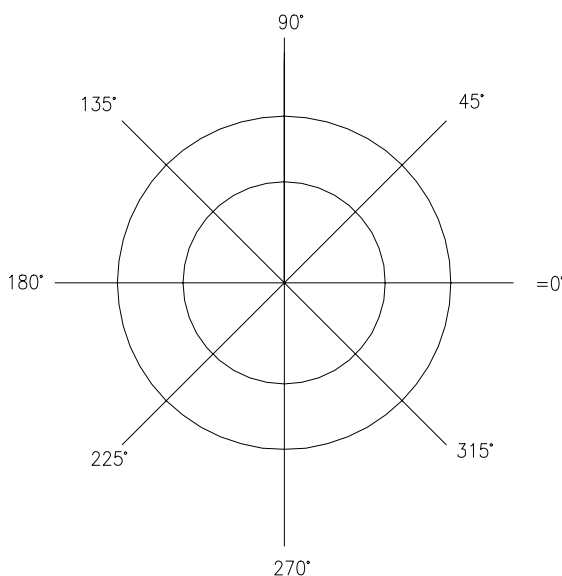

Angular Graph: Constrast Ratio

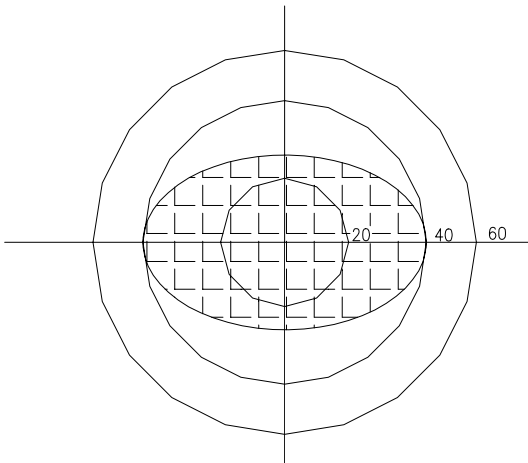

	=0 °	=0 °	Cr
Right	50 °		2
Left	50 °		
Front	40 °		
Back	40 °		

4. Technology Specifications

4.1 Feature

Item	Standard Value
Display Type	128(W) × RGB × 128(H)
LCD Type	CSTN Negative Transmissive
Drive Mothod	1/128 Duty 1/12 Bias
Screen Size	1.45 (Diagonal)
Viewing Direction	6 o'clock
Color configuration	R.G.B
Backlight type	White LED B/L
Interface	8-bit data bus
Drive IC	ST7637 (Support 65K)

4.2 Mechanical Specifications

Item	Specifications	Unit
Dimensional Outline	33.30(W) ×51.00(H)×2. 50 (T)	mm
Number Of Dots	128(W) ×128(H)	Dots
Viewing Area	28.10(W) ×28.20(H)	mm
Active Area	25.49 (W) ×26.48 (H)	mm
Pixel Pitch	0.0664(W) ×0.207(H)	mm
Dots Size	0.0564(W) ×0.197(H)	mm

4.3 Absolute Max. Rating

Item	Symbol	Min	Max	Unit	Note
Supply voltage	Vdd	-0.3	3.0	V	
Input Voltage	Vin	-0.3	Vdd+0.5	V	
Operating Temperature	Top	-20	70		
Storage Temperature	Tst	-30	80		
Humidity	HD-	20	90	%RH	

4.4 Optical Characteristics

Item	Symbol	Condition	Temp	Min	Typ	Max	Units
LCD driving voltage	Vlcd	= =0	25	---	14.7	---	V
Response Time	Rise Time (Tr)	= =0	0	---	---	---	msec
	Decay Time (Td)						
	Rise Time (Tr)		25	---	250	---	
	Decay Time (Td)						
	Rise Time (Tr)		50	---	---	---	
	Decay Time (Td)						
Contrast Ratio	Cr	= =0	25	---	30	---	---

Item		Symbol	Temp	Condition	Min	Typ	Max	Unit	Note
Color Of CIE Coordinate	White	x	25	=0 ° =0 °	0.22	0.27	0.32		
		y			0.23	0.28	0.33		
	Red	x			0.44	0.49	0.54		
		y			0.24	0.29	0.34		
	Green	x			0.24	0.29	0.34		
		y			0.37	0.50	0.57		
	Blue	x			0.12	0.17	0.22		
		y			0.10	0.15	0.20		

4.5 Electrical Characteristics

4.5.1 Electrical Characteristics (VSS=0V,Vdd=2.7-3.0V ,Ta=-20 to 70°C)

Item		Symbol	Condition	Min	Typ	Max	Unit	Note
Supply Voltage (Logic)		Vdd	-	2.7	2.8	3.0	V	
Input Voltage	"H" level	VIH	VDD	0.7VDD	-	VDD	V	
	"L" level	VIL	VSS	VSS	-	0.3VDD		
Output Voltage	"H" level	VOH	0.8VDD	0.8VDD	-	VDD	V	
	"L" level	VOL	VSS	VSS	-	0.2VDD		

4.5.2 Interface Pin Connections

NO.	Symbol	Definition
1	VDD	Power supply input for drive IC
2	GND	Ground
3-4	NC	No connection
5	CSB	Chip select pin,active "L"
6	CD	Date and control register select input H: D0 to D7 are display date L: D0 to D7 are control date
7	RD	Read signal input, active "L"
8	WR	Write signal input, active "L"
9	RESB	Reset signal input pin, active "L"
10	DB0	8-bit bi-directional data bus
11	NC	No connection
12	DB1	8-bit bi-directional data bus
13	NC	No connection
14	DB2	8-bit bi-directional data bus
15	NC	No connection
16	DB3	8-bit bi-directional data bus
17	NC	No connection
18	DB4	8-bit bi-directional data bus
19	NC	No connection
20	DB5	8-bit bi-directional data bus
21	NC	No connection
22	DB6	8-bit bi-directional data bus
23	NC	No connection
24	DB7	8-bit bi-directional data bus
25	NC	No connection
26	LED-	Power supply cathode input for backlight
27	LED+	Power supply anode input for backlight

5.Circuit Block Diagram

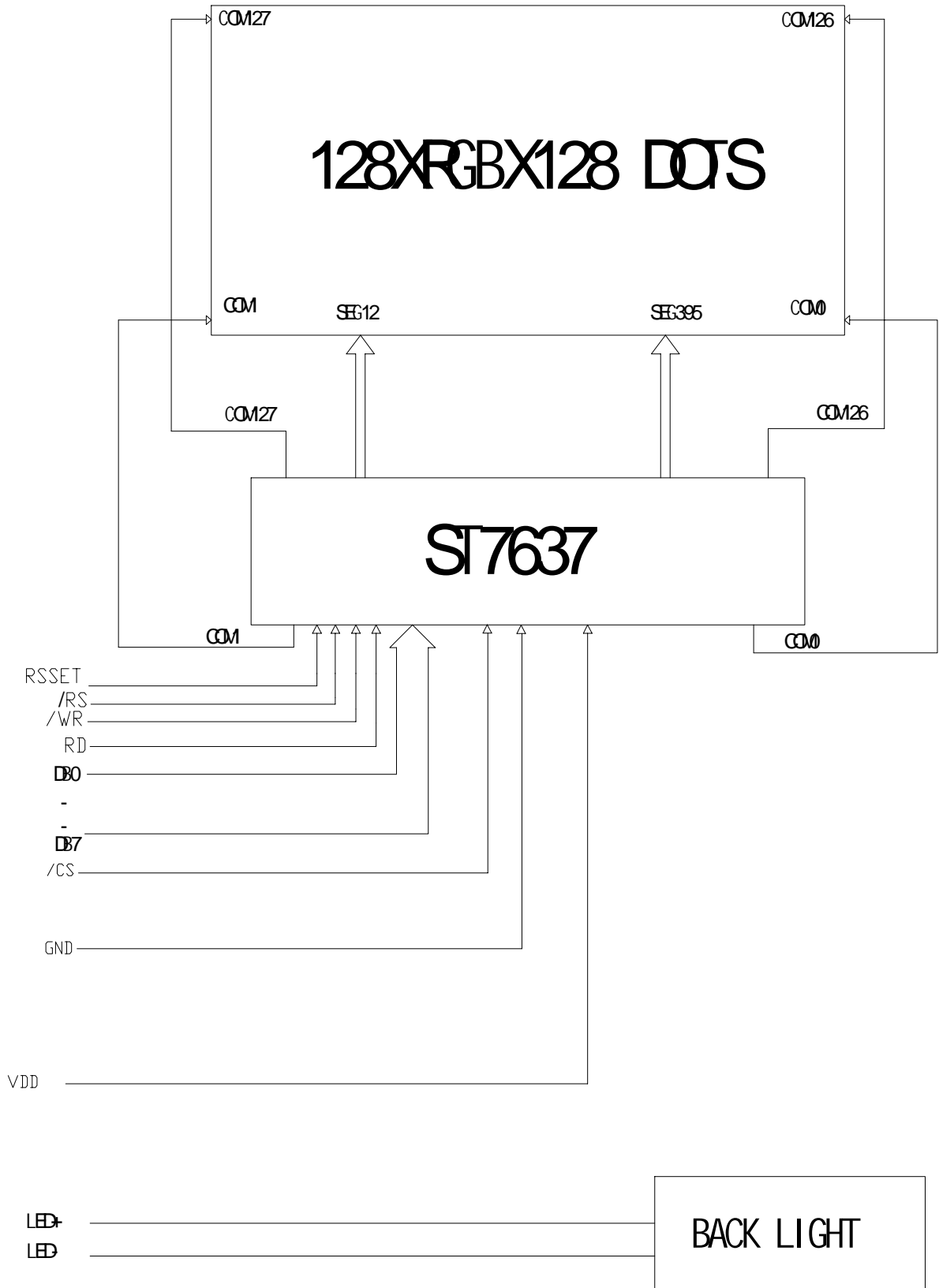

6. Scheduling

ST7637 Scheduling

- Read/write Characteristics (8080-series Parallel mode)

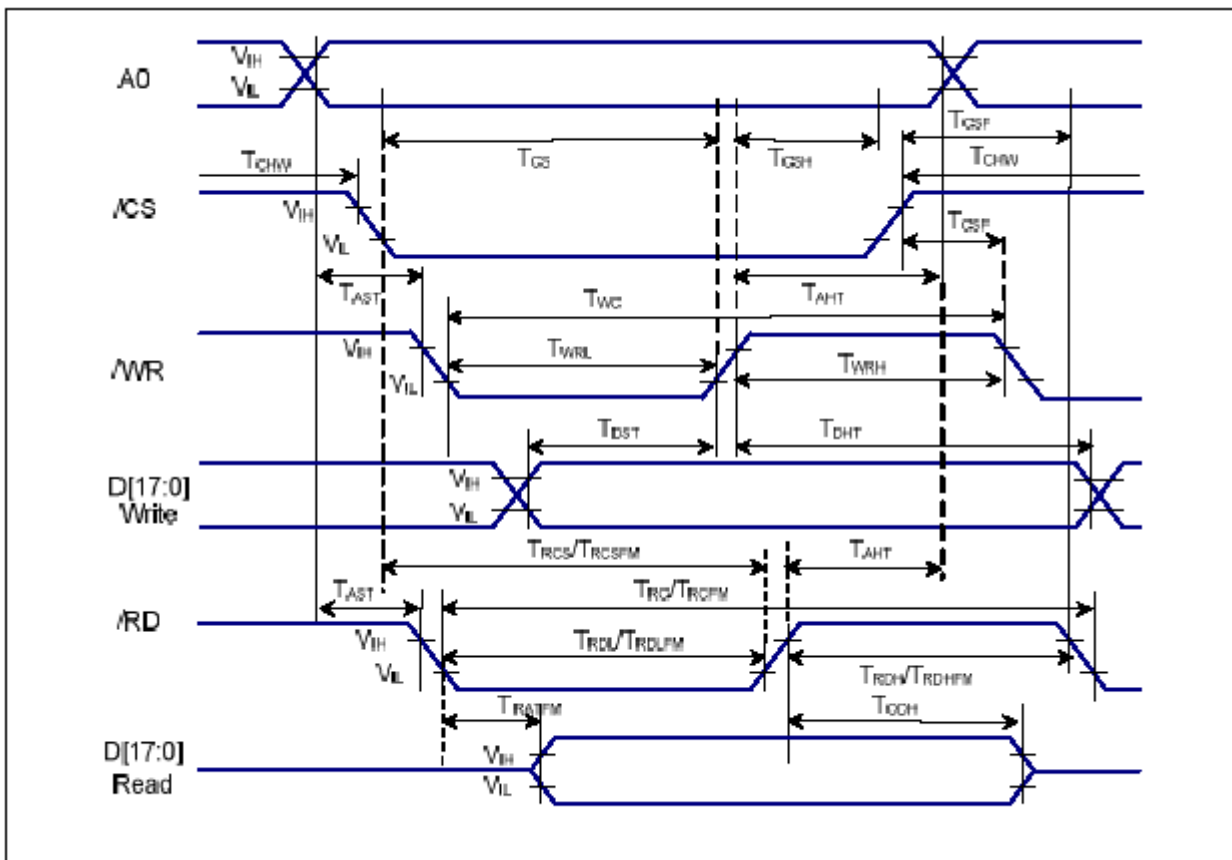

(VSS=0V, VDDI=1.65V to 2.9V, VDDA=2.3V to 3.3V, Ta = -30 to 70° C)

Signal	Symbol	Parameter	MIN	MAX	Unit	Description
A0	T _{AST}	Address setup time	10	-	ns	-
	T _{AHT}	Address hold time (Write/Read)	10	-	ns	-
/CS	T _{CHW}	Chip select "H" pulse width	0	-	ns	-
	T _{CS}	Chip select setup time (Write)	35	-	ns	-
	T _{RCS}	Chip select setup time (Read ID)	45	-	ns	-
	T _{RCSFM}	Chip select setup time (Read FM)	355	-	ns	-
	T _{CSF}	Chip select wait time (Write/Read)	10	-	ns	-
WR	T _{WC}	Write cycle	100	-	ns	-
	T _{WRH}	Control pulse "H" duration	35	-	ns	-
	T _{WRL}	Control pulse "L" duration	35	-	ns	-
RD (ID)	T _{RC}	Read cycle (ID)	100	-	ns	When read ID data
	T _{RDH}	Control pulse "H" duration (ID)	90	-	ns	
	T _{RDL}	Control pulse "L" duration (ID)	45	-	ns	
RD (FM)	T _{RCFM}	Read cycle (FM)	450	-	ns	When read from frame memory
	T _{RDHF}	Control pulse "H" duration (FM)	90	-	ns	
	T _{RDLFM}	Control pulse "L" duration (FM)	355	-	ns	
D[17:0]	T _{DST}	Data setup time	10	-	ns	For maximum CL=30pF For minimum CL=8pF
	T _{DHT}	Data hold time	10	-	ns	
	T _{RAT}	Read access time (ID)	-	40	ns	
	T _{RATFM}	Read access time (FM)	-	340	ns	
	T _{ODT}	Output disable time	20	80	ns	

Reset Input Timing

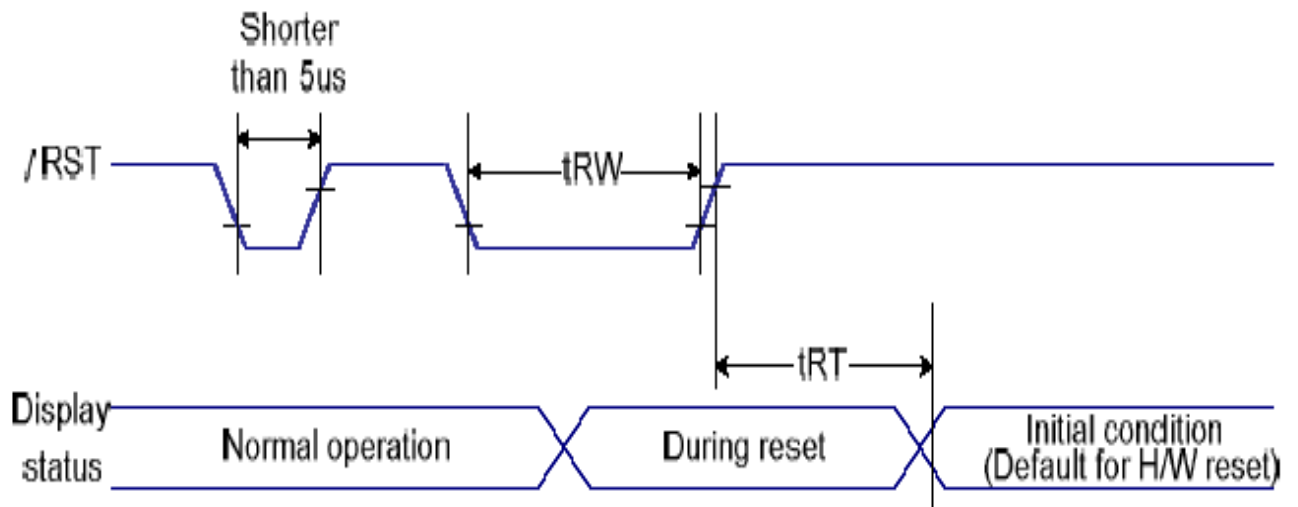

Item	Signal	Symbol	Condition	Rating		Units
				Min	Max	
Reset " L " pulse width	/RST	t _{RW}		10	---	us
Reset time		t _{RT}		---	5	ms
				---	120	ms

7. Reliability Test Conditions And Methods

NO	Check Item	Test condition	Criteria	Defects	Remarks
1	Electricity aging (COG modules)	With normal testing procedures run 24H.	No adverse electrical properties, qualified	MA.	
2	High temperature and high humidity storage	60 ,80%RH,48H	No abnormal appearance, qualified.	MA.	
3	Packaging intensity	Fall	No products or components without damage, qualified.	MA.	
		Static pressure			
4	High Temperature operating	70 ± 2 48H	No adverse electrical properties, qualified	MA.	
	Low Temperature operating	-20 ± 2 48H			
5	High temperature and high humidity operation	50 90% RH,48H	No adverse electrical properties, qualified	MA.	
6	Temperature Cycle	<p>60 ,80%RH,48H Endurance test applying the low and high temperature cycle</p> <p>-20 ←→ 25 ←→ 70 ←→ 25</p> <p>30min 5min 30min 5min</p> <p>1 cycle 10 cycles</p>	No abnormal appearance, qualified.	MA.	

8. Inspection standard

8.1 Summary

8.1.1 Scope of application :

The standards apply to COG category module products factory inspection (this also applies to the production process when measured by the corresponding inspection of the criteria for judgment).

8.1.2 Criterion :

GB/T2828.1-2003 Scottish economy Sampling inspection procedures and sampling table.

8.1.3 Instruments :

The corresponding model module tester, a multimeter, vernier calipers.

8.1.4 Test application :

If this inspection standards and user standards, product specifications, samples confirmation, the confirmation, the design data, the standards

8.2 Inspection requirements

8.2.1 Examination preparation product specifications, drawings, module factory inspection standards, inspection recite the content and if necessary confirmation.

8.2.2 Inspection at the beginning of sets of hands onto fingers, wrist or associated anti-static gloves, confirmation test using the instrumentation and measurement devices is going to use normal state.

8.2.3 Inspections, in strict accordance with the operating conditions, operational guidance on operation and conscientiously make records.

8.2.4 Inspections, equipment or products anomalies, should terminate inspection, leading to the related report.

8.2.5 During the inspections, found a high percentage of poor or reliability of the bad, it is timely to report to the relevant leadership.

8.2.6 After the inspection, used equipment, apparatus, instruments and measurement equipment, wiped it clean, back into custody place to facilitate the use of the next-time anomaly.

8.2.7 Module components or raw materials, such as LCD, backlight, FPC, IC, silica, ACF qualities and technical parameters has been found in the exceptional standard test into the rear qualified for the production of modules, the modules manufactured products not tested again for the detailed components itself for the quality test we should focus on the modules of the overall appearance, function and reliability test.

8.2.8 Under the inspection records to complete inspection reports, quality certification issued on time, and relevant departments served.

8.3 Test content

8.3.1 Front the product leaves the factory, as required sampling to determine the number of random sampling to.

8.3.2 To confirm acceptance of the grant installment, names, specifications, models, is the number line, without objection, as required, after being checked.

8.3.3 Visual inspection; Reliability Testing; Check the packaging.

Note : For standard users special requirements, then reference <<Product specifications>> or <<Confirmation sample>> the request.

8.3.4 Shows the breakdown

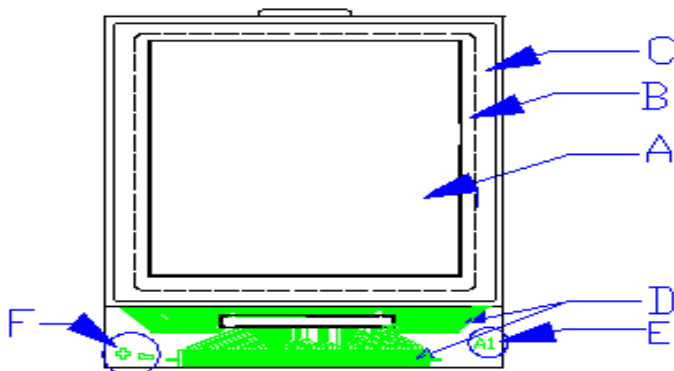

A : active area (A.A) ; B : visible area (V.A) ; C : non-visible area ; D : electrode; E : special marker; F : right-S;

8.4 Sampling

- 8.4.1 Stack the composition: the same model, the same design, the same material, the same manufacturing process in the same cycle of a product or several production constitute approved.
- 8.4.2 Inspection levels: normal production circumstances, Inspection level II (except for dimensions).
- 8.4.3 Sample program:
Normal inspection, a sample.
- 8.4.4 Unqualified installment returned to the workshop after reviewed again after passing the submission of a sample test, and the relevant records marked "BACK TO CHECK" indication.

8.5 Detailed examinations



- 8.5.1 Heavy bug: can be caused failure or significantly reduce the expected performance of product defects.
- 8.5.2 Light bug: not significantly reduce the expected performance deficiencies;
Deviated from the standard but only slightly affected the effective use of products or operating deficiencies.

8.6 Checks and award level

8.6.1 Visual inspection

NO	ITEM	Content	Standard	Method	AQL
1	Model confirmed	With Model	An unusual mixed model, not allowed	Compared with the sample (visual or sounding)	0.65

2	Polaroid	bleb	V.A				Open backlight or visual observation, Benchmark testing	1.5						
			P3 standard		P3 standard									
			size	Allow a few	size	Allow a few								
			0.20	ignore	0.20	ignore								
			0.20 <	2	0.20 <	1								
			0.30		0.30									
			0.30 <	1	>	0								
			0.50		0.30									
		>	0											
				Note 1 : Φ for the bleb diameter; Note 2 : CSTN products even in the films visual bleb, but if black film excluding the region, is qualified goods.										
	Protective film	1 . Protective film or falling over sideways area of LCD 1/3 be allowed 2. Polaroid protective film off, not allowed				Visual								
	Partial affixed	Polaroid edges can not exceed the LCD glass as a fringe.				Visual								
	Scratch	Check exterior light 6.1 3 --- LCD boxes linear defects				Open backlight or visual observation, Benchmark testing								
	Injured	Check exterior light 6.1 3 --- LCD boxes Point defects.												
	Wrinkles	The naked eye can clearly distinguish allowed				Visual								
	Cock	Polaroid edge cock (unglued), not allowed.				Visual								
	Water bellows	Limits of reference samples.				Visual								
	Surface dirt	Surface dirt alcohol cloth to clean the surface dirt is prinkled gently, as if to remove qualified, wiping not to be ineligible.				Visual								
3	LCD	Rainbow (box uneven thickness)	Rainbow emphasis on "restrictions" for failure.				Polarizing inspection	0.65						
		Point defects boxes	 $= (X + Y) / 2, \text{ unit(mm)}$ <table border="1"> <tr> <td>size</td> <td>Allow a few</td> </tr> <tr> <td>0.15</td> <td>ignore</td> </tr> <tr> <td>0.15 <</td> <td>3</td> </tr> <tr> <td>0.20</td> <td></td> </tr> <tr> <td>> 0.2</td> <td>0</td> </tr> </table>						size	Allow a few	0.15	ignore	0.15 <	3
size	Allow a few													
0.15	ignore													
0.15 <	3													
0.20														
> 0.2	0													

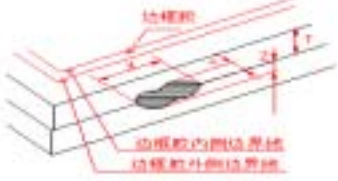
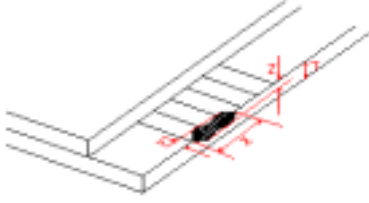
	<p>Boxes linear defects</p>	 <table border="1" data-bbox="443 347 1093 658"> <thead> <tr> <th>Length L</th> <th>Width W</th> <th>Allow a few</th> </tr> </thead> <tbody> <tr> <td>except</td> <td>0.015</td> <td>ignore</td> </tr> <tr> <td>3.0</td> <td rowspan="2">0.015 < W 0.025</td> <td>2</td> </tr> <tr> <td>2.0</td> <td>1</td> </tr> <tr> <td>1.0</td> <td>0.025 < W 0.05</td> <td>1</td> </tr> <tr> <td>except</td> <td>W > 0.05</td> <td>According to determine round</td> </tr> </tbody> </table>	Length L	Width W	Allow a few	except	0.015	ignore	3.0	0.015 < W 0.025	2	2.0	1	1.0	0.025 < W 0.05	1	except	W > 0.05	According to determine round	<p>Polarizing inspection, Benchmark testing</p>	
Length L	Width W	Allow a few																			
except	0.015	ignore																			
3.0	0.015 < W 0.025	2																			
2.0		1																			
1.0	0.025 < W 0.05	1																			
except	W > 0.05	According to determine round																			
	<p>Dimensions</p>	<p>LCD design drawings and not allowed.</p>	<p>Vernier calipers</p>																		
	<p>glass cracks</p>	 <p>It extends to the glass inside the rift trend fail</p>	<p>Light -visual</p>																		
	<p>From top to bottom of the glass breakage</p>	 <div style="border: 1px solid black; padding: 5px; margin: 5px 0;"> <p>Y Not more than plastic frame lateral boundary line X 7.0mm , check out</p> </div> <p>Note : T : monolithic glass thickness; X / Y / Z : Damage length / width / thickness</p>	<p>Caliper</p>	<p>0.65</p>																	
	<p>Broken glass Edge</p>	 <div style="border: 1px solid black; padding: 5px; margin: 5px 0;"> <p>A . Z T, and Y 0.3mm, X except , allowing B . Z T, and 0.3mm < Y 0.5mm, X 7.0mm , allowing</p> </div> <div style="border: 1px solid black; padding: 5px; margin: 5px 0;"> <p>A . Z T, and Y 0.3mm, X except , allowing B . Z T, and 0.3mm < Y 0.5mm, X 3.0mm , allowing</p> </div> <p>Note : T : monolithic glass thickness; X / Y / Z : Damage length / width / thickness.</p>	<p>Caliper</p>																		

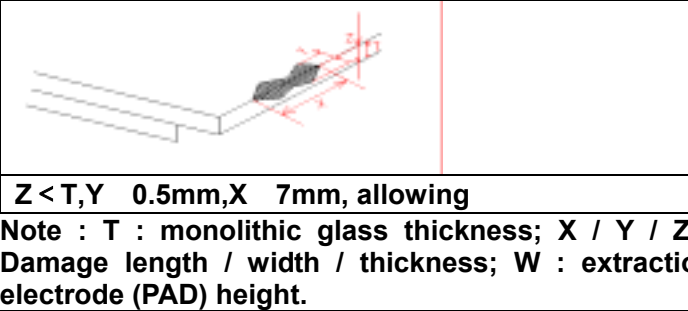
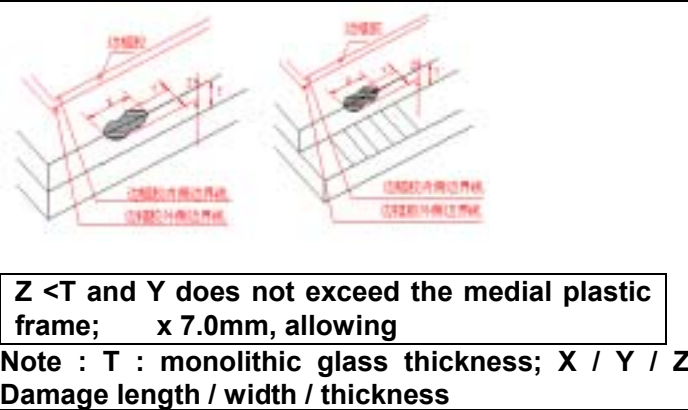
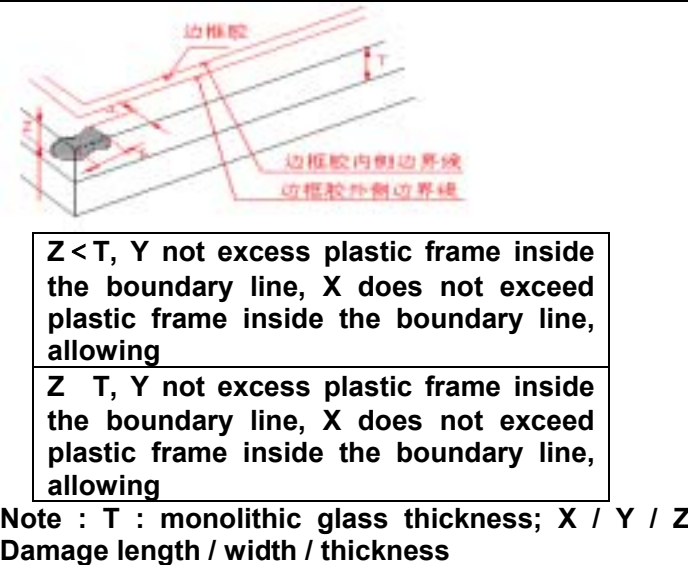
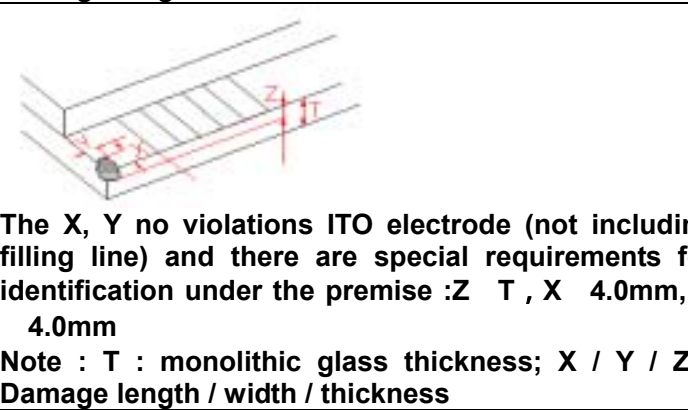
3	LCD	ITO back edge of damage d port	 <p>$Z < T, Y \ 0.5\text{mm}, X \ 7\text{mm}, \text{allowing}$ Note : T : monolithic glass thickness; X / Y / Z : Damage length / width / thickness; W : extraction electrode (PAD) height.</p>	Caliper	0.65
		Other marginal damage	 <p>$Z < T$ and Y does not exceed the medial plastic frame; $x \ 7.0\text{mm}, \text{allowing}$ Note : T : monolithic glass thickness; X / Y / Z : Damage length / width / thickness</p>	Caliper	
		Angle Damage 1	 <p>$Z < T, Y$ not excess plastic frame inside the boundary line, X does not exceed plastic frame inside the boundary line, allowing $Z \ T, Y$ not excess plastic frame inside the boundary line, X does not exceed plastic frame inside the boundary line, allowing Note : T : monolithic glass thickness; X / Y / Z : Damage length / width / thickness</p>	Caliper	
		Angle Damage 2	 <p>The X, Y no violations ITO electrode (not including filling line) and there are special requirements for identification under the premise :Z T, X 4.0mm, Y 4.0mm Note : T : monolithic glass thickness; X / Y / Z : Damage length / width / thickness</p>	Caliper	
4	FPC	FPC bad press	FPC visually evident with the undocking LCD , Unqualified	Visual	0.65

		PFC deviation	FPC deviation , Unqualified	Visual	
		FPC damage	FPC Wrinkle, torn and damaged, FPC damage to the components Unqualified	Visual	
		FPC surface dirt	Obviously the milk attachment , Unqualified	Visual	
5	Back lighting	Crack	In light district are obvious cracks, or from the brink of a regional extension to the light of the trend of the cracks . Unqualified.	Visual	
		Breakin g	The edge or corner breaking display has been exposed. Unqualified	Visual	
6	IC	IC breakin g	IC any degree of damage, Unqualified.	Visual	
7	Silica	Silicone Uniformity	Silicone uneven, as well as some regional non-gel, but in some regions and the impact of too many plastic assembly , Unqualified.	Visual	
8	Other	Bad labeling	Marking and labeling requirements of the position and inconsistent, Unqualified.	Visual	1.5
		Shading belt	There were bubbles and the crimp, tilt beyond Zebra paper edge, and polarizer overlapping folds, such as scratches phenomenon to be ineligible,	Visual	
		Separati on of compon ents	Backlit LCD screen with the undocking, not allowed.	Visual	0.65

8.6.2 Electrical inspection

NO	Check content	Inspection standards	Inspection Methods	AQL
1	Backlight Power	Current voltage reference value "products specifications" or "sample confirmation" indicators, exceeded failure.	Determining current or constant voltage testing. The use of instruments : multimeters, constant current (pressure) source.	0.65
2	Bad Backlight	a. Overall does not shine、 Not missing. b. Luminescence uneven areas (color or brightness) different from the samples or SPEC, not allowed.	Load test Equipment Electricity observation	
3	None Display	not allowed		
4	Perspective wrong	As some blurry or fuzzy part from the opposite direction to see more clearly, and failed.		
5	Low contrast	Show contrast lower, below, " Limited samples" impermissible.		

6	Contrast uneven	The show in different locations, inconsistent contrast, the difference in the " Limited samples " not allowed.				
7	Color difference	"Standard", compared to the naked eye can clearly distinguish , not allowed.				
8	short ,turnoff	not allowed.				
9	Dark Line / dark zoned	not allowed.				
10	Deformation display graphics	Deformation 15% qualified, namely : (A-B) / A, is its admission. Of which : A normal show the width of T, B after deformation of the pen width.				
11	Fixed Point Defects	Refer to 6.1 Visual inspection 3 -- LCD boxes linear defects..				
12	Fixed Point Defects	Refer to 6.1 Visual inspection 3 -- LCD boxes linear defects.				
13	Scintillation black / white dots (block)	 <p>Point / sizes of $\phi = (X + Y) / 2$ is flashing black and white in detection module production process or product tests, the display screen with instant conversion of seamless performance defects.</p> <p>A : rather dark / bright, 0.30, allowing three;</p> <p>B : more lightly, 0.50, allowing three; if necessary, see samples; special circumstances customer prototypes and testing procedures for confirmation</p>			Observation testing procedures	0.65

8.6.3 Packaging Inspection

NO	Check content	Inspection standards	Inspection Methods	AQL
1	Packing method	According <<product specifications>>	Visual	0.65
2	Packet Size	According <<product specifications>>		
3	Packing material	According <<product specifications>>		
4	Printing content	A change color coated shallow, clear, defects such as missing characters not allowed.		
5	Packaging volume	According <<product specifications>>		
6	Complete content	Not neat, inaccurate, inconsistent with the actual , not allowed		
7	Packaging pollution	Packet or packaging materials, which have severe pollution not allowed.		

9 Handling Precautions

9.1 Mounting method

The LCD panel of Formike LCD module consists of two thin glass plates with polarizes which easily be damaged. And since the module is so constructed as to be fixed by utilizing fitting holes in the printed circuit board. Extreme care should be needed when handling the LCD modules.

9.2 Caution of LCD handling and cleaning

When the polarizer has the protection of the film. Use soft cloth with solvent [recommended below] and wipe lightly

- Isopropyl alcohol
- Ethyl alcohol

When the polarizer does not have the protection of the film, Use the texture soft cloth to gently wipe the surface products

Do not wipe the display surface with dry or hard materials that will damage the polarizer surface

Do not use the following solvent:

- Water
- Aromatics

Do not wipe ITO pad area with the dry or hard materials that will damage the ITO patterns

Do not use the following solvent on the pad or prevent it from being contaminated:

- Soldering flux
- Chlorine (Cl) , Sulfur (S)

If goods were sent without being silicon coated on the pad, ITO patterns could be damaged due to the corrosion as time goes on.

If ITO corrosion happens by miss-handling or using some materials such as Chlorine (Cl), Sulfur (S) from customer, Responsibility is on customer.

9.3 Caution against static charge

The LCD module uses C-MOS LSI drivers, so we recommend that you:

Connect any unused input terminal to Vdd or Vss according to the IC specification, do not input any signals before power is turned on, and ground your body, work/assembly areas, assembly equipment to protect against static electricity.

9.4 Caution for operation

- It is an indispensable condition to drive LCD's within the specified voltage limit since the higher voltage than the limit causes the shorter LCD life.
- An electrochemical reaction due to direct current causes LCD's undesirable deterioration, so that the use of direct current drive should be avoided.

- Response time will be extremely delayed at lower temperature and on the other hand LCD's dark color performance at higher temperature. However those phenomena do not mean malfunction 's LCD low-grade performance , which will come back in the specified operation temperature.
- If the display area is pushed hard during operation, some font will be abnormally displayed but it resumes normal condition after turning off once.
- A slight dew depositing on terminals is a cause for electro-chemical reaction resulting in terminal open circuit.

Usage under the maximum operating temperature, 50%Rh or less is required.

9.6 Storage

In the case of storing for a long period of time for instance, for years for the purpose or replacement use, the following ways are recommended.

- Storage in a polyethylene bag with the opening sealed so as not to enter fresh air outside in it . And with no desiccant.
- Placing in a dark place where neither exposure to direct sunlight nor light's keeping the storage temperature range.
- Avoid scratching the surface products.

[Recommended for preservation in the original packaging products]

9.7 Safety

- If a product by the impact or by other factors impact crusher, emergency circumstances recommend the use of acetone or alcohol swabs to clean-out LCD
- When any liquid leaked out of a damaged glass cell comes in contact with your hands, please wash it off well with soap and water

10 . Precaution for use

10.1 A limit sample should be provided by the both parties on an occasion when the both parties agreed its necessity. Judgment by a limit sample shall take effect after the limit sample has been established and confirmed by the both parties.

10.2 On the following occasions, the handing of problem should be decided through discussion and agreement between responsible of the both parties.

- When a question is arisen in this specification
- When a new problem is arisen which is not specified in this specifications
- When an inspection specifications change or operating condition change in customer is reported to DF , and some problem is arisen in this specification due to the change
- When a new problem is arisen at the customer's operating set for sample evaluation in the customer site.

11. Dimensional Outline

